

# UC12

Ultrasonic sensor

**SICK**  
Sensor Intelligence.



## Described product

UC12

## Manufacturer

SICK AG  
Erwin-Sick-Str. 1  
79183 Waldkirch  
Germany

## Legal information

This work is protected by copyright. Any rights derived from the copyright shall be reserved for SICK AG. Reproduction of this document or parts of this document is only permissible within the limits of the legal determination of Copyright Law. Any modification, abridgment or translation of this document is prohibited without the express written permission of SICK AG.

The trademarks stated in this document are the property of their respective owner.

© SICK AG. All rights reserved.

## Original document

This document is an original document of SICK AG.

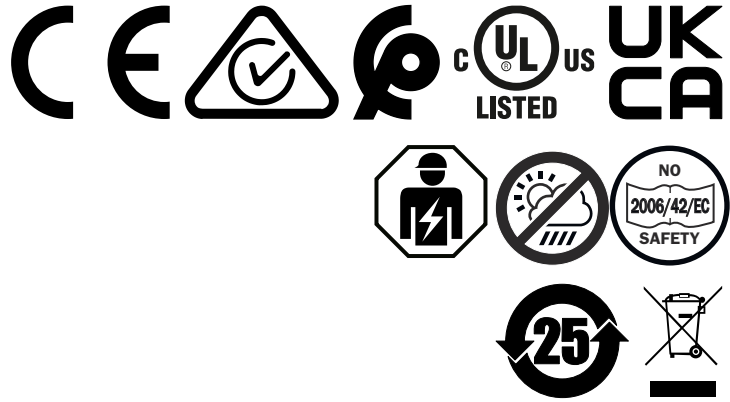

## Contents

<b>1</b>	<b>About this document.....</b>	<b>5</b>
1.1	Information on the operating instructions.....	5
1.2	Symbols and document conventions.....	5
1.3	Further information.....	5
<b>2</b>	<b>Safety information.....</b>	<b>7</b>
2.1	Intended use.....	7
2.2	Improper use.....	7
2.3	Cybersecurity.....	7
2.4	Limitation of liability.....	7
2.5	Modifications and conversions.....	8
2.6	Qualification of personnel.....	8
2.7	Operational safety and specific hazards.....	8
2.8	UL conformity.....	9
<b>3</b>	<b>Product description.....</b>	<b>10</b>
3.1	Product identification via the SICK product ID.....	10
3.2	Scope of delivery.....	10
3.3	Type code.....	10
3.4	Product overview.....	11
<b>4</b>	<b>Transport and storage.....</b>	<b>12</b>
4.1	Transport.....	12
4.2	Unpacking.....	12
4.3	Transport inspection.....	12
4.4	Storage.....	12
<b>5</b>	<b>Mounting.....</b>	<b>13</b>
5.1	Mounting instructions.....	13
5.2	Mounting distances.....	13
5.3	Aligning the device.....	13
<b>6</b>	<b>Electrical installation.....</b>	<b>14</b>
6.1	Wiring instructions.....	14
6.2	Prerequisites for safe operation of the device.....	14
6.3	Pin assignment.....	16
<b>7</b>	<b>Operation.....</b>	<b>18</b>
7.1	Display and control elements.....	18
7.2	Digital output teach-in.....	18
7.2.1	Factory settings of the digital output.....	18
7.2.2	Teaching in the switching point (Single Point Mode, DtO).....	18
7.2.3	Teaching in the switching window (Window Mode).....	19
7.2.4	Teaching in the background (Window Mode $\pm$ 8%, ObSB).....	19
7.3	Resetting the device to factory settings.....	20

7.4	Activating and deactivating the teach-in button.....	20
7.5	IO-Link.....	21
7.6	Establishing a connection to SOPAS ET.....	21
<b>8</b>	<b>Maintenance.....</b>	<b>22</b>
8.1	Maintenance schedule.....	22
8.2	Cleaning.....	22
<b>9</b>	<b>Troubleshooting.....</b>	<b>23</b>
9.1	Repair.....	23
9.2	Return.....	23
9.3	Disposal.....	23
<b>10</b>	<b>Technical data.....</b>	<b>24</b>
10.1	Mechanics/Electronics.....	24
10.2	Performance.....	24
10.3	Interfaces.....	25
10.4	Ambient data.....	25
10.5	Temperature compensation.....	25
10.6	Detection ranges.....	26
10.7	Dimensional drawing.....	28
<b>11</b>	<b>Accessories.....</b>	<b>29</b>
<b>12</b>	<b>Annex.....</b>	<b>30</b>
12.1	Declarations of conformity and certificates.....	30
12.2	Licenses.....	30

# 1 About this document

## 1.1 Information on the operating instructions

Read these operating instructions carefully before starting any work in order to familiarize yourself with the product and its functions.

The operating instructions are an integral part of the product and should remain accessible to the personnel at all times. When handing this product over to a third party, include these operating instructions.

These operating instructions do not provide information on the handling and safe operation of the machine or system in which the product is integrated. Information on this can be found in the operating instructions for the machine or system.

## 1.2 Symbols and document conventions

### Warnings and other notes



#### DANGER

Indicates a situation presenting imminent danger, which will lead to death or serious injuries if not prevented.



#### WARNING

Indicates a situation presenting possible danger, which may lead to death or serious injuries if not prevented.



#### CAUTION

Indicates a situation presenting possible danger, which may lead to moderate or minor injuries if not prevented.



#### NOTICE

Indicates a situation presenting possible danger, which may lead to property damage if not prevented.



#### NOTE

Highlights useful tips and recommendations as well as information for efficient and trouble-free operation.

### Instructions to action

- ▶ The arrow denotes instructions to action.
- 1. The sequence of instructions is numbered.
- 2. Follow the order in which the numbered instructions are given.
- ✓ The tick denotes the results of an action.

## 1.3 Further information

You can find the product page with further information via the SICK Product ID: [pid.sick.com/{P/N}/{S/N}](https://pid.sick.com/{P/N}/{S/N}) (see "Product identification via the SICK product ID", page 10).

The following information is available depending on the product:

- This document in all available language versions
- Data sheets

## 1 ABOUT THIS DOCUMENT

---

- Other publications
- CAD files and dimensional drawings
- Certificates (e.g., declaration of conformity)
- Software
- Accessories

## 2 Safety information

### 2.1 Intended use

The UC12 ultrasonic sensor is used for non-contact detection and distance measurement. Distance measurement is not possible below the operating range of the device.

SICK AG assumes no liability for losses or damage arising from the use of the product, either directly or indirectly. This applies in particular to use of the product that does not conform to its intended purpose and is not described in this documentation.

### 2.2 Improper use

Any use outside of the stated areas, in particular use outside of the technical specifications and the requirements for intended use, will be deemed to be incorrect use.

- The device does not constitute a safety component in accordance with the respective applicable safety standards for machines.
- The device must not be used in explosion-hazardous or corrosive areas or under extreme ambient conditions.
- Any use of accessories not specifically approved by SICK AG is at your own risk.



#### WARNING

##### Danger due to improper use!

Any improper use can result in dangerous situations.

Therefore, observe the following information:

- Product should be used only in accordance with its intended use.
- All information in the documentation must be strictly observed.
- Shut down the product immediately in case of damage.

### 2.3 Cybersecurity

#### Overview

To protect against cybersecurity threats, it is necessary to continuously monitor and maintain a comprehensive cybersecurity concept. A suitable concept consists of organizational, technical, procedural, electronic, and physical levels of defense and considers suitable measures for different types of risks. The measures implemented in this product can only support protection against cybersecurity threats if the product is used as part of such a concept.

You will find further information at [www.sick.com/psirt](http://www.sick.com/psirt), e.g.:

- General information on cybersecurity
- Contact option for reporting vulnerabilities
- Information on known vulnerabilities (security advisories)

### 2.4 Limitation of liability

Relevant standards and regulations, the latest technological developments, and our many years of knowledge and experience have all been taken into account when compiling the information and notes contained in these operating instructions. The manufacturer accepts no liability for damage caused by:

- Non-compliance with product documentation (e.g. operating instructions)
- Improper use
- Use of untrained staff.
- Unauthorized conversions or repair

- Technical modifications
- Use of unauthorized spare parts, wear and tear parts, and accessories

### 2.5 Modifications and conversions

---



#### NOTICE

Modifications and conversions to the device may result in unforeseeable dangers.

---

Interrupting or modifying the device or SICK software will invalidate any warranty claims against SICK AG. This applies in particular to opening the housing, even as part of mounting and electrical installation.

### 2.6 Qualification of personnel

Any work on the product may only be carried out by personnel qualified and authorized to do so.

Qualified personnel are able to perform tasks assigned to them and can independently recognize and avoid any potential hazards. This requires, for example:

- technical training
- experience
- knowledge of the applicable regulations and standards

### 2.7 Operational safety and specific hazards

Please observe the safety notes and the warnings listed here and in other sections of this product documentation to reduce the possibility of risks to health and avoid dangerous situations.

---



#### WARNING

##### Electrical voltage!

Electrical voltage can cause severe injury or death.

- Work on electrical systems must only be performed by qualified electricians.
  - The power supply must be disconnected when attaching and detaching electrical connections.
  - The product must only be connected to a voltage supply as set out in the requirements in the operating instructions.
  - National and regional regulations must be complied with.
  - Safety requirements relating to work on electrical systems must be complied with.
- 



#### WARNING

##### Risk of injury and damage caused by potential equalization currents!

Improper grounding can lead to dangerous equipotential bonding currents, which may in turn lead to dangerous voltages on metallic surfaces, such as the housing. Electrical voltage can cause severe injury or death.

- Work on electrical systems must only be performed by qualified electricians.
  - Follow the notes in the operating instructions.
  - Install the grounding for the product and the system in accordance with national and regional regulations.
-

## 2.8 UL conformity

The UL certification is type-dependent. Any existing UL certification can be found on the type label.



NFPA79 applications only. Adapters including connecting cables are available.

More information can be found on the product page:

The product page can be accessed via the **SICK Product ID: [pid.sick.com/{P/N}/{S/N}](https://pid.sick.com/{P/N}/{S/N})**

**{P/N}** corresponds to the part number of the product, see type label.

**{S/N}** corresponds to the serial number of the product, see type label (if indicated).

### 3 Product description

#### 3.1 Product identification via the SICK product ID

##### SICK product ID

The SICK product ID uniquely identifies the product. It also serves as the address of the web page with information on the product.

The SICK product ID comprises the host name pid.sick.com, the part number (P/N), and the serial number (S/N), each separated by a forward slash.

For many products, the SICK product ID is displayed as text and QR code on the type label and/or on the packaging.

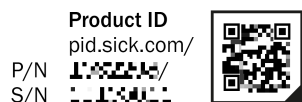

Figure 1: SICK product ID

#### 3.2 Scope of delivery

Table 1: Scope of delivery

No. of units	Component	Note
1	Product in the type ordered	-
1	Printed safety notes, multilingual	Brief information and general safety notes

The actual scope of delivery may differ for special designs, additional orders or due to the latest technical changes.

#### 3.3 Type code

##### Type code structure

UC12 - a b c d e

Position	Description	Characteristic
a	Principle of operation	1: Button operation
b	Detection range	1: 20 mm ... 150 mm 2: 55 mm ... 250 mm
c	Connection technology	2: Male connector M12, 4-pin
d	Housing material	3: Nickel-plated brass
e	Output function	1: 2 PNP (complementary digital outputs) 5: 2 NPN (complementary digital outputs) E: 2 push-pull: PNP/NPN with IO-Link 1.1



##### NOTE

Not all combinations based on type code are possible. The available device types can be found online at [www.sick.com/UC12](http://www.sick.com/UC12).

### 3.4 Product overview

#### Product overview

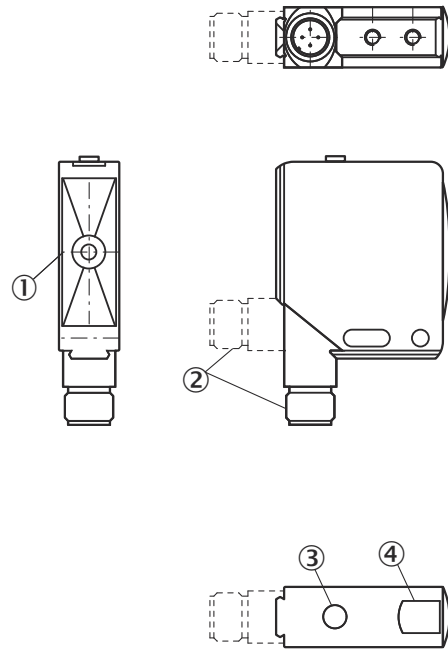

Figure 2: Product overview, UC12

- ① Sending and receiving axis
- ② Connection
- ③ Teach-in button
- ④ Status LED

#### Further topics

- [Dimensional drawing](#)

### 4 Transport and storage

#### 4.1 Transport

**NOTICE****Damage due to improper transport!**

- The product must be packaged with protection against shock and damp.
  - Recommendation: Use the original packaging.
  - Note the symbols on the packaging.
  - Do not remove packaging until immediately before you start mounting.
- 

#### 4.2 Unpacking

- To protect the device against condensation, allow it to equilibrate with the ambient temperature before unpacking if necessary.
- Handle the device with care. Protect against mechanical damage.

#### 4.3 Transport inspection

Immediately upon receipt in incoming goods, check the delivery for completeness and for any damage that may have occurred in transit. In the case of transit damage that is visible externally, proceed as follows:

- Do not accept the delivery or only do so conditionally.
  - Note the extent of damage on the transport documents or on the transport company's delivery note.
  - File a complaint.
- 

**NOTE**

Complaints regarding defects should be filed as soon as these are detected. Damage claims are only valid before the applicable complaint deadlines.

---

#### 4.4 Storage

- Do not store outdoors.
- Store in a place protected from moisture and dust.
- Recommendation: Use the original packaging.
- Do not expose to any aggressive substances.
- Protect from sunlight.
- Avoid mechanical shocks.
- Storage temperature: see ["Technical data", page 24](#).
- For storage periods of longer than 3 months, check the general condition of all components and packaging on a regular basis.

## 5 Mounting

### 5.1 Mounting instructions

- Observe the technical data.
- To prevent condensation, avoid exposing the device to rapid changes in temperature.
- The mounting site has to be designed for the weight of the device.
- When using multiple devices, observe the mounting distance, see "Mounting distances", page 13.

### 5.2 Mounting distances

Device type	Parallel	Opposite
UC12-11xx	> 250 mm	> 1300 mm
UC12-12xx	> 250 mm	> 1400 mm

### 5.3 Aligning the device

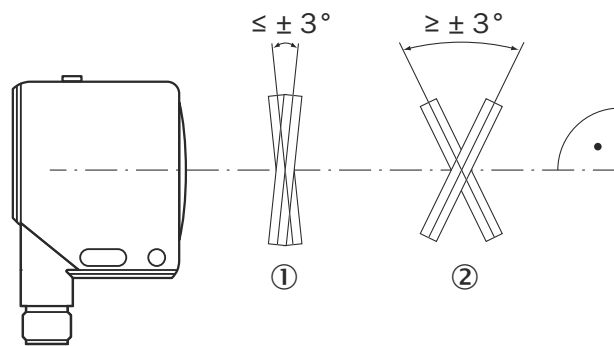

Figure 3: Aligning the device for smooth and rough surfaces

- ① Smooth surface: Angle  $\leq 90^\circ \pm 3^\circ$  between the sensor axis and object surface
- ② Rough surface: Angle  $\geq 90^\circ \pm 3^\circ$  between the sensor axis and object surface

### 6 Electrical installation

#### 6.1 Wiring instructions

**NOTE**

Pre-assembled cables can be found on the product page.

It can be accessed via the **SICK Product ID: [pid.sick.com/{P/N}/{S/N}](https://pid.sick.com/{P/N}/{S/N})**

**{P/N}** corresponds to the part number of the product, see type label.

**{S/N}** corresponds to the serial number of the product, see type label (if specified).

---

**NOTICE****Faults during operation and defects in the device or the system**

Incorrect wiring may result in operational faults and defects.

- Follow the wiring notes precisely.
- 

The enclosure rating stated in the technical data is achieved only with a screwed plug connector or protective cap. Connect the connecting cables in a de-energized state.

Do not switch on the supply voltage until installation is complete and all connecting cables are connected to the device and controller.

The supply voltage must be as specified in the technical data, [see "Technical data", page 24](#).

When commissioning, protect the device from moisture and contamination.

#### 6.2 Prerequisites for safe operation of the device

**WARNING****Risk of injury and damage caused by electrical current!**

As a result of equipotential bonding currents between the device and other grounded devices in the system, faulty grounding of the device can give rise to the following dangers and faults:

- Dangerous voltages are applied to the metal housings.
- Devices will behave incorrectly or be destroyed.
- Cable shielding will be damaged by overheating and cause cable fires.

**Remedial measures**

- Only skilled electricians should be permitted to carry out work on the electrical system.
  - If the cable insulation is damaged, disconnect the voltage supply immediately and have the damage repaired.
  - Ensure that the ground potential is the same at all grounding points.
  - Where local conditions do not meet the requirements for a safe earthing method, take appropriate measures. For example, ensure low-impedance and current-carrying equipotential bonding.
- 

The device is connected to the peripheral devices (any local trigger sensor(s), system controller) via shielded cables. The cable shield – for the data cable, for example – rests against the metal housing of the device.

The device can be grounded through the cable shield or through a blind tapped hole in the housing, for example.

If the peripheral devices have metal housings and the cable shields are also in contact with their housings, it is assumed that all devices involved in the installation have the **same ground potential**.

This is achieved by complying with the following conditions:

- Mounting the devices on conductive metal surfaces.
- Correctly grounding the devices and metal surfaces in the system
- If necessary: Low-impedance and current-carrying equipotential bonding between areas with different ground potentials

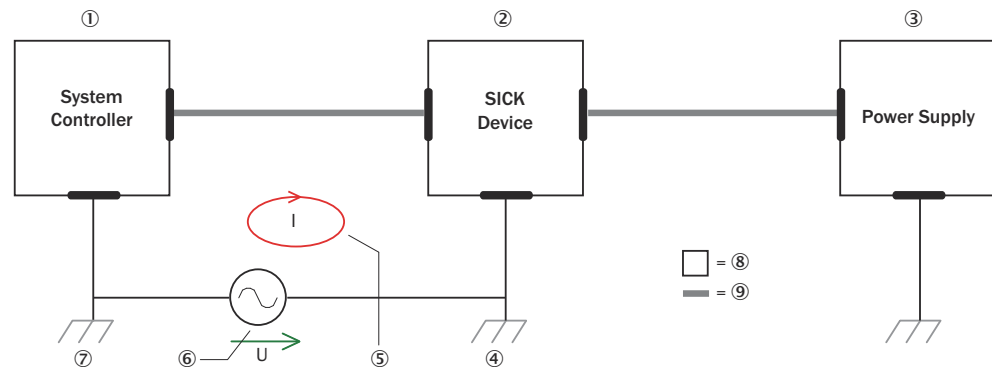

Figure 4: Example: Occurrence of equipotential bonding currents in the system configuration

- ① System controller
- ② Device
- ③ Voltage supply
- ④ Grounding point 2
- ⑤ Closed current loop with equalizing currents via cable shield
- ⑥ Ground potential difference
- ⑦ Grounding point 1
- ⑧ Metal housing
- ⑨ Shielded electrical cable

If these conditions are not fulfilled, equipotential bonding currents can flow along the cable shielding between the devices due to differing ground potentials and cause the hazards specified. This is, for example, possible in cases where there are devices within a widely distributed system covering several buildings.

#### Remedial measures

The most common solution to prevent equipotential bonding currents on cable shields is to ensure low-impedance and current-carrying equipotential bonding. If this equipotential bonding is not possible, the following solution approaches serve as a suggestion.



#### NOTICE

We expressly advise against opening up the cable shields. This would mean that the EMC limit values can no longer be complied with and that the safe operation of the device data interfaces can no longer be guaranteed.

#### Measures for widely distributed system installations

On widely distributed system installations with correspondingly large potential differences, the setting up of local islands and connecting them using commercially available **electro-optical signal isolators** is recommended. This measure achieves a high degree of resistance to electromagnetic interference.

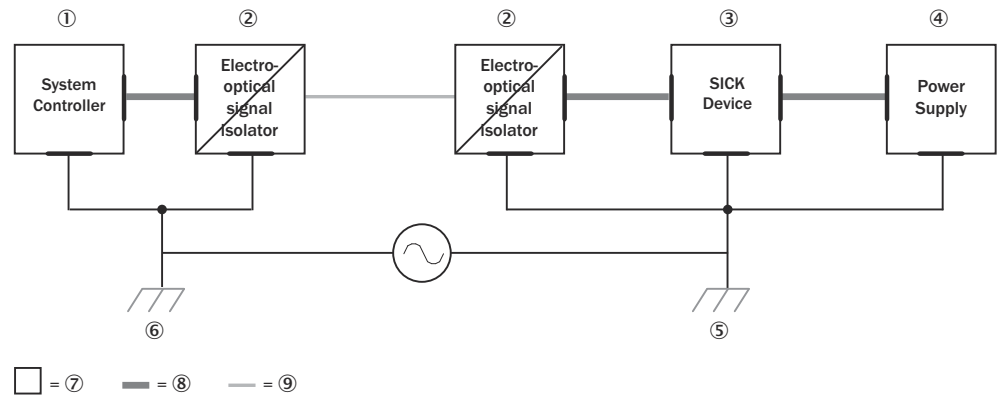

Figure 5: Example: Prevention of equipotential bonding currents in the system configuration by the use of electro-optical signal isolators

- ① System controller
- ② Electro-optical signal isolator
- ③ Device
- ④ Voltage supply
- ⑤ Grounding point 2
- ⑥ Grounding point 1
- ⑦ Metal housing
- ⑧ Shielded electrical cable
- ⑨ Optical fiber

The use of electro-optical signal isolators between the islands isolates the ground loop. Within the islands, a stable equipotential bonding prevents equalizing currents on the cable shields.

**Measures for small system installations**

For smaller installations with only slight potential differences, insulated mounting of the device and peripheral devices may be an adequate solution.

Even in the event of large differences in the ground potential, ground loops are effectively prevented. As a result, equalizing currents can no longer flow via the cable shields and metal housing.



**NOTICE**

The power supply for the device and the connected peripherals must then also ensure the required insulation.

Under certain circumstances, a touchable potential may arise between the insulated metal enclosures and the local earth potential.

**6.3 Pin assignment**

Teach-in via digital output: The first output is complementary to the second output.

UC12-xxxx1, UC12-xxxx5

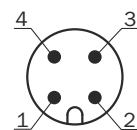

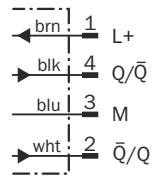

Figure 6: Male connector, M12, 4-pin

Table 2: Pin assignment for UC12-xxxx1, UC12-xxxx5

Contact	Labels	Wire color	Description
1	L+	Brown	Supply voltage, see <a href="#">"Mechanics/Electronics", page 24</a>
2	$\bar{Q}/Q$	White	Inverted digital output / digital output
3	M	Blue	Supply voltage: 0 V
4	$Q/\bar{Q}$	Black	Digital output / inverted digital output

**UC12-xxxxE**

Figure 7: Male connector, M12, 4-pin

Table 3: Pin assignment for UC12-xxxxE

Contact	Labels	Wire color	Description
1	L+	Brown	Supply voltage, see <a href="#">"Mechanics/Electronics", page 24</a>
2	$\bar{Q}/Q$	White	Inverted digital output / digital output
3	M	Blue	Supply voltage: 0 V
4	$Q/\bar{Q}/C$	Black	Digital input / inverted digital output / IO-Link

## 7 Operation

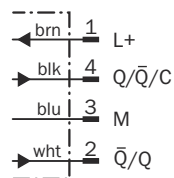
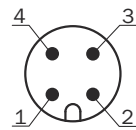
### 7.1 Display and control elements

#### Overview

The device has a status LED that can light up green or orange depending on the operational status.

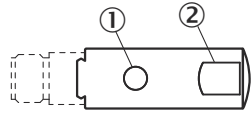

- ① Teach-in button
- ② Status LED

#### Status LED

LED	Status (color)	Status
Status LED	● (Green)	Device ready
	● (Orange)	Digital output active
	☀ (Orange) Flashes quickly for 3 seconds.	<b>Teach-in:</b> <ul style="list-style-type: none"> <li>• No object detected</li> <li>• Object outside the detection range</li> <li>• First switching point within and second switching point outside the detection range <sup>1)</sup></li> </ul> The existing switching points are retained.

● = Lights up; ● = Flashes; ○ = Does not light up.

<sup>1)</sup> Valid for the switching point modes Window Mode and Window Mode ± 8%.

### 7.2 Digital output teach-in

#### 7.2.1 Factory settings of the digital output

- N/O contact
- Switching point at maximum operating range

If one or more digital outputs have been inverted via IO-Link, these inversion settings are reset back to the factory settings by a teach-in on the product (complementary output).

#### 7.2.2 Teaching in the switching point (Single Point Mode, DtO)

##### Overview

When the object is located below the taught-in switching point, the digital output is active.

##### Procedure

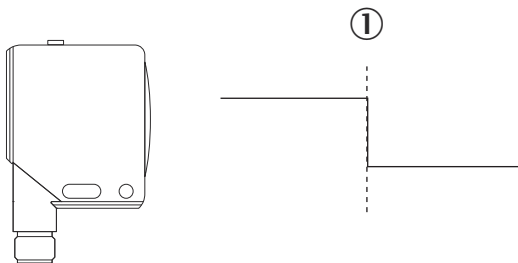

1. Position the object at ①.
2. Press the teach-in button for 2 seconds until the orange LED flashes.
- ✓ The switching point is taught in. The device automatically switches to normal operation mode.

### 7.2.3 Teaching in the switching window (Window Mode)

#### Overview

When the object is located within the taught-in switching window, the digital output is active.

#### Important information



#### NOTE

UC12-xxxx1, UC12-xxxx5: The hysteresis points apply outwards from the configured switching window points.

UC12-xxxxE: The hysteresis points apply inwards from the configured switching window points.

#### Procedure

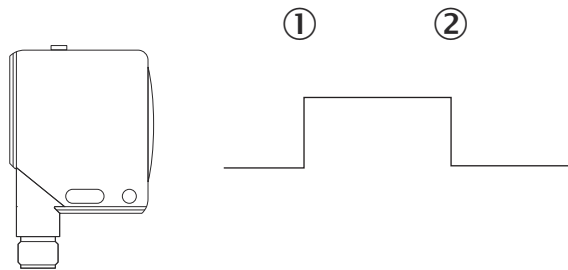

1. Position the object at ①.
2. Press the teach-in button for 5 seconds until the green LED flashes.
- ✓ LED flashes orange and green alternately.
3. Position the object at ②.
- ✓ LED flashes orange and green alternately.
4. Press the teach-in button for 1 second.
- ✓ The switching points are taught-in. The device automatically switches to normal operation mode.

### 7.2.4 Teaching in the background (Window Mode $\pm 8\%$ , ObSB)

#### Overview

When the object is located either below the taught-in background  $-10$  mm (IO-Link:  $-8\%$ ) or above the taught-in background  $+10$  mm (IO-Link:  $+8\%$ ), the digital output is active.

**Procedure**

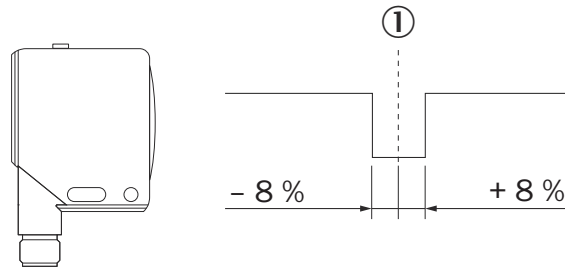

Figure 8: UC12-xxxxE

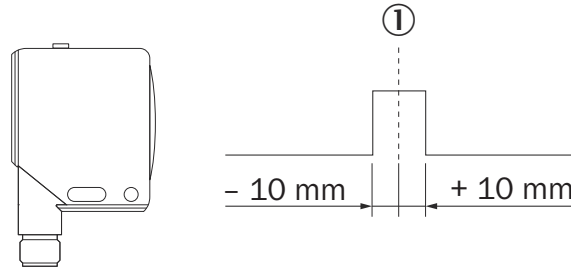

Figure 9: UC12-xxxx1, UC12-xxxx5

1. Position the background at ①.
2. Press the teach-in button for 5 seconds until the green LED flashes.
  - ✓ LED flashes orange and green alternately.
3. Press the teach-in button for 10 seconds until the green LED lights up.
  - ✓ The background is taught-in. The device automatically switches to normal operation mode.

**7.3 Resetting the device to factory settings**

**Procedure**

1. Switch off the supply voltage.
2. While pressing the teach-in button, switch on the supply voltage. Keep pressing and holding down the teach-in button for 13 seconds until the LED lights up permanently orange or green depending on the state of the digital output.
  - ✓ The device is reset to the factory settings. The device automatically switches to normal operation mode.

**7.4 Activating and deactivating the teach-in button**

**Procedure**

1. Switch off the supply voltage.
2. While pressing the teach-in button, switch on the supply voltage. Press and hold down the teach-in button for 5 seconds until the orange LED flashes.
  - ✓ Teach-in button activated: LED flashes orange quickly.
  - ✓ Teach-in button deactivated: LED flashes green quickly.
3. To change the setting, press the teach-in button for 1 second.
  - ✓ The flashing LED changes color.
4. Wait 10 seconds.
  - ✓ The device automatically switches to normal operation mode.

## 7.5 IO-Link

Depending on the product type, the product can exchange process data and parameters via IO-Link. To do this, connect the product to a suitable IO-Link Master. A sensor-specific device description file (IODD) is required in the IO-Link Master. The IODD and a supplementary information document are available on the product page.

The product page can be accessed via the **SICK Product ID: [pid.sick.com/{P/N}/{S/N}](http://pid.sick.com/{P/N}/{S/N})**

**{P/N}** corresponds to the part number of the product, see type label.

**{S/N}** corresponds to the serial number of the product, see type label (if indicated).

## 7.6 Establishing a connection to SOPAS ET

### Overview

The SOPAS Engineering Tool (SOPAS ET) software is suitable for parameterization as well as for service and diagnostics purposes.

### Prerequisites

- Product type with IO-Link
- A computer with the SOPAS ET software installed on it, and a free USB 2.0 compatible port



### NOTE

The most up-to-date version of the SOPAS ET software can be downloaded from [www.sick.com/SOPAS\\_ET](http://www.sick.com/SOPAS_ET). The respective system requirements for installing SOPAS ET are also specified there.

- SICK SiLink2 Master (available as accessory)
- Connection cable with M12 male and female connectors, 4-pin (available as accessory)
- Device description file (SDD)



### NOTE

The SDD can be installed in SOPAS ET or via the SICK website. Follow the instructions in SOPAS ET.

### Procedure

1. Connect the product to the SiLink2 Master via the male connector or an additional connection cable.
2. Connect the SiLink2 Master to the computer using the supplied USB cable.
3. Switch on and start the computer.
4. To ensure an adequate voltage supply to the product, also connect the enclosed wall plug to the SiLink2 Master.
- ✓ The status LEDs light up green after successful initialization. The product is ready for operation.
5. Install the device description file.
6. Select the product from the device catalog and add it to a project.
- ✓ A connection to the product is established via the communication interface. The connection must be activated for data transmission (**online**).

## 8 Maintenance

### 8.1 Maintenance schedule

During operation, the device is maintenance-free.

Table 4: Maintenance schedule

Maintenance work	Interval	To be carried out by
Check device and connecting cables for damage at regular intervals.	Depends on ambient conditions and climate.	Specialist
Check the screw connections and plug connections.	Depends on the place of use, ambient conditions or operating requirements. Recommended: At least every 6 months.	Specialist

### 8.2 Cleaning



#### NOTICE

##### Equipment damage due to improper cleaning.

Improper cleaning may result in equipment damage.

- Only use recommended cleaning agents and tools.
- Never use sharp objects for cleaning.

## 9 Troubleshooting

### 9.1 Repair

Repairs on the device may only be performed by qualified and authorized personnel from SICK AG. Interference with or modifications to the device on the part of the customer will invalidate any warranty claims against SICK AG.

### 9.2 Return

- ▶ Only send in devices after consulting with SICK Service.
- ▶ The device must be sent in the original packaging or an equivalent padded packaging.



#### NOTE

To enable efficient processing and allow us to determine the cause quickly, please include the following when making a return:

- Details of the contact person
  - Description of the application
  - Description of the error that occurred
- 

### 9.3 Disposal

If a device can no longer be used, dispose of it in an environmentally friendly manner in accordance with the applicable country-specific waste disposal regulations. Do not dispose of the product along with household waste.



#### NOTICE

**Danger to the environment due to improper disposal of the device.**

Disposing of devices improperly may cause damage to the environment.

Therefore, observe the following information:

- Always observe the national regulations on environmental protection.
  - Separate the recyclable materials by type and place them in recycling containers.
-

## 10 Technical data

### 10.1 Mechanics/Electronics

Supply voltage $V_s$	DC 10 V ... 30 V <sup>1)</sup>
Power consumption	$\leq 1.2$ W <sup>2)</sup>
Initialization time	< 300 ms
Design	Cuboid
Housing material	Metal (zinc die cast) Ultrasonic converter: Polyurethane foam, epoxy resin with glass content
Connection type	Male connector, M12, 4-pin
Display	1 x LED
Weight	75 g
Sending axis	Straight
Dimensions (W x H x D)	15 mm x 48.8 mm x 43.5 mm
Enclosure rating	IP65 / IP67 (EN 60529)
Protection class	III

1) Limit values, reverse-polarity protected Operation in short-circuit protected network: max. 8 A.

2) Without load.

### 10.2 Performance

Operating range	UC12-1123x: 20 mm ... 150 mm UC12-1223x: 55 mm ... 250 mm
Limiting range	UC12-1123x: 250 mm UC12-1223x: 350 mm
Measuring object	Natural objects
Resolution	$\geq 0.1$ mm
Repeatability	$\pm 0.15\%$ <sup>1)</sup>
Accuracy	$\pm 1\%$ <sup>2)</sup>
Temperature compensation	✓
Response time	30 ms
Switching frequency	25 Hz
Output time	8 ms
Ultrasonic frequency (typical)	UC12-1123x: 380 kHz UC12-1223x: 500 kHz
Detection range (typical)	<a href="#">Detection ranges</a>
Additional function	<ul style="list-style-type: none"> <li>Configurable switching point modes: Single Point Mode (DtO), Window Mode (switching window), Window Mode <math>\pm 8\%</math> (ObSB)</li> <li>Teachable digital output</li> <li>Teach-in button (can be deactivated)</li> <li>Reset to factory settings</li> </ul>

1) Relative to the current measured value, minimum value  $\geq$  resolution.

2) Relative to the current measured value.

### 10.3 Interfaces

<b>IO-Link</b>	UC12-1x23E: IO-Link V1.1 Function: Process data, parameterization, diagnostics, data storage
<b>digital output</b>	UC12-11231: 2 PNP (complementary digital outputs Q, $\bar{Q}$ ) <sup>1)</sup> , maximum output current $I_A \leq 500$ mA UC12-11235: 2 NPN (complementary digital outputs Q, $\bar{Q}$ ) <sup>2)</sup> , maximum output current $I_A \leq 500$ mA UC12-1x23E: Push-pull: PNP/NPN <sup>3)</sup> (complementary digital outputs Q, $\bar{Q}$ ), maximum output current $I_A \leq 100$ mA
<b>Hysteresis</b>	2 mm

1) PNP: HIGH =  $U_V - (< 2 \text{ V})$  / LOW = 0 V.

2) NPN: HIGH  $\leq 2 \text{ V}$  / LOW =  $U_V$ .

3) Push-pull: PNP/NPN: HIGH =  $U_V - (< 0.6 \text{ V})$  / LOW =  $< 0.6 \text{ V}$ .

### 10.4 Ambient data

<b>Ambient operating temperature</b>	-25 °C ... +70 °C
<b>Storage temperature</b>	-40 °C ... +85 °C

### 10.5 Temperature compensation

#### UC12-xxxx1, UC12-xxxx5

The internal temperature compensation reaches the optimal operating point after an uptime of 30 minutes.

#### UC12-xxxxE

The internal temperature compensation reaches the optimal operating point after an uptime of 2 minutes. Temperature compensation is adjusted at the factory to standard mounting conditions with an aluminum mounting bracket and mounting nuts.

Temperature compensation is automatically adjusted to the individual installation situation under the following conditions.

#### Conditions of automatic adjustment of temperature compensation

- The device is in a cold state.
- Digital output: The digital output is deactivated for approx. 30 minutes.

If the measured value changes in the 30 minutes, the adjustment is canceled. The default parameters or the last adjusted parameters are retained. Automatic adjustment is suitable for installation situations that deviate greatly from standard installation conditions or where high measurement accuracy is required. One example is thermally insulated mounting.

10.6 Detection ranges

UC12-112x

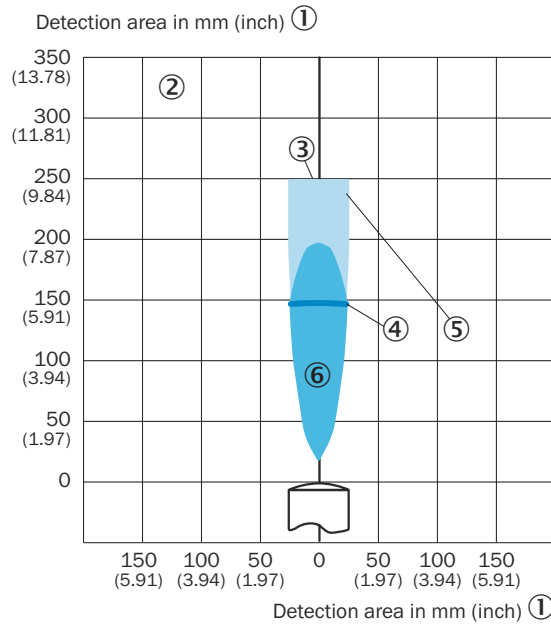

- ① Detection range in mm (inch)
- ② Detection range dependent on reflection properties, size, and alignment of the object
- ③ Limiting range
- ④ Operating range
- ⑤ Example object: aligned plate 10 mm x 10 mm
- ⑥ Example object: cylindrical bar with a diameter of 10 mm

**UC12-122x**

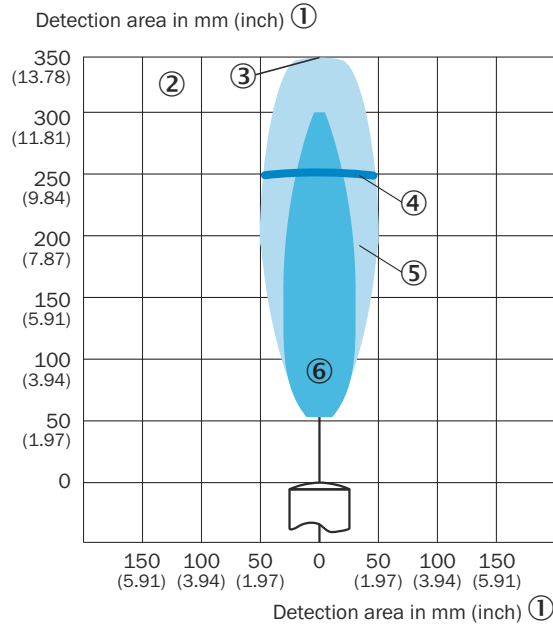

- ① Detection range in mm (inch)
- ② Detection range dependent on reflection properties, size, and alignment of the object
- ③ Limiting range
- ④ Operating range
- ⑤ Example object: aligned plate 10 mm x 10 mm
- ⑥ Example object: cylindrical bar with a diameter of 10 mm

10.7 Dimensional drawing

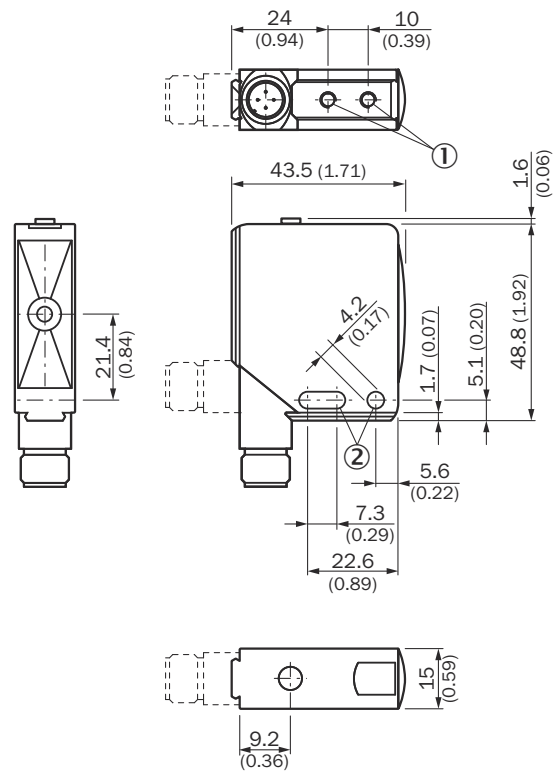

Figure 10: structure and device dimensions, unit: mm (inch), decimal separator: period

- ① M4 threaded mounting hole, 4 mm depth
- ② Fixing hole

## 11 Accessories

---

**NOTE**

On the product page you will find accessories and, if applicable, related installation information for your product.

The product page can be accessed via the **SICK Product ID: [pid.sick.com/{P/N}/{S/N}](https://pid.sick.com/{P/N}/{S/N})**

**{P/N}** corresponds to the part number of the product, see type label.

**{S/N}** corresponds to the serial number of the product, see type label (if indicated).

---

## 12 Annex

### 12.1 Declarations of conformity and certificates

You can download declarations of conformity and certificates via the product page.

The product page can be accessed via the **SICK Product ID: [pid.sick.com/{P/N}/{S/N}](http://pid.sick.com/{P/N}/{S/N})**

**{P/N}** corresponds to the part number of the product, see type label.

**{S/N}** corresponds to the serial number of the product, see type label (if indicated).

### 12.2 Licenses

SICK uses open source software which is published by the rights holders under a free license. Among others, the following license types are used: GNU General Public License (GPL version 2, GPL version 3), GNU Lesser General Public License (LGPL), MIT license, zlib license and licenses derived from the BSD license.

This program is provided for general use without warranty of any kind. This warranty disclaimer also extends to the implicit assurance of marketability or suitability of the program for a particular purpose.

More details can be found in the GNU General Public License.

For license texts see [www.sick.com/licensetexts](http://www.sick.com/licensetexts).

Printed copies of the license texts are also available on request.



**Australia**

Phone +61 (3) 9457 0600  
1800 33 48 02 – tollfree  
E-Mail sales@sick.com.au

**Austria**

Phone +43 (0) 2236 62288-0  
E-Mail office@sick.at

**Belgium/Luxembourg**

Phone +32 (0) 2 466 55 66  
E-Mail info@sick.be

**Brazil**

Phone +55 11 3215-4900  
E-Mail comercial@sick.com.br

**Canada**

Phone +1 905.771.1444  
E-Mail cs.canada@sick.com

**Czech Republic**

Phone +420 234 719 500  
E-Mail sick@sick.cz

**Chile**

Phone +56 (2) 2274 7430  
E-Mail chile@sick.com

**China**

Phone +86 20 2882 3600  
E-Mail info.china@sick.net.cn

**Denmark**

Phone +45 45 82 64 00  
E-Mail sick@sick.dk

**Finland**

Phone +358-9-25 15 800  
E-Mail sick@sick.fi

**France**

Phone +33 1 64 62 35 00  
E-Mail info@sick.fr

**Germany**

Phone +49 (0) 2 11 53 010  
E-Mail info@sick.de

**Greece**

Phone +30 210 6825100  
E-Mail office@sick.com.gr

**Hong Kong**

Phone +852 2153 6300  
E-Mail ghk@sick.com.hk

**Hungary**

Phone +36 1 371 2680  
E-Mail ertekebsites@sick.hu

**India**

Phone +91-22-6119 8900  
E-Mail info@sick-india.com

**Israel**

Phone +972 97110 11  
E-Mail info@sick-sensors.com

**Italy**

Phone +39 02 27 43 41  
E-Mail info@sick.it

**Japan**

Phone +81 3 5309 2112  
E-Mail support@sick.jp

**Malaysia**

Phone +603-8080 7425  
E-Mail enquiry.my@sick.com

**Mexico**

Phone +52 (472) 748 9451  
E-Mail mexico@sick.com

**Netherlands**

Phone +31 (0) 30 204 40 00  
E-Mail info@sick.nl

**New Zealand**

Phone +64 9 415 0459  
0800 222 278 – tollfree  
E-Mail sales@sick.co.nz

**Norway**

Phone +47 67 81 50 00  
E-Mail sick@sick.no

**Poland**

Phone +48 22 539 41 00  
E-Mail info@sick.pl

**Romania**

Phone +40 356-17 11 20  
E-Mail office@sick.ro

**Singapore**

Phone +65 6744 3732  
E-Mail sales.gsg@sick.com

**Slovakia**

Phone +421 482 901 201  
E-Mail mail@sick-sk.sk

**Slovenia**

Phone +386 591 78849  
E-Mail office@sick.si

**South Africa**

Phone +27 10 060 0550  
E-Mail info@sickautomation.co.za

**South Korea**

Phone +82 2 786 6321/4  
E-Mail infokorea@sick.com

**Spain**

Phone +34 93 480 31 00  
E-Mail info@sick.es

**Sweden**

Phone +46 10 110 10 00  
E-Mail info@sick.se

**Switzerland**

Phone +41 41 619 29 39  
E-Mail contact@sick.ch

**Taiwan**

Phone +886-2-2375-6288  
E-Mail sales@sick.com.tw

**Thailand**

Phone +66 2 645 0009  
E-Mail marcom.th@sick.com

**Turkey**

Phone +90 (216) 528 50 00  
E-Mail info@sick.com.tr

**United Arab Emirates**

Phone +971 (0) 4 88 65 878  
E-Mail contact@sick.ae

**United Kingdom**

Phone +44 (0)17278 31121  
E-Mail info@sick.co.uk

**USA**

Phone +1 800.325.7425  
E-Mail info@sick.com

**Vietnam**

Phone +65 6744 3732  
E-Mail sales.gsg@sick.com

Detailed addresses and further locations at [www.sick.com](http://www.sick.com)