



LEVEL INDICATOR

PFGLP

Product Line: **Floating**



Liquids



Food products



Corrosives

Float level indicator for the detection of liquids inside tanks or batching cells. All parts in contact with the product are in stainless steel.

ADVANTAGES

- An **EASY TO INSTALL** instrument that does not require any calibration, maintenance or specific tool for its installation.
- **DURABLE** and **RELIABLE** with aluminium casing and electrical connection via anti-vibration faston terminals. Works with ambient temperatures from -20° to +70°C.



ATEX
DUST ZONE 21
GAS ZONE 1



European Union
Conformity



United Kingdom
Conformity

AVAILABLE VERSIONS



PFGLPC

Curved version



ATEX
DUST ZONE 21
GAS ZONE 1



PFGLP22

Version with
G 2" thread



PFGLP22C

Curved version
with G 2" thread



ATEX
DUST ZONE 22

LEVEL INDICATOR PFGLP



Liquids



Food products



Corrosives

Product Line: **Floating**

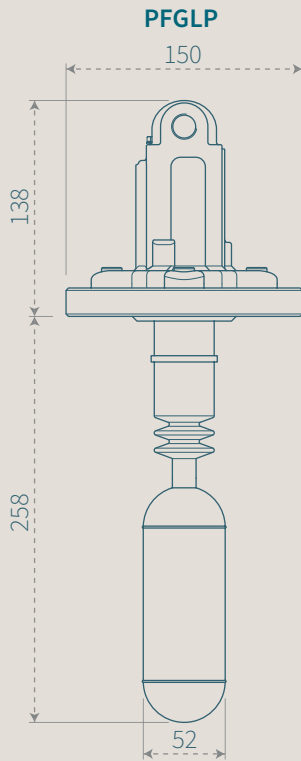

PFGLP22

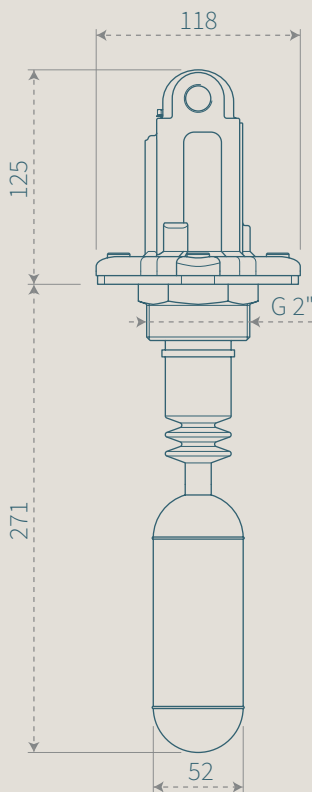

Customizations

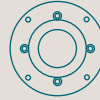

Stainless steel flange

PFGLP22 ONLY



Stainless steel sleeve G 2"

PFGLP22 ONLY



Stainless steel extension up to 500 mm



Curved float

