

Installation and Maintenance Rules for: **PFG-LP22 float level gauges for liquids** PFG-LP22/F - PFG-LP22/F/C - PFG-LP22/M - PFG-LP22/M/C

STANDARD FEATURES

The float level gauge PFG-LP22 is made in compliance with the regulations in force in the European Union and specifically with:

- Die-cast aluminium casing UNI 5076. IP65 protection.
- Parts in contact with the products are made of stainless steel.
- Use contact capacity: 10 A at 250 V AC.
- Operating temperature: from -10 to +100 °C.
- Maximum working pressure: 25 bar.
- PFG-LP22/F - PFG-LP22/M standard.
- PFG-LP22/F/C - PFG-LP22/M/C with curved float.

SAFETY RULES

All the appropriate safety precautions must be taken when electrically operated equipment is used, in order to reduce the risk of fire outbreaks, electric shock and injuries to persons.

- Keep the work zone clean and orderly. Accidents are more likely to occur in untidy areas and environments.
- Before beginning work, make sure that the level gauge is in a perfect condition. Damaged or broken parts must be repaired or replaced by competent personnel authorized by the Manufacturer.
- All verifications, inspections, cleaning and maintenance operations, part changes and replacement must be carried out with the level gauge disconnected.
- It is absolutely forbidden for children, unauthorized and/or inexpert persons to touch or use the level gauge.
- Make sure that the earthing is efficiently connected when the instrument is installed.
- Periodically check to be sure that the cable is in a perfect condition and replace it if is damaged. This operation must only be carried out by competent and authorized persons. Only use extension cables of the permitted type and marked.
- Protect the cable against high temperatures, lubricants and sharp edges. Do not twist or knot the cable.
- Do not allow children or unauthorized persons to touch the cable.

DESCRIPTION

PFG-LP22 is a float level gauge used to detect the level of liquids in tanks.

It operates by means of a float centered to the fixed support on the flange or sleeve. The float moves as the level of the liquid increases and this movement is transmitted to a microswitch housed in the body of the gauge, causing its electric contact to change status.

The instrument consists of a die-cast aluminium casing housing a precision microswitch and a rocker device controlled by magnetic induction that activates the microswitch. This casing is en bloc with the flange or sleeve that fixes the instrument which in turn supports the float that tests the liquid.

The centering articulation of the float is protected by an elastic casing in Neoprene which prevents sticky substances from accumulating within the articulation itself, since this could hamper its movement.

All parts in contact with the liquid (flange, sleeve, articulation and float) are made of stainless steel to prevent problems if the treated liquid is aggressive.

OPERATION

When it is not operating, the float assumes a negatively slanting position of about 10° in relation to its horizontal axis.

As the level of the liquid rises, the float is influenced by the movement and shifts from its initial position until it slants positively by about 10° in relation to its horizontal axis (Fig.1).

This movement is transmitted by magnetic induction by the magnet fixed to the float, to the rocker device in the body of the instrument which activates the microswitch.

There is no more or less protected passage between the liquid in the tank and the interior part of the level gauge since magnetic induction is transmitted to a lowered part of the stainless steel flange or sleeve, thus guaranteeing 100% impermeability.

The microswitch is a switch contact type.

INSTALLATION

The gauge is mounted on the external wall of the tank by means of a counterflange or sleeve sized as shown in the drawing (see REFERENCE FIGURES).

The horizontal axis of the float must be perpendicular to the tank wall, thus parallel to the surface of the still liquid.

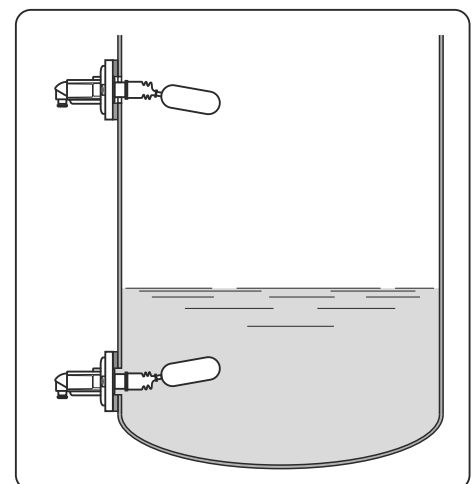

Fig.1

Equipped with a float with a curved stem, gauge PFG-LP22-C can be mounted on tank walls slanting 45° at most, since the curved stem achieves optimum operating conditions just as through the float was parallel to the surface of the liquid (Fig.2).

ELECTRICAL WIRING

The conductors forming the signal carrying cable connected to the microswitch (Fig.3) must have an adequate cross-section so that the current density, in each conductor, is no higher than 4 A/mm². One of these is used only for the earthing of the level gauge.

The cross-section of the conductors must also be adequate in relation to the length of the cable used to avoid a drop in voltage along the cable over the values prescribed by the regulations on the subject.

It is likewise recommended to use flexible cables with an adequate outside diameter for the fair-leads used (not supplied) to ensure a perfect seal of the cable clamp on the signal carrying cable.

Use exclusively cable entries certified according to directive 2014/34/EU, and standard EN 60079-31:2014.

Use Faston cable terminals to connect the microswitch terminals and the ground connection.

CAUTION: In the terminal board compartment, the connection for Faston type terminal whose position is marked by the ground symbol on the printed circuit (Fig.3) is used for the earthing the level gauge. The yellow-green conductor (green only for the USA) of the signal carrying cable must be connected to this terminal.

The ground connection of the float level gauge PFG-LP22, through the yellow-green conductor, is compulsory.

On the external level gauge casing side, placed side by side to the cable inlet, a second connection point is present for the external ground connection executable with a screw M5 and an eyelet cable terminal.

- The external earthing has to be carried out by the installer.
- The equipment has to be protected against impact and electrostatic inside the tank.
- The user has to protect the equipment circuits with fuses against short circuit.
- The max. surface temperature is without dust and not safety distance.

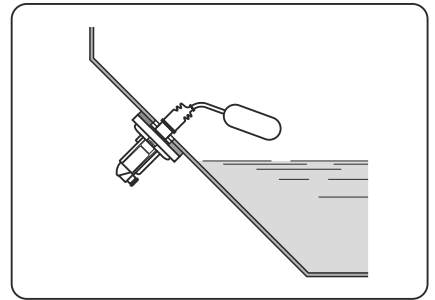

Fig.2

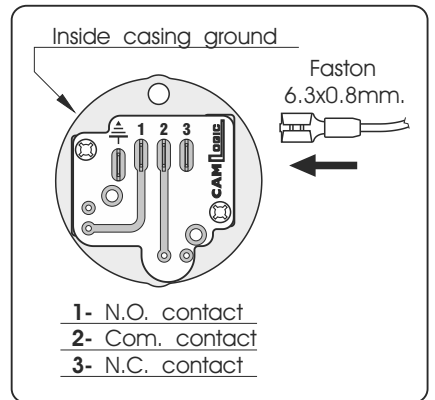
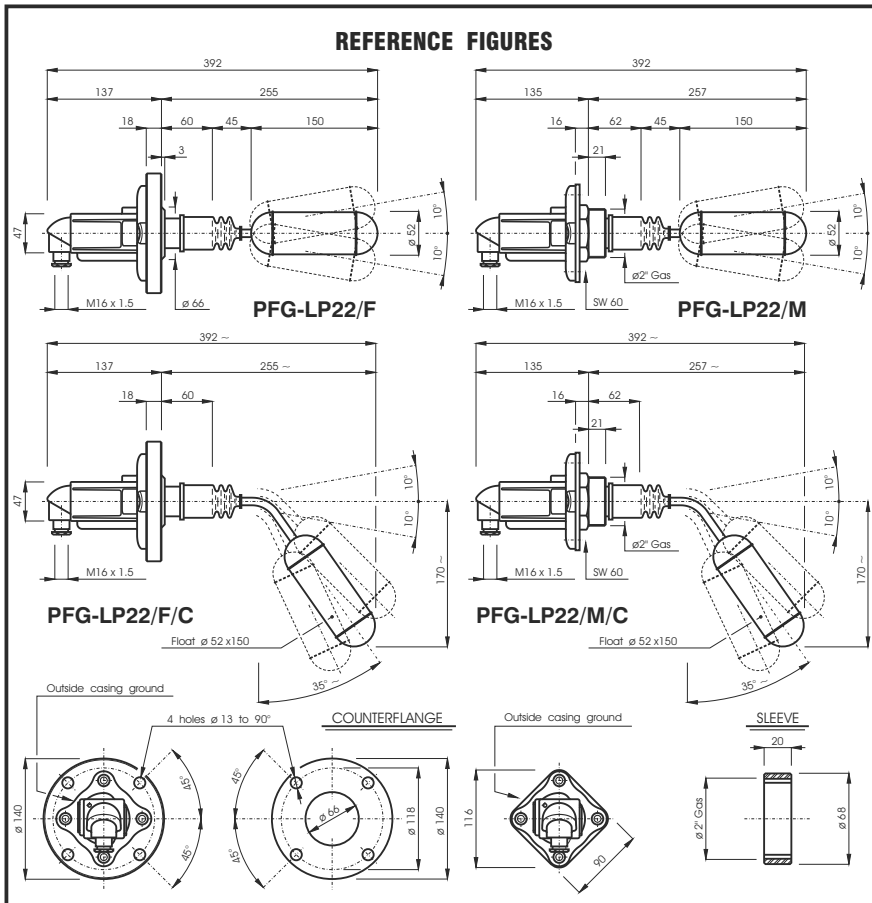

Fig.3



MAINTENANCE

CAMLogic float level gauges for liquids need no routine maintenance.

WARRANTY

CAMLogic, in addition to the terms of the supply contract, guarantees its products for a period of twenty-four (24) months from the date of shipment.

This warranty is expressed only in the repair or replacement free of charge of parts that, after careful examination by the Manufacturer, turn out to be defective. Warranty, excluding all liability for direct or indirect damage, is considered to be restricted to only defects in materials and has no effect if the parts returned turn out to have been anyhow dismantled, tampered with or repaired by anyone other than the Manufacturer.

Warranty likewise excludes damage deriving from negligence, carelessness, bad or improper use of the level gauge, or from bad handling by the operator and faulty installation.

Warranty is moreover forfeit if non-genuine spare parts have been used.

A returned level gauge, even if under warranty, must be shipped carriage free.

EU DECLARATION OF CONFORMITY

The manufacturer CAMLogic declares under its own responsibility that the product PFG-LP22/. answers to the requisites of the European Directive 2014/34/EU in consideration of the standards: EN IEC 60079-0:2018 and EN 60079-31:2014.

Marking : Ⓜ II 3 D Ex tc IIIB T135°C Dc - The permitted range ambient temperature is -10 to +100 °C.

Declaration of conformity: CL 20 ATEX 0705.

The application zone is the 22.

Instructions Manual No. 01248 11.06 - Rev. 01 All the information contained in this manual is confidential and no part of it may be disclosed without written authorization from CAMLogic.

This manual, even after the sale of the level gauge, is lent and remains the property of the Manufacturer.