

# 9400



E94AxHExxxx

Servo Drives 9400 HighLine \_\_\_\_\_

Reference manual

EN



135569496

**Lenze**

# Overview of technical documentation for Servo Drives 9400

---

## Project planning, selection & ordering

- 9400 hardware manual
- Catalogue / electronic catalogue (DSC - Drive Solution Catalogue)

## Mounting & wiring

- MA 9400 StateLine/HighLine
- MA for the communication module
- MA for the extension module
- MA for the safety module
- MA for the accessories
- MA for remote maintenance components

## Parameter setting

- BA keypad
- SW for the »Engineer« Lenze software
- SW - controller** (9400 StateLine/HighLine/PLC)
- SW for the regenerative power supply module
- KHB for the communication module
- SW for the extension module
- SW for the safety module
- SW for the Lenze technology application
- SW for the 9400 function library

← This documentation

## Configuring & programming

- SW for the »Engineer« Lenze software
- SW for the »PLC Designer« Lenze software
- SW - controller** (9400 HighLine/PLC)
- KHB for the communication module
- SW for the extension module
- SW for the safety module
- SW for the Lenze technology application
- SW for the 9400 function library

← This documentation

## Drive commissioning

- Commissioning guidelines
- SW - controller** (9400 StateLine/HighLine/PLC)
  - Chapter "[Commissioning](#)" ([📖 25](#))
  - Chapter "[Oscilloscope](#)" ([📖 585](#))
  - Chapter "[Diagnostics & fault analysis](#)" ([📖 608](#))
- Remote maintenance manual

← This documentation

## Networking

- KHB for the communication medium used

## Legend:

- Printed documentation
- Online documentation (PDF/Engineer online help)

## Abbreviations used:

- BA Operating instructions
- KHB Communication manual
- MA Mounting instructions
- SW Software manual

# Contents

---

<b>1</b>	<b>About this document</b>	<b>13</b>
1.1	Conventions used	15
1.2	Terminology used	16
1.3	Definition of the notes used	17
<b>2</b>	<b>Introduction</b>	<b>18</b>
2.1	Parameter setting, configuring, or programming?	18
2.1.1	Basic functionalities	19
2.1.2	Technology applications	19
2.2	Communicating with the controller	20
2.2.1	Going online via diagnostic adapter	20
2.2.2	Going online via system bus (CAN on board)	23
2.2.3	Use of other communication interfaces	23
2.3	Signal types & scaling	24
<b>3</b>	<b>Commissioning</b>	<b>25</b>
3.1	General notes	26
3.2	Notes on commissioning using the keypad	27
3.3	Initial commissioning	28
3.4	Standard set-up	29
3.5	Controller replacement	30
3.6	Motor replacement	30

# Contents

---

<b>4</b>	<b>Drive interface</b>	<b>31</b>
4.1	Machine parameters	32
4.1.1	Mains voltage	33
4.1.2	Gearbox ratio	34
4.1.3	Motor mounting direction	35
4.1.4	Feedback configuration	35
4.1.5	Unit/user-defined unit	36
4.1.6	Traversing range	37
4.1.7	Feed constant	39
4.1.8	Resolution of an encoder revolution	40
4.1.9	Max. position, speed, and acceleration that can be displayed internally	43
4.2	Device commands	45
4.2.1	Load Lenze setting	47
4.2.2	Load start parameters	48
4.2.3	ENP:Load plant data	49
4.2.4	Activate application	50
4.2.5	Save selected application	51
4.2.6	Save start parameters	52
4.2.7	Delete logbook	54
4.2.8	Archive logbook	55
4.2.9	Start application	56
4.2.10	Stop application	57
4.2.11	Reset program	58
4.2.12	Delete program	59
4.2.13	Restart program	60
4.2.14	Reset runtime measurement	61
4.2.15	Inhibit controller	63
4.2.16	Enable controller	64
4.2.17	Reset error	65
4.2.18	Activate quick stop	66
4.2.19	Reset quick stop	67
4.2.20	Identify pole position (360°)	68
4.2.21	Identify pole position (min. motion)	69
4.2.22	Resolver error identification	71
4.2.23	Load Lenze INV characteristic	72
4.2.24	Calculate inv. characteristic	73
4.2.25	Determine motor parameters	74
4.2.26	Calculate current controller parameters	75
4.2.27	Calculate speed controller parameters	77
4.2.28	CAN on board: Reset Node	78
4.2.29	CAN module: Reset node	79
4.2.30	CAN on board: Pred.Connect.Set	80
4.2.31	CAN module: Pred.Connect.Set	81
4.2.32	CAN on board: Identify node	82
4.2.33	CAN module: Identify node	83
4.2.34	Unbind/bind Ethernet module MXI1	84
4.2.35	Unbind/bind Ethernet module MXI2	85
4.2.36	Activate parameter set 1 ... 4	86
4.2.37	Activate parameter set 1 ... 4	88
4.2.38	Load cam data	90
4.2.39	Save cam data	92
4.2.40	Calculate cam data	94
4.2.41	Calculate cam data checksum	95
4.2.42	Format file system	96
4.2.43	Restore file system	97

# Contents

---

4.2.44	Prepare firmware update	98
4.2.45	Restart controller	99
4.3	Device states	100
4.3.1	"Initialisation active" state	102
4.3.2	"Safe torque off active" state	103
4.3.3	"Device is ready to switch on" state	103
4.3.4	"Device is switched on" state	104
4.3.5	"Operation" state	104
4.3.6	"Warning active"	105
4.3.7	"Warning locked active"	105
4.3.8	"Quick stop by trouble active" state	105
4.3.9	"Trouble active" state	106
4.3.10	"Fault active" state	106
4.3.11	"System fault active" state	106
4.4	Automatic restart after mains connection/trouble...	107
4.5	Behaviour after task overflow	109
4.6	Device output power	110
4.6.1	Switching frequency	110
4.6.2	Monitoring of the device utilisation	111
4.6.3	Operation with increased continuous power	112
4.7	Internal interfaces   "LS_DriveInterface" system block	113
4.7.1	Status signals	116
4.7.2	Monitoring of external events	117

# Contents

---

<b>5</b>	<b>Motor interface</b>	<b>118</b>
5.1	General information	120
5.1.1	Reading out motor data from the controller	120
5.1.2	Selecting a motor from the motor catalogue in the »Engineer«	121
5.1.3	Displaying/editing motor data in »Engineer«	122
5.2	Select motor control	124
5.3	Adjusting motor and controller to each other	126
5.3.1	Accepting/adapting plant parameters	127
5.3.2	Parameterising motor encoder	129
5.3.3	Pole position identification	131
5.3.4	Optimising the switching performance of the inverter	138
5.3.5	Determining the motor parameters	141
5.4	Servo control (SC)	145
5.4.1	Optimising the control mode	146
5.4.2	Signal flow (servo control for synchronous motor)	162
5.4.3	Signal flow (servo control for asynchronous motor)	164
5.5	Sensorless vector control (SLVC)	166
5.5.1	Basic settings	167
5.5.2	Optimising motor parameters	169
5.5.3	Optimising the control mode	175
5.5.4	Signal flow	183
5.6	V/f control (VFCplus)	184
5.6.1	Basic settings	184
5.6.2	Optimising the control mode	191
5.6.3	Signal flow	199
5.7	V/f control (VFCplus)	200
5.7.1	Signal flow	201
5.8	Parameterisable additional functions	203
5.8.1	Correction of the stator leakage inductance...	204
5.8.2	Field weakening for synchronous machines	209
5.8.3	Flying restart function	212
5.8.4	DC-injection braking	215
5.9	Monitoring	217
5.9.1	Signal flow	217
5.9.2	Motor monitoring ( $I^2xt$ )	218
5.9.3	Motor temperature monitoring	225
5.9.4	Motor phase failure monitoring	229
5.9.5	Maximum current monitoring	233
5.10	Internal interfaces   "LS_MotorInterface" system block	234

# Contents

---

<b>6</b>	<b>Encoder evaluation</b>	239
6.1	Internal interfaces   "LS_Feedback" system block	240
6.1.1	Use of an external position encoder	242
6.2	Signal flow	243
6.3	Parameter setting	243
6.3.1	Controller configuration	246
6.3.2	System with motor encoder	248
6.3.3	System with motor encoder and position encoder	249
6.3.4	Position feedback with a linear distance measuring device	251
6.3.5	Adaptation of the resolver evaluation dynamics	253
6.3.6	Parameterisation of an unknown Hiperface® encoder	254
6.3.7	Parameterisation of a Hiperface® encoder with increased initialisation time	254
6.3.8	Use of an SSI encoder at X8	255
6.3.9	Rotative encoder with SSI protocol	261
6.3.10	Provision of the encoder signal of input X8	263
6.3.11	Resolver error compensation	266
6.3.12	Encoder angular drift monitoring	267
<b>7</b>	<b>Braking operation</b>	269
7.1	Parameter setting	270
7.1.1	Setting the voltage threshold for braking operation	270
7.2	Monitoring	271
7.2.1	Overcurrent protection	271
7.2.2	Ixt utilisation - brake transistor	272
7.2.3	I2t utilisation - brake resistor	273
7.2.4	Overvoltage in the DC bus	275
<b>8</b>	<b>I/O terminals</b>	276
8.1	Overview	276
8.2	Analog inputs	277
8.2.1	Terminal assignment/electrical data	277
8.2.2	Parameter setting	278
8.2.3	Reconfiguring analog input 1 into current input	278
8.2.4	"LS_AnalogInput" system block	279
8.3	Analog outputs	280
8.3.1	Terminal assignment/electrical data	280
8.3.2	Parameter setting	281
8.3.3	"LS_AnalogOutput" system block	281
8.4	Digital inputs	282
8.4.1	Terminal assignment/electrical data	282
8.4.2	Parameter setting	282
8.4.3	"LS_DigitalInput" system block	283
8.5	Digital outputs	284
8.5.1	Terminal assignment/electrical data	284
8.5.2	Parameter setting	284
8.5.3	"LS_DigitalOutput" system block	285
8.6	"State bus" monitoring function	286
8.6.1	Detecting the current state	287
8.6.2	Setting the state bus to the "Error" state	287
8.7	Touch probe detection	288
8.7.1	Actual value interpolation (principle)	288
8.7.2	Dead time compensation	290
8.7.3	"LS_TouchProbe1...8" system block	291
8.7.4	"LS_TouchProbeMotor" system block	292
8.7.5	"LS_TouchProbeLoad" system block	292
8.8	Configure exception handling of the outputs	293

# Contents

---

<b>9</b>	<b>"CAN on board" system bus</b>	<b>295</b>
9.1	General information	296
9.1.1	General data and application conditions	297
9.1.2	Supported protocols	297
9.1.3	Communication time	298
9.2	Possible settings by DIP switch	299
9.2.1	Setting the node address	299
9.2.2	Setting the baud rate	300
9.3	LED status displays for the system bus	301
9.4	Structure of the CAN data telegram	302
9.4.1	Identifier	302
9.4.2	User data	304
9.5	Communication phases/network management	305
9.5.1	State transitions	306
9.5.2	Network management telegram (NMT)	307
9.5.3	Parameterising the controller as CAN master	308
9.6	Process data transfer	309
9.6.1	Identifiers of the process data objects	310
9.6.2	Transmission type	311
9.6.3	Masking of the TPDOs for event control	312
9.6.4	Monitoring of the RPDOs for data reception	312
9.6.5	Synchronisation of PDOs via sync telegram	313
9.7	Parameter data transfer	318
9.7.1	Identifiers of the parameter data objects	319
9.7.2	User data	319
9.7.3	Parameter data telegram examples	325
9.8	Diagnostics	330
9.9	Monitoring	331
9.9.1	Node guarding protocol	331
9.9.2	Heartbeat protocol	337
9.9.3	Emergency telegram	341
9.10	CANopen objects implemented	342
9.11	System block "LS_SyncInput"	367
9.11.1	Behaviour of the status signal bSyncnInsideWindow	368
<b>10</b>	<b>Safety engineering</b>	<b>369</b>
10.1	Integration into the application	370
10.2	Selecting the required safety module	371
10.3	System block "LS_SafetyModuleInterface"	371
10.3.1	Status information	373
10.3.2	I/O status information	374
10.3.3	Control information	374



# Contents

---

<b>11</b>	<b>Basic drive functions</b>	377
11.1	General information	378
11.1.1	Internal state machine	378
11.1.2	Function states	380
11.1.3	Interrupting/replacing states	382
11.1.4	Priorities	383
11.1.5	Requesting control via a basic function	384
11.1.6	Start acceleration/acceleration reduction when the basic function changes	385
11.1.7	Setting the S-ramp time	387
11.2	Stop	389
11.2.1	Internal interfaces   "LS_Stop" system block	390
11.2.2	Parameter setting	391
11.2.3	Behaviour of the function (example)	392
11.3	Quick stop	393
11.3.1	Internal interfaces   "LS_Quickstop" system block	393
11.3.2	Parameter setting	394
11.3.3	Activate/deactivate quick stop	396
11.3.4	DC-injection braking	397
11.4	Manual jog	400
11.4.1	Internal interfaces   "LS_ManualJog" system block	401
11.4.2	Parameter setting	404
11.4.3	Executing manual jogging	406
11.5	Manual job, encoderless	412
11.5.1	Parameter setting	413
11.5.2	Carrying out encoderless manual jogging	414
11.5.3	Internal interfaces   "LS_ManualJogOpenLoop" system block	419
11.6	Homing	421
11.6.1	Internal interfaces   "LS_Homing" system block	423
11.6.2	Parameter setting	425
11.6.3	Overview of the Lenze homing modes	432
11.6.4	Overview of DS402 homing modes	445
11.6.5	Execute homing	476
11.7	Positioning	479
11.7.1	Internal interfaces   "LS_Positioner" system block	480
11.7.2	Parameter setting	485
11.7.3	Carrying out positioning	487
11.8	Position follower	490
11.8.1	Internal interfaces   "LS_PositionFollower" system block	491
11.8.2	Signal flow	492
11.8.3	Parameter setting	493
11.8.4	Activating setpoint interface	495
11.9	Speed follower	496
11.9.1	Internal interfaces   "LS_SpeedFollower" system block	496
11.9.2	Signal flow	498
11.9.3	Parameter setting	499
11.9.4	Activating setpoint interface	500
11.10	Torque follower	501
11.10.1	Internal interfaces   "LS_TorqueFollower" system block	502
11.10.2	Signal flow	503
11.10.3	Parameter setting	504
11.10.4	Activating setpoint interface	505
11.11	Limiter	506
11.11.1	Internal interfaces   "LS_Limiter" system block	506
11.11.2	Parameter setting	511

# Contents

---

11.12 Brake control	521
11.12.1 Internal interfaces   "LS_Brake" system block	523
11.12.2 Parameter setting	526
11.12.3 Mode 0: Brake control is switched off	542
11.12.4 Mode 1/11: Direct control of the brake	543
11.12.5 Mode 2/12: Automatic control of the brake	544
11.12.6 Mode 22: Automatic DC-injection braking	549
11.12.7 Grinding the brake	552
11.12.8 Carrying out brake test	554
11.12.9 Control of two motor holding brakes	556
11.13 Cam data management	557
11.13.1 "Online" tab for cam data management	558
11.13.2 Internal interfaces   "LS_CamInterface" system block	563
11.13.3 Parameter setting	565
11.13.4 Product/track change-over	572
11.13.5 Invalid cam data due to changed machine parameters	573
11.13.6 Behaviour after mains switching	574
11.14 Pole position identification	575
11.14.1 Internal interfaces   System block "LS_PolePositionIdentification"	576
11.14.2 Parameter setting	578
11.14.3 Execution of the pole position identification	578
11.14.4 Signal characteristics	580
11.14.5 Deactivating a known pole position	582

# Contents

---

<b>12</b>	<b>Oscilloscope</b>	585
12.1	Functional description	586
12.2	Technical data	586
12.3	Operation	587
12.3.1	User interface	588
12.3.2	Selecting the signal sources to be recorded	590
12.3.3	Selecting the recording time/sample rate	592
12.3.4	Selecting the trigger condition	593
12.3.5	Start recording	595
12.3.6	Cyclic recording	595
12.3.7	Adjusting the representation	596
12.3.8	Cursor function: Reading individual measured values	598
12.3.9	Last settings	598
12.4	Managing oscillograms (measured data records)	599
12.4.1	Commenting the oscillogram	599
12.4.2	Saving the oscillogram in a file	600
12.4.3	Loading the oscillogram file	601
12.4.4	Importing settings from another loaded oscillogram	602
12.4.5	Overlay function	603
12.4.6	Deleting an oscillogram file saved in the project	604
12.5	Variables of the motor control (oscilloscope signals)	605

# Contents

---

<b>13</b>	<b>Diagnostics &amp; fault analysis</b>	608
13.1	LED status display	608
13.1.1	LED status displays for the device state	609
13.2	Drive diagnostics with the »Engineer«	610
13.3	Drive diagnostics via keypad/bus system	611
13.4	Logbook	613
13.4.1	Functional description	614
13.4.2	Filtering logbook entries	614
13.4.3	Reading out logbook entries	615
13.4.4	Exporting logbook entries to a file	616
13.5	Monitoring	617
13.5.1	Setting the error response	618
13.6	Maloperation of the drive	619
13.7	Error messages of the operating system	620
13.7.1	Structure of the error number (bit coding)	620
13.7.2	Reset error message	625
13.7.3	Short overview (A-Z)	626
13.7.4	Cause & possible remedies	634
<b>14</b>	<b>Parameter reference</b>	724
14.1	Structure of the parameter descriptions	725
14.1.1	Data type	725
14.1.2	Parameters with read-only access	725
14.1.3	Parameters with write access	726
14.1.4	Parameter attributes	730
14.1.5	Abbreviations used in parameter & selection texts	730
14.2	Parameter list	731
14.3	Table of attributes	927
	<b>Index</b>	942
	Your opinion is important to us	967

# 1 About this document

---

## 1 About this document



### Danger!

The Servo Drives 9400 HighLine are a source of danger which may cause death or serious personal injury.

In order to ensure protection against this danger, observe the safety instructions before switching on the Servo Drives 9400 HighLine.

Please read the safety instructions in the **mounting instructions** and **hardware manual** of the Servo Drives 9400 HighLine. Both instructions are included in the scope of supply.

### Target group

This documentation addresses to all persons who want to parameterise, configure, and diagnose the Servo Drives 9400 HighLine by means of the engineering software L-force »Engineer« and the keypad.

### Information regarding the validity

The information in this documentation are valid for the following standard devices:

Product range	Type designation	From software version
Servo Drives 9400	E94AxHExxx	1.5

### Screenshots/application examples

All screenshots in this documentation are application examples. Depending on the firmware version of the 9400 HighLine and the software version of the engineering tools installed (»Engineer« or »EASY Starter«), the screenshots in this documentation may differ from what actually appears on the screen.

# 1 About this document

---



## Document history

Version			Description
15.0	04/2019	TD06	New codes <a href="#">C02606</a> and <a href="#">C02872</a> , error corrections
12.0	07/2018	TD06	Extended oscilloscope functions, error corrections
11.0	11/2016	TD06	Extended oscilloscope functions, error corrections
10.0	11/2013	TD05	Error corrections; parameter reference V12.00.xx
9.0	12/2012	TD06	Extended by new functions for 9400 HighLine V11
8.0	12/2011	TD06	Extended by new functions for 9400 HighLine V10
7.1	10/2010	TD06	Error corrections & supplements
7.0	04/2010	TD06	Extended by new functions for 9400 HighLine V8
6.1	08/2009	TD05	Error corrections & supplements
6.0	08/2009	TD05	Extended by new functions for 9400 HighLine V7
5.2	01/2009	TD05	Error corrections & supplements
5.1	12/2008	TD05	Error corrections
5.0	11/2008	TD05	Extended by new functions for 9400 HighLine V5
4.1	07/2008	TD05	New main chapter: <a href="#">"CAN on board" system bus</a>
4.0	06/2008	TD05	Supplemented with new functions for 9400 HighLine V4
3.0	11/2007	TD05	Supplemented with new functions for 9400 HighLine V3
2.0	05/2007	TD05	Extended edition
1.0	12/2006	TD05	First edition for 9400 HighLine V1.5

# 1 About this document

## 1.1 Conventions used



This documentation uses the following conventions to distinguish between different types of information:

Type of information	Highlighting	Examples/notes
Numeric notation		
Decimal separator	Point	The decimal point is always used. For example: 1234.56
Text		
Version information	Blue text colour	All information applying to from a certain software version of Servo Drives 9400 HighLine is marked accordingly in this documentation. Example: <a href="#">This function extension is available from software version V3.0!</a>
Program name	» «	The Lenze PC software »PLC Designer«...
Window	<i>italics</i>	The <i>Message window...</i> / The dialog box <i>Options...</i>
Variable names		By setting <i>bEnable</i> to TRUE...
Control element	<b>Bold</b>	The <b>OK</b> button... / the <b>Copy</b> command... / the <b>Characteristics</b> tab... / the <b>Name</b> input field...
Sequence of menu commands		If several commands must be used in sequence to carry out a function, the individual commands are separated by an arrow: Select <b>File</b> → <b>Open</b> to...
Shortcut	< <b>bold</b> >	Use < <b>F1</b> > to open the online help. If a shortcut is required for a command to be executed, a "+" has been put between the key identifiers: With < <b>Shift</b> >+< <b>ESC</b> > ...
Program code	Courier	<pre>IF var1 &lt; var2 THEN   a = a + 1 END IF</pre>
Keyword	<b>Courier bold</b>	
Hyperlink	<u>Underlined</u>	Optically highlighted reference to another topic. It is activated with a mouse-click in this online documentation.
Symbols		
Page reference	 15	Optically highlighted reference to another page. It is activated with a mouse-click in this online documentation.
Step-by-step instructions		Step-by-step instructions are indicated by a pictograph.

# 1 About this document

## 1.2 Terminology used

### 1.2 Terminology used

Term	Meaning
Engineering Tools	Software solutions for easy engineering in all project stages
	 <ul style="list-style-type: none"> <li>»EASY Navigator« – ensures easy operator guidance</li> <li>• All convenient Lenze Engineering tools at a glance</li> <li>• Tools can be quickly selected</li> <li>• The clear structure simplifies the engineering process from the start</li> </ul>
	 <ul style="list-style-type: none"> <li>»EASY Starter« – easy-to-use tool for service technicians</li> <li>• Specifically designed for commissioning and maintaining Lenze devices</li> <li>• Graphic user interface with very few icons</li> <li>• Easy to run online diagnostics, set parameters and perform commissioning</li> <li>• No risk of accidentally changing an application</li> <li>• Loading off-the-shelf applications onto the device</li> </ul>
 <ul style="list-style-type: none"> <li>»Engineer« – multi-device engineering</li> <li>• For all products in our L-force portfolio</li> <li>• Practical user interface</li> <li>• Graphic interfaces make it easy to navigate</li> <li>• Can be applied in every phase of a project (project planning, commissioning, production)</li> <li>• Parameter setting and configuration</li> </ul>	
L-force Controller	The L-force Controller is the central component of the automation system which controls the Logic and Motion functionalities (by means of the runtime software). The L-force Controller uses the fieldbus to communicate with the field devices.
Engineering PC	The Engineering PC and the installed Engineering tools serve to configure and parameterise the system. The Engineering PC uses Ethernet to communicate with the L-force Controller.
Code	"Container" for one or several parameters by means of which you can parameterise or monitor Servo Drives 9400 HighLine.
Subcode	If a code contains several parameters, they are stored in "subcodes". This manual uses a slash "/" as a separator between code and subcode (e.g. "C00118/3").
Function block editor	Graphical interconnection tool which is provided for Servo Drives 9400 HighLine in the MotionControl HighLevel and TopLevel license level in the »Engineer« on the <b>FB editor</b> tab and by means of which the technology applications supplied can also be reconfigured and extended by individual functions.
Function block	A function block (FB) can be compared with an integrated circuit that contains a certain control logic and provides one or several values when being executed. <ul style="list-style-type: none"> <li>• An instance (reproduction, copy) of the function block is always inserted into the circuit.</li> <li>• It is also possible to insert several instances of a function block into a circuit.</li> <li>• Each instance has an unequivocal identifier (the instance name) and a processing number that defines the position in which the function block is calculated during the task cycle.</li> </ul>



# 1 About this document

## 1.3 Definition of the notes used

---

### 1.3 Definition of the notes used

The following signal words and symbols are used in this documentation to indicate dangers and important information:

#### Safety instructions

Structure of the safety instructions:



#### **Danger!**

(characterises the type and severity of danger)

#### **Note**

(describes the danger and gives information about how to prevent dangerous situations)

Pictograph	Signal word	Meaning
	<b>Danger!</b>	<b>Danger of personal injury through dangerous electrical voltage</b> Reference to an imminent danger that may result in death or serious personal injury if the corresponding measures are not taken.
	<b>Danger!</b>	<b>Danger of personal injury through a general source of danger</b> Reference to an imminent danger that may result in death or serious personal injury if the corresponding measures are not taken.
	<b>Stop!</b>	<b>Danger of damage to material assets</b> Reference to a possible danger that may result in the damage to material assets if the corresponding measures are not taken.

#### Application notes

Pictograph	Signal word	Meaning
	<b>Note!</b>	Important note to ensure trouble-free operation
	<b>Tip!</b>	Useful tip for easy handling
		Reference to another document

## 2 Introduction

### 2.1 Parameter setting, configuring, or programming?

---

## 2 Introduction

The basis of every **L-force** application is an easy and quick parameter setting of prepared technology applications and solutions\*.

This chapter contains basic information on the runtime software model of **L-force** and on how you can establish an online connection between the PC and controller for parameter setting with »Engineer« very easily.

At the end of this chapter you will find an overview of the different signal types & scaling which serve to process physical values (e.g. a speed or position) within the application.

\* In preparation!

### 2.1 Parameter setting, configuring, or programming?

The graded runtime software model of **L-force** provides a simple and consistent solution for motion and process tasks as well as for complex machine functions:

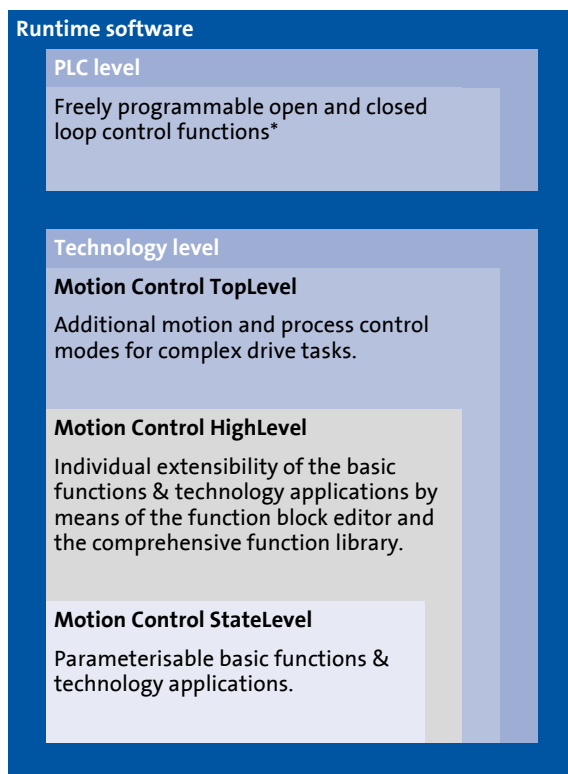

#### Programming\*

#### Configuration

The HighLevel and TopLevel licenses enable you to extend the provided technology applications by individual functions using the graphic function block editor of »Engineer«. Here you can access the comprehensive function libraries of Lenze which among other things contain process controllers, arithmetic functions, logic blocks, and ramp generators and integrators.

#### Parameter setting

The StateLevel license includes a range of technology applications which can be put into operation easily with a keypad or via dialogs in »Engineer«.

\* In preparation!

## 2 Introduction

### 2.1 Parameter setting, configuring, or programming?

#### 2.1.1 Basic functionalities

Important basic drive functions and further basic functions are implemented in the firmware of the controller and thus are always provided, irrespective of the runtime software licence available.

**Firmware**

<p><b>Motion Control basic drive functions</b></p> <ul style="list-style-type: none"><li>• <a href="#">Stop</a></li><li>• <a href="#">Quick stop</a></li><li>• <a href="#">Manual jog</a></li><li>• <a href="#">Homing</a></li><li>• <a href="#">Positioning</a></li><li>• <a href="#">Position follower</a></li><li>• <a href="#">Speed follower</a></li><li>• <a href="#">Torque follower</a></li><li>• <a href="#">Limiter</a></li><li>• <a href="#">Brake control</a></li></ul>	<p><b>Further basic functionalities</b></p> <ul style="list-style-type: none"><li>• <a href="#">Drive interface</a></li><li>• <a href="#">Motor interface</a></li><li>• <a href="#">Encoder evaluation</a></li><li>• <a href="#">I/O terminals</a></li><li>• <a href="#">Safety engineering</a></li><li>• <a href="#">Logbook</a></li><li>• <a href="#">Oscilloscope</a></li></ul>
---	--

#### 2.1.2 Technology applications

Technology applications (TAs) are applications prepared by Lenze which can serve as a basis for solving typical applications.

- The technology applications available for the Servo Drives 9400 can be selected in »Engineer« from the application catalogue.

**Runtime software**

**Technology level**

<p><b>Motion Control TopLevel</b></p> <ul style="list-style-type: none"><li>• TA "Positioning sequence control"</li><li>• TA "Electronic cam" *</li><li>• TA "Register control" *</li><li>• TA "Winding technology" *</li></ul>
<p><b>Motion Control HighLevel</b></p> <ul style="list-style-type: none"><li>• TA "Electronic gearbox"</li><li>• TA "Synchronism with mark synchronisation"</li></ul>
<p><b>Motion Control StateLevel</b></p> <ul style="list-style-type: none"><li>• TA "Actuator – speed"</li><li>• TA "Actuator – torque"</li><li>• TA "Table positioning"</li></ul>

Each higher license contains additional technology applications for further application fields.

\* In preparation!



#### Tip!

Detailed information about the individual technology applications can be found in the corresponding software manuals.

## 2 Introduction

### 2.2 Communicating with the controller

---

#### 2.2 Communicating with the controller

The following interfaces/communication modules can be used to establish communication between the PC and controller:

- Diagnostic interface X6/[Going online via diagnostic adapter](#)
- CAN on board interface/[Going online via system bus \(CAN on board\)](#) (23)
- Optional interfaces which are provided by corresponding communication modules in the module slots MXI1/MXI2 of the controller.



#### Note!

For communication with the controller, at least the control electronics of the controller must be supplied with 24 V low voltage via plug X2. For detailed information, please see the Mounting Instructions for the controller.



#### Stop!

If you change parameters in the »Engineer« while the controller is connected online, the changes will be directly accepted by the controller!



#### Tip!

Detailed information about the individual interfaces can be found in the corresponding Communication Manuals (KHB).

#### 2.2.1 Going online via diagnostic adapter

For initial commissioning of the controller you can for instance use the diagnostic adapter offered by Lenze:

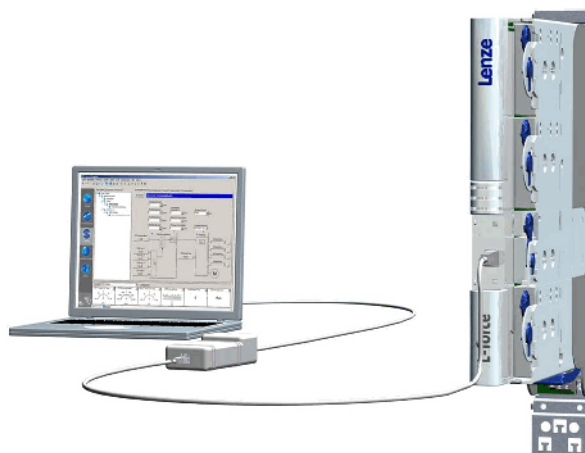

#### Note!

Please observe the documentation for the diagnostic adapter!

---

**Preconditions:**

- The diagnostic adapter is connected to the controller at the diagnostic interface X6 and to the PC at a free USB port.
- The driver required for the diagnostic adapter is installed.
- The control electronics of the controller is supplied with 24 V low voltage via plug X2.

**How to build up an online connection via the diagnostic adapter:**

1. Select the 9400 HighLine controller to which you want to build up an online connection in the *Project view* of the »Engineer«:

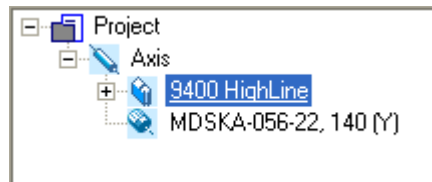

2. Click the  icon.

If the changes you have made on the project have not been accepted yet, first a query on whether an update is to be carried out is effected.

If an update is to be carried out:

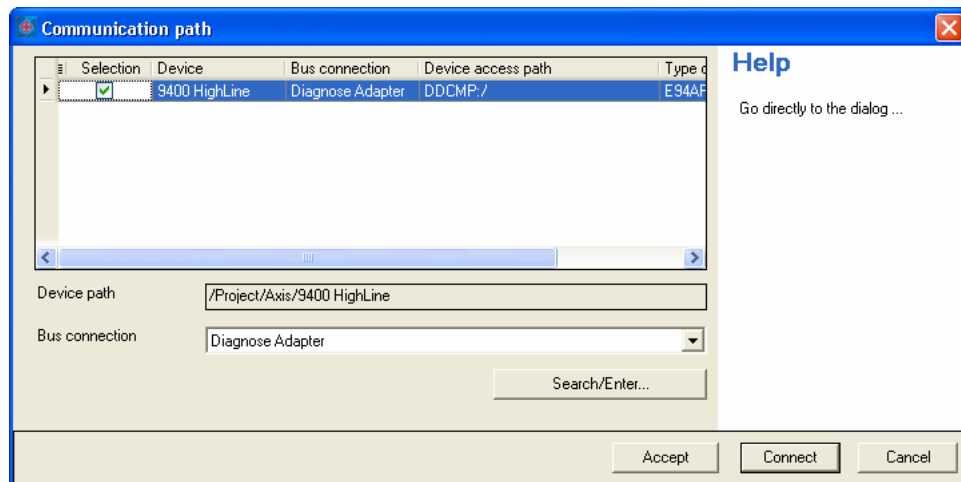

- Click **Yes** to open the *Build project* dialog box.
- Click **Build** in the *Build project* dialog box to update the changed project elements.
- After the update a note is shown, saying whether the update was carried out successfully.

If no communication path was configured yet for the controller selected, the *Communication path* dialog box is shown after the update has been carried out:

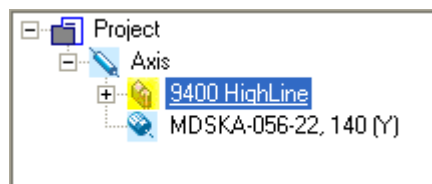

- The "Diagnostic adapter" bus connection is already preset.
3. Click on **Connect**.
    - The dialog box is closed and the online connection with the controller is built up.
    - In the *Project view* a yellow icon indicates the online connection with the controller:



Now you can use the icons  and  to easily build up and end a connection with the controller. The communication settings are only required when communication with a controller is built up for the first time.

- If you want to change the configured communication path, select the command **Online → Set communication path and go online** to open the *Communication path* dialog box and change the settings.
- When an online connection has been established, the »Engineer« displays the current parameter settings of the controller with a yellow background colour.

### 2.2.2 Going online via system bus (CAN on board)

As an alternative to the diagnostic adapter, you can use the integrated system bus interface (CAN on board, terminal X1) of the controller for communication.

- Lenze offers the following communication accessories for connection to the PC:

Communication accessories	PC interface
<b>PC system bus adapter 2173</b> incl. connection cable and voltage supply adapter <ul style="list-style-type: none"> <li>• for DIN keyboard connection (EMF2173IB)</li> <li>• for PS/2 keyboard connection (EMF2173IBV002)</li> <li>• for PS/2 keyboard connection with electrical isolation (EMF2173IBV003)</li> </ul>	Parallel interface (LPT port)
<b>PC system bus adapter 2177</b> incl. connection cable (EMF2177IB)	USB (Universal Serial Bus)



#### Note!

- For detailed information about the PC system bus adapter, please see the "CAN Communication Manual".
- Please observe the documentation for the PC system bus adapter!
- The online connection is established as described in the previous chapter "[Going online via diagnostic adapter](#)", only that this time the entry "CAN system bus" is to be selected in the **Bus connection** list field of the *Communication path* dialog box. (📖 21)

### 2.2.3 Use of other communication interfaces

The controller can be extended by further communication interfaces, if required, e.g. Ethernet, ETHERNET Powerlink, or PROFIBUS.

- For this the controller is provided with the module slots MXI1 and MXI2 for accepting communication modules.
- Detailed information on this subject can be found in the Hardware Manual and Communication Manual for the corresponding communication system.

## 2.3 Signal types & scaling

It is very helpful for the parameterisation & configuration of the controller to know the signal types and their scaling listed below, which serve to process physical quantities (e.g. a speed or position) within the function block interconnection.



### Note!

From software version V3.0 the resolution of an encoder revolution can be parameterised in [C00100](#) (Lenze setting: 16 bits/encoder revolution).

▶ [Resolution of an encoder revolution](#) (40)

Signal type (data type)	Connection symbol in the FB editor	Resolution	Value range (external)	Decimal positions/ signal type suffix in the identifier	
Scaled (INT)	○	16 bits	± 199.99 %	2	_a
Scaled (DINT)	●	32 bits	± 200.00 %	2	_n
Speed (INT)	◁/▷	16 bits	± 30000.0 rpm	1	_v
Speed (DINT)	◆	32 bits	± 480000.0 rpm	1	_s
Position/angle (DINT)	◁/▷	32 bits	-2 <sup>31</sup> ... 2 <sup>31</sup> -1 increments	3	_p
Digital (BOOL)	□	1 bit	0 ≡ FALSE; 1 ≡ TRUE	0	
Acceleration (DINT)	■	32 bits	± 7.69 * 10 <sup>9</sup> rpm/s	3	_x
Time	■	28 bits	0 ... 268435.456 s	3	
Other (BYTE)	■	8 bits	0 ... 255	0	
Other (WORD)	■	16 bits	0 ... 65535	0	
Other (DWORD)	■	32 bits	0 ... 4294967295	0	
Other (INT)	■	16 bits	-32768 ... 32767	0	
Other (DINT)	■	32 bits	-2147483648 ... 2147483647	0	

### Scaling of physical units

Signal type	Connection symbol in the FB editor	Resolution	Standardisation	
			External value	≡ internal value
Scaled (INT)	○	16 bits	100 %	≡ 2 <sup>14</sup> ≡ 16384
Scaled (DINT)	●	32 bits	100 %	≡ 2 <sup>30</sup> ≡ 1073741824
Speed (INT)	◁/▷	16 bits	15000 rpm	≡ 2 <sup>14</sup> ≡ 16384
Speed (DINT)	◆	32 bits	15000 rpm	≡ 2 <sup>26</sup> ≡ 67108864
Position/angle (DINT)	◁/▷	32 bits	1 encoder revolution	≡ 2 <sup>16</sup> increments
Acceleration (DINT)	■	32 bits	15000000 rpm/s	≡ 2 <sup>22</sup> ≡ 4194304



### 3 Commissioning

This documentation contains detailed information on parameter setting and configuration of the controller. Sequential reading is not required.

In order to obtain the information relevant for initial commissioning, this chapter describes different commissioning scenarios which can also be used as a guide through this manual:

A. [Initial commissioning](#) (📖 28)

- **Target:** Adapting the controller to the electromechanics and the control system.

B. [Standard set-up](#) (📖 29)

- **Target:** Taking over the application and parameter set of an already preconfigured "Engineer" project into several controllers.

C. [Controller replacement](#) (📖 30)

- **Target:** Replacing a controller which has failed in a running system by a replacement device using the "old" memory module.

D. [Motor replacement](#) (📖 30)

- **Target:** Replacing a motor which has failed in a running system.

# 3 Commissioning

## 3.1 General notes

---

### 3.1 General notes



#### Note!

Some parameters of the controller have a setting range depending on the device type. If parameterisation is carried out offline or if the memory module is exchanged between different 9400 HighLine device types, always check the settings of the parameters listed in the following table and adapt them, if required, to prevent a parameter error after the parameter set download or module change!

Parameters	Info	Lenze setting
<a href="#">C00018</a>	<a href="#">Switching frequency</a>	8 kHz variable
<a href="#">C00022</a>	Maximum current ▶ <a href="#">Accepting/adapting plant parameters</a> (📖 127)	0.00 A
<a href="#">C00173</a> <a href="#">C00174</a>	Mains voltage and undervoltage threshold (LU) ▶ <a href="#">Machine parameters</a> (📖 32)	400/415 V, LU = 285 V



#### Tip!

The rated data of the different device types can be found in the Hardware Manual in the "Rated data" chapter.

#### Term definition of "Plant parameters"

The term "plant parameters" which is frequently used in the following chapters summarises all parameters which result from the combination of motor and load. They characterise the transfer behaviour of the entire controlled system including the desired monitoring functions. The plant parameters depend on the application in which the controller and motor are used.

### 3.2 Notes on commissioning using the keypad

#### For a motor with an electronic nameplate (ENP)

- A display of the plant parameters offered by ENP via keypad is not provided. The plant parameters must be edited and optimised individually.
- To avoid that the motor starts unintentionally without adjusting the plant parameters, the maximum current in the Lenze setting is set to "0 A" in [C00022](#).
- After setting the plant parameters, they have to be saved on the memory module of the controller with mains failure protection, just as the motor data that have been read out from the ENP ([C00002](#) = "11: Save start parameters").

#### For a motor without an electronic nameplate (ENP)

- The motor data and plant parameters must be edited and set individually.
- To avoid that the motor starts unintentionally without adjusting the plant parameters, the maximum current is set to "0 A" in [C00022](#) by the factory.
- After setting the motor data and plant parameters, they have to be saved on the memory module of the controller with mains failure protection ([C00002](#) = "11: Save start parameters").

#### Commissioning of the application

- The application must already be stored on the memory module of the controller. Otherwise commissioning by only using the keypad is not possible.
- All application parameters which deviate from the factory adjustment have to be edited individually. For this the project planner has to provide a corresponding list to the commissioner (including the motor and plant data).
- In the case of a standard set-up, a pole position identification may have to be carried out for synchronous motors of a third party manufacturer or Lenze synchronous motors with a Stegmann absolute value encoder.
- After setting the parameters, they have to be saved on the memory module of the controller with mains failure protection ([C00002](#) = "11: Save start parameters").



#### Tip!

Detailed information on the individual technology applications can be found in the corresponding Software Manual for the technology application and the »Engineer« online help in the chapter "L-force Servo Drives 9400 → Technology applications".

# 3 Commissioning

## 3.3 Initial commissioning

### 3.3 Initial commissioning

Worksteps	
<b>Parameterising motor control:</b>	
1	Read out the motor data of the controller or select them via the »Engineer« motor catalogue. <ul style="list-style-type: none"><li>• If the motor connected to the controller is provided with an electronic nameplate (ENP), all motor data are automatically read out from the ENP and a selection in the motor catalogue is not required. ▶ <a href="#">Reading out motor data from the controller</a> (☞ 120)</li><li>• If a motor without ENP or a motor by a third-party manufacturer is used, the selection is carried out via the »Engineer« motor catalogue. ▶ <a href="#">Selecting a motor from the motor catalogue in the »Engineer«</a> (☞ 121)</li></ul>
2.	<a href="#">Select motor control.</a> (☞ 124) <ul style="list-style-type: none"><li>• Servo control is preset for the synchronous motor.</li></ul>
3	<a href="#">Adjusting motor and controller to each other</a> (☞ 126)
4	Carry out settings for selected motor control. <ul style="list-style-type: none"><li>• For this see description for the corresponding motor control:<ul style="list-style-type: none"><li>• <a href="#">Servo control (SC)</a></li><li>• <a href="#">Sensorless vector control (SLVC)</a> (from software version V3.0)</li><li>• <a href="#">V/f control (VFCplus)</a> (from software version V3.0)</li><li>• <a href="#">V/f control (VFCplus)</a> (from software version V3.0)</li></ul></li></ul>
<b>Parameterise/configure application:</b>	
5	Load & parameterise technology application.
	Detailed information on the individual technology applications can be found in the corresponding Software Manual for the technology application and the »Engineer« online help in the chapter "L-force Servo Drives 9400 → Technology applications".
6	If required, reconfigure the interconnection of the technology application with the function block editor.
<b>Optimise control mode:</b>	
7	Optimise control mode of the selected motor control. <ul style="list-style-type: none"><li>• By means of traversing profile from the application and oscilloscope.</li><li>• For this see description for the corresponding motor control:<ul style="list-style-type: none"><li>• <a href="#">Servo control (SC)</a></li><li>• <a href="#">Sensorless vector control (SLVC)</a> (from software version V3.0)</li><li>• <a href="#">V/f control (VFCplus)</a> (from software version V3.0)</li><li>• <a href="#">V/f control (VFCplus)</a> (from software version V3.0)</li></ul></li></ul>
<b>Save project and parameter set:</b>	
8	Execute device command <a href="#">C00002</a> = "11: Save start parameters".
9	Save »Engineer« project.

#### More (optional) worksteps

Worksteps	
<b>Establish network:</b>	
1	Insert network and machine application into the »Engineer« project.
2.	Interconnect port blocks reasonably to each other within the machine application.
3	Configure network (set addresses, baud rate, and process data channels in a reasonable manner).
4	Establish communication with the control system.
5	Establish communication with other drive components (e.g. HMIs, I/O extensions and other controllers).

Worksteps	
<b>Check &amp; optimise application/DC-bus operation:</b>	
1	Traverse axis in manual operation. • See chap. <a href="#">Basic drive functions</a> ▶ <a href="#">Manual jog</a> (📖 400)
2.	Check area boundaries (path, speed, torque).
3	Traverse axis in automatic operation with set-up speed, possibly together with coupled axes.
4	Check coupling with other movements (master/slave axes, tools, ...).
5	Optimisation of the process at higher speeds.
6	Recording of typical signal characteristics using the oscilloscope function for the documentation. • See chapter <a href="#">Oscilloscope</a> (📖 585)
<b>Save &amp; archive project and parameter set:</b>	
1	Execute device command <a href="#">C00002</a> = "11: Save start parameters".
2.	Save »Engineer« project.
3	Deposit a backup copy of the »Engineer« project, e.g. on CD ROM, in the control cabinet.

## 3.4

## Standard set-up

Worksteps	
<b>Transfer application and parameter set to the controller:</b>	
1	Transfer the application preconfigured in »Engineer« and the corresponding parameter set to the memory module of the controller.
2.	Execute device command <a href="#">C00002</a> = "11: Save start parameters".
<b>For a motor with an electronic nameplate (ENP):</b>	
3	Restart controller with connected motor to read out the motor data from the electronic nameplate (ENP). • Either by switching off/switching on again the voltage supply or by means of device command <a href="#">C00002</a> = "11000: Restart controller". • See chap. <a href="#">Motor interface</a> ▶ <a href="#">Reading out motor data from the controller</a> (📖 120)
4	Execute device command <a href="#">C00002</a> = "11: Save start parameters".
<b>For a motor without an electronic nameplate (ENP):</b>	
	<b>Note:</b> The motor is operated with the motor data and plant parameters identified during initial commissioning. ▶ <a href="#">Adjusting motor and controller to each other</a> (📖 126)

### 3.5 Controller replacement

Scenario: The controller has failed in a running system.



#### Note!

For the procedure described in the following it is assumed that the memory module and possibly available extension modules in the controller, as well as the motor are not affected by the failure and that all parameters have been saved with mains failure protection.

Worksteps	
<b>Replacement of the controller:</b>	
1	Replace controller. <b>See Mounting Instructions for the controller!</b>
2.	Insert the memory module of the failed controller into the replacement device.
3	If further extension modules are plugged into the failed controller, they must be inserted into the replacement device as well.
Further steps are not required since all data required are on the memory module.	

### 3.6 Motor replacement

Scenario: The motor has failed in a running system.



#### Note!

For the procedure described in the following it is assumed that the controller is not affected by the failure.

Worksteps	
<b>Replacement of the motor:</b>	
1	Replace the motor. <b>See Mounting Instructions for the controller!</b>
	<b>Note:</b> The motor connection on the controller is accessible without having to remove the standard device from the installation backplane.
<b>For a motor with an electronic nameplate (ENP):</b>	
2.	Restart controller with connected motor to read out the motor data from the electronic nameplate. <ul style="list-style-type: none"> <li>• Either by switching off/switching on again the voltage supply or by means of device command <a href="#">C00002</a> = "11000: Restart controller".</li> <li>• See chap. <a href="#">Motor interface</a> ▶ <a href="#">Reading out motor data from the controller</a> (□ 120)</li> </ul>
3	Execute device command <a href="#">C00002</a> = "11: Save start parameters".
<b>For a motor without an electronic nameplate (ENP):</b>	
	<b>Note:</b> The motor is operated with the motor data and plant data from the memory module.

## 4 Drive interface

This chapter provides you with information on the drive interface via which you can control the drive controller into specific states and call different pieces of status information of the controller. Furthermore the machine constants for the motor end are entered via the drive interface.



### How to get to the dialog for setting the drive interface parameters:

1. Go to the *Project view* of the »Engineer« and select the 9400 HighLine controller.
2. Select the **Application parameters** tab from the *Workspace*.
3. Click the following button of the *Overview* dialog level:



### Parameterisation dialog in the »Engineer«

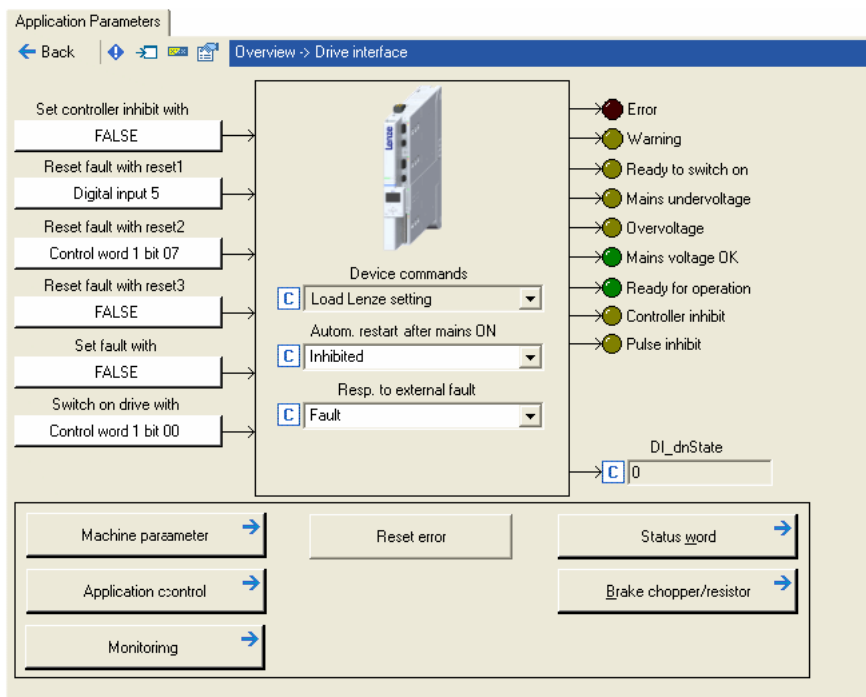

- The white buttons indicate the configuration of the drive interface inputs. ▶ [Internal interfaces](#) | ["LS\\_DriveInterface" system block \(113\)](#)
  - The assignment is predefined by the technology application selected (in the example "Actuating drive – speed"). If required, this assignment configuration can be changed by clicking the corresponding buttons.
- If you click a button marked with the → symbol, you go one level deeper in the corresponding parameterisation dialog.

# 4 Drive interface

## 4.1 Machine parameters

### 4.1 Machine parameters

The global machine constants ("machine parameters") are set in the »Engineer« on the **Application parameters** tab in the dialog level *Overview* → *Drive interface* → *Machine parameters*:

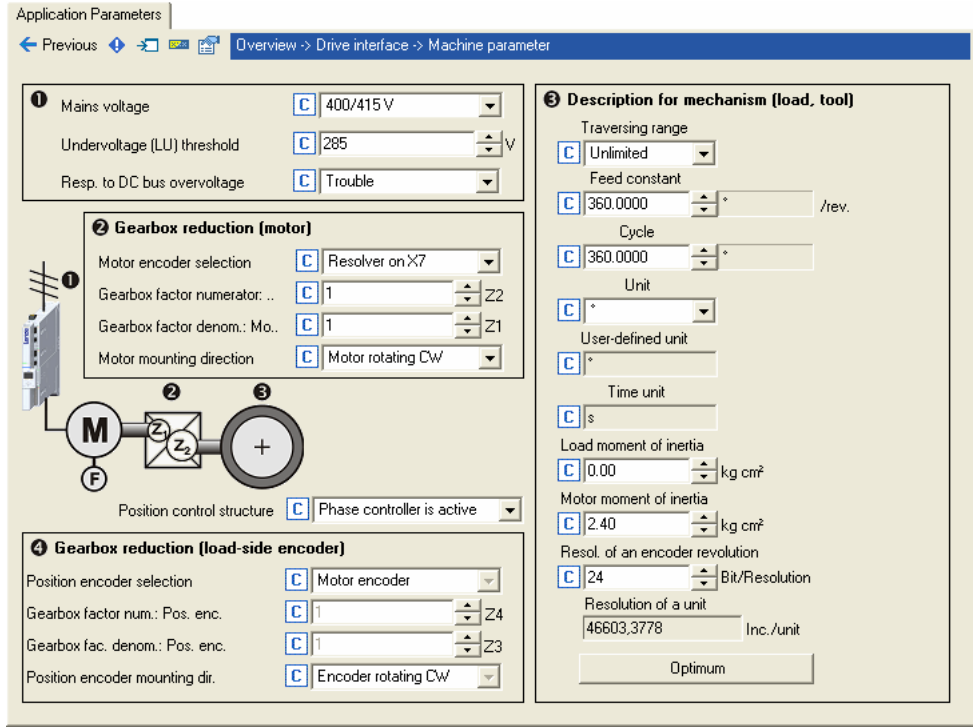

#### Tip!

Detailed information on the different machine parameters can be obtained from the following subchapters.



# 4 Drive interface

## 4.1 Machine parameters

---

### 4.1.1 Mains voltage

Via the **Mains voltage** list field ([C00173](#)) the mains voltage for the controller is set.

- If you set a mains voltage with an adjustable threshold for undervoltage ("LU adjustable"), this undervoltage threshold can be set in the **Undervoltage threshold (LU)** input field ([C00174](#)).
- In the **Resp. to DC-bus overvoltage** list field ([C00600](#)) you can select the response that is to be effected when a DC-bus overvoltage occurs.



#### Note!

Changing the setting in [C00173](#) also affects the permissible device utilisation!



#### Tip!

In the chapter "Rated data" of the hardware manual the device types and their permissible device utilisation at a certain mains voltage and switching frequency are specified.

*See also:* [▶ Monitoring of the device utilisation](#) (📖 111)

# 4 Drive interface

## 4.1 Machine parameters

### 4.1.2 Gearbox ratio

The gearbox ratio indicates the number of revolutions of the motor axis it takes for exactly one revolution of the load axis (e.g. spindle or drive roll) to take place.

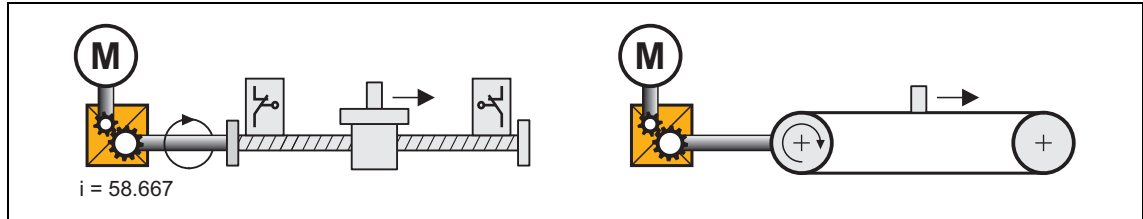

[4-1] Schematic diagram of gearbox ratio

- In the example shown in illustration [4-1] one revolution of the spindle is carried out at exactly 58,667 revolutions of the motor axis.

#### Specification of the gearbox ratio

- The gearbox ratio is to be defined in the form of a quotient (numerator/denominator); the data required can be found in the technical data for the gearbox:

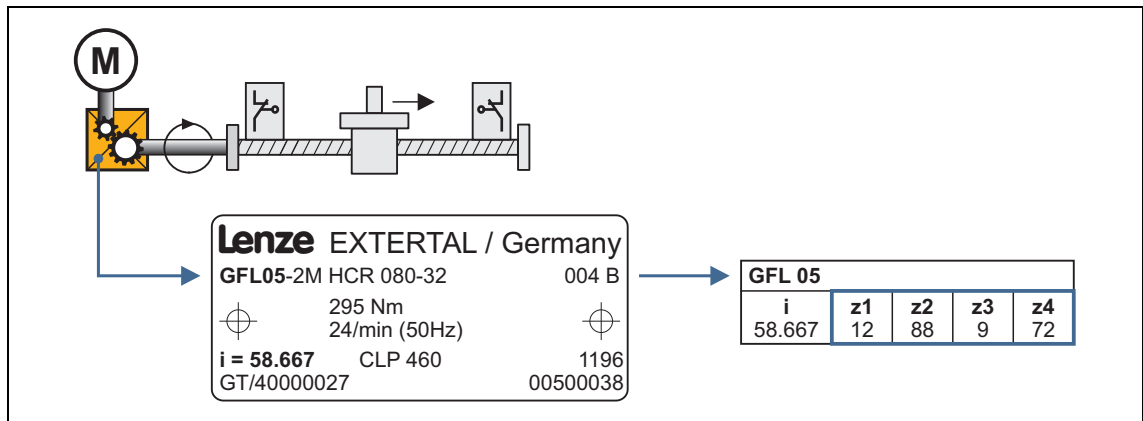

[4-2] Example: Technical data relating to the gearbox (from gearbox catalogue)



#### Tip!

In order to specify the gearbox ratio exactly, use the number of teeth indicated on the data sheet or in the catalogue, if possible, instead of the information on the nameplate (see following calculation).

In [C02531/1](#) the gearbox factor is displayed in decimal format.

#### Example calculation on the basis of the technical gearbox data:

$$\begin{aligned} \text{Gearbox factor numerator (C02520)} &= z2 \times z4 = 88 \times 72 = 6336 \\ \text{Gearbox factor denominator (C02521)} &= z1 \times z3 = 12 \times 9 = 108 \end{aligned}$$

[4-3] Sample calculation

## 4 Drive interface

### 4.1 Machine parameters

---

#### 4.1.3 Motor mounting direction

Depending on the motor mounting position, you can carry out an inversion of the direction of rotation via the **Motor mounting direction** list field ([C02527](#)), if required:

- [C02527](#) = "0": Clockwise rotating motor  $\equiv$  positive machine direction.
- [C02527](#) = "1": Counter-clockwise rotating motor  $\equiv$  positive machine direction.

#### 4.1.4 Feedback configuration

In most cases the system only has one motor encoder, i.e. no separate position encoder is installed on the load side. The motor position (angle of rotation) and motor speed are detected via the motor encoder selected in [C00495](#) and converted with regard to the load side.

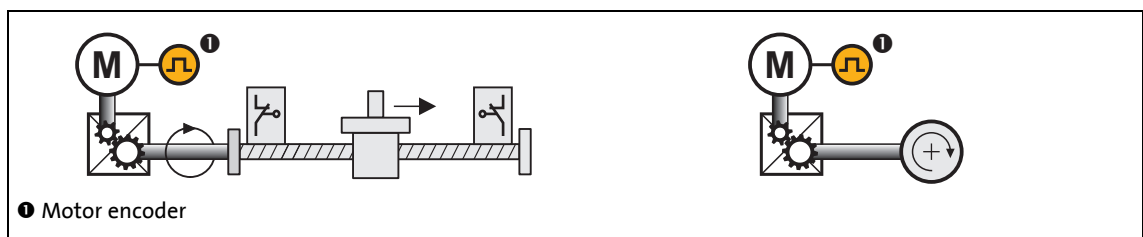

[4-4] Schematic diagram - feedback with position encoder = motor encoder

The actual position and speed values on the machine side result from the conversion via the [Gearbox ratio](#) on the motor side and the [Feed constant](#).



#### Tip!

Detailed information on the parameterisation of the feedback systems for the motor control can be found in the chapter "[Encoder evaluation](#)". ([239](#))

# 4 Drive interface

## 4.1 Machine parameters

---

### 4.1.5 Unit/user-defined unit

Via these machine parameters you define the real unit of the machine in which the feed constant and the parameters for a travel profile must be specified (e.g. position, speed, acceleration, and deceleration).

- If you for instance set the unit "mm" for a linear axis, the position must be specified in [mm] and the speed in [mm/s].
- By means of the user-defined unit, significant production units, like for example "bottles" can also be set.
  - For this, select the "User-defined" entry as unit in [C02525](#) and then enter the desired user-defined unit in [C02526](#).



#### Note!

In this documentation the term "unit" in the parameter unit data only serves as a wildcard for the real unit of the machine.

#### Display parameter

Parameters	Info
<a href="#">C02534</a>	Time unit used
<a href="#">C02535</a>	Unit used
<a href="#">C02537</a>	Speed unit
<a href="#">C02538</a>	Acceleration unit

Greyed out = display parameter

### 4.1.6 Traversing range

The selection of the traversing range ("Unlimited", "Limited", or "Modulo") in the **Traversing range** list field ([C02528](#)) serves to define the machine measuring system.



#### Note!

A change-over of the traversing range results in a loss of the reference information!

#### "Unlimited" traversing range

The drive can rotate continuously in one direction.

- By referencing and activating the software limit positions the traversing range can be limited.
- For positioning with absolute travel command the home position must be known.

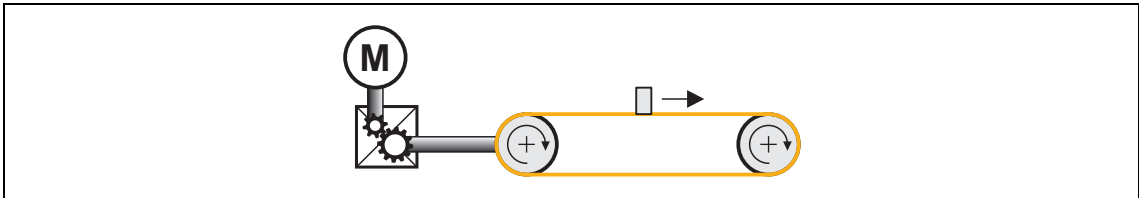

[4-5] Unlimited traversing range, taking the "feed control tape" as an example

#### "Limited" traversing range

The travel range is limited by positive and negative position limits (mechanical limits/travel range limit switches/software limit positions). ▶ [Limitier](#) (📖 506)

- After a defined distance the drive must travel in the opposite direction again.
- For positioning in the limited traversing range the home position must be known.
- The software limit positions are basically monitored with regard to the maximum value range that can be represented internally ( $\pm 2^{31}$  increments), even if monitoring has been deactivated via [C02700](#).
- An overflow of the value range results in a loss of the reference information.

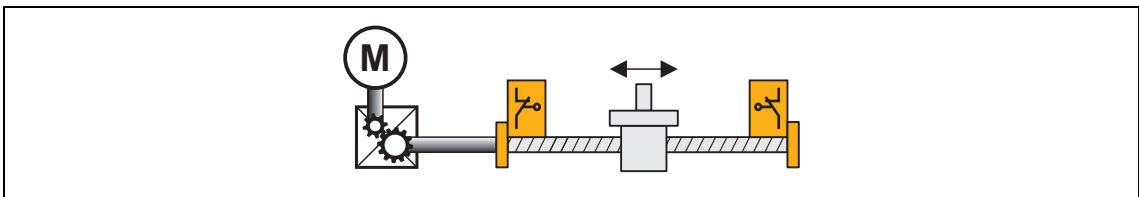

[4-6] Example: Limited traversing range - "spindle drive" (linear axis)

# 4 Drive interface

## 4.1 Machine parameters

### "Modulo" traversing range

The measuring system is repeated.

- If the cycle set in [C02536](#) is exceeded, a defined overflow occurs. In a rotative system, the cycle typically corresponds to a revolution or tool distance.
- For positioning in the "Modulo" traversing range the home position must be known.
- Software limit positions are not effective.
- Absolute targets can be approached by exceeding the measuring system limit, e.g. from 10° to 350°.

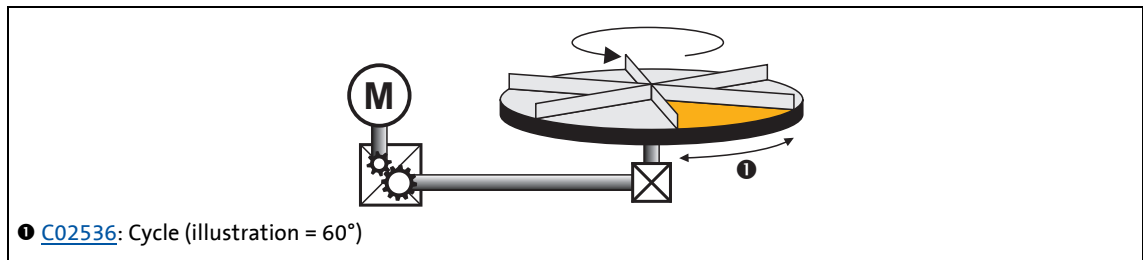

[4-7] Example: Modulo traversing range - "rotary table"

### Dependencies - traversing range/basic drive functions

- The following table lists the different dependencies between the selected traversing range and the basic drive functions.

Basic drive function	Traversing range		
	Unlimited	Limited	Modulo
Position data for <a href="#">Encoder evaluation</a>	Continuously	Continuously	Clocked
Position data for <a href="#">Position follower</a>	Absolute	Absolute	Absolute (in time)
Positioning modes for <a href="#">Positioning</a>	1, 2, 5, 6, 7, 8	1, 2, 5, 6, 7, 8	5, 6, 11 ... 16
Restrictions for <a href="#">Homing</a>	None	None	Home position must be in time
Limit positions ( <a href="#">Limiter</a> )	Permitted	Permitted	Not permitted

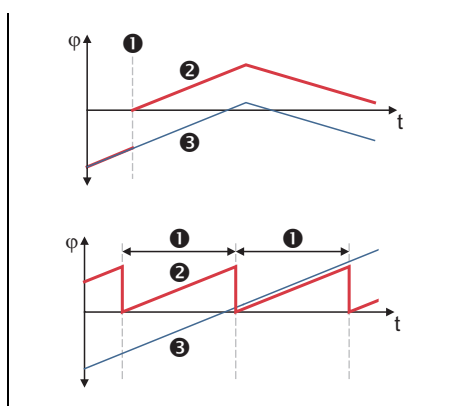

Example 1: Unlimited/limited position display

- ① Reference setting
- ② Position in the machine measuring system
- ③ Position in the motor measuring system

Example 2: Modulo position display

- ① Cycle
- ② Position in the machine measuring system
- ③ Position in the motor measuring system

# 4 Drive interface

## 4.1 Machine parameters

### 4.1.7 Feed constant

The feed constant corresponds to the movement of the machine during one revolution of the gearbox output shaft.

- The entry in the **Feed constant** field ([C02524](#)) is made in the unit defined in [C02525](#) relating to one revolution.
- In the case of a conveyor drive, the feed constant is obtained from the drive roll's circumference, which, in the following example, is calculated on the basis of the indicated diameter:

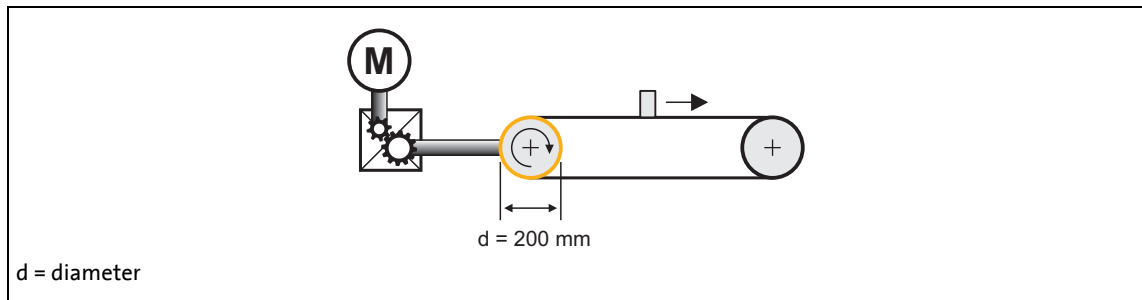

$$\text{Feed constant} = \pi \cdot d \frac{[\text{Unit}]}{\text{Revolution}} = \pi \cdot 200 \frac{\text{mm}}{\text{Revolution}} = 628.3185 \frac{\text{mm}}{\text{Revolution}}$$

[4-8] Schematic diagram: Feed constant for a conveyor driver

- In the case of a spindle drive (linear axis), the feed constant is derived from the leadscrew pitch. The feed constant indicates the distance the slide travels during one revolution of the spindle (in the following example: 5.023 mm).

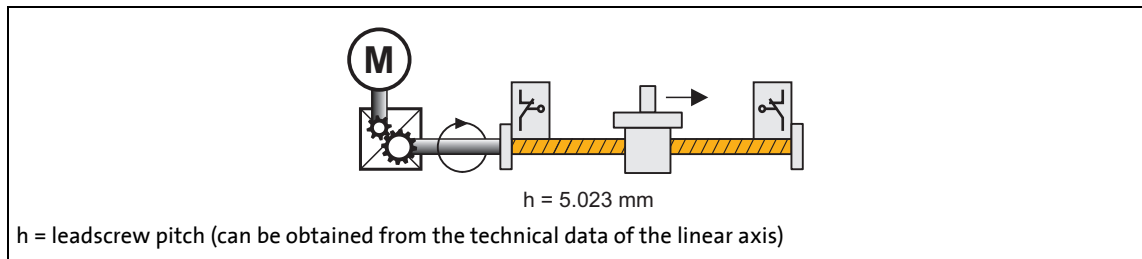

[4-9] Schematic diagram: Feed constant for a spindle drive

- In the case of a rotary table and its specification as an angle, the feed constant is = 360°/revolution.

# 4 Drive interface

## 4.1 Machine parameters

### 4.1.8 Resolution of an encoder revolution

The following applies to software versions lower than V3.0:

The resolution of an encoder revolution and hence of a position value is constantly set to 16 bits/revolution, which corresponds to 65536 increments/revolution. At this resolution, the traversing range comprises  $\pm 32767$  revolutions.

The following applies from software version V3.0:

[C00100](#) serves to adjust the resolution to the application.

- The default resolution of 16 bits/revolution is sufficient for standard applications.

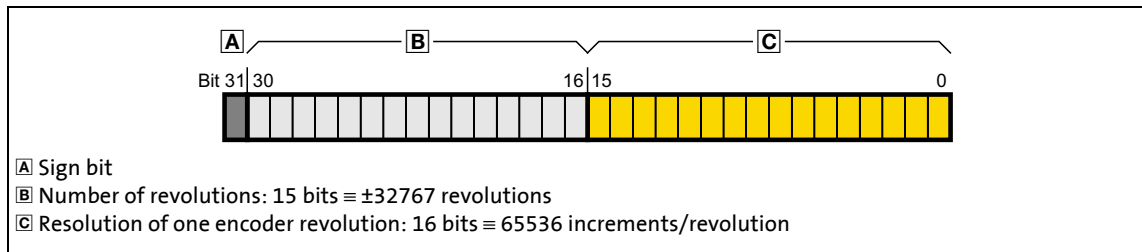

[4-10] Example: standard resolution (16 bits/revolution)

- For more significant applications, a higher resolution of the position values can clearly improve the control properties and positioning accuracies:
  - Finer resolution of the position targets  $\rightarrow$  improved positioning accuracy
  - Finer quantisation of setpoints and actual values  $\rightarrow$  better control quality
  - Higher loop gain adjustable  $\rightarrow$  less following errors
- However, a higher resolution at the same time causes a restricted number of encoder revolutions, and only smaller traversing distances can be displayed.

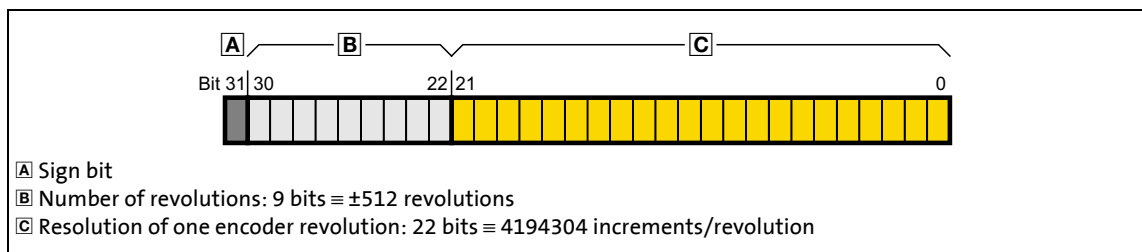

[4-11] Example: Higher resolution (22 bits/revolution) with a restricted traversing range



#### Tip!

In the following subchapter "[Determining the optimum resolution](#)" (42) it is described how you can determine the optimum resolution of the position values.



**Note!**

The position values (e.g. setpoints, actual values, parameters, ...) in the signal flow always use the resolution set in [C00100](#). In this connection it is irrelevant which resolution is delivered directly by the encoder.

**Multi-axis systems**

In an interconnection via the electrical shaft, at least two measuring systems (master and slave) are available in the drive.

- Each measuring system is provided with an individual setting of the resolution.
- The machine parameters (gearbox factors, feed constants, encoder resolution and cycle) for the master measuring system or master value must be set identically for all drives in the system.

**Technology applications "Electronic gearbox" and "Synchronism"**

For these two technology applications the machine parameters of the master measuring system are defined on the *Application parameters* tab in the "Master value scaling" dialog level.

**Electronic cam**

The machine parameters of the master measuring system for electronic cams can be defined on the *Measuring systems* tab for the electrical shaft.

## 4.1.8.1 Determining the optimum resolution

This function extension is available from software version V3.0!



#### How to determine the optimum resolution:

In the dialog level *Overview* → *Drive interface* → *Machine parameters*:

1. Set gearbox factors.
2. Set real unit of the machine.
3. Set feed constant.
4. Click the **Optimum positional resolution** button.
  - The *Optimum positional resolution* dialog box is displayed:

5. Go to the **Max. presentable position** input field and enter the highest position which is to be entered in a parameter during operation.
  - If required, set a reserve in the **Overshoot** input field to take into account possible following errors (overshoot of actual values).

Then the maximum resolution for the position entered is shown in the **Maximum resolution for encoder revolution** field.

6. Click **Accept value** to accept the displayed resolution in [C00100](#).
7. Click **Close** to close the dialog box again.



#### Tip!

In order to display the position that can be maximally represented for a defined resolution, activate the second option **Determine max. presentable position**. Then you can set the resolution for which the maximally presentable position is to be displayed in the **Maximum resolution for encoder revolution** input field.

# 4 Drive interface

## 4.1 Machine parameters

---

### 4.1.9 Max. position, speed, and acceleration that can be displayed internally

By setting the following machine parameters, the connection between the real units (application units) of the machine and the internal units in the controller is described:

- Gearbox ratio ([C02520](#), [C02521](#), [C02522](#), [C02523](#))
- Feed constant ([C02524](#))
- Resolution of an encoder revolution ([C00100](#))

Possibly the defined values for position, speed, and acceleration cannot be represented in the internal units by the numerical 32-bit format used.

- The following display parameters show the values that can be maximally displayed:

Parameters	Info	Lenze setting	
		Value	Unit
<a href="#">C02539</a>	Maximum position that can be displayed	-	Unit
<a href="#">C02540</a>	Speed that can be maximally displayed	-	Unit/s
<a href="#">C02541</a>	Acceleration that can be maximally displayed	-	Unit/s <sup>2</sup>

Greyed out = display parameter

#### Response if a value that cannot be displayed internally is entered

If a position, speed, or acceleration which cannot be represented internally is defined via parameters, the value defined is limited to the maximum value that can be represented internally ( $\pm 2147483647$ ).

The following only applies to software version V3.0:

- If a position, speed, or acceleration which cannot be represented internally is defined via parameters, the value defined is rejected.
- If an internal counter overflow of a parameter value due to a subsequent change of the machine parameters for the gearbox ratio, feed constant, or resolution of an encoder revolution is detected, the "Fault" error response is triggered and a corresponding error message is entered in the logbook of the controller:

Error number	Error message
0x00B8001A	Int. overflow <a href="#">C02620</a> (manual speed 1)
0x00B8001B	Int. overflow <a href="#">C02621</a> (manual speed 2)
0x00B8001C	Int. overflow <a href="#">C02622</a> (manual acceleration)
0x00B8001D	Int. overflow <a href="#">C02624</a> (manual deceleration)
0x00B80020	Int. overflow <a href="#">C02701/1</a> (positive SW limit position)
0x00B80021	Int. overflow <a href="#">C02701/2</a> (negative SW limit position)
0x00B80022	Int. overflow <a href="#">C02703</a> (maximum speed)
0x00B80023	Int. overflow <a href="#">C02705</a> (maximum acceleration)
0x00B80024	Int. overflow <a href="#">C02708/1</a> (limited speed 1)
0x00B80025	Int. overflow <a href="#">C02708/2</a> (limited speed 2)
0x00B80026	Int. overflow <a href="#">C02708/3</a> (limited speed 3)
0x00B80027	Int. overflow <a href="#">C02708/4</a> (limited speed 4)
0x00B80028	Int. overflow <a href="#">C02710/1</a> (decel. limited speed 1)
0x00B80029	Int. overflow <a href="#">C02710/2</a> (decel. limited speed 2)
0x00B8002A	Int. overflow <a href="#">C02710/3</a> (decel. limited speed 3)
0x00B8002B	Int. overflow <a href="#">C02710/4</a> (decel. limited speed 4)
0x00B8002C	Int. overflow <a href="#">C02713</a> (maximum distance manual jog)
0x00B8002D	Int. overflow <a href="#">C02642</a> (home position)
0x00B8002E	Int. overflow <a href="#">C02643</a> (homing: target position)
0x00B8002F	Int. overflow <a href="#">C02644</a> (homing: speed 1)
0x00B80030	Int. overflow <a href="#">C02645</a> (homing: acceleration 1)
0x00B80031	Int. overflow <a href="#">C02646</a> (homing: speed 2)
0x00B80032	Int. overflow <a href="#">C02647</a> (homing: acceleration 2)
0x00B80033	Int. overflow <a href="#">C02670</a> (positioning: tolerance for target position)



#### Tip!

Possible measures for error correction:

- Plausibility check of the machine parameters set for gearbox ratio, feed constant, or resolution of an encoder revolution.
- Set parameters with a counter overflow to a value which can also be represented internally.

### 4.2 Device commands

In the following subchapters the device commands of the controller are described, which are provided in [C00002](#) and which can be executed by means of »Engineer« or alternatively with the keypad when an online connection has been established.



#### Note!

Before switching off the supply voltage after a device command has been executed, check the successful execution of the device command via the status display in [C00003](#)!

The meaning of the status display in [C00003](#) can be obtained from the subchapter for the corresponding device command.

#### Activating frequently required device commands via the toolbar

The simplest way to execute the frequently required device commands is directly via the *Toolbar* of »Engineer« when an online connection has been established.

Symbol	Job title
	<a href="#">Enable controller</a>
	<a href="#">Inhibit controller</a>
	<a href="#">Start application</a>
	<a href="#">Inhibit controller</a> and <a href="#">Stop application</a>



#### Note!

Device commands that can be executed via the *Toolbar* of the »Engineer« always affect the element currently selected in the *Project view* including all subelements!

- If no controller but a system module is selected in the *Project view*, the corresponding device command will be activated in all lower-level controllers having an online connection with the »Engineer«.

Before the desired action is carried out, a confirmation prompt appears first, asking whether the action is really to be carried out.

### Activating device commands via the "Device commands" dialog box

All device commands of the controller are available in »Engineer« in the *Device Commands* dialog box:

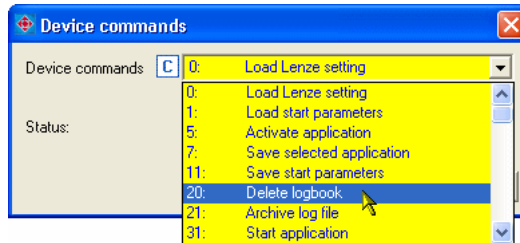

- The *Device commands* dialog box can be opened by clicking on the **Device commands** list field on the **Application parameters** tab in the dialog level *Overview* → *Drive interface*.
- The *Device commands* dialog box can also be opened by clicking the setting of [C00002](#) on the **All parameters** tab.



### Note!

If you click a device command in the list field of the *Device commands* dialog box, the corresponding device command is executed immediately!

- During and after the execution of the device command, the processing status is displayed in the *Device Commands* dialog box:

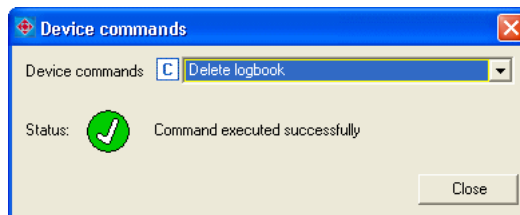

### 4.2.1 Load Lenze setting

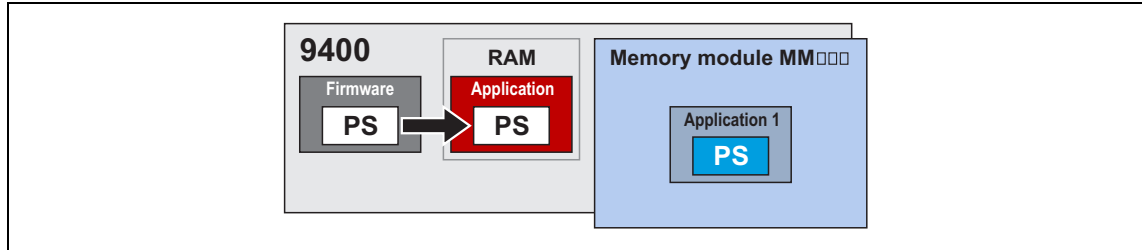

The [C00002](#) = "0: Load Lenze setting" device command is used to reset the parameters of the active application to the Lenze setting, which is stored in the controller firmware:



[4-12] "Load Lenze setting" function

- Only possible when the application has stopped and the controller is inhibited.
- All parameter changes made since the last saving of the parameter set will get lost!
- This device command only affects the settings of the operating system, application and module parameters, the active application or the configuration selected with the function block editor remains unchanged.

#### Possible status displays for this device command

Status ( <a href="#">C00003</a> )	Meaning
	34050 Device command in process
	0 Device command executed successfully
	1 General error
	39424 CAN fault
	... ...
	39679 CAN fault

#### Related device commands

- ▶ [Load start parameters](#) ([📖 48](#))
- ▶ [Save start parameters](#) ([📖 52](#))

# 4 Drive interface

## 4.2 Device commands

### 4.2.2 Load start parameters

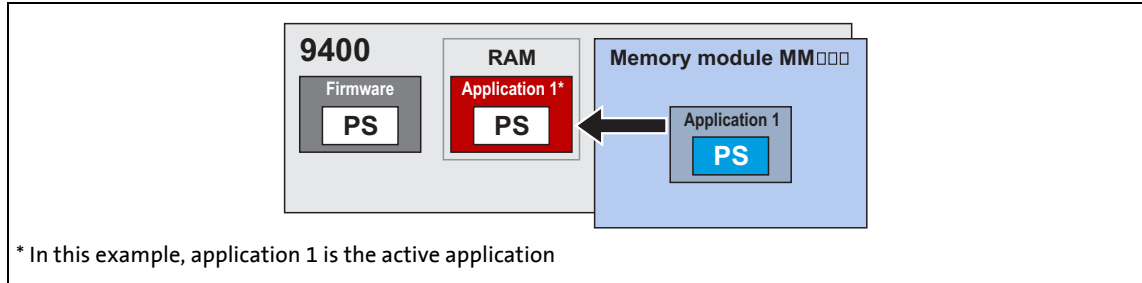

Via [C00002](#) = "1: Load start parameters" the start parameters of the active application can be reloaded from the memory module to the controller:



[4-13] "Load start parameters" function

- Only possible when the application has stopped and the controller is inhibited.
- All parameter changes made since the last saving of the parameter set will get lost!
- This device command only affects the settings of the operating system, application and module parameters, the active application or the configuration selected with the function block editor remains unchanged.

#### Possible status displays for this device command

Status ( <a href="#">C00003</a> )	Meaning
	99586 Device command in process
	65536 Device command executed successfully
	65537 General error
	99371 Fault while reading the parameter set partition
	99374 No memory module available
	104960 CAN fault
	... ..
105215 CAN fault	

#### Related device commands

- ▶ [Save start parameters](#) ([📖 52](#))
- ▶ [Load Lenze setting](#) ([📖 47](#))



### 4.2.3 ENP:Load plant data

If the Lenze motor connected to the controller is provided with an electronic nameplate (ENP), all motor data are automatically read out from the electronic nameplate of the motor when the controller is switched on for the first time and are temporarily stored in the controller at first.

With the device command [C00002](#) = "2: ENP: Load plant data" the motor data can be reread from the electronic nameplate (ENP) of the motor.

- Only possible when the application has stopped and the controller is inhibited.
- For a permanent acceptance of the motor data, the parameter set must be saved. ▶ [Save start parameters](#) (□ 52)
- The following plant data are read out from the ENP:

Parameters	Info
<a href="#">C00022</a>	Maximum current
<a href="#">C00070</a>	Speed controller gain
<a href="#">C00071</a>	Speed controller reset time
<a href="#">C00596</a>	Threshold max. speed reached





#### Note!

The two pieces of plant data [C00011](#) and [C00497](#) listed in the following table are not read out from the ENP and thus have to be checked and, if required, set manually after this device command has been executed!

Parameters	Info
<a href="#">C00011</a>	Reference speed motor
<a href="#">C00497</a>	Speed act. val. time const.

#### Possible status displays for this device command

Status ( <a href="#">C00003</a> )	Meaning
 165122	Device command in process
 131072	Device command executed successfully
 131073	General error

### 4.2.4 Activate application

Use the device command [C00002](#) = "5: Activate application" to activate the application archived on the memory module.

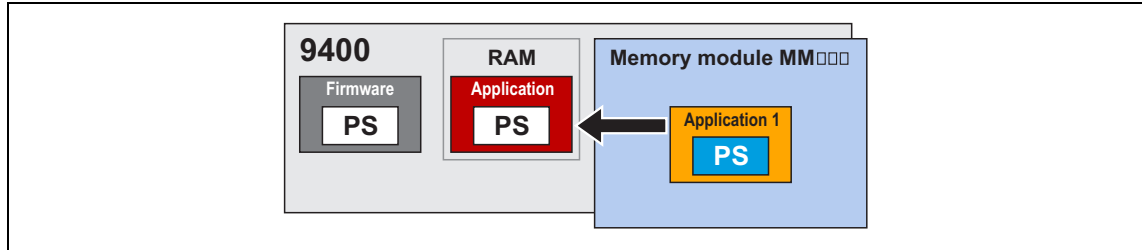

[4-14] "Activate application" function



- Only possible when the application has stopped and the controller is inhibited.
- Whether the application is started at the same time, depends on the auto-start setting selected in [C02104](#).
- After mains switching, the preset application will be loaded into the controller.
- The number of the currently active application is displayed with "1" in [C00007](#) after the download via the »Engineer«.



#### Note!

When the application is activated, the corresponding start parameter set is loaded automatically and parameter settings executed before will get lost unless the parameter set was saved before!

#### Possible status displays for this device command

Status ( <a href="#">C00003</a> )	Meaning
 361730	Device command in process
 327680	Device command executed successfully
 327681	General error

#### Related device commands

- ▶ [Save selected application](#) ([51](#))
- ▶ [Start application](#) ([56](#)) / ▶ [Stop application](#) ([57](#))

# 4 Drive interface

## 4.2 Device commands

### 4.2.5 Save selected application

With the device command [C00002](#) = "7: Save selected application" the active application can be defined as start application.

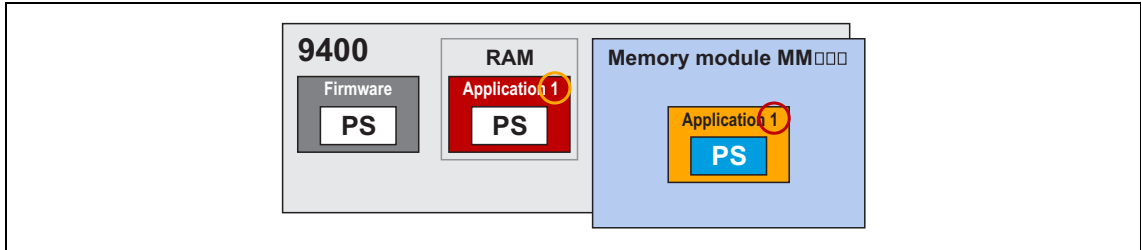

[4-15] "Save selected application" function

- When this device command is executed, the parameter set is also saved automatically.
- The number of the currently active application is displayed in [C00007](#).





#### Note!

The application "0" (Lenze setting) is intended for the Lenze service.

During initial commissioning, the download with the Engineer causes the application "1" archived on the memory module to be defined as start application.

#### Possible status displays for this device command

Status ( <a href="#">C00003</a> )	Meaning
 492802	Device command in process
 458752	Device command executed successfully
 458753	General error

#### Related device commands

- ▶ [Activate application](#) (📖 50)
- ▶ [Start application](#) (📖 56)
- ▶ [Stop application](#) (📖 57)

### 4.2.6 Save start parameters

Controller parameter changes made via »Engineer« or keypad will get lost after mains switching of the controller or loading of another application unless the settings have been explicitly saved.

With the device command [C00002](#) = "11: Save start parameters" the current parameter settings of the active application can be saved with mains failure protection in the memory module of the controller:

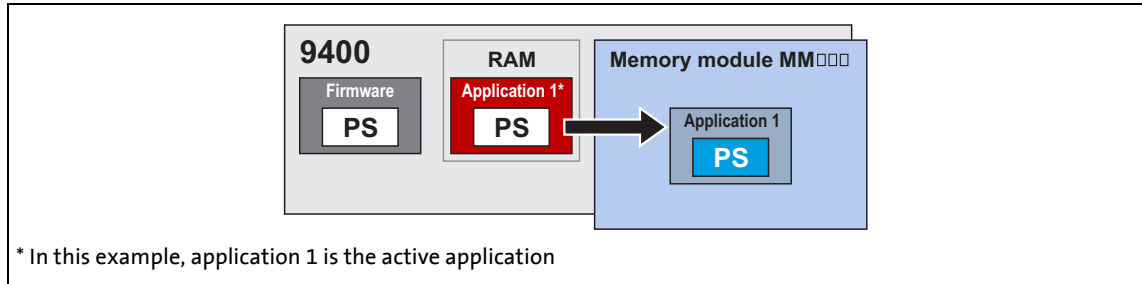

[4-16] "Save start parameters" function



#### Tip!

With the keypad this device command can be executed via the left function key if it is currently assigned with the **SAVE** function.



#### Note!



The saving process can take several seconds. Before you switch off the supply voltage after having executed this device command, therefore be absolutely sure to check via the status display in [C00003](#) whether the device command has been executed successfully!

#### Saving of the cam data

From software version V4.0, this device command also includes the powerfail-proof saving of the cam data on the memory module.

- The saving process is only carried out if the cam data in the controller and the memory module differ from each other (based on the time stamp/GUID of the cam data).
- For saving the cam data, you do not need to enter a possibly existing user password ([C02900](#)).
- The [C00002](#) = "502: Save Cam Data" device command remains available. ▶ [Save cam data](#) (□ 92)

## Possible status displays for this device command

Status (C00003)	Meaning
	754946 Device command in process
	720896 Device command executed successfully
	720897 General error
	754718 Fault while writing into a file
	754734 No memory module available
	761857 Access to file has been denied since the file is already accessed from another position
	761861 I/O fault when accessing the file system
	761868 RAM is full
	761869 Access authorisation denied
761884 No free memory on the memory module	

## Related device commands

▶ [Load start parameters](#) (📖 48)

### 4.2.7 Delete logbook

The [C00002](#) = "20: Delete logbook" device command is used to delete all entries in the logbook.





#### Tip!

To display the logbook in the »Engineer«, click the **Logbook** button on the **Diagnostics** tab. In the *Logbook* dialog box, it is also possible to delete all logbook entries by clicking the **Delete** button.

Further information on the logbook can be found in the chapter "[Diagnostics & fault analysis](#)". ([📖 608](#))

#### Possible status displays for this device command

Status ( <a href="#">C00003</a> )	Meaning
 1344770	Device command in process
 1310720	Device command executed successfully
 1310721	General error

#### Related device commands

▶ [Archive logbook](#) ([📖 55](#))

### 4.2.8 Archive logbook

The [C00002](#) = "21: Archive logbook" device command is used to archive the entries in the logbook.





#### Tip!

To display the logbook in the »Engineer«, click the **Logbook** button on the **Diagnostics** tab. You can also export all entries available in the logbook into a file (\*.log) by clicking the **Export** button in the *Logbook* dialog box.

Further information on the logbook can be found in the chapter "[Diagnostics & fault analysis](#)". ([📖 608](#))

#### Possible status displays for this device command

Status ( <a href="#">C00003</a> )	Meaning
 1410306	Device command in process
 1376256	Device command executed successfully
 1376257	General error

#### Related device commands

▶ [Delete logbook](#) ([📖 54](#))

### 4.2.9 Start application

The [C00002](#) = "31: Start application" device command is used to start the active application in the controller.

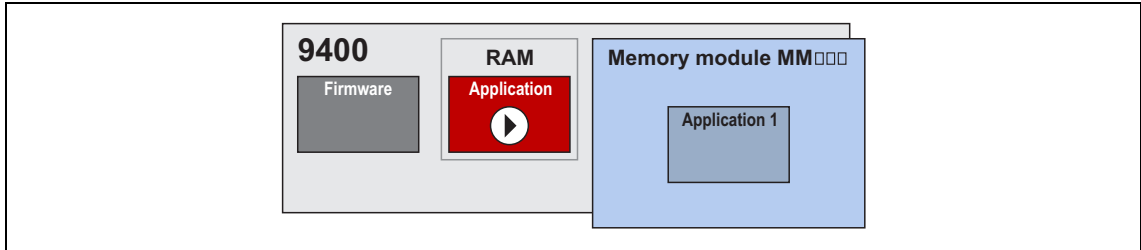

[4-17] "Start application" function



- The number of the currently active application is displayed with "1" in [C00007](#).
- The current program status is displayed in [C02108](#).
- The active function state of the application is displayed in [C02530](#).



**Tip!**

This device command can also be activated via the  icon in the *Toolbar*.

#### Possible status displays for this device command

Status ( <a href="#">C00003</a> )	Meaning
 2065666	Device command in process
 2031616	Device command executed successfully
 2031617	General error

#### Related device commands

- ▶ [Stop application](#) ([📖 57](#))
- ▶ [Activate application](#) ([📖 50](#))
- ▶ [Save selected application](#) ([📖 51](#))



### 4.2.10 Stop application

The [C00002](#) = "32: Stop application" device command can be used to stop the application started in the controller again.

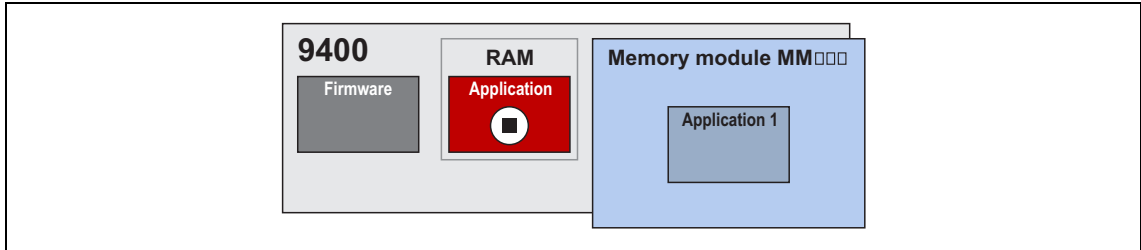

[4-18] "Stop application" function



- Only possible when the controller is inhibited.



**Tip!**

Via the  icon in the *Toolbar* the controller can be inhibited, and at the same time the application in the controller can be stopped.

#### Possible status displays for this device command

Status ( <a href="#">C00003</a> )	Meaning
 2131202	Device command in process
 2097152	Device command executed successfully
 2097153	General error

#### Related device commands



- ▶ [Start application](#) (📖 56)
- ▶ [Inhibit controller](#) (📖 63)
- ▶ [Activate application](#) (📖 50)
- ▶ [Save selected application](#) (📖 51)

### 4.2.11 Reset program

The [C00002](#) = "33: Reset program" device command is used to reset the application program in the controller.

- All variables are reset to their initialisation value.
- The situation corresponds to the start of a new program loaded into the control (cold start).

#### Possible status displays for this device command

Status ( <a href="#">C00003</a> )	Meaning
 2196738	Device command in process
 2162688	Device command executed successfully
 2162689	General error

#### Related device commands



- ▶ [Delete program](#) ([📖 59](#))
- ▶ [Restart program](#) ([📖 60](#))

### 4.2.12 Delete program

The [C00002](#) = "34: Delete program" device command is used to delete the application program in the controller and reset the controller to its original state.

- All variables are reset to their initialisation value.

#### Possible status displays for this device command

Status ( <a href="#">C00003</a> )	Meaning
 2262274	Device command in process
 2228224	Device command executed successfully
 2228225	General error

#### Related device commands



- ▶ [Reset program](#) ([📖 58](#))
- ▶ [Restart program](#) ([📖 60](#))

### 4.2.13 Restart program

The [C00002](#) = "35: Restart program" device command is used to restart the application program in the controller.

- All variables except the RETAIN variables are reset to their initialisation value.
- The situation corresponds to a power failure or switching the controller off/on (warm start) while the program is running.

#### Possible status displays for this device command

Status ( <a href="#">C00003</a> )	Meaning
 2327810	Device command in process
 2293760	Device command executed successfully
 2293761	General error

#### Related device commands

- ▶ [Reset program](#) ([📖 58](#))
- ▶ [Delete program](#) ([📖 59](#))

# 4 Drive interface



## 4.2 Device commands

### 4.2.14 Reset runtime measurement

When the application is started, the controller continuously carries out a runtime measurement for the interval-controlled application task, the interval-controlled user task, and the free-running idle task and displays the current and maximum task runtimes via parameters.

The [C00002](#) = "36: Reset runtime measurement" device command is used to reset the runtime measurement, i.e. the memory for the maximum values is reset to "0".

#### Possible status displays for this device command

Status ( <a href="#">C00003</a> )	Meaning
 2393346	Device command in process
 2359296	Device command executed successfully
 2359297	General error



#### Note!

The runtime measurement is also reset by the following actions:

- Start application
- Reset/delete/restart program

#### Example for runtime measurement

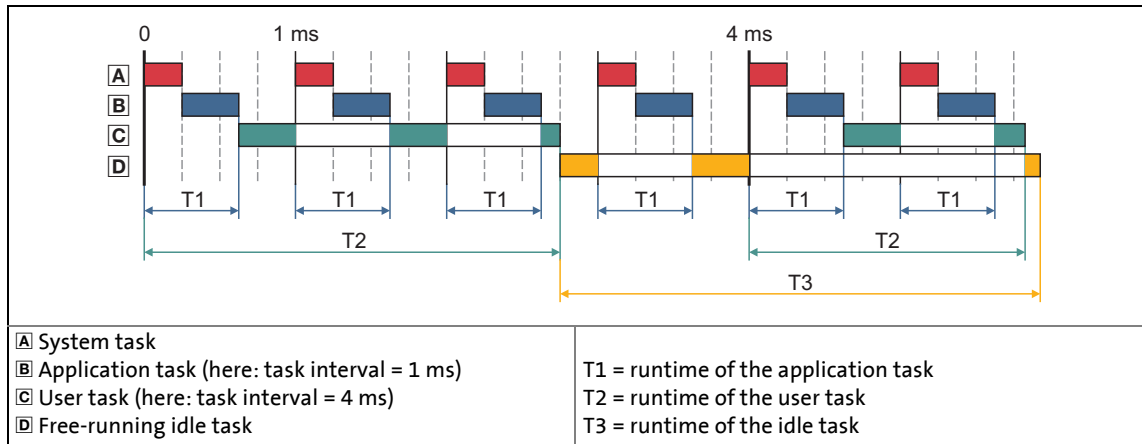

[4-19] Example: Runtimes of the different tasks

# 4 Drive interface

## 4.2 Device commands

---

### Display parameter

Parameters	Info	Lenze setting	
		Value	Unit
<a href="#">C02121/1</a>	Current runtime - application task	-	µs
<a href="#">C02121/2</a>	Maximum runtime - application task	-	µs
<a href="#">C02122/1</a>	Current runtime - user task	-	µs
<a href="#">C02122/2</a>	Maximum runtime - user task	-	µs
<a href="#">C02123/1</a>	Current runtime - idle task	-	µs
<a href="#">C02123/2</a>	Maximum runtime - idle task	-	µs

Greyed out = display parameter

### 4.2.15 Inhibit controller

The [C00002](#) = "41: Inhibit controller" device command is used to inhibit the controller ("controller inhibit"), i.e. the power output stages in the controller are inhibited and the speed/current and position controllers of the motor control are reset. The motor becomes torqueless and coasts unless it is already at standstill.

- The controller can also be inhibited by other sources, e.g. via the digital input RFR or through the application.
- [C00158](#) provides a bit coded representation of all active sources/triggers of a controller inhibit.



#### Note!

This device command has no status display in [C00003](#), i.e. the display remains unchanged showing the previous device command status.



#### Tip!

This device command can also be activated via the  icon in the *Toolbar*.

#### Related device commands

- ▶ [Enable controller](#) (📖 64)

### 4.2.16 Enable controller

The [C00002](#) = "42: Enable controller" device command is used to re-enable an inhibited controller.



#### Note!

Please note that the controller will only be enabled if all sources for controller inhibit are reset!

- [C00158](#) provides a bit coded representation of all active sources/triggers of a controller inhibit.

This device command has no status display in [C00003](#), i.e. the display remains unchanged showing the previous device command status.



#### Tip!

This device command can also be activated via the  icon in the *Toolbar*.

#### Related device commands

- ▶ [Inhibit controller](#) (📖 63)



### 4.2.17 Reset error

The [C00002](#) = "43: Reset error" device command is used to acknowledge an error message if the error cause has been eliminated and the error is thus no longer pending.



#### Tip!

An error message can also be acknowledged by activating the **Reset error** button in the **Diagnostics** tab.

Further information on error messages can be found in the chapter "[Diagnostics & fault analysis](#)". (📖 608)



#### Note!

This device command has no status display in [C00003](#), i.e. the display remains unchanged showing the previous device command status.

### 4.2.18 Activate quick stop

The [C00002](#) = "45: Activate quick stop" device command is used to activate the basic function "Quick stop", i. e. the drive is brought to standstill within the deceleration time set, irrespective of the setpoint defined.

- Quick stop can also be activated by other sources, e.g. by the application.
- [C00159](#) displays a bit code of active sources/causes for the quick stop.



#### Note!

The activation of quick stop may cause following errors in superimposed controls (e.g. synchronous or position control). If several drives execute a coordinated movement, the quick stop function should therefore only be used for the motion master (master drive) in order to maintain the coordination.

This device command has no status display in [C00003](#), i.e. the display remains unchanged showing the previous device command status.



#### Tip!

In contrast to the "stop" function, quick stop is required for a stop in the event of an error. Thus, quick stop can also be set as an error response ("quick stop by trouble) for many monitoring functions. Detailed information on this can be found in the chapter "[Diagnostics & fault analysis](#)". ([📖 608](#))

#### Related device commands

- ▶ [Reset quick stop](#) ([📖 67](#))

### 4.2.19 Reset quick stop

The [C00002](#) = "46: Reset quick stop" device command is used to exit an active quick stop again.



#### Note!

Please note that the quick stop is only exited if all sources for quick stop are reset!

- [C00159](#) displays a bit code of active sources/causes for the quick stop.

This device command has no status display in [C00003](#), i.e. the display remains unchanged showing the previous device command status.

#### Related device commands

- ▶ [Activate quick stop](#) (📖 66)

### 4.2.20 Identify pole position (360°)

If no absolute value encoder is connected, or a synchronous motor of a third-party manufacturer is driven by the controller, the [C00002](#) = "51: Identify pole position (360°)" device command is used to determine the pole position with regard to the motor encoder currently activated in [C00495](#).

- The function can only be activated if the controller is inhibited. Then the execution of the function starts automatically as soon as the controller inhibit is deactivated again.
- During the pole position identification, the motor carries out one electrical revolution. This leads to a mechanical rotation of the motor shaft.
- The determined pole position is indicated under code [C00058](#).



#### Note!



From software version V4.0 the response parameterised in [C00640](#) (Lenze setting: "Fault") is triggered and the error message "Pole position identification cancelled" is entered in the logbook of the controller if the pole position identification process is aborted.



#### Tip!

Detailed information on the pole position identification can be found in the chapter "Motor interface", subchapter "[Pole position identification](#)". ([📖 131](#))

#### Possible status displays for this device command

Status ( <a href="#">C00003</a> )	Meaning
	3376386 Device command in process
	3342336 Device command executed successfully
	3342337 General error
	3382023 Pole position identification cannot be executed because of wrong motor type (asynchronous motor).
	3382024 Pole position identification has been aborted
	3382025 Pole position identification cannot be executed because another identification is already active.
	3382026 Identification of pole position cannot be executed because U-rotation or I-rotation test mode is active.
	3382027 Identification of pole position cannot be executed because current controller optimisation mode is active.
	3382033 Pole position identification cannot be executed because the motor is blocked (e.g. by a mechanical brake), a motor phase is not connected, or a phase shifter is in the motor cable.
	3382047 Pole position identification cannot be executed because an error or trouble is active.
3382065 Pole position identification cannot be executed because either the entire motor or a motor phase is not connected. • This error message is only available from software version V3.0 onwards.	

#### Related device commands

- ▶ [Identify pole position \(min. motion\)](#) ([📖 69](#))

### 4.2.21 Identify pole position (min. motion)

If no absolute value encoder is connected, or a synchronous motor of a third-party manufacturer is driven by the controller, the [C00002](#) = "52: Identify pole position (min. motion)" device command is used to determine the pole position with respect to the motor encoder currently activated in [C00495](#).

- The function can only be activated if the controller is inhibited. Then the execution of the function starts automatically as soon as the controller inhibit is deactivated again.
- During the pole position identification, the rotor aligns itself. This is compensated by a position control.
- The determined pole position is indicated under code [C00058](#).



#### Note!



From software version V4.0 the response parameterised in [C00640](#) (Lenze setting: "Fault") is triggered and the error message "Pole position identification cancelled" is entered in the logbook of the controller if the pole position identification process is aborted.



#### Tip!

Detailed information on the pole position identification can be found in the chapter "Motor interface", subchapter "[Pole position identification](#)". ([131](#))

#### Possible status displays for this device command

Status ( <a href="#">C00003</a> )	Meaning
	3441922 Device command in process
	3407872 Device command executed successfully
	3407873 General error
	3447559 Pole position identification cannot be executed because of wrong motor type (asynchronous motor).
	3447560 Pole position identification has been aborted
	3447561 Pole position identification cannot be executed because another identification is already active.
	3447562 Identification of pole position cannot be executed because U-rotation or I-rotation test mode is active.
	3447563 Identification of pole position cannot be executed because current controller optimisation mode is active.
	3447569 Pole position identification cannot be executed because the motor is blocked (e.g. by a mechanical brake), a motor phase is not connected, or a phase shifter is in the motor cable. • This error message is only available from software version V4.0 onwards.
	3447583 Pole position identification cannot be executed because an error or trouble is active.
	3447597 Identification of pole position cannot be executed because the rotor has moved too strongly.
3447601 Pole position identification cannot be executed because either the entire motor or a motor phase is not connected. • This error message is only available from software version V3.0 onwards.	

# 4 Drive interface

## 4.2 Device commands

---

### Related device commands

- ▶ [Identify pole position \(360°\)](#) (📖 68)

### 4.2.22 Resolver error identification

This function extension is available from software version V7.0!

The [C00002](#) = "59: Resolver error identification" device command serves to detect resolver errors which are caused when sine and cosine tracks do not magnetise orthogonally. The identified resolver errors serve to compensate the resolver errors.



- Only possible with servo control.



**Tip!**

Detailed information on the resolver error compensation can be found in the chapter "Encoder evaluation" in the subchapter "[Resolver error compensation](#)". (□ 266)

#### Possible status displays for this device command

Status ( <a href="#">C00003</a> )	Meaning
 3900674	Device command in process
 3866624	Device command executed successfully
	3866625 General error
	3906358 Resolver error identification cannot be executed since the wrong control type is active (no servo control).
	3906359 Resolver error identification cannot be executed since an error or trouble is active.
	3906360 Resolver error identification cannot be executed because another identification is already active.
3906361	Resolver error identification cannot be executed because of too small speed (< 500 rpm).

### 4.2.23 Load Lenze INV characteristic

This function extension is available from software version V4.0!

If determination of the so-called "inverter error characteristic" is not possible with the device command "[Calculate inv. characteristic](#)" or leads to incorrect results, the device command [C00002](#) = "70: Load Lenze INV characteristic" can be used to load a characteristic which is typical of the device in question.



- Only possible when the controller is inhibited.



#### Tip!

Detailed information about the determination of the inverter error characteristic can be found in the chapter "Motor interface" in the subchapter "[Optimising the switching performance of the inverter](#)". (📖 138)

#### Possible status displays for this device command

Status ( <a href="#">C00003</a> )	Meaning
 4621570	Device command in process
 4587520	Device command executed successfully
 4587521	General error

#### Related device commands

- ▶ [Calculate inv. characteristic](#) (📖 73)



### 4.2.24 Calculate inv. characteristic

If a motor of a third-party manufacturer with unknown motor parameters is driven by the controller, the [C00002](#) = "71: Determine inverter characteristic" device command can be used to determine the so-called "Inverter error characteristic" for optimising the inverter switching performance.





#### Tip!

Detailed information about the determination of the inverter error characteristic can be found in the chapter "Motor interface" in the subchapter "[Optimising the switching performance of the inverter](#)". (📖 138)

**From software version V4.0:** If the inverter error characteristic cannot be determined by means of this device command, or if the results of the determination are incorrect, the device command "[Load Lenze INV characteristic](#)" can be used to load a characteristic typical of the device. (📖 72)

#### Possible status displays for this device command

Status ( <a href="#">C00003</a> )	Meaning
	4687106 Device command in process
	4653056 Device command executed successfully
	4653057 General error
	4692754 The calculation of the inverter characteristic cannot be started since the current controller test mode is active.
	4692755 The calculation of the inverter characteristic cannot be started since the V/f test mode is active.
	4692756 The calculation of the inverter characteristic cannot be started since the pole position identification is active.
	4692757 Calculation of the inverter characteristic has been aborted.
	4692758 Calculation of the inverter characteristic has been interrupted by error.
	4692789 Determined inverter error characteristic exceeds internal limits. <ul style="list-style-type: none"> <li>• This situation can for instance occur if the motor power is very much lower than the device power.</li> <li>• <a href="#">This error message is only available from software version V5.0 onwards.</a></li> </ul>

#### Related device commands

- ▶ [Load Lenze INV characteristic](#) (📖 72)

# 4 Drive interface

## 4.2 Device commands

### 4.2.25 Determine motor parameters

The [C00002](#) = "72: Determine motor parameters" device command is used to automatically determine the motor parameters for a third-party motor that are listed in the following table – if they are not known:



Parameters	Info	ASM	SM
<a href="#">C00079</a>	Motor magnetising inductance	<input checked="" type="checkbox"/>	
<a href="#">C00082</a>	Motor rotor resistance	<input checked="" type="checkbox"/>	
<a href="#">C00084</a>	Motor stator resistance	<input checked="" type="checkbox"/>	<input checked="" type="checkbox"/>
<a href="#">C00085</a>	Motor stator leakage inductance	<input checked="" type="checkbox"/>	<input checked="" type="checkbox"/>
<a href="#">C00091</a>	Motor cosine phi	<input checked="" type="checkbox"/>	
<a href="#">C00092</a>	Motor magnetising current	<input checked="" type="checkbox"/>	



#### Tip!

Detailed information about the automatic determination of the motor parameters can be found in the chapter "Motor interface" in the subchapter "[Determining the motor parameters](#)". (📖 141)

#### Possible status displays for this device command

Status ( <a href="#">C00003</a> )	Meaning
 4752642	Device command in process
 4718592	Device command executed successfully
	4718593 General error
	4758290 Motor identification cannot be started since the current controller test mode is active.
	4758291 Motor identification cannot be started since the V/f test mode is active.
	4758292 Motor identification cannot be started because pole position identification is active.
	4758293 Motor identification has been aborted.
	4758294 Motor identification has been aborted by fault.
4758332	Motor identification aborted due to inconsistent motor parameters. • <a href="#">This error message is only available from software version V7.0 onwards.</a>

### 4.2.26 Calculate current controller parameters

This function extension is available from software version V5.0 onwards!

The device command [C00002](#) = "77: Calculate current controller parameters" is used to calculate the gain and the reset time of the current controller for a third-party motor.

**Precondition:** The two motor parameters "stator resistance" ([C00084](#)) and "stator leakage inductance" ([C00085](#)) either have been parameterised manually on the basis of the manufacturer information before, or have been determined automatically via the device command "[Determine motor parameters](#)".



#### Note!

For a Lenze motor the calculation and the subsequent optimisation of the current controller parameters is not required, as the correct current controller parameters are accepted from »Engineer« motor catalogue.

The device command is no identification procedure for determining the current controller parameters!

- The calculation is carried out according to the following formulas:

$$\text{Gain} = \frac{\text{Stator leakage inductance}}{340 \mu\text{s}}$$
$$\text{Reset time} = \frac{\text{Stator leakage inductance}}{\text{Stator resistance}}$$

- After the device command has been executed successfully (see status in [C00003](#)), the two calculated values are set in [C00075](#) and [C00076](#). They serve as starting values for a subsequent optimisation of the current controller in the test mode.
- In the event of an error, codes [C00075](#) and [C00076](#) are not altered.





#### Tip!

Detailed information on the optimisation of the current controller in the test mode can be found in the chapter "Motor interface" in the subchapter for the respective motor control:

- Servo control (SC) ▶ [Optimise current controller](#) (147)
- Sensorless vector control (SLVC) ▶ [Optimise current controller](#) (181)
- V/f control (VFCplus) ▶ [Optimise current controller](#) (196)

### Possible status displays for this device command

Status (C00003)	Meaning
	5080322 Device command in process
	5046272 Device command executed successfully
	5046273 General error
	5086002 At least one calculated value is outside the valid setting range.
	5086003 Stator resistance ( <a href="#">C00084</a> ) too small (zero).

### Related device commands

- ▶ [Determine motor parameters](#) (📖 74)
- ▶ [Calculate speed controller parameters](#) (📖 77)

### 4.2.27 Calculate speed controller parameters

This function extension is available from software version V5.0 onwards!

The device command [C00002](#) = "78: Calculate speed controller parameters" is used to calculate the gain, reset time, and rate time of the speed controller.

**Precondition:** The moments of inertia for the motor ([C00273/1](#)) and load ([C00273/2](#)) have been parameterised correctly before.



#### Note!

The device command is no identification procedure for determining the speed controller parameters!

- The calculation is carried out according to the following formulas, taking the actual speed value filter time constant into consideration ([C00497](#)):

$$\text{Gain} = \frac{\text{Moment of inertia of motor+load}}{4 \cdot (\text{Actual speed value filter time constant} + 500 \mu\text{s})} \cdot \frac{2\pi}{60}$$

$$\text{Reset time} = 4^2 \cdot (\text{Actual speed value filter time constant} + 500 \mu\text{s})$$

$$\text{Rate time} = 0 \text{ ms}$$

- After the device command has been executed successfully (see status in [C00003](#)), the calculated values are set in the corresponding codes:
  - [C00070](#): Speed controller gain
  - [C00071](#): Speed controller reset time
  - [C00072](#): Speed controller rate time
- In the event of an error, these codes are not altered.

#### Possible status displays for this device command

Status ( <a href="#">C00003</a> )	Meaning
5145858	Device command in process
5111808	Device command executed successfully
5111809	General error
	5151540

#### Related device commands

- ▶ [Calculate current controller parameters](#) (□ 75)

### 4.2.28 CAN on board: Reset Node



The [C00002](#) = "91: CAN on board: reset node" device command is used to reinitialise the CANopen system bus interface of the controller ("CAN on board"), which is required, for instance, after the data transfer rate, node address, or identifiers have been changed.



#### Tip!

For detailed information about the "CAN on board" CANopen system bus interface, please see the "CAN" Communication Manual.

#### Possible status displays for this device command

Status ( <a href="#">C00003</a> )	Meaning
	5997826 Device command in process
	5963776 Device command executed successfully
	5963777 General error
	6003200 CAN fault
	... ..
	6003455 CAN fault

#### Related device commands

- ▶ [CAN on board: Pred.Connect.Set](#) ([📖 80](#))
- ▶ [CAN on board: Identify node](#) ([📖 82](#))

### 4.2.29 CAN module: Reset node



The [C00002](#) = "92: CAN module: reset node" device command is used to reinitialise the CANopen interface of a CANopen communication module in module slot MXI1 or MXI2, which is required, for instance, after the data transfer rate, node address, or identifiers have been changed.



#### Tip!

Detailed information on the CANopen communication module (E94AYCCA) can be found in the "CAN" Communication Manual.

#### Possible status displays for this device command

Status ( <a href="#">C00003</a> )	Meaning
	6063362 Device command in process
	6029312 Device command executed successfully
	6029313 General error
	6068736 CAN fault
	...
	6068991 CAN fault

#### Related device commands

- ▶ [CAN module: Pred.Connect.Set](#) (📖 81)
- ▶ [CAN module: Identify node](#) (📖 83)

# 4 Drive interface

## 4.2 Device commands

### 4.2.30 CAN on board: Pred.Connect.Set



The [C00002](#) = "93: CAN on board: Pred.Connect.Set" device command is used to set the basic identifiers for the CANopen system bus interface of the controller ("CAN on board") according to the "Predefined Connection Set" (DS301V402).



**Tip!**

For detailed information about the "CAN on board" CANopen system bus interface, please see the "CAN" Communication Manual.

#### Possible status displays for this device command

Status ( <a href="#">C00003</a> )	Meaning
 6128898	Device command in process
 6094848	Device command executed successfully
 6094849	General error

#### Related device commands

- ▶ [CAN on board: Reset Node](#) ([📖 78](#))
- ▶ [CAN on board: Identify node](#) ([📖 82](#))



### 4.2.31 CAN module: Pred.Connect.Set



The [C00002](#) = "94: CAN module: pred.connect.set" device command is used to set the basic identifiers for the CANopen system bus interface of a CANopen communication module in module slot MXI1 or MXI2 according to the "Predefined Connection Set" (DS301V402).



#### Tip!

Detailed information on the CANopen communication module (E94AYCCA) can be found in the "CAN" Communication Manual.

#### Possible status displays for this device command

Status ( <a href="#">C00003</a> )	Meaning
 6194434	Device command in process
 6160384	Device command executed successfully
 6160385	General error

#### Related device commands

- ▶ [CAN module: Reset node](#) ([📖 79](#))
- ▶ [CAN module: Identify node](#) ([📖 83](#))

### 4.2.32 CAN on board: Identify node

The [C00002](#) = "95: CAN on board: identify node" device command is used to determine the nodes connected to the CANopen system bus interface of the controller ("CAN on board").



- The result of the CAN bus scan is displayed in [C00393](#).



#### Tip!

For detailed information about the "CAN on board" CANopen system bus interface, please see the "CAN" Communication Manual.

#### Possible status displays for this device command

Status ( <a href="#">C00003</a> )	Meaning
 6259970	Device command in process
 6225920	Device command executed successfully
 6225921	General error

#### Related device commands

- ▶ [CAN on board: Reset Node](#) (📖 78)
- ▶ [CAN on board: Pred.Connect.Set](#) (📖 80)

### 4.2.33 CAN module: Identify node

The [C00002](#) = "96: CAN module: identify node" device command is used to determine the nodes connected to the CANopen system bus interface of a CANopen communication module in module slot MXI1 or MXI2.



- The result of the CAN bus scan is displayed in C13393 (for MXI1) or in C14393 (for MXI2).



#### Tip!

Detailed information on the CANopen communication module (E94AYCCA) can be found in the "CAN" Communication Manual.

#### Possible status displays for this device command

Status ( <a href="#">C00003</a> )	Meaning
 6325506	Device command in process
 6291456	Device command executed successfully
 6291457	General error

#### Related device commands

- ▶ [CAN module: Reset node](#) ( 79)
- ▶ [CAN module: Pred.Connect.Set](#) ( 81)

### 4.2.34 Unbind/bind Ethernet module MXI1



The [C00002](#) = "101: Unbind/bind Ethernet module: MXI1" device command is used to reinitialise the Ethernet interface of an Ethernet communication module in module slot MXI1, e. g. to accept a newly set IP or gateway address without mains switching.



#### Tip!

Detailed information on the Ethernet communication module (E94AYCEN) can be found in the "Ethernet" Communication Manual.

#### Possible status displays for this device command

Status ( <a href="#">C00003</a> )	Meaning
 6653186	Device command in process
 6619136	Device command executed successfully
 6619137	General error

#### Related device commands

- ▶ [Unbind/bind Ethernet module MXI2](#) ( 85)

# 4 Drive interface

## 4.2 Device commands

---

### 4.2.35 Unbind/bind Ethernet module MXI2



The [C00002](#) = "102: Unbind/bind Ethernet module: MXI2" device command is used to reinitialise the Ethernet interface of an Ethernet communication module in module slot MXI2, e. g. to accept a newly set IP or gateway address without mains switching.



#### Tip!

Detailed information on the Ethernet communication module (E94AYCEN) can be found in the "Ethernet" Communication Manual.

#### Possible status displays for this device command

Status ( <a href="#">C00003</a> )	Meaning
 6718722	Device command in process
 6684672	Device command executed successfully
 6684673	General error

#### Related device commands

- ▶ [Unbind/bind Ethernet module MXI1](#) ( 84)

### 4.2.36 Activate parameter set 1 ... 4

In addition to the start parameters, up to four further parameter sets can be stored in the memory module for each application. Like this you can for instance define different controller settings for an application, which are then simply activated via device command, if required.

The following device commands can be used to activate the parameter set 1 ... 4 for the active application (if available on the memory module):

[C00002](#) = "201: Activate parameter set 1"

[C00002](#) = "202: Activate parameter set 2"

[C00002](#) = "203: Activate parameter set 3"

[C00002](#) = "204: Activate parameter set 4"

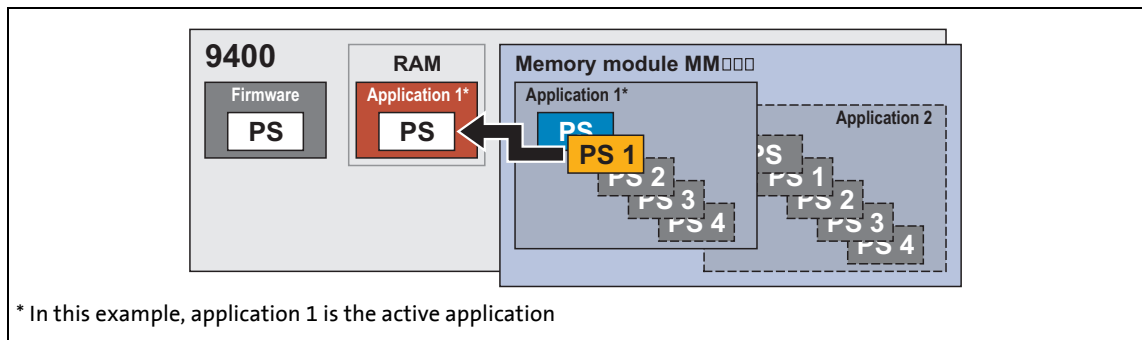



[4-20] Example: "Activate parameter set 1" function

- Only possible when the application has stopped and the controller is inhibited.
- All parameter changes of the previously active parameter set carried out since the last saving will get lost!
- These device commands only affect the settings of the operating system, application, and module parameters; the active application, or a configuration selected with the function block editor remain unchanged.

# 4 Drive interface

## 4.2 Device commands

### Possible status displays for these device commands

Status (C00003)	for command				Meaning
	201	202	203	204	
	13206786	13272322	13337858	13403394	Device command in process
	13172736	13238272	13303808	13369344	Device command executed successfully
	13172731	13238273	13303809	13369345	General error
	13206532	13272068	13337604	13403140	File could not be opened.
	13206557	13272093	13337629	13403165	Fault while reading out of a file.
	13206558	13272094	13337630	13403166	Fault while writing into a file.
	13206559	13272095	13337631	13403167	Invalid file type.
	13206560	13272096	13337632	13403168	Unexpected end of file.
	13206562	13272098	13337634	13403170	Checksum error
	13212160	13277696	13343232	13408768	CAN fault
	...	...	...	...	...
	13212415	13277951	13343487	13409023	CAN fault
	13213697	13279233	13344769	13410305	Access to file has been denied since the file is already accessed from another position
	13213701	13279237	13344773	13410309	I/O fault when accessing the file system
	13213708	13279244	13344780	13410316	RAM is full
13213709	13279245	13344781	13410317	Access authorisation denied	
13213724	13279260	13344796	13410332	No free memory on the memory module	

### Related device commands

▶ [Activate parameter set 1 ... 4](#) (📄 88)

# 4 Drive interface

## 4.2 Device commands

### 4.2.37 Activate parameter set 1 ... 4

In addition to the start parameters, up to four further parameter sets can be stored in the memory module for each application. Like this you can for instance define different controller settings for an application, which are then simply activated via device command, if required.

The following device commands are used to archive the current parameter settings of the controller for the active application in the memory module as parameter set 1 ... 4:

C00002 = "301: Archive parameter set 1"

C00002 = "302: Archive parameter set 2"

C00002 = "303: Archive parameter set 3"

C00002 = "304: Archive parameter set 4"

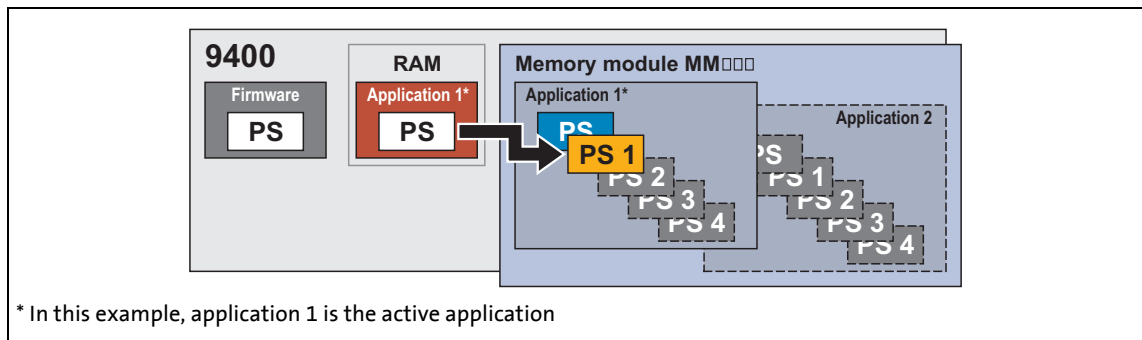

[4-21] Example: "Archive parameter set 1" function



- Previously archived parameter settings will be overwritten with the current parameter settings!



# 4 Drive interface

## 4.2 Device commands

### Possible status displays for these device commands

Status (C00003)	for command				Meaning
	301	302	303	304	
	19760386	19825922	19891458	19956994	Device command in process
	19726336	19791872	19857408	19922944	Device command executed successfully
	19726337	19791873	19857409	19922945	General error
	19760132	19825668	19891204	19956740	File could not be opened.
	19760157	19825693	19891229	19956765	Fault while reading out of a file.
	19760158	19825694	19891230	19956766	Fault while writing into a file.
	19760160	19825696	19891232	19956768	Unexpected end of file.
	19767297	19832833	19898369	19963905	Access to file has been denied since the file is already accessed from another position
	19767301	19832837	19898373	19963909	I/O fault when accessing the file system
	19767308	19832844	19898380	19963916	RAM is full
	19767309	19832845	19898381	19963917	Access authorisation denied
19767324	19832860	19898396	19963932	No free memory on the memory module	

### Related device commands

▶ [Activate parameter set 1 ... 4](#) (86)

### 4.2.38 Load cam data

This function extension is available from software version V3.0!

The [C00002](#) = "501: Load cam data" device command serves to reload cam data from the memory module into the controller.



#### Note!

If you transfer the parameter set or the application from »Engineer« to the controller, the cam data are also transferred automatically to the controller.

- The new/altered cam data are accepted in the controller according to the online change mode set.
- Thus, normally this device command does not need to be executed manually.

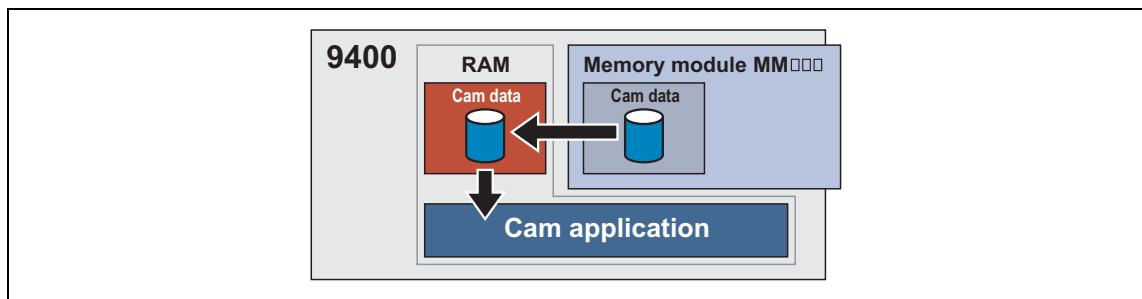

[4-22] "Load cam data" function

- Only possible when the application has stopped and the controller is inhibited.
- If the cam data are provided with an access protection, the user password has to be entered in [C02900](#) first.





#### Tip!

Detailed information on the online change mode and the access protection can be found in the chapter "Basic drive functions", subchapter "[Cam data management](#)". ([📖 557](#))

#### Procedure

1. The cam data are completely loaded from the memory module into the main memory of the controller.
2. The present cam data in the application unit are converted to the internal unit [increments] and are reorganised.
3. The processed cam data are stored in a separate main memory that can be accessed by the cam application.

### Possible status displays for this device command

Status (C00003)	Meaning
	32867586 Device command in process
	32833536 Device command executed successfully
	32833537 General error
	32875521 No cam data available on the memory module
	32875523 Loading of the cam data failed
	32875525 Checksum error
	32875542 Wrong password entered
	32875545 The cam functionality is deactivated

### Related device commands

- ▶ [Save cam data](#) (📖 92)
- ▶ [Calculate cam data](#) (📖 94)
- ▶ [Calculate cam data checksum](#) (📖 95)

### 4.2.39 Save cam data

This function extension is available from software version V3.0!

The [C00002](#) = "502: Save cam data" device command serves to save the cam data available in the main memory of the controller with mains failure protection in the memory module.

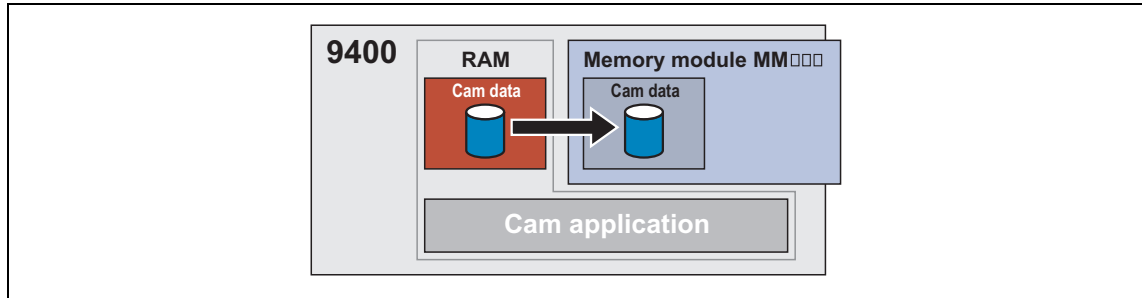

[4-23] "Save cam data" function

- This function is executed in the background and is also possible when the controller is enabled and the application is running.
  - However, this function is only executed if valid cam data are available.
  - The cam data can also be saved if previously no cam data have been available on the memory module.
- While the function is executed, no online change and no change of the cam data via parameters can be carried out.

For software versions lower than V4.0 the following applies:

- If the cam data are provided with an access protection, the user password has to be entered in [C02900](#) first.

The following applies from software version V4.0:



- For saving the cam data, you do not need to enter a possibly existing user password ([C02900](#)).



#### Tip!

Detailed information on the access protection can be found in the chapter "Basic drive functions", subchapter "[Cam data management](#)". ([557](#))

### Possible status displays for this device command

Status (C00003)	Meaning
	32933122 Device command in process
	32899072 Device command executed successfully
	32899073 General error
	32941057 No cam data to be saved are available in the RAM of the controller
	32941060 Saving of the cam data failed
	32941078 Wrong password entered
	32941081 The cam functionality is deactivated

### Related device commands

- ▶ [Load cam data](#) (📖 90)
- ▶ [Calculate cam data](#) (📖 94)
- ▶ [Calculate cam data checksum](#) (📖 95)

### 4.2.40 Calculate cam data

This function extension is available from software version V3.0!

The [C00002](#) = "503: Calculate cam data" device command converts the cam data stored in the main memory of the controller to the internal format and makes them available to the application. This, for instance, is necessary if one or more machine parameters affecting the internal scaling of cam data have been changed.



- The status signal *bNewDataAvailable* of the basic drive function "[Cam data management](#)" ([LS\\_CamInterface](#) system block) is set to TRUE and the cam data are accepted automatically or manually depending on the online change mode set. After successful data acceptance, the status signal *bNewDataAvailable* is automatically reset to FALSE.
- The user password does not have to be entered in [C02900](#).
- While the function is executed, no online change and no change of the cam data via parameters can be carried out.
- This function is executed in the background and can also be activated when the controller is enabled and the application is running.



#### Tip!

Detailed information on the cam functionality can be found in the chapter "Basic drive functions", subchapter "[Cam data management](#)". ([📖 557](#))

#### Possible status displays for this device command

Status ( <a href="#">C00003</a> )	Meaning
 32998658	Device command in process
 32964608	Device command executed successfully
	32964609 General error
	33006617 The cam functionality is deactivated

#### Related device commands

- ▶ [Load cam data](#) ([📖 90](#))
- ▶ [Save cam data](#) ([📖 92](#))
- ▶ [Calculate cam data checksum](#) ([📖 95](#))

### 4.2.41 Calculate cam data checksum

This function extension is available from software version V3.0!

The [C00002](#) = "504: Calculate cam data checksum" device command is used to recalculate the checksum of the cam data available in the main memory of the controller. This is required if the cam data in the main memory of the controller have been changed via parameters. Afterwards the cam data can be converted to the internal format using the "503: Calculate cam data" device command, or they can be saved with mains failure protection in the memory module using the "502: Save cam data" device command.



- The user password does not have to be entered in [C02900](#).
- This function is executed in the background and can also be activated when the controller is enabled and the application is running.



#### Tip!

Detailed information on the cam functionality can be found in the chapter "Basic drive functions", subchapter "[Cam data management](#)". ([📖 557](#))

#### Possible status displays for this device command

Status ( <a href="#">C00003</a> )	Meaning
 33064194	Device command in process
 33030144	Device command executed successfully
	33030145 General error
	33072153 The cam functionality is deactivated

#### Related device commands

- ▶ [Load cam data](#) ([📖 90](#))
- ▶ [Save cam data](#) ([📖 92](#))
- ▶ [Calculate cam data](#) ([📖 94](#))

### 4.2.42 Format file system

The [C00002](#) = "1030: Format file system" device command is used to format the file system in the memory module.



#### Note!

By means of this device command all folders and files in the file system of the memory module are irrevocably deleted!

The application has to be downloaded again with »Engineer«.

#### Possible status displays for this device command

Status ( <a href="#">C00003</a> )	Meaning
67536130	Device command in process
67502080	Device command executed successfully
67502081	General error

#### Related device commands

- ▶ [Restore file system](#) ([📖 97](#))



### 4.2.43 Restore file system

The [C00002](#) = "1040: Restore file system" device command is used to execute a low level formatting of the file system in the memory module.



#### Note!

By means of this device command all folders and files in the file system of the memory module and all pieces of internal information for the management of the file system are irrevocably deleted!

This device command has no status display in [C00003](#), i.e. the display remains unchanged showing the previous device command status.



#### Stop!

The low level formatting of the file system by the user is only intended for the exceptional case when the standard formatting of the file system via the [C00002](#) = "1030: Format file system" device command is no longer possible, e.g. due to damaged internal management information.

#### Related device commands

▶ [Format file system](#) (📖 96)

### 4.2.44 Prepare firmware update





#### Note!

For Lenze service only!

The [C00002](#) = "10000: Prepare firmware update" device command is used to set the controller to the firmware update mode to update the firmware, if required, using the corresponding software.

- Only possible when the application has stopped and the controller is inhibited.

#### Possible status displays for this device command

Status ( <a href="#">C00003</a> )	Meaning
 655394050	Device command in process
 655360000	Device command executed successfully
 655360001	General error

# 4 Drive interface

## 4.2 Device commands



---

### 4.2.45 Restart controller

The [C00002](#) = "11000: Restart controller" device command is used to restart the controller via parameter setting.

- Only possible when the application has stopped and the controller is inhibited.

#### Possible status displays for this device command

Status ( <a href="#">C00003</a> )	Meaning
 720930050	Device command in process
 720896001	General error



#### Note!

Due to the restart at the successful execution of the device command, this status is no longer displayed in [C00003](#).

If this device command is used, the message "Undervoltage in the DC bus (0x007b000f)" may appear in the logbook.

# 4 Drive interface

## 4.3 Device states

### 4.3 Device states

The state control of the drive is controlled internally via a state machine which can adopt the following "device states":

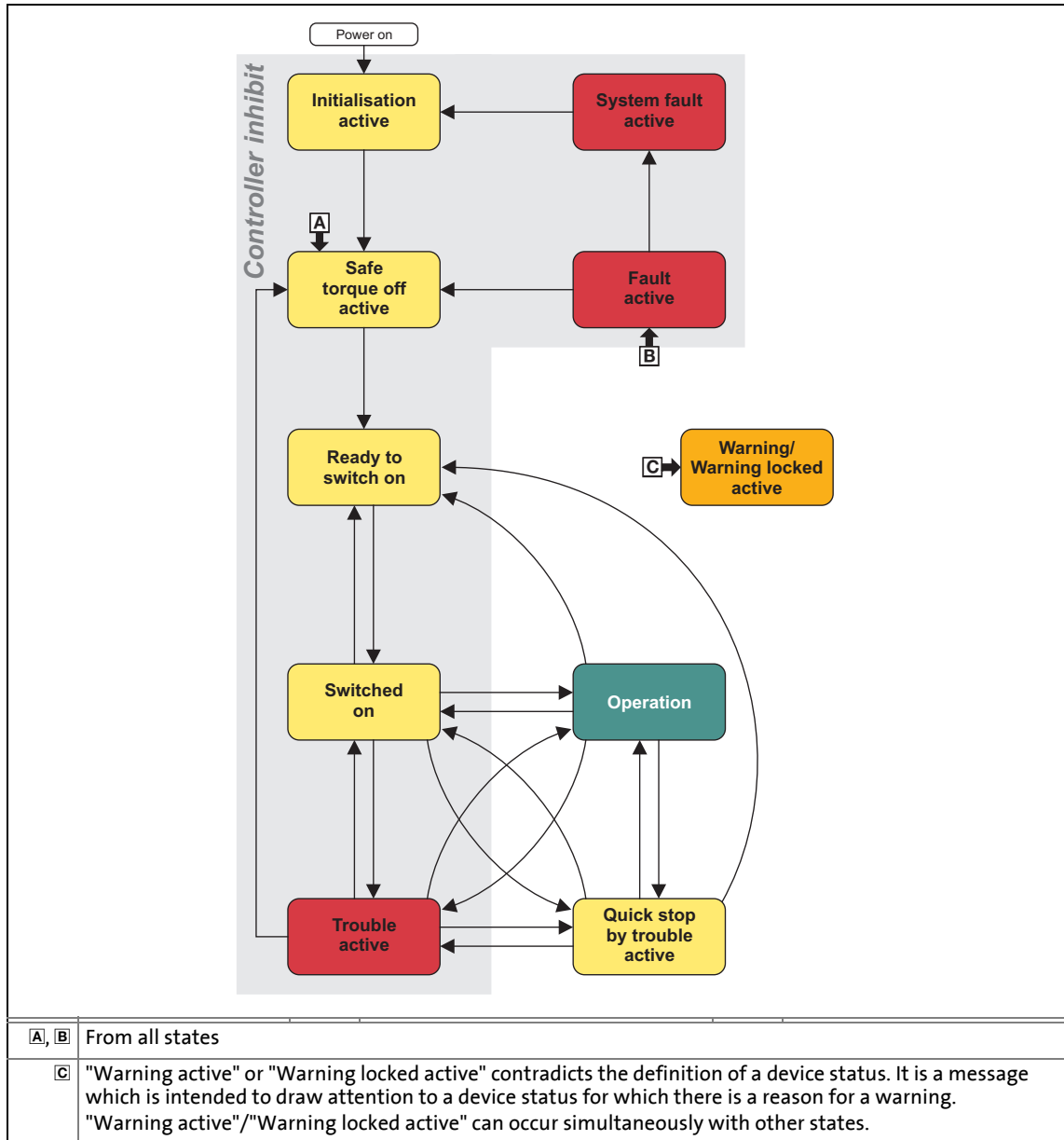

[4-24] Device state machine



### Note!

The device states of the controller must not be confused with the function states of the [Basic drive functions](#). (377)

- In the device state "Operation" the [Basic drive functions](#) define the motion control of the drive.

### Display parameters for diagnostic purposes

- In [C00183](#) the current device state is shown.
- In [C00150](#) (status word 1) the current device state is shown in a bit coded manner via bits 8 ... 11:

Bit 11	Bit 10	Bit 9	Bit 8	Meaning
0	0	0	0	"Initialisation active" state
0	0	0	1	"Device is ready to switch on" state
0	0	1	0	-
0	0	1	1	"Device is switched on" state
0	1	0	0	-
0	1	0	1	-
0	1	1	0	"Operation" state
0	1	1	1	"Trouble active" state
1	0	0	0	-
1	0	0	1	-
1	0	1	0	"Quick stop by trouble active" state
1	0	1	1	"Safe torque off active" state Observe LED on the safety module!
1	1	0	0	"Fault active" state
1	1	0	1	-
1	1	1	0	-
1	1	1	1	-
x	x	x	x	Displayed message " <a href="#">Warning active</a> " or " <a href="#">Warning locked active</a> " The displayed message can occur at the same time as the device states "Device is ready to switch on", "Device is switched on" and "Operation", if a monitoring component responds for which the error response "Warning" has been parameterised.

- [C02530](#) displays the active function state.

### LED status display

The control of the two LEDs "DRIVE READY" and "DRIVE ERROR" in the middle of the controller's front panel depends on the device state. ▶ [LED status displays for the device state](#) (□ 609)

# 4 Drive interface

## 4.3 Device states

### Influence of the status signals of the SB LS\_DriveInterface by the device state

Device status	Status signals (Outputs of the SB LS_DriveInterface)						
	DI_bReady	DI_bFail Active	DI_bImp Active	DI_bCInh Active	DI_bWarning Active	DI_bReady ToSwitchOn	DI_bOperation Enabled
<a href="#">Initialisation active</a>	FALSE	FALSE	TRUE	TRUE	FALSE	FALSE	FALSE
<a href="#">Safe torque off active</a>	FALSE	FALSE	TRUE	TRUE	TRUE/FALSE	FALSE	FALSE
<a href="#">Device is ready to switch on</a>	FALSE	FALSE	TRUE	TRUE	TRUE/FALSE	TRUE	FALSE
<a href="#">Device is switched on</a>	TRUE	FALSE	TRUE	TRUE	TRUE/FALSE	FALSE	FALSE
<a href="#">Operation</a>	TRUE	FALSE	FALSE	FALSE	TRUE/FALSE	FALSE	TRUE
<a href="#">Warning active</a>	TRUE/FALSE	TRUE/FALSE	TRUE/FALSE	TRUE/FALSE	TRUE	TRUE/FALSE	TRUE/FALSE
<a href="#">Warning locked active</a>	TRUE/FALSE	TRUE/FALSE	TRUE/FALSE	TRUE/FALSE	TRUE	TRUE/FALSE	TRUE/FALSE
<a href="#">Quick stop by trouble active</a>	FALSE	TRUE	FALSE	FALSE	TRUE/FALSE	FALSE	FALSE
<a href="#">Trouble active</a>	FALSE	FALSE	TRUE	TRUE	TRUE/FALSE	FALSE	FALSE
<a href="#">Fault active</a>	FALSE	TRUE	TRUE	TRUE	TRUE/FALSE	FALSE	FALSE
<a href="#">System fault active</a>	FALSE	TRUE	TRUE	TRUE	TRUE/FALSE	FALSE	FALSE

▶ [Internal interfaces | "LS\\_DriveInterface" system block \(113\)](#)

### 4.3.1 "Initialisation active" state

LED DRIVE READY	LED DRIVE ERROR	Display in <a href="#">C00183</a>
OFF	OFF	10: Initialisation active

This is the status of the controller directly after switching on the supply voltage.

- In this device state the operating system is initialised.
- The monitoring functions are not active yet.
- Communication is not possible yet.
- The controller cannot be parameterised yet and no device commands can be carried out yet.
- When the device initialisation is completed, the device state is automatically changed to "Safe torque off active".

### 4.3.2 "Safe torque off active" state

LED DRIVE READY	LED DRIVE ERROR	Display in <a href="#">C00183</a>
	OFF	101: Safe torque off active

This device state becomes active if the controller receives the "Safe torque off" request by the safety module.

- "Drive is torqueless" (0x00750003) is entered in the logbook.
- If no corresponding request by the safety module is available, a change to the subsequent state "Device is ready to switch on" is effected.



#### Note!

The "Safe torque off active" status is also passed through after an error has been acknowledged (see illustration [\[4-24\]](#)).

### 4.3.3 "Device is ready to switch on" state

LED DRIVE READY	LED DRIVE ERROR	Display in <a href="#">C00183</a>
	OFF	"Device is ready to switch on"

This is the device state of the controller directly after the initialisation has been completed and where no DC-bus voltage is applied yet.

- The bus systems are running and the terminals and encoders are evaluated.
- The monitoring functions are active.
- The controller can be parameterised and device commands can be executed to a limited extent.
- The functions of the user task can be used.
  - Precondition: The application has started (status display in [C02108](#)).
- The basic drive functions cannot be used yet.



#### Note!

The "Device is ready to switch on" status is not only activated after mains connection but also after reset of "Trouble", "Fault", or "Safe torque off active".

- In order to change from the "Device is ready to switch on" to the "Device is switched on" status when [C00142](#) = "0: inhibited", at least one of the controller inhibit sources must be active.
- When [C00142](#) = "1: Enabled", the "Device is ready to switch on" status directly changes to the "Device is switched on" status.



### Danger!

If automatic restart is enabled ([C00142](#) = "1: Enabled"), the drive can restart automatically from the "Trouble" and "Safe torque off" device states when the trouble or request for "Safe torque off active" has been eliminated!

▶ [Automatic restart after mains connection/trouble...](#) (📖 107)

### 4.3.4 "Device is switched on" state

LED DRIVE READY	LED DRIVE ERROR	Display in <a href="#">C00183</a>
	OFF	90: Drive is switched on

The drive is in this device status if the DC bus voltage is applied and the controller is still inhibited by the user (controller inhibit).

- The bus systems are running and the terminals and encoders are evaluated.
- The monitoring functions are active.
- The controller can be parameterised and device commands can be executed to a limited extent.
- The functions of the user task can be used.
  - Precondition: The application has started (status display in [C02108](#)).
- The basic drive functions cannot be used yet.
- If the controller is enabled, the motor builds up a torque.

### 4.3.5 "Operation" state

LED DRIVE READY	LED DRIVE ERROR	Display in <a href="#">C00183</a>
	OFF	0: Operation



In this device state the motor follows its setpoint according to the basic drive function selected.



## 4 Drive interface

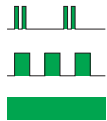

### 4.3 Device states

#### 4.3.6 "Warning active"

LED DRIVE READY	LED DRIVE ERROR	Display in <a href="#">C00183</a>
		1: Operation/warning active

This displayed message can occur at the same time as the device states "Device is ready to switch on", "Device is switched on" and "Operation", if a monitoring component responds for which the error response "Warning" has been parameterised.

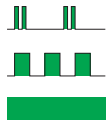
#### 4.3.7 "Warning locked active"

LED DRIVE READY	LED DRIVE ERROR	Display in <a href="#">C00183</a>
		2: Operation/warning locked active



This displayed message can occur at the same time as the device states "Device is ready to switch on", "Device is switched on" and "Operation", if a monitoring element responds for which the error response "Warning locked" has been parameterised.



#### Note!

Do not use this error response if a higher-level control unit with the CANopen device profile CiA402 (e.g. 9400 ServoPLC) is used.

#### 4.3.8 "Quick stop by trouble active" state

LED DRIVE READY	LED DRIVE ERROR	Display in <a href="#">C00183</a>
		151: Quick stop by trouble active

This device state becomes active as soon as a monitoring function responds for which the "Quick stop by trouble" error response has been parameterised.

- The drive is decelerated to standstill with torque within the deceleration time parameterised for quick stop independently of the defined setpoint and can be kept there.
- The device status can only be abandoned by acknowledging the error if the error cause is removed.
- It is also possible to skip to the "Device is switched on" state during the error status by setting controller inhibit, as controller inhibit has a higher priority. As long as the error is still available and has not been acknowledged, a change back to the "Quick stop by trouble active" state is effected when the controller is enabled afterwards.

## 4 Drive interface

### 4.3 Device states

---

#### 4.3.9 "Trouble active" state

LED DRIVE READY	LED DRIVE ERROR	Display in <a href="#">C00183</a>
OFF		104: Trouble active

This device state becomes active as soon as a monitoring function responds for which the "Trouble" error response has been parameterised.

- The motor has no torque (is coasting).
- The device state is automatically exited if the error cause is eliminated:
  - "Trouble active" state < 500 ms: Return to the original device state.
  - "Trouble active" state > 500 ms: Return via the device state "Safe torque off active".

#### 4.3.10 "Fault active" state

LED DRIVE READY	LED DRIVE ERROR	Display in <a href="#">C00183</a>
OFF		102: Fault active

This device state becomes active as soon as a monitoring function responds for which the "Fault" error response has been parameterised.

#### 4.3.11 "System fault active" state

LED DRIVE READY	LED DRIVE ERROR	Display in <a href="#">C00183</a>
OFF		20: System fault active

This device status becomes active if a system fault occurs.

- The device state can only be exited by mains switching.

## 4.4

## Automatic restart after mains connection/trouble...

## .../Fault/"Safe torque off active"

In [C00142](#), the starting performance of the controller after mains connection and reset of "Trouble", "Fault", or "Safe torque off active" can be parameterised.

**Danger!**

If automatic restart is enabled ([C00142](#) = "1: Enabled"), the drive can restart automatically from the "Trouble" and "Safe torque off" device states when the trouble or request for "Safe torque off active" has been eliminated!

**Note!**

From software version V4.0 the automatic restart is inhibited in the Lenze setting! Set the selection "1: Enabled" in [C00142](#) to obtain the former behaviour.

**Auto-start option 0: Auto restart inhibited after mains connection**

Controller inhibit always has to be set if the controller is to change from the "Ready to switch on" state to the "Switched on" state after mains connection or reset of "Trouble", "Fault", or "Safe torque off active". The following change to the "Operation" state is performed when the controller is enabled:

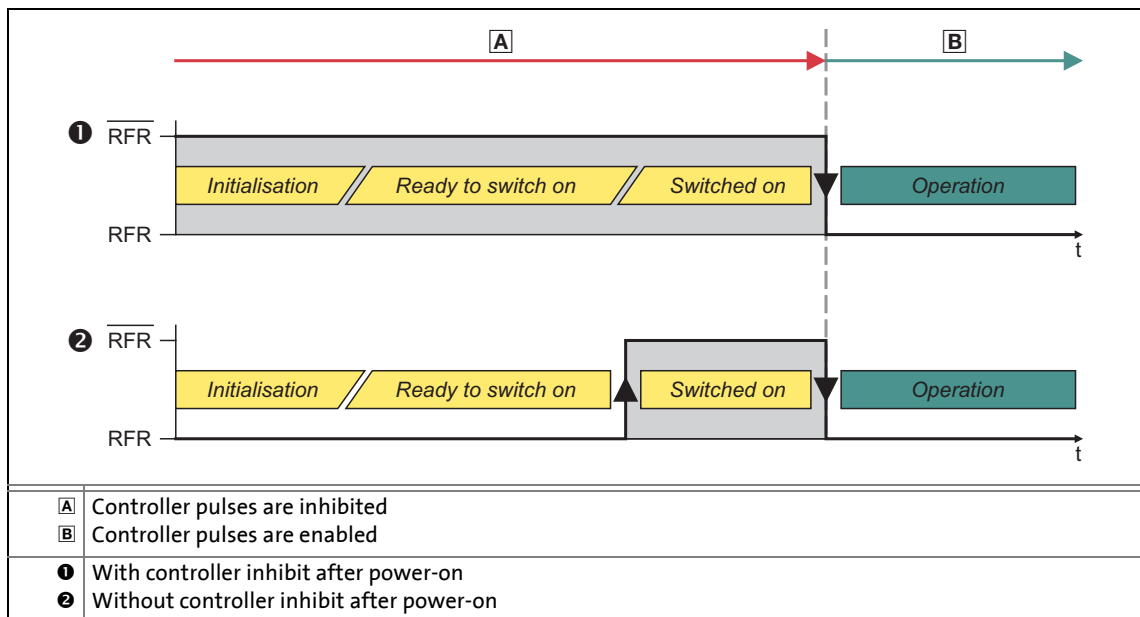

[4-25] State change when auto-restart is inhibited (C00142 = "0: Inhibited")

**Auto-start option 1: Auto restart enabled after mains connection**

The following illustration shows the state changes for the auto-start option 1 and their relationship to controller inhibit:

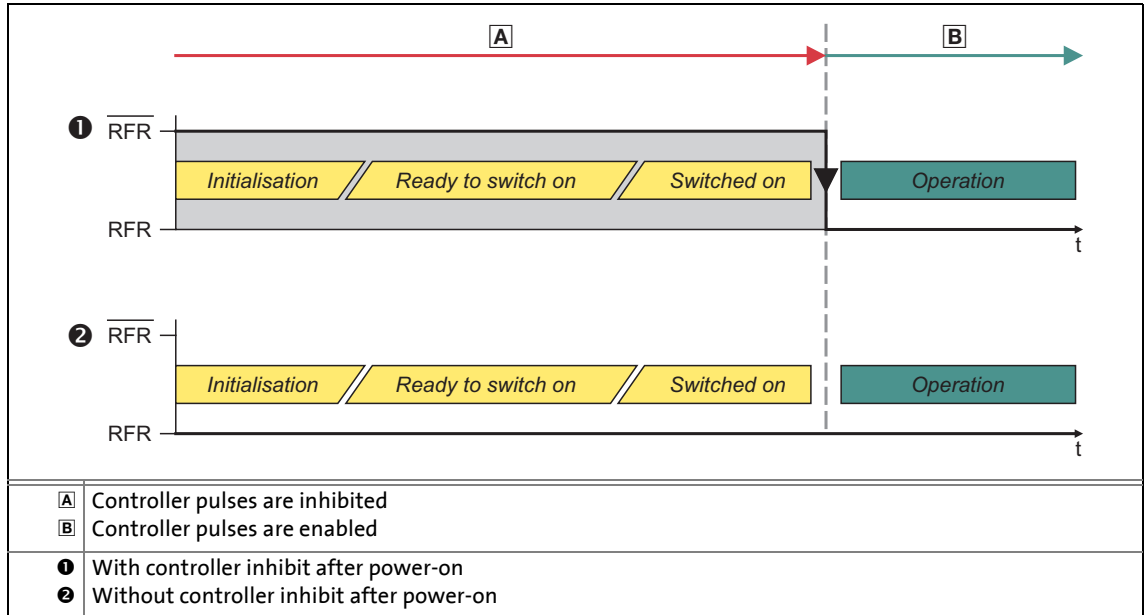

[4-26] State change when auto-restart is enabled (C00142 = "1: Enabled")

## 4 Drive interface

### 4.5 Behaviour after task overflow

---

#### 4.5 Behaviour after task overflow

Up to software version V5.0 the following applies:

- After a task overflow in the application or user task the "Error" response is effected.

The following applies from software version V5.0:

- In [C02111](#) the error response after a task overflow in the application or user task can be parameterised. The Lenze setting "Error" corresponds to the previous behaviour of the controller with software versions lower than V5.0.



#### Tip!

For a hoist for instance the "Quick stop by trouble" error response with engagement of the brake can be set, so that the drive is brought to standstill within the shortest time possible.

From »Engineer« version 2.10 onwards, the function block editor can also be used to configure the behaviour of the analog and digital outputs and that of the brake control and the output ports after a task overflow in order to adapt it to the respective application.

▶ [Configure exception handling of the outputs](#) (□ 293)

# 4 Drive interface

## 4.6 Device output power

### 4.6 Device output power

The parameters described in the following subchapters influence the output power of the controller.

#### 4.6.1 Switching frequency

The controller uses a pulse-width modulation to generate its output voltage. The switching frequency is used to change the control factor of the pulse-width modulation.

##### Automatic switching frequency reduction

In the Lenze setting, the "variable" switching frequency "8 kHz" has been selected in [C00018](#), which means that the controller automatically reduces the switching frequency depending on the setpoint current.

- Depending on the current amount, it is changed down to an assigned switching frequency.
- The switching thresholds are device-dependent (see 9400 hardware manual, chapter "Rated data").
- If a fixed switching frequency is selected in [C00018](#) instead of a variable one, there is no switching frequency changeover, however, (due to the field frequency range 0...5 Hz) it can only be traversed at a low continuous current and low maximum currents (see 9400 hardware manual, chapter "Rated data").



#### Note!

If parameterisation is carried out offline or if the memory module is exchanged between different 9400 HighLine device types, always check the setting of the switching frequency in [C00018](#) and adapt it, if required, to prevent a parameter error after the parameter set download or module change!

The maximum output frequency of the controller is limited to 1/8 of the switching frequency selected in [C00018](#)! (See the following table.)

Switching frequency ( <a href="#">C00018</a> ):	1 kHz	2 kHz	4 kHz	8 kHz	16 kHz	
Maximum output frequency:	125 Hz	250 Hz	500 Hz	1000 Hz	1999 Hz	
Motor - number of pole pairs:	Maximum speed [rpm]					
	1	7500	15000	30000	60000	120000
	2	3750	7500	15000	30000	60000
	3	2500	5000	10000	20000	40000
	4	1875	3750	7500	15000	30000
	5	1500	3000	6000	12000	24000
	6	1250	2500	5000	10000	20000



#### Tip!

If a load profile and a fixed setting of the switching frequency (e. g. 8 kHz fixed) are given, an I x t disconnection due to a high device utilisation can be avoided by selecting the variable setting for the same switching frequency instead. ▶ [Monitoring of the device utilisation](#)

## 4 Drive interface

### 4.6 Device output power

---

#### Reduced switching losses through switching frequency reduction

The advantage of a switching frequency reduction are the reduced switching losses in the controller, which are monitored via an  $I \times t$  evaluation.

- A reduced switching frequency enables a greater current-time area at the output than it would be the case with a higher switching frequency. However, depending on the process, you always have to make a compromise between the torque ripple and the output power.

#### 4.6.2 Monitoring of the device utilisation

In [C00064](#) the device utilisation ( $I \times t$ ) is displayed over the last 180 seconds in [%].

- If the value displayed in [C00064](#) exceeds the warning threshold set in [C00123](#), the error message "device utilisation  $I \times t > C00123$ " is output and the fault response set in [C00604](#) occurs (default setting: "Warning").
- If the value displayed in [C00064](#) exceeds 100 %, the error message "device utilisation  $I \times t > 100 \%$ " is output and the "Fault" error response occurs.
  - The fault can only be reset if the value displayed in [C00064](#) is  $< 95 \%$  again.

#### 4.6.3 Operation with increased continuous power

This function extension is available from software version V3.0!

If required, operation with an increased continuous power for the switching frequencies 1 kHz and 2 kHz can be activated in [C01199](#) for controllers from the device size 8S, if the following requirements are met:

- Controller is of E94AxxE1454 ... E94AxxE6954 type (device size 8S ... 10).
- The maximum current ([C00022](#)) is < 150 % of the rated device current.



#### Stop!

During operation with increased continuous power, the max. permissible ambient temperature is reduced to 40 °C.

The overload current must be reduced. An overload current of 180 % for 10 s is no longer permissible during operation with increased continuous power.



#### Note!

To activate operation with increased continuous power, controller inhibit must be set in the controller.

The "activated" setting in [C01199](#) is automatically reset to "deactivated" (without error message) if the previously mentioned requirements are not (no longer) met.

- This is also the case if the memory module is plugged into a controller of the small design 8 (device exchange).



#### Tip!

The permissible output currents and overload factors for operation with increased continuous power for different device types can be found in the Hardware Manual in the "Rated data" chapter.



## 4.7

## Internal interfaces | "LS\_DriveInterface" system block

The **LS\_DriveInterface** system block provides the internal interfaces to the drive interface in the function block editor.

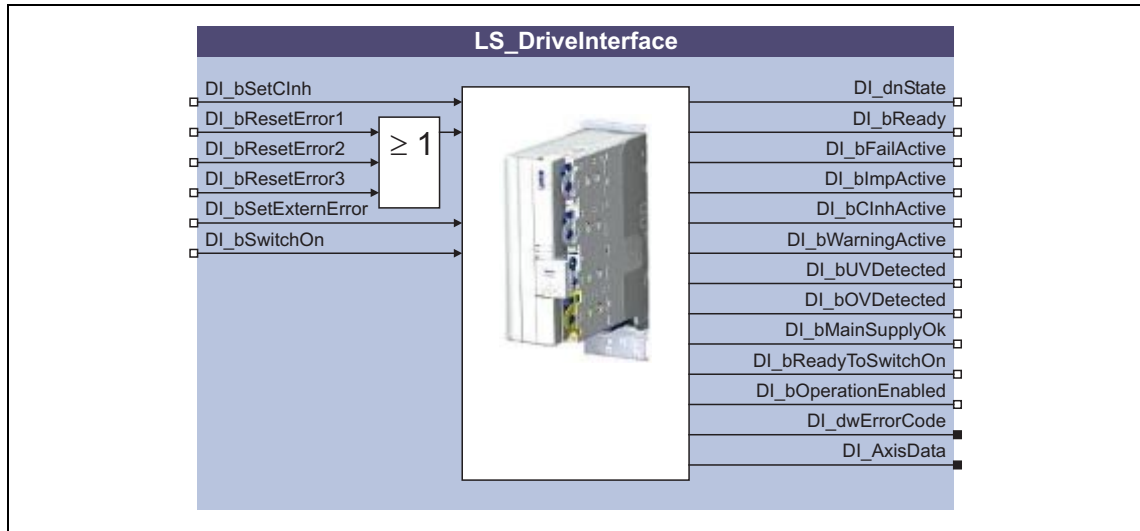

## Inputs

Identifier DIS code   data type	Information/possible settings				
DI_bSetClnh <a href="#">C02549/1</a>   BOOL	<p>Set/remove controller inhibit</p> <ul style="list-style-type: none"> <li>The controller can be inhibited by different sources, e.g. via the digital input RFR or using the device command "<a href="#">Inhibit controller</a>". (<a href="#">□ 63</a>)</li> <li>The bit code under <a href="#">C00158</a> shows the source that inhibited the controller.</li> </ul> <table border="1"> <tr> <td>TRUE</td> <td>Set controller inhibit. <ul style="list-style-type: none"> <li>The power output stages in the controller are inhibited and the speed, current, and position controller of the motor control are reset.</li> </ul> </td> </tr> <tr> <td>TRUE↔FALSE</td> <td>Remove controller inhibit. <ul style="list-style-type: none"> <li>Please note that the controller will only be enabled if <u>all</u> sources for controller inhibit are reset!</li> </ul> </td> </tr> </table>	TRUE	Set controller inhibit. <ul style="list-style-type: none"> <li>The power output stages in the controller are inhibited and the speed, current, and position controller of the motor control are reset.</li> </ul>	TRUE↔FALSE	Remove controller inhibit. <ul style="list-style-type: none"> <li>Please note that the controller will only be enabled if <u>all</u> sources for controller inhibit are reset!</li> </ul>
TRUE	Set controller inhibit. <ul style="list-style-type: none"> <li>The power output stages in the controller are inhibited and the speed, current, and position controller of the motor control are reset.</li> </ul>				
TRUE↔FALSE	Remove controller inhibit. <ul style="list-style-type: none"> <li>Please note that the controller will only be enabled if <u>all</u> sources for controller inhibit are reset!</li> </ul>				
DI_bResetError1 <a href="#">C02548/1</a>   BOOL	<p>Reset (acknowledge) error message</p> <ul style="list-style-type: none"> <li>This function resets an active error message if the cause of the error message has been eliminated.</li> <li>The three inputs are linked via a logic OR gate.</li> </ul>				
DI_bResetError2 <a href="#">C02548/2</a>   BOOL					
DI_bResetError3 <a href="#">C02548/3</a>   BOOL					
DI_bSetExternError <a href="#">C02548/4</a>   BOOL	<p>Activation of "External error" error message</p> <p>▶ <a href="#">Monitoring of external events</a> (<a href="#">□ 117</a>)</p> <table border="1"> <tr> <td>TRUE</td> <td>Activate error message with the response selected in <a href="#">C00581</a>.</td> </tr> </table>	TRUE	Activate error message with the response selected in <a href="#">C00581</a> .		
TRUE	Activate error message with the response selected in <a href="#">C00581</a> .				
DI_bSwitchOn <a href="#">C02549/4</a>   BOOL	<p>Deactivate switch-on inhibit</p> <ul style="list-style-type: none"> <li>If the automatic restart is inhibited (<a href="#">C00142</a> = "0"), the state machine remains in the "Device is ready to switch on" state after mains switching. <ul style="list-style-type: none"> <li>▶ "<a href="#">Device is ready to switch on</a>" state (<a href="#">□ 103</a>)</li> </ul> </li> </ul> <table border="1"> <tr> <td>FALSE↔TRUE</td> <td>The switch-on inhibit is deactivated and the controller changes to the device state "Device is switched on".</td> </tr> </table>	FALSE↔TRUE	The switch-on inhibit is deactivated and the controller changes to the device state "Device is switched on".		
FALSE↔TRUE	The switch-on inhibit is deactivated and the controller changes to the device state "Device is switched on".				

## Outputs

Identifier DIS code   data type	Value/meaning
DI_dnState <a href="#">C02547</a>   DINT	Status (bit coded)
	<b>Status signals of the currently enabled basic function (if available):</b>
	Bit 0 -
	Bit 1 Basic function is active (signal <i>bActive</i> ).
	Bit 2 Basic function is completed (signal <i>bDone</i> ).
	Bit 3 Acceleration/deceleration phase is active (signal <i>bAccDec</i> ).
	Bit 4 -
	Bit 5 CCW rotation is active (signal <i>bCcw</i> ).
	Bit 6 -
	Bit 7 Reference known.
	Bit 8 Brake is open.
	Bit 9 Waiting for clutch condition.
	Bit 10 Zero crossing detected or position = "0".
	Bit 11 -
	Bit 12 -
	Bit 13 -
	Bit 14 -
	Bit 15 Fault in active basic function (group signal).
	<b>Status signals of the internal state machine for the basic functions:</b>
	Bit 16 <a href="#">Torque follower</a> active.
	Bit 17 <a href="#">Speed follower</a> active.
	Bit 18 <a href="#">Position follower</a> active.
	Bit 19 Setpoint follower is active (group signal for bit 16 ...18).
	Bit 20 <a href="#">Positioning</a> active.
	Bit 21 <a href="#">Homing</a> active.
	Bit 22 <a href="#">Manual jog</a> active.
	Bit 23 Brake test is active.
	Bit 24 Drive at standstill.
	Bit 25 Drive is stopped.
	Bit 26 <a href="#">Quick stop</a> active.
	Bit 27 -
	Bit 28 Controller is not ready.
Bit 29 Initialisation	
Bit 30 State "Fault active" (signal <i>DI_bFailActive</i> ).	
Bit 31 State machine is not ready to receive setpoints. (Group signal for bit 28 ... 30)	
DI_bReady <a href="#">C02549/6</a>   BOOL	Status signal "controller is ready for operation" TRUE The controller is ready for operation.
DI_bFailActive <a href="#">C02549/7</a>   BOOL	Status signal "Error active - acknowledgement required" TRUE Monitoring with the "Fault" or "Quick stop by trouble" error response has responded and the controller is in the device state "Fault active" or "Quick stop by trouble active". For exiting the device state the fault has to be acknowledged, e. g. via the input <i>DI_bErrorReset1...3</i> .

Identifier DIS code   data type	Value/meaning
DI_bImpActive <a href="#">C02549/8</a>   BOOL	Status signal "Pulse inhibit set" TRUE   The power output stages are switched to high impedance.
DI_bClnhActive <a href="#">C02549/9</a>   BOOL	Status signal "Controller inhibit active" TRUE   The controller inhibit is active.
DI_bWarningActive <a href="#">C02549/10</a>   BOOL	Status signal "Warning active" TRUE   There is a warning in the drive controller.
DI_bUVDetected <a href="#">C02549/11</a>   BOOL	Status signal "Undervoltage detected" • The threshold for this monitoring function depends on the setting under <a href="#">C00173</a> . TRUE   Undervoltage detected in DC bus.
DI_bOVDetected <a href="#">C02549/12</a>   BOOL	Status signal "Overvoltage detected" • The threshold for this monitoring function depends on the setting under <a href="#">C00173</a> . TRUE   Overvoltage detected in DC bus.
DI_bMainSupplyOk <a href="#">C02549/13</a>   BOOL	Status signal "Mains voltage is applied" TRUE   A voltage is applied to the mains voltage inputs L1, L2 and L3.
DI_bReadyToSwitchOn <a href="#">C02549/14</a>   BOOL	Status signal "Controller ready to switch on" TRUE   The controller has completed the initialisation and is in the "Device is ready to switch on" device state.
DI_bOperationEnabled <a href="#">C02549/15</a>   BOOL	Status signal "Operation is enabled" TRUE   The controller is in the "Operation" device state and the motor follows its setpoint according to the selected basic drive function or is at standstill due to stop or quick stop.
DI_dwErrorCode DWORD	Error number of the current error message ▶ <a href="#">Error messages of the operating system</a> (□ 620)
DI_AxisData	Data structure, which contains all required machine constants.

4.7.1 Status signals

The following representation shows which status signals of the drive interface are set to TRUE in different typical cases:

**Case 1:**  
Application has been transmitted to the controller.  
No mains voltage available (LU fault).  
Controller is inhibited (via RFR terminal).

**Case 2:**  
Mains voltage has been connected.

**Case 3:**  
Controller inhibit has been deactivated.

**Case 4:**  
Error active.

**Case 5:**  
Quick stop by trouble is active

Status	Case 1	Case 2	Case 3	Case 4	Case 5	Status signal (output)
Ready for operation	●	●	●	●	●	DI_bReady
Fault active	●	●	●	●	●	DI_bFailActive
Pulse inhibit active	●	●	●	●	●	DI_bImpActive
Controller inhibit active	●	●	●	●	●	DI_bClnhActive
Warning is active	●	●	●	●	●	DI_bWarningActive
Undervoltage detected	●	●	●	●	●	DI_bUVDetected
Overvoltage detected	●	●	●	●	●	DI_bOVDetected
Mains supply is ok	●	●	●	●	●	DI_bMainSupplyOk
Ready to switch on	●	●	●	●	●	DI_bReadyToSwitchOn
Operation enabled	●	●	●	●	●	DI_bOperationEnabled

### 4.7.2 Monitoring of external events

Use the input *DI\_bSetExternError* of the [LS\\_DriveInterface](#) system block to monitor external events by means of corresponding logic operations and activate the error message "External error" in the controller.

#### Parameterising a response to an external error

The controller response to the error message "External error" can be selected under [C00581](#).

#### Activation of "External error" error message

The error message "External error" is activated by setting the input *DI\_bSetExternError* to TRUE.

- After this, the error number for the error message "External error" "[0x20750000](#)" (when "Fault" has been selected as response) will be stored in the internal fault memory ([C00168](#)).

#### Reset error message

The error message "External error" and other active error messages are reset by setting the input *DI\_bResetError* to TRUE.

- If the input *DI\_bSetExternError* is still set to TRUE, the reset will not be carried out.
- Error messages can only be reset if the cause of the error has been eliminated.

### 5 Motor interface

This chapter provides you with information on initial commissioning of the motor and the parameterisation of the internal motor control of the controller.



#### Note!

The motor interface contains all control functions that are not provided by other basic drive functions.

To select application-specific setpoints, the motor interface can be extended by appropriate interfaces using the basic functions "[Speed follower](#)", "[Torque follower](#)" and "[Position follower](#)".

The application-specific conditioning of the encoder signals is executed with the basic function "[Encoder evaluation](#)".



## How to get to the dialog for setting the motor interface parameters:

1. Go to the *Project view* of the »Engineer« and select the 9400 HighLine controller.
2. Select the **Application parameters** tab from the *Workspace*.
3. Click the following button of the *Overview* dialog level:

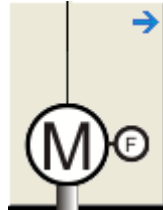

## Parameterisation dialog in the »Engineer«

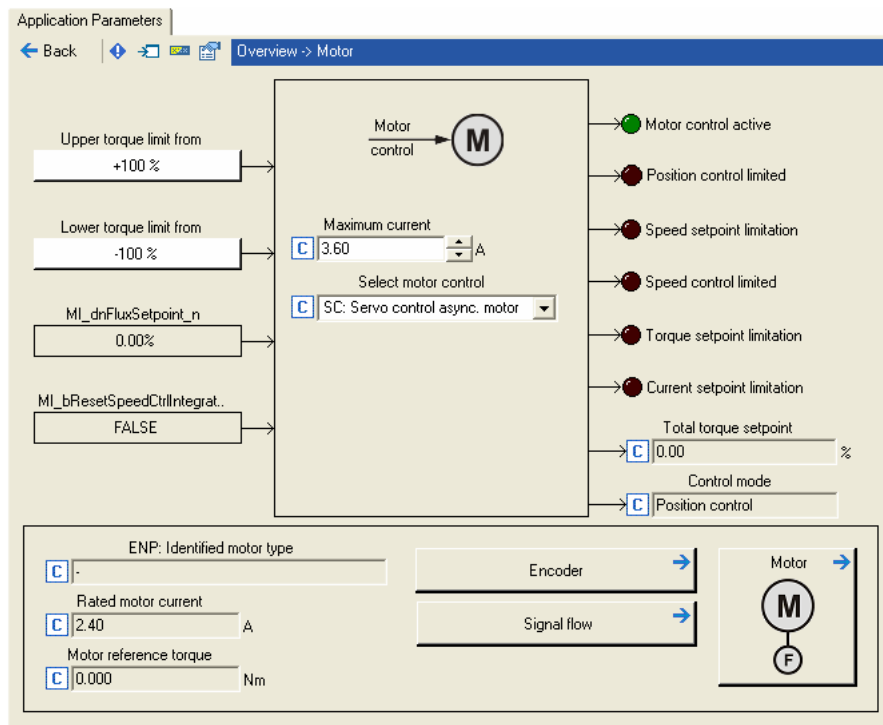

- The white buttons indicate the configuration of the motor interface inputs. ▶ [Internal interfaces | "LS\\_MotorInterface" system block \(234\)](#)
  - The configuration is predefined by the technology application selected (in this example "Actuating drive – speed"). If required, this configuration can be changed by clicking the corresponding buttons.
- If you click a button marked with the → symbol, you go one level deeper in the corresponding parameterisation dialog.

# 5 Motor interface

## 5.1 General information

---

### 5.1 General information

#### 5.1.1 Reading out motor data from the controller

If the Lenze motor connected to the controller has an electronic nameplate (ENP), the motor does not need to be selected in the »Engineer« motor catalogue.

- With the first switch-on of the controller all motor data are automatically read out from the electronic nameplate of the motor and at first are saved temporarily within the controller.
- For a permanent acceptance of the motor data, the parameter set must be saved ([C00002](#) = "11: Save start parameters").
- If there is an online connection between »Engineer« and the controller, the motor data can be accepted from the controller to the »Engineer« project.



#### How to read out the motor data from the controller:

1. Establish an online connection between »Engineer« and controller.
2. Select the **Application parameters** tab and change to the *Overview* → *Motor* → *Motor* dialog level.
3. Click on the **From Drive** button.
  - Then the motor data are read out of the controller and directly written into the corresponding codes of the »Engineer« project.

#### Display parameters for electronic nameplate (ENP)

Parameters	Info	Lenze setting	
		Value	Unit
<a href="#">C00186</a>	ENP: Identified motor type	-	
<a href="#">C00187</a>	ENP: Identified serial number	-	
<a href="#">C00188</a>	ENP: Status	-	



### 5.1.2 Selecting a motor from the motor catalogue in the »Engineer«

If the Lenze motor does not have an electronic nameplate (ENP) or if a motor of a third-party manufacturer is used, select the motor in »Engineer« via the motor catalogue and transfer the motor data to the controller.

- If a checkmark is set in the **Motor** control field in the "Other components" dialog when the controller is inserted into the project, the motor for the controller can be selected from the motor catalogue in another dialog:

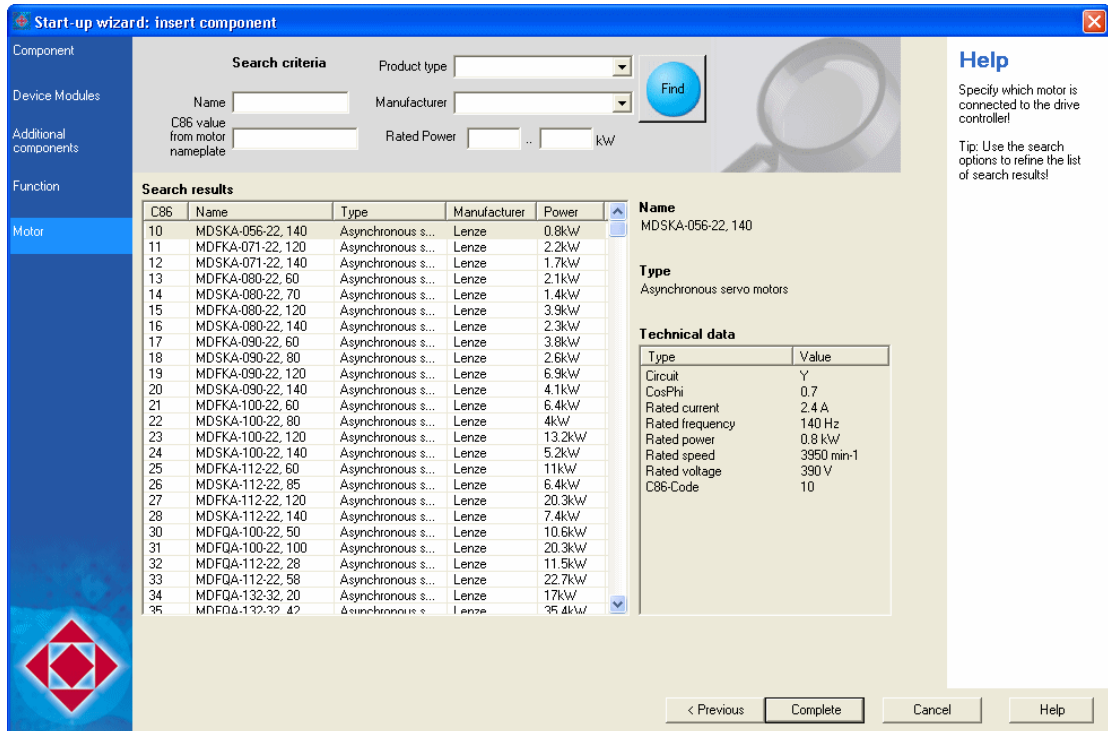

- Alternatively, the motor can be inserted into the project at a later time via the **Insert a component** command.



**Tip!**

If a third party manufacturer's motor is used, select a Lenze motor from the motor catalogue first which is similar in terms of current, voltage and speed rating. Adapt the preselected motor data exactly to the real motor afterwards.

▶ [Displaying/editing motor data in »Engineer«](#) (122)

### 5.1.3 Displaying/editing motor data in »Engineer«

The term "Motor data" combines all parameters that only depend on the motor. They solely characterise the electrical behaviour of the machine.

- The motor data do not depend on the application in which the controller and motor are used.
- The motor data are, if available in »Engineer« via electronic nameplate or motor catalogue, accepted by the controller without confirmation prompt.

In »Engineer« the motor data are shown on the **Application parameters** tab in the dialog level *Overview*→*Motor*→*Motor*:

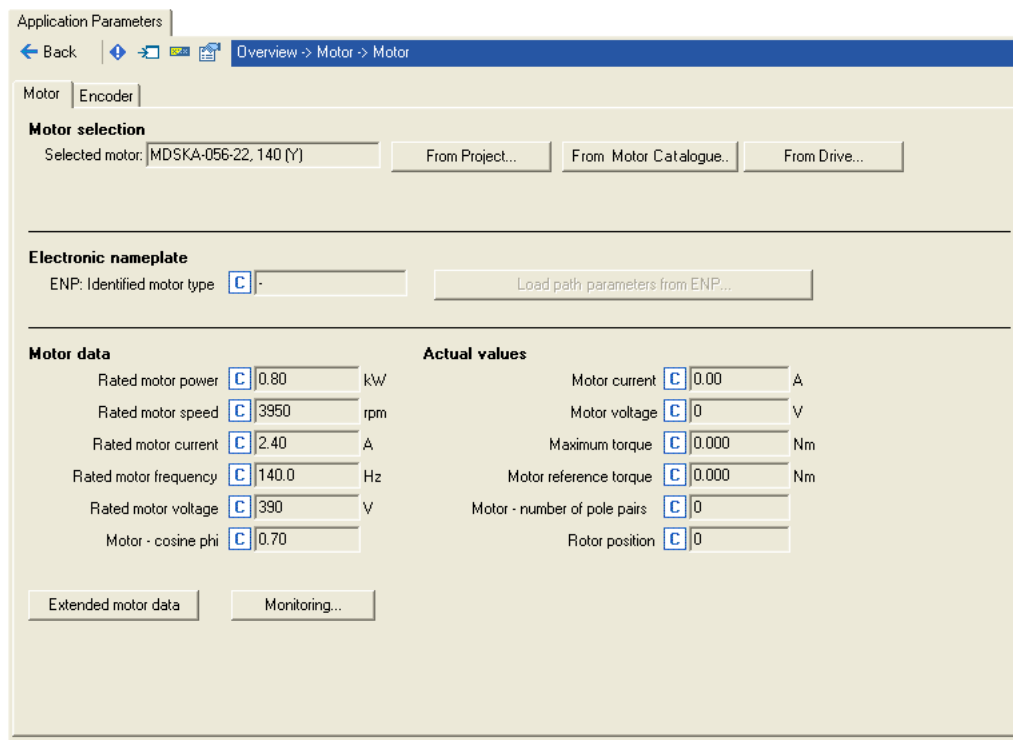

- If you use a motor of a third-party manufacturer, the displayed motor data can be adapted exactly to the existing motor by clicking the **From Project** button and then selecting the "Own motor settings" entry in the **Motor selection** dialog box.
- Via the **From Motor Catalogue** button, the motor catalogue can be opened to select another motor. ▶ [Selecting a motor from the motor catalogue in the »Engineer«](#) (121)
- If an online connection has been established, the motor data set in the controller can be accepted in »Engineer« via the button **From Drive**. ▶ [Reading out motor data from the controller](#) (120)

# 5 Motor interface

## 5.1 General information

### Overview of motor data

Parameters	Info	Lenze setting *	
		Value	Unit
<a href="#">C00052</a>	Motor voltage	-	V
<a href="#">C00054</a>	Motor current	-	A
<a href="#">C00057/1</a>	Maximum torque	-	Nm
<a href="#">C00057/2</a>	Motor reference torque	-	Nm
<a href="#">C00059</a>	Motor - number of pole pairs	-	
<a href="#">C00060</a>	Motor pole angle	-	
<a href="#">C00079</a>	Motor magnetising inductance	-	mH
<a href="#">C00081</a>	Rated motor power		kW
<a href="#">C00082</a>	Motor rotor resistance	-	Ohm
<a href="#">C00083</a>	Motor rotor time constant	-	ms
<a href="#">C00084</a>	Motor stator resistance		Ohm
<a href="#">C00085</a>	Motor stator leakage inductance		mH
<a href="#">C00087</a>	Rated motor speed		rpm
<a href="#">C00088</a>	Rated motor current		A
<a href="#">C00089</a>	Rated motor frequency		Hz
<a href="#">C00090</a>	Rated motor voltage		V
<a href="#">C00091</a>	Motor cosine phi		
<a href="#">C00092</a>	Motor magnetising current	-	A
<a href="#">C00128/1</a>	Therm. time constant coil		min
<a href="#">C00128/2</a>	Therm. time constant plates		min
<a href="#">C00273/1</a>	Motor moment of inertia		kg cm <sup>2</sup>
<a href="#">C01190</a>	Motor thermal sensor		
<a href="#">C01191/1</a>	Spec. characteristic: temperature		°C
<a href="#">C01191/2</a>	Spec. characteristic: temperature		°C
<a href="#">C01192/1</a>	Spec. characteristic: resistance		Ohm
<a href="#">C01192/2</a>	Spec. characteristic: resistance		Ohm

Greyed out = display parameter

\* depending on the selected motor type



### Note!

If the motor has been selected via the »Engineer« motor catalogue, or if the motor data have been adapted offline in »Engineer«, all motor data have to be transferred to the controller afterwards when an online connection has been established and have to be saved in the memory module with mains failure protection (device command [C00002](#) = "11: Save start parameters").

# 5 Motor interface

## 5.2 Select motor control

### 5.2 Select motor control

In [C00006](#) the motor control is selected; the default is the servo control for synchronous motors.

#### Function extension from software version V3.0:

From software version V3.0, alternatively to the servo control also the V/f control and the sensorless vector control are provided as control types in [C00006](#):

Open/closed loop control	Detailed information
1 SC: Servo control for synchronous motor	▶ <a href="#">Servo control (SC)</a> (📖 145)
2 SC: Servo control for asynchronous motor	
4 SLVC: sensorless vector control	▶ <a href="#">Sensorless vector control (SLVC)</a> (📖 166)
6 VFCplus: V/f control open loop	▶ <a href="#">V/f control (VFCplus)</a> (📖 184)
7 VFCplus: V/f control closed loop	▶ <a href="#">V/f control (VFCplus)</a> (📖 200)

- The V/f control is the classic operating mode for standard applications.
- Compared to the V/f control, improved drive characteristics can be achieved with sensorless vector control by:
  - a higher torque across the entire speed range
  - a higher speed accuracy and a higher concentricity factor
  - Higher efficiency

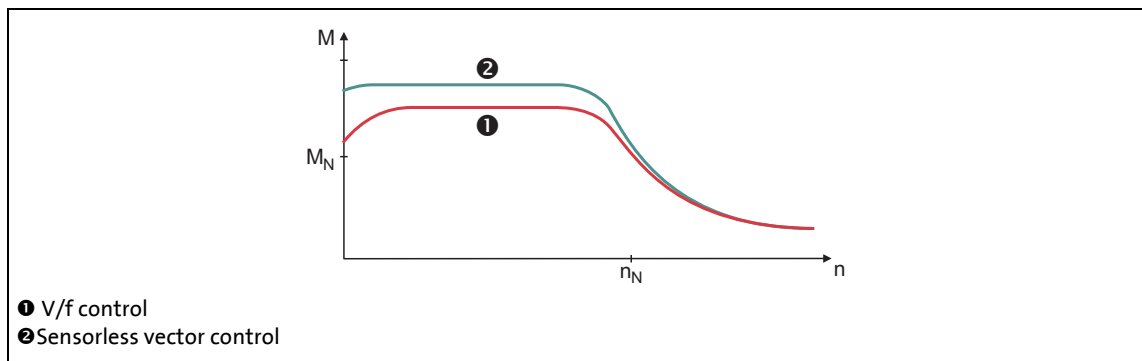

[5-1] Comparison of V/f control and sensorless vector control



#### Note!

Sensorless vector control (SLVC) is only approved for powers up to 55 kW and horizontal applications (no hoists or lifting equipment)!

# 5 Motor interface

## 5.2 Select motor control

For the V/f control and sensorless vector control the following table helps with the selection of the correct control type:

	Selection of the motor control in <a href="#">C00006</a>			
	Motor cable shielded ≤ 50 m unshielded ≤ 100 m		Motor cable shielded > 50 m unshielded > 100 m	
	recommended	Alternatively	recommended	Alternatively
<b>Single drives</b>				
With motor filter	6 / 7	-	6 / 7	-
With constant load	4	6 / 7	6 / 7	-
With extremely alternating loads	4	6 / 7	6 / 7	-
With high starting duty	4	6 / 7	6 / 7	-
Positioning and infeed drives	4	6 / 7	6 / 7	-
Winders/unwinders dancer	6 / 7	-	6 / 7	-
Pump and fan drives *	6 / 7	-	6 / 7	-
Three-phase reluctance motors	6 / 7	-	6 / 7	-
Three-phase sliding rotor motors	6 / 7	-	6 / 7	-
Three-phase AC motors with firmly assigned voltage/frequency characteristic	6 / 7	-	6 / 7	-
Vertical drive/hoist (up to 55 kW)	6 / 7 (with VCC**)	-	6 / 7 (with VCC**)	-
* For this application, we recommend a square-law voltage characteristic ( <a href="#">C00950</a> = "1") ** VCC = <a href="#">voltage vector control</a>				
<b>Group drives</b> Depending on the resulting motor cable length:				
$l_{res} = \sqrt{i} \cdot (l_1 + l_2 + \dots + l_i)$				
Identical motors and loads	4	6 / 7	6 / 7	-
Different motors and/or alternating loads	6 / 7	-	6 / 7	-



### Note!

For operation with motor encoder, we recommend to use the servo control!  
For operation with motor filter, always use the V/f control!

### 5.3 Adjusting motor and controller to each other

This "initial commissioning" of the motor is required if no motor data suitable for the application is available yet in the memory module of the controller and in the »Engineer« project .

- The following step-by-step instructions can be used as a "check list" to correctly adjust the motor and controller to each other.
- Detailed information on the individual steps can be found in the following subchapters.

Worksteps		Motor control*		
		SC	SLVC	VFC plus
1	<a href="#">Accepting/adapting plant parameters.</a> (☞ 127)	●	●	●
2.	<a href="#">Parameterising motor encoder.</a> (☞ 129) • Only required for the control types with speed feedback (servo control and V/f control).	●		(●)
3	<a href="#">Pole position identification.</a> (☞ 131) • Only required: • For servo control with synchronous motor of a third-party manufacturer. • For servo control with synchronous motor and use of incremental encoders (TTL or sin/cos encoders as well as multi-pole pair resolvers). • After changes of the motor feedback system, e.g. encoder exchange.	(●)		
4	<a href="#">Optimising the switching performance of the inverter.</a> (☞ 138) • Only required for servo control if the motor parameters are to be defined by a motor from a third-party manufacturer! • Always required for sensorless vector control and open loop V/f control! • An optimum drive performance can only be achieved with the sensorless operating modes if the voltage errors in the inverter are compensated as exactly as possible.	(●)	●	●
5	<a href="#">Determining the motor parameters.</a> (☞ 141) • Only required for servo control if the motor parameters are to be defined by a motor from a third-party manufacturer! • Always required for sensorless vector control! • An optimum drive performance can only be achieved with the sensorless vector control if the motor parameters correspond to the real motor as exactly as possible.	(●)	●	

\* SC = servo control    SLVC = sensorless vector control    VFCplus = V/f control

### 5.3.1 Accepting/adapting plant parameters

The "plant parameters" summarise all parameters which result from the combination of motor and load. These characterise the transfer behaviour of the entire controlled system including the required monitoring modes.

- The plant parameters depend on the application in which the controller and motor are used.
- When a Lenze motor is selected in the »Engineer«, plant parameters are suggested for this motor for a load-free operation.

#### Overview of plant parameters

Parameters	Info	Lenze setting		Motor control*		
		Value	Unit	SC	SLVC	VFC plus
<a href="#">C00011</a>	Reference speed motor	3000	rpm	●	●	●
<a href="#">C00022</a>	Maximum current	0.00	A	●	●	●
<a href="#">C00070</a>	Speed controller gain	0.500	Nm/rpm	●	●	● <sup>1</sup>
<a href="#">C00071</a>	Speed controller reset time	24.0	ms	●	●	● <sup>1</sup>
<a href="#">C00072</a>	Speed controller rate time	0.00	ms	●		
<a href="#">C00497</a>	Speed act. val. time const.	2.0	ms	●	●	●
<a href="#">C00596</a>	Threshold max. speed reached	6500	rpm	●	●	●

\* SC = servo control    SLVC = sensorless vector control    VFCplus = V/f control open loop    <sup>1</sup> Only for V/f control closed loop



#### Note!

If plant data have been adapted offline in »Engineer«, all plant data have to be transferred to the control afterwards when an online connection has been established and have to be saved in the memory module with mains failure protection (device command [C00002](#) = "11: Save start parameters").

**Reference speed motor**

In [C00011](#) the reference speed of the motor must be set.

**Note!**

From the perspective of the application it has to be ensured that a maximum of 100 % of the reference speed set in [C00011](#) is requested as speed setpoint.

**When using MCS motors, please observe the following:**

The controller with software version V01.xx does not support a field weakening control for synchronous motors, so that for this version the operation of MCS motors at the voltage limit may present an undefined behaviour.

Therefore it should be detected whether the motor used exceeds the voltage limit within the desired operating range up to the maximum current/reference speed. If so, the reference speed must be reduced to a value permissible with regard to voltage.

**Maximum current**

In [C00022](#) the required maximum current must be set.

- To avoid that the motor starts unintentionally without adjusting the plant data, the maximum current in the Lenze setting is set to "0 A" in [C00022](#).

**Ultimate motor current  $I_{ULT}$** 

[C00620](#) serves to check the set ultimate motor current  $I_{ULT}$ .

**Note!**

When you select a Lenze motor from the catalogue and transfer the plant parameters of the motor to the controller, the setting in [C00620](#) is automatically adjusted to the selected motor.

The ultimate motor current  $I_{ULT}$  is a limit value to protect the motor from destruction or influence of the rated data.

- This limit value must not be travelled cyclically in the drive process.
- The maximum current parameterisable in [C00022](#) should have a sufficient distance from this limit value.
- If the instantaneous value of the motor current exceeds the limit value set in [C00620](#) the response set in [C00619](#) is executed for motor protection (Lenze setting: Fault).

**Maximum motor speed**

Adapt the maximum motor speed in [C00596](#) and select the error response required when this speed limit has been reached in [C00607](#).



## 5.3.2 Parameterising motor encoder

**Note!**

Only required for servo control and closed loop V/f control!

**Tip!**

Detailed information on the encoder evaluation and on the use of a separate position encoder can be found in the following main chapter "[Encoder evaluation](#)". (📖 239)

- The motor encoder can be parameterised on the **Application parameters** tab of »Engineer« in the *Overview* → *Motor* → *Encoder* dialog level.
- The following table shows the required settings for different encoder types:

Encoder type:	Resolver Tamagawa	CDD50	ITD21	ITD22	SEK... SEL...	SKS... SKM...	SCS70 SCM70	SRS50 SRM50	ECN1313 EQN1325	EQI1329
Motor type:	MCS MCA MDxKS MDXMA	MCA	MDFQA LMR	MDFQA LMR			MDxKS	MCS MCA	MCS MCA	MCS MCA
<a href="#">C00495</a> Motor encoder selection	0 Resolver	1 Encoder								
<a href="#">C00080</a> Number of resolver pole pairs	1	-	-	-	-	-	-	-	-	-
<a href="#">C00422</a> Encoder type	-	0 Incremental encoder (TTL signal)	1 Sin/cos encoder	2 Absolute value encoder (Hiperface)				3 Absolute value encoder (EnDat)		
<a href="#">C00420</a> Number of encoder increments	-	2048		16	128	512	1024	2048	32	
<a href="#">C00421</a> Encoder voltage	-	5 V			8 V				5 V	

**Danger!**

If the encoder/resolver is used as motor encoder:  
In case of error, safe operation of the motor is no longer guaranteed!

When servo control is used:

- For the (open circuit) monitoring of the encoder/resolver for reasons of safety always the "Fault" response (Lenze setting) should be set!

When V/f control is used:

- For this type of motor control, the drive basically is to coast down after an encoder failure and may not stop, therefore the "Warning" response is to be set for the (open circuit) monitoring in this case!

---

**Short overview: Parameters for setting the response to (open circuit) monitoring**

Parameters	Info	Lenze setting
<a href="#">C00580</a>	Resp. to encoder open circuit	Error
<a href="#">C00586</a>	Resp. to resolver open circuit	Error
<a href="#">C00601</a>	Resp. to encoder comm. error	Error

### 5.3.3 Pole position identification



#### Note!

Only required:

- For servo control with synchronous motor of a third-party manufacturer.
- For servo control with synchronous motor and use of incremental encoders (TTL or sin/cos encoders as well as multi-pole pair resolvers).
- After changes of the motor feedback system, e.g. encoder exchange.

For the control of permanent-magnet synchronous machines, the pole position – the angle between the motor phase U and the field axis of the rotor – must be known.

- For Lenze motors with absolute value encoder or resolver, the pole position is already set correctly in [C00058/1...3](#).
- When incremental encoders (TTL or sin/cos encoders) are used, a pole position identification (PPI) is always required after mains switching, even with Lenze motors.
- The controller can also evaluate multi-pole-pair resolvers.
  - When the number of motor pole pairs is an integer multiple of the number of pole pairs of the resolver, a pole position identification must only be executed once.
  - When the number of motor pole pairs is no integer multiple of the number of pole pairs of the resolver, a pole position identification must be executed after every mains switching.
- The device commands "Identify pole position (360°)" and "Identify pole position (min. motion)" serve to determine the pole position for the motor encoder currently activated in [C00495](#) (see the following instructions).



#### Danger!

The machine must not be braked or blocked during the pole position identification! For this reason, the pole position identification is not permitted for hanging loads!

During the pole position identification the rotor aligns itself. The motor shaft moves by max. one electrical revolution which causes the corresponding movement of the connected mechanical components!



#### Stop!

Check the correct parameterisation of the max. motor current monitoring ([C00619](#) and [C00620](#)) before carrying out the pole position identification to prevent the motor from being permanently damaged.

**Note!**

As of software version V4.0:

If the pole position identification is aborted, the response parameterised in [C00640](#) is activated (Lenze setting: "Fault").

- Pay attention to this changed behaviour in the Lenze setting when updating the firmware of existing systems!
- If this behaviour is not wanted, deactivate the monitoring by selecting "0: No response" in [C00640](#).

The pole position identification can be adjusted to the respective machine and the prevailing moments of inertia by means of parameters.

- In the Lenze setting of the parameters, the pole position identification remains the same as in software versions < V4.0.

▶ [Adjustment of the pole position identification](#) (135)

**How to execute the pole position identification:**

1. If the controller is enabled, inhibit the controller, e. g. with the device command [C00002](#) = "41: Inhibit controller".
2. Execute device command [C00002](#) = "51: Identify pole position (360°)" or

device command [C00002](#) = "52: Identify pole position (min. motion)".

The procedure starts with controller enable, if

- a synchronous machine is selected,
- no other identification is active,
- no error has occurred, and
- no test mode is activated.

If one of the above conditions is not met, the procedure is cancelled and the corresponding device command status is indicated under [C00003](#).

**Note:**

By means of controller inhibit, the procedure started can be cancelled anytime, if required, without carrying out a change in [C00058](#).

For detailed information about the corresponding procedure, please see the following sections:

**Tip!**

For controller enable all sources for controller inhibit must be reset. In [C00158](#) the sources for controller inhibit are displayed in a bit-coded manner.

The status of the device command activated under [C00002](#) is indicated under [C00003](#).

**Procedure for "pole position identification 360°"**

If all conditions are met, the motor is energised with a direct current corresponding to the lower of the following two values:

$\sqrt{2} \cdot \text{Rated device current}$ or $\sqrt{2} \cdot \text{Rated motor current}$
---

- The rotor is aligned through the current flow. This is absolutely necessary for the procedure.
- To ensure that the torque-neutral axis is not accidentally energised and the rotor stops, a 45° current vector is (electrically) generated for a short instant and then (electrically) switched back to 0° (≡ phase U).
  - Then a DC current of the above-mentioned value could be measured in this motor phase.

The next steps of the procedure depend on the feedback system used:

- If an absolute value encoder with Hiperface or EnDat protocol is used, the encoder position is set to zero and the procedure is cancelled.
- If a resolver or an optical encoder without absolute track is used, the difference between the preselected current angle and the mechanical rotor angle is determined. After this, the current vector is (electrically) turned by another 22.5° and the difference between current angle and rotor angle is determined once again.
  - The procedure is repeated 16 times. This corresponds to one electrical revolution. The machine rotates by 360° (mech.)/pole pair number.
  - Take the average value of the 16 measurements to compensate for asymmetries.

**Procedure for "pole position identification with minimal movement"**

If all conditions are met, the motor current is increased step by step to the smaller of the following two values:

$25 \% \cdot \sqrt{2} \cdot \text{Rated device current}$ or $25 \% \cdot \sqrt{2} \cdot \text{Rated motor current}$
---

- By the current flow the rotor aligns itself, which, however, is compensated by a position control.
- If the rotor moves electrically by more than 20°, a fault message is output and the value measured is rejected. This may occur in the case of motors with a noticeable detent torque.
- In order to detect a non-permissible blocking of the machine, a positive and negative test angle ( $\pm 20^\circ$ ) relative to the current position are defined after the identification. The machine must align itself to these two test angles within a tolerance of 25 %.

**Note!**

In this procedure it is not written back into an optical absolute value encoder and all feedback systems are treated the same way.

Unlike in the "pole position identification 360°" procedure where, when an optical absolute value encoder is used, a "0" is entered into the encoder and into [C00058/2](#), for this procedure nothing needs to be entered into the encoder and the identification result is entered into [C00058/2](#).

---

**After successful completion...**

...the controller is inhibited automatically and the pole position determined for the activated feedback system is set in the corresponding subcode of [C00058](#).

- For a permanent acceptance of the identified pole position, the parameter set must be saved ([C00002](#) = "11: Save start parameters").
- The next controller inhibit and subsequent controller enable serve to cancel the controller inhibit automatically set by the procedure (e.g. by first executing the device command [C00002](#) = "41: Inhibit controller" and then executing the device command [C00002](#) = "42: Enable controller").

**In the event of an error**

If an error occurs during the procedure or the pulse inhibit gets active (e.g. due to short-time undervoltage), the procedure is terminated with controller inhibit without making a change in [C00058](#).

If the machine was braked or blocked during the procedure, this will be recognised at the end of the measurement and no change is made in [C00058](#).

As of software version V4.0, the response parameterised in [C00640](#) (Lenze setting: "Fault") is triggered and the error message "Pole position identification cancelled" is entered in the logbook of the controller if the pole position identification process is aborted.

**Tip!**

From software version V7.0 onwards, the pole position identification is additionally available as a basic function in the form of the [LS\\_PolePositionIdentification](#) system block.

Basic drive functions: ▶ [Pole position identification](#) (📖 575)

### 5.3.3.1 Adjustment of the pole position identification

This function extension is available from software version V4.0!

The two procedures for [Pole position identification](#) (PPI) described in the previous sections can be adjusted to the respective machine and the prevailing moments of inertia by means of the parameters described below.

In the Lenze setting of the parameters, the pole position identification remains the same as in software versions < V4.0.



#### Note!

The two procedures for the pole position identification should give the same results. But, due to e.g. friction, bearing forces and a trapezoidal field pattern, the results may differ. A proportional increase of the current amplitude in [C00641](#) or [C00646](#) can counteract this deviation.

#### Parameters for the pole position identification 360°

Parameters	Info	Lenze setting	
		Value	Unit
<a href="#">C00641</a>	PLI 360° current amplitude	100	%
<a href="#">C00642</a>	PLI 360° ramp time	100	%
<a href="#">C00643</a>	PLI 360° traversing direction	Clockwise rotating field	
<a href="#">C00644</a>	PolePosId 360° fault tol.	0	°

- The current amplitude can be adjusted proportionally in [C00641](#).
  - For large machines and high mass inertia values or for linear direct drives, the current amplitude usually has to be increased.
  - The Lenze setting "100 %" corresponds to the smaller of the two following values:

$$\sqrt{2} \cdot \text{Rated device current}$$

or

$$\sqrt{2} \cdot \text{Rated motor current}$$



#### Stop!

If there is no temperature monitoring in the motor and/or the  $I^2xt$  motor monitoring and the maximum current monitoring are not parameterised correctly, the motor might be damaged permanently when the current amplitude is set too high (e.g. to the maximum value!

- ▶ [Motor monitoring \( \$I^2xt\$ \)](#) (☞ 218)
- ▶ [Maximum current monitoring](#) (☞ 233)

**Note!**

If the current amplitude is set to 100 % in [C00641](#) >, the device utilisation (Ixt) monitoring and/or one of the motor monitoring functions may respond and cause the abort of the pole position identification.

- The ramp time can be adjusted proportionally in [C00642](#).
  - For large machines and high mass inertia values, the ramp time usually has to be increased.
  - For small machines, a reduction of the ramp time can speed up the pole position identification process.
- In some situations it may be helpful to reverse the travel direction ([C00643](#)) for the pole position identification (e.g. for linear motor at the end stop).
- The "pole position identification 360°" procedure comprises a plausibility check. If the rotor position determined via the encoder system does not correspond to the controlled output position:
  - the pole position identification procedure is aborted.
  - the response parameterised in [C00640](#) (Lenze setting: "Fault") is activated.
  - the error message "Pole position identification cancelled" is entered into the logbook of the controller.
- The preset fault tolerance for the plausibility check can be changed via [C00644](#).

**Parameters for the pole position identification with minimal movement**

Parameters	Info	Lenze setting	
		Value	Unit
<a href="#">C00646</a>	PLI min. motion current amplitude	100	%
<a href="#">C00647</a>	PolePosId min.mov. cur.rise rate	100	%
<a href="#">C00648</a>	PolePosId min.mov. gain Vp	0	
<a href="#">C00649</a>	PolePosId min.mov. reset time Tn	62.5	ms
<a href="#">C00650</a>	PLI min. motion max. perm. motion	20	°

- The current amplitude can be adjusted proportionally in [C00646](#).
  - For large machines and high mass inertia values or for linear direct drives, the current amplitude usually has to be increased.
  - The Lenze setting "100 %" corresponds to the smaller of the two following values:

$$25 \% \cdot \sqrt{2} \cdot \text{Rated device current}$$

or

$$25 \% \cdot \sqrt{2} \cdot \text{Rated motor current}$$



**Stop!**

If there is no temperature monitoring in the motor and/or the  $I^2xt$  motor monitoring and the maximum current monitoring are not parameterised correctly, the motor might be damaged permanently when the current amplitude is set too high (e.g. to the maximum value!

- ▶ [Motor monitoring \( \$I^2xt\$ \)](#) (📖 218)
- ▶ [Maximum current monitoring](#) (📖 233)

**Note!**

If the current amplitude is set to 400 % in [C00646](#) >, the device utilisation ( $Ixt$ ) monitoring and/or one of the motor monitoring functions may respond and cause the abort of the pole position identification.

- The rate of the current rise for the pole position identification can be adjusted proportionally in [C00647](#). The Lenze setting "100 %" corresponds to the fixed rise rate setting of the software versions < V4.0.
- The P component of the PI controller for the pole position identification can be adjusted in [C00648](#). With the Lenze setting "0", the PI controller continues to work as an I controller (as in the previous software versions).
- The I component of the PI controller for the pole position identification can be adjusted in [C00649](#). Please observe the following notes:
  - The variable *Position.dnActualMotorPos* can be used to monitor the deviation of the position from the start position with the [Oscilloscope](#) function in »Engineer«.
  - In order to be able to compensate a position deviation faster, first the reset time in [C00649](#) should be reduced. If this does not result in the desired behaviour, the proportional gain can be increased in [C00648](#).
  - Ensure that the position control does not get unstable. We therefore recommend to use an I controller.
- The pole position identification comprises a monitoring function for the follow-up control. If a movement greater than the permissible movement set in [C00650](#) is detected by the encoder system:
  - the pole position identification procedure is aborted.
  - the response parameterised in [C00640](#) (Lenze setting: "Fault") is activated.
  - the error message "Pole position identification cancelled" is entered into the logbook of the controller.
- In order to detect a non-permissible blocking of the machine, a positive and negative test angle relative to the current position are defined after the identification. The machine must align itself to these two test angles within a tolerance of 25 %. The size of the test angle corresponds to the max. permissible movement set in [C00650](#).

### 5.3.4 Optimising the switching performance of the inverter



#### Note!

Only required for servo control if the motor parameters are to be defined by a motor from a third-party manufacturer!

Always required for sensorless vector control and open loop V/f control!

- An optimum drive performance can only be achieved with the sensorless operating modes if the voltage errors in the inverter are compensated as exactly as possible.

An inverter generates a pulse-width-modulated, three-phase voltage system. Due to the design of the inverter, current-dependent and switching frequency-dependent losses inside of the inverter falsify the voltage that is output. As the voltage that is output is not measured, the losses have to be compensated by a suitable feedforward control. This compensation is based on an inverter error characteristic.

Among other things, the inverter error characteristic depends on the length of the motor cable and at least has to be individually determined once for the connected motor by means of the device command "Calculate inv. characteristic". For an automatic determination of the motor parameters, this ensures that the current has a sinusoidal form.



#### Danger!

This procedure may only be carried out during commissioning, not during operation!

- During the procedure the motor is energised so that:
  - it cannot be excluded that the connected mechanical components may move!
  - the windings heat up.
 If you repeat the procedure, ensure that the motor is not thermally overloaded (particularly if no temperature feedback is used).

For software versions lower than V4.0 the following applies:

- If the automatic brake operation is used, ensure that no basic function is requested or that the application is stopped before this procedure is called. Otherwise the applied holding brake could be released!
- For positioning applications you have to observe that the absolute position and the home position will get lost when this procedure is called. The loss of the home position is not signalled to the application. The following sequence has to be observed for positioning applications: 1.) Execute identification → 2.) Save parameter set → 3.) Restart controller → 4.) Execute homing procedure.



#### Note!

For devices of the types 6 + 7 the Ixt monitoring may be activated during the inverter error characteristic is determined.

**Remedy:** Only start identification at a device utilisation ([C00066](#)) of 0 % and/or reduce rated motor current ([C00088](#)) and reset it to the original value after the identification.



#### How to determine the inverter error characteristic:

1. If the controller is enabled, inhibit the controller, e. g. with the device command [C00002](#) = "41: Inhibit controller".
2. Execute device command [C00002](#) = "71: Calculate inv. error characteristic".
3. The detection of the inverter error characteristic starts with the [C00002](#) = "42: Enable controller" device command (or, alternatively, with the controller enable via terminal RFR).

#### Notes:

- By means of controller inhibit, the started procedure can be cancelled anytime, if required. Characteristic values that have already been determined in this case are rejected. Details on the procedure can be seen from the "Procedure" section below.
- After successful termination, the detected characteristic is set in the controller. The inverter error characteristic must only be detected again if the controller, motor, or motor cable has changed e.g. due to an exchange.

The following device commands are used to terminate the successful procedure:

4. Device command [C00002](#) = "11: Save start parameters" for a permanent acceptance of the characteristic.
5. Device command [C00002](#) = "41: Inhibit controller"
6. Device command [C00002](#) = "42: Enable controller"



#### Tip!

For controller enable all sources for controller inhibit must be reset. In [C00158](#) the sources for controller inhibit are displayed in a bit-coded manner.

The status of the device command activated under [C00002](#) is indicated under [C00003](#).

### Procedure

The detection of the inverter characteristic is started if

- no other identification is active,
- no error has occurred, and
- no test mode is activated.

If one of the above conditions is not met, the procedure is cancelled and the corresponding device command status is indicated under [C00003](#).

If all conditions are met, the motor is energised with a maximum direct current corresponding to the lower of the following two values:

$\sqrt{2} \cdot \text{Rated device current}$
or
$\sqrt{2} \cdot 1.8 \cdot \text{Rated motor current}$
Rated motor current, see <a href="#">C00088</a>

- Ideally, the first value should be reached, the second value is to ensure that the load on the machine is not too high during this test.

During the procedure, the motor current rises up to the specified maximum value and falls back to "0" to repeat the cycle with a negative current sign.

- The maximum value is reached four times.
- The switching frequency is set to rated switching frequency and after the procedure, it is reset to the original value.
  - If the switching frequency should be changed later during operation, the characteristic will be adapted to the current switching frequency.

### In the event of an error

If an error occurs during the procedure or the pulse inhibit gets active (e.g. due to short-time undervoltage), the procedure is terminated with controller inhibit and the detected characteristic is not considered.



#### Tip!

From software version V4.0: If it is not possible to determine the so-called "Inverter error characteristic", or if the results of the determination are incorrect, the device command [C00002](#) = "70: Load Lenze inverter characteristic" can be used to load a characteristic typical for the device. ▶ [Load Lenze INV characteristic \(□ 72\)](#)

### 5.3.5 Determining the motor parameters



#### Note!

Only required for servo control if the motor parameters are to be defined by a motor from a third-party manufacturer!

Always required for sensorless vector control!

- An optimum drive performance can only be achieved with the sensorless vector control if the motor parameters correspond to the real motor as exactly as possible.

To control an electrical machine, the motor parameters must be known.

- The motor parameters for Lenze motors are known and are already set accordingly by selecting them from the »Engineer« motor catalogue or reading out the ENP.
- The device command "Determine motor parameters" is used to automatically determine the motor parameters for a third-party motor that are listed in the following table – if they are not known:

Parameters	Info	ASM	SM
<a href="#">C00079</a>	Motor magnetising inductance	<input checked="" type="checkbox"/>	
<a href="#">C00082</a>	Motor rotor resistance	<input checked="" type="checkbox"/>	
<a href="#">C00084</a>	Motor stator resistance	<input checked="" type="checkbox"/>	<input checked="" type="checkbox"/>
<a href="#">C00085</a>	Motor stator leakage inductance	<input checked="" type="checkbox"/>	<input checked="" type="checkbox"/>
<a href="#">C00091</a>	Motor cosine phi	<input checked="" type="checkbox"/>	
<a href="#">C00092</a>	Motor magnetising current	<input checked="" type="checkbox"/>	



#### Danger!

This procedure may only be carried out during commissioning, not during operation!

- During the procedure the motor is energised so that:
  - it cannot be excluded that the connected mechanical components may move!
  - the windings heat up.
 If you repeat the procedure, ensure that the motor is not thermally overloaded (particularly if no temperature feedback is used).

For software versions lower than V4.0 the following applies:

- If the automatic brake operation is used, ensure that no basic function is requested or that the application is stopped before this procedure is called. Otherwise the applied holding brake could be released!
- For positioning applications you have to observe that the absolute position and the home position will get lost when this procedure is called. The loss of the home position is not signalled to the application. The following sequence has to be observed for positioning applications: 1.) Execute identification → 2.) Save parameter set → 3.) Restart controller → 4.) Execute homing procedure.

#### Prerequisites

- For the automatic determination of the motor parameters it is required that first the switching performance of the inverter has been optimised successfully, to ensure that the current has a sinusoidal form. ▶ [Optimising the switching performance of the inverter](#) (□ 138)

- The motor parameters listed in the following table are excluded from the automatic determination and must therefore be adapted to the motor used (see motor nameplate before the determination).

Parameters	Info
<a href="#">C00081</a>	Rated motor power
<a href="#">C00084</a>	Motor stator resistance (Default setting is used as starting value for the automatic determination.)
<a href="#">C00087</a>	Rated motor speed
<a href="#">C00088</a>	Rated motor current (The current amount for the procedure is derived from this specification)
<a href="#">C00089</a>	Rated motor frequency
<a href="#">C00090</a>	Rated motor voltage



### Note!

For devices of the types 9 + 10 (from 132 kW) the automatic determination of the motor parameters may fail and a corresponding status display is output.

**Remedy:** Parameterise the motor parameters manually by means of the manufacturer's data sheet.



### How to determine the motor parameters:

1. If the controller is enabled, inhibit the controller, e. g. with the device command [C00002](#) = "41: Inhibit controller".
2. Execute device command [C00002](#) = "72: Determine motor parameters".

The procedure starts with controller enable, if

- no other identification is active,
- no error has occurred, and
- no test mode is activated.

If one of the above conditions is not met, the procedure is cancelled and the corresponding device command status is indicated under [C00003](#).

#### Note:

By means of controller inhibit, the started procedure can be cancelled anytime, if required, without altering the codes for the motor parameters.

For detailed information about the procedure, please see the following section "Sequence".

**Tip!**

For controller enable all sources for controller inhibit must be reset. In [C00158](#) the sources for controller inhibit are displayed in a bit-coded manner.

The status of the device command activated under [C00002](#) is indicated under [C00003](#).

**Procedure**

If all conditions are met, the impedance of the controlled system is determined for approx. 30 different frequencies. These values are used to determine the electrical machine parameters by means of a mathematical procedure.

- Since the procedure starts with very low frequencies and always considers several complete periods, the whole process takes approx. 3 minutes.
- During the procedure, the motor is energised with a current, the r.m.s. value of which corresponds to the lower of the following two values:

Rated device current
or
$\frac{1}{2} \cdot \text{Rated motor current}$

After the parameters have been extracted from the impedance, they are checked for consistency with the required rated values. If an inconsistent parameter set is detected, is this an indication of faulty rated values on the nameplate.

**Note!**

During the procedure, the motor should not rotate.

With synchronous machines, this cannot always be ensured. Although the current flow is produced in the torque-neutral axis, asymmetries in the machine lead to a rotation of the rotor.

- In such a case, the measurement would be useless and would have to be repeated.
- As a remedy, we recommend to use a holding brake.

With asynchronous machines, slight rotations might possibly occur. Their influence on the measurements is, however, not worth mentioning.

- In case of uncertainties, the measurement should be repeated several times to check if the results for the stator resistance, the leakage inductance of the stator and the rotor resistance differ widely. This should not be the case.
- The mutual inductance and the  $\cos(\varphi)$  values are not that important for the diagnostics, because they are strongly non-linear.

**After successful completion...**

...controller inhibit is set automatically and the motor data determined are set in the corresponding codes.

- For a permanent acceptance of the settings, the parameter set must be saved ([C00002](#) = "11: Save start parameters").
- With the device command [C00002](#) = "42: Enable controller" the controller inhibit set automatically during the procedure can be deactivated again.

### In the event of an error

If an error occurs during the procedure or the pulse inhibit gets active (e.g. due to short-time undervoltage), the procedure is terminated with controller inhibit without changing the codes for the motor parameters.

### Display and manual adjustment of motor data

In »Engineer« you can have an equivalent circuit diagram with the motor parameters displayed by clicking on the **Further motor data...** button on the **Application parameters** in the dialog level *Overview*→*Motor*→*Motor*:

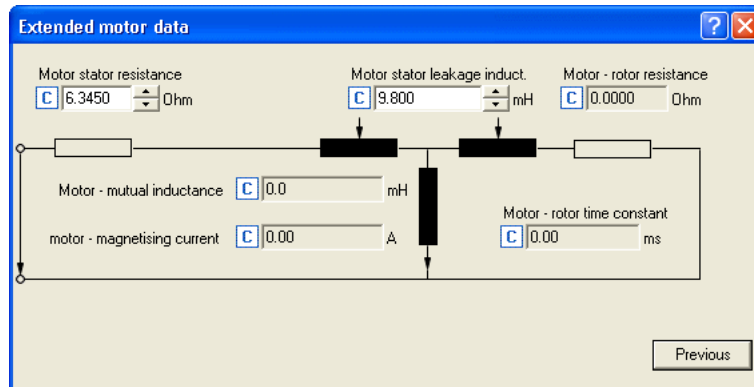

- The representation of the equivalent circuit diagram depends on the motor control selected ([C00006](#)).
- The motor stator resistance ([C00084](#)) and motor stator leakage inductance ([C00085](#)) can be altered directly via the input fields in the equivalent circuit diagram.
- The motor magnetising current ([C00092](#)) is displayed as comparison value to the motor current ([C00054](#)).
  - The motor magnetising current must especially be observed in case of a no-load operation, both at standstill and with rated speed.
  - The motor magnetising current is directly calculated from the rated motor current ([C00088](#)) and the motor power factor ([C00091](#)).
- The mutual motor inductance can be indirectly adapted via the parameter Lh adjustment ([C02861](#)) in the range of 50 ... 200 %. The mutual motor inductance evaluated in percent is shown in [C00079](#).
- The motor rotor resistance can be indirectly adapted via the parameter Rr adjustment ([C02860](#)) in the range of 50 ... 200 %. The motor rotor resistance evaluated in percent is shown in [C00082](#).



# 5 Motor interface

## 5.4 Servo control (SC)

---

### 5.4 Servo control (SC)

In the Lenze setting the servo control for synchronous motors is selected in [C00006](#).

After the motor and controller are optimally adjusted to each other, no more basic settings are required for servo control.



#### Tip!

How to optimise the control behaviour and adjust it to the concrete application is described in the chapter "[Optimising the control mode](#)". ([📖 146](#))

From software version V2.0 the parameterisable additional function "[Field weakening for synchronous machines](#)" is provided for the servo control. ([📖 209](#))

### 5.4.1 Optimising the control mode

The "optimisation steps" given in the following table serve to further optimise the control behaviour of the servo control and adjust it to the concrete application.

- Detailed information on the individual steps can be found in the following subchapters.

Optimisation steps	
1	<a href="#">Optimise current controller.</a> (📖 147) <ul style="list-style-type: none"> <li>• The current controller should always be optimised if a motor of a third-party manufacturer with unknown motor data is used!</li> </ul>
	Parameterise selected technology application in »Engineer« and load it into the controller. <ul style="list-style-type: none"> <li>• See description of the corresponding technology application.</li> <li>• During operation (with setpoint selection) further steps can be carried out to optimise the motor control:</li> </ul>
2.	<a href="#">Optimising the speed controller.</a> (📖 150) <ul style="list-style-type: none"> <li>• Via running a typical speed profile and recording the ramp response of the speed controller with the oscilloscope.</li> </ul>
3	If the speed controller optimisation did not achieve the intended result: <a href="#">Set current setpoint filter (band-stop filter).</a> (📖 153) <ul style="list-style-type: none"> <li>• In order to suppress or damp (mechanical) resonant frequencies, two current setpoint filters are integrated in the speed control loop of the controller which are switched off in the default setting but can be parameterised accordingly, if required.</li> </ul> Then readjust the speed controller: <a href="#">Optimising the speed controller.</a> (📖 150)
4	<a href="#">Optimising phase controller.</a> (📖 156) <ul style="list-style-type: none"> <li>• Via running a typical speed profile and recording the ramp response of the phase controller with the oscilloscope.</li> </ul>
5	<a href="#">Optimising response to setpoint changes.</a> (📖 157) <ul style="list-style-type: none"> <li>• Via running a typical speed profile and recording the inputs and outputs of the speed controller with the oscilloscope.</li> </ul>
6	<a href="#">Setting the field weakening for asynchronous machines.</a> (📖 159) <ul style="list-style-type: none"> <li>• By means of traversing a speed profile <math>0 \leftrightarrow n_{\max}</math> and recording the speed, flow, and D-current setpoints/ actual values with the oscilloscope.</li> </ul>
7	Save »Engineer« project.



#### Tip!

To run a typical speed profile for optimising the motor control, you can also use the basic function "manual jog" with suitably adapted manual jog parameters if this basic function is supported by the technology application selected. ▶ [Manual jog](#) (📖 400)

### 5.4.1.1 Optimise current controller



#### Note!

The current controller should always be optimised if a motor of a third-party manufacturer with unknown motor data is used!

An optimisation of the current controller is useful, as the two controller parameters gain ([C00075](#)) and reset time ([C00076](#)) depend on the maximum current required and the switching frequency set.

For this purpose, the controller parameters only need to be adapted once at a fixed switching frequency.

We recommend to select a switching frequency

- as low as possible if the controller is to be operated frequently at the maximum current limit.
- of 8 kHz (up to and including model 7) or 4 kHz (from model 8 onwards) if the maximum current limit will not be reached or will only be reached rarely.

The controller parameters are then automatically adapted to the other switching frequencies.

In a test mode you can select current setpoint step-changes and optimise the setting of both control parameters by evaluating the step responses.

- The starting values for gain and reset time can be calculated with the following formula:

$$\text{Gain} = \frac{\text{Stator leakage inductance}}{340 \mu\text{s}}$$
$$\text{Reset time} = \frac{\text{Stator leakage inductance}}{\text{Stator resistance}}$$

**How to optimise the current controller in the test mode:**

1. If the controller is enabled, inhibit the controller, e. g. with the device command [C00002](#) = "41: Inhibit controller".
2. Set a fixed switching frequency using [C00018](#). Observe the above mentioned recommendations.
3. Activate one of the two following optimisation modes for the current controller:
  - [C00398](#) = "3: Current controller optimisation mode":  
After controller enable, the motor is supplied with current as long as the controller is enabled.
  - From software version V7.0:  
[C00398](#) = "4: Current controller optimisation mode pulse":  
The motor is supplied with voltage for 50 ms after controller enable. Due to this time limit, the load of the machine is reduced. Afterwards, the controller is inhibited automatically.
4. Select the effective value of the current setpoint step change under [C00022](#).
  - The peak value of the measurable motor current will be 1.41 times higher.
5. Enable the controller for a short time and measure the step response of the motor current in the motor phases using the oscilloscope and clamp-on ammeters or record the field-oriented direct-axis current using the [Oscilloscope](#) function in »Engineer«. ([📖 585](#))
  - Variable of the motor control to be recorded:  
*Current.dnActualDirectCurrent* (field-oriented direct-axis current)

## 6. Evaluate the step response:

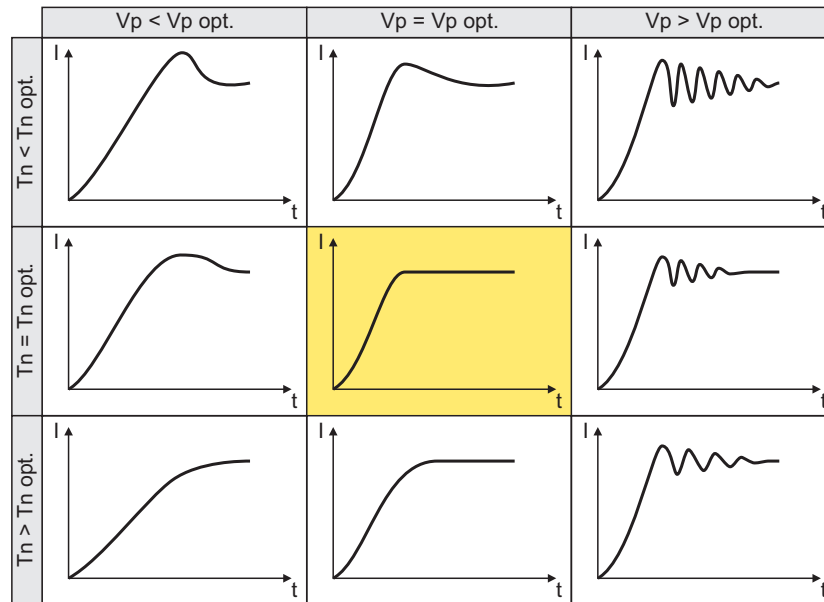

7. Change the gain  $V_p$  under [C00075](#) and the reset time  $T_n$  under [C00076](#).
8. Repeat steps 4 ... 6 until the optimum step response of the motor current is reached.
  - In the optimised state the current rise time typically is 0.5 ... 1 ms.
  - If the adjustment results are not satisfactory, the decoupling network can be additionally activated via the setting [C00074](#) = "1". After this, repeat the steps 2 ... 6.
  - In case of MCS, satisfying results may only be achieved with a current-dependent correction of the current controller parameters based on the saturation behaviour of the motor stator leakage inductance. For this purpose, it is required to use a motor with an electronic nameplate (ENP) or to set the saturation characteristic manually. ▶ [Correction of the stator leakage inductance...](#) (📖 204)
9. After the optimisation has been completed, deactivate the test mode again ([C00398](#) = "0: Test mode deactivated").
10. Save parameter set ([C00002](#) = "11: Save start parameters").

### 5.4.1.2 Optimising the speed controller

The speed controller is designed as PID controller.

#### Gain setting

The proportional gain  $V_p$  is selected under [C00070](#):

1. Select the speed setpoint.
2. Increase C00070 until the drive becomes unstable (observe motor noises).
3. Reduce C00070 until the drive becomes stable again.
4. Reduce C00070 to approx. half the value.

#### Reset time setting

The reset time  $T_n$  is selected under [C00071](#):

1. Reduce C00071 until the drive becomes unstable (observe motor noises).
2. Increase C00071 until the drive is stable again.
3. Increase C00071 to approx. double the value.

#### Rate time setting

The rate time  $T_d$  is selected under [C00072](#):

- Increase C00072 during operation until an optimum control behaviour is reached.

### Using the ramp response for setting the speed controller

When operation of the mechanics at the stability limit is not possible, the ramp response can be used to set the speed controller. The proceeding is similar to optimising the current controller.



#### Stop!

If the controller parameters are preset unfavourably, the control can tend to heavy overshoots up to instability!

- Following and speed errors can adopt very high values.
- If the mechanics are sensitive, the corresponding monitoring functions are to be activated.



#### How to optimise the speed controller setting by means of the ramp response:

1. Run a typical speed profile and record the ramp response of the speed with the [Oscilloscope](#). (☒ 585)
  - Motor control variables to be recorded:  
*Speed.dnSpeedSetpoint* (speed setpoint)  
*Speed.dnActualMotorSpeed* (actual speed value)
2. Evaluate the ramp response:

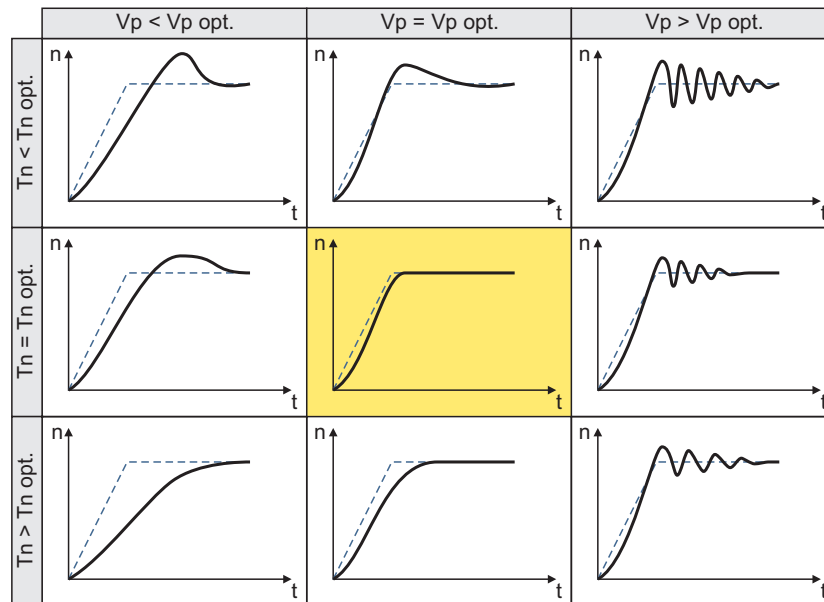

- Solid line = ramp response (actual speed value)
- Dash line = speed setpoint

3. Change the gain  $V_p$  under [C00070](#) and the reset time  $T_n$  under [C00071](#).
4. Repeat steps 1 ... 3 until the optimum ramp response is reached.
5. Save parameter set ([C00002](#) = "11").

### Setting of actual speed filter

In order to maximise the dynamics of the speed control loop, the actual speed filter should be operated with a time constant as low as possible ([C00497](#)). The lower the time constant the higher the gain of the speed controller. Since actual value filters have the task to dampen measuring errors or interference components, it must be found a compromise between filter task and the resulting delay.

If a Lenze motor is selected from the motor catalogue, a time constant is automatically preset in [C00497](#) which serves to operate the motor even with a faulty detection (e.g. in case of a bad shield connection).

When using EMC-compliant systems or high-quality encoders, you can reduce the preset time constant considerably. For this purpose, the running noise of the motor can be used for setting [C00497](#) at constant speed.

If this is not possible, e.g. due to a too loud environment or because the motor is too far away, the noise of the actual speed value or the setpoint torque value can be used for evaluation by means of the [Oscilloscope](#). Please observe that the speed controller gain  $V_p$  ([C00070](#)) is used for the torque setpoint.

### Dynamics of the actual value detection

Another element which influences the maximally achievable control dynamics, is the dynamics of the actual value detection itself. In case of optical encoders, the time delay by the actual value detection does not need to be considered. This does not apply to resolvers.

The resolver evaluation of the controller is adapted to the resolver types mounted in Lenze motors and offers a good compromise between the dynamic performance and interference suppression. If the resolver is used as a speed feedback system, the dynamic performance of the resolver evaluation determines, among other things, the maximum speed controller gain by means of which stable operation is possible.

From software version V5.0 onwards, it is possible to increase the dynamics of the resolver evaluation in [C00417](#) in an EMC-compliant system (with low interference) without a quality loss in the speed signal.

▶ [Adaptation of the resolver evaluation dynamics](#) (📖 253)



# 5 Motor interface

## 5.4 Servo control (SC)

### 5.4.1.3 Set current setpoint filter (band-stop filter)

Due to the high dynamic performance or the high limit frequency of the closed current control loop, mechanical natural frequencies can be excited, which can result in resonance and thus cause the speed control loop to become unstable.

In order to suppress or damp these resonant frequencies, two current setpoint filters are integrated in the speed control loop of the controller, which need to be parameterised. In the Lenze setting, these filters are switched off:

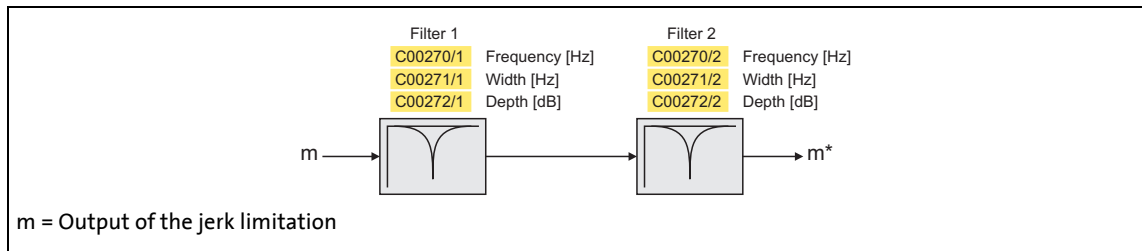

[5-2] Optional current setpoint filters (filter cascade) in the speed control loop

#### Overview of parameters for current setpoint filter

Parameters	Info	Lenze setting	
		Value	Unit
<a href="#">C00270/1</a>	Freq. - current setpoint filter 1	200.0	Hz
<a href="#">C00270/2</a>	Freq. - current setpoint filter 2	400.0	Hz
<a href="#">C00271/1</a>	Width current setp. filter 1	20.0	Hz
<a href="#">C00271/2</a>	Width current setp. filter 2	40.0	Hz
<a href="#">C00272/1</a>	Depth current setp. filter 1	0	dB
<a href="#">C00272/2</a>	Depth current setp. filter 2	0	dB

### Use of the current setpoint filters depending on the resonant frequency



#### Stop!

If the filter parameters are set incorrectly, the impaired closed-loop control can respond with too large overshoots and cause the controller to become unstable, e.g. if the filter width is set to a value more than twice as large as the filter frequency.

After setting the filter parameters, the drive behaviour during stop and quick stop (QSP, Fail-QSP) must be checked. If impairments exist,

- the drive that is still running must either be coasted down by activating the controller inhibit or immediately be brought to a standstill via a brake.
- the speed controller must be optimised again afterwards.
- the test procedure must be repeated.

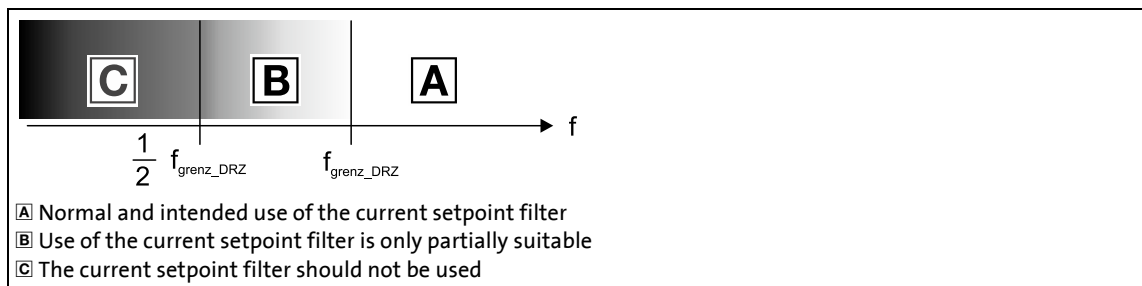

[5-3] Use of the current setpoint filter depending on the resonant frequency

- Resonant frequencies  $\geq f_{\text{limit\_SPEED}} = 70 \text{ Hz} \dots 110 \text{ Hz}$

This filter is suitable for use with resonant frequencies in the range around or above the limit frequency of the speed controller.

- Resonant frequencies  $< f_{\text{limit\_SPEED}}$

Please follow the Lenze recommendation and select suitable speed profiles, S-ramp or S-rounding, for avoiding resonances.

#### Setting of the current setpoint filter

Since the frequency response of the speed controlled system is only rarely known to such an extent that the current setpoint filters can be adjusted to the controlled system in the run-up, the following example describes an experimental procedure for setting the current setpoint filters:



### How to set the current setpoint filters:

1. Adjust the current control loop.
  2. Go to [C00071](#) and adapt the reset time of the speed controller to the filter time constant of the speed filter ([C00497](#)) and the equivalent time constant of the current control loop:  $C00071 = 16 * (C00497 + 200 \mu s)$
- Note:** The setting of [C00071](#) incorporates the equivalent time constant of the current control loop. The indicated 200  $\mu s$  are typical in a power range of up to 20 kW. Beyond it, higher time constants may occur.
3. Slowly increase the proportional gain in [C00070](#) until the speed control loop starts to become unstable (acoustic determination or measuring of the motor current).
  4. Measure the oscillation frequency using an oscilloscope (observe current or speed).
  5. Set the measured oscillation frequency in [C00270/1](#) as filter frequency.
  6. Set "50%" of the filter frequency in [C00271/1](#) as filter width.
    - Example: filter frequency = 200 Hz → filter width = 100 Hz.
  7. Set "40 dB" in [C00272/1](#) as filter depth.
    - If the filter depth is set to "0 dB" (default setting), the filter is not active.
  8. Further increase the proportional gain in [C00070](#) until the speed control loop starts to become unstable again.
    - If the oscillation frequency has changed now, readjust the filter frequency by trimming. The use of a second filter is ineffective here.
    - If the oscillation frequency remains the same, readjust the filter depth and/or the filter width by trimming (the first reduces the amplitude, the second lets the phase rotate faster).
    - Repeat step 8 until the desired behaviour or the limit of a sensible speed controller gain has been reached.
  9. Save parameter set ([C00002](#) = "11: Save start parameters").



### Note!

Readjust the speed controller after setting the current setpoint filter. ▶ [Optimising the speed controller](#). (150)

### 5.4.1.4 Optimising phase controller



**How to optimise the phase controller setting by means of the ramp response:**

1. Run a typical speed profile and record the ramp response of the phase controller with the [Oscilloscope](#). ([□ 585](#))
  - Motor control variables to be recorded:
    - Speed.dnSpeedSetpoint* (speed setpoint)
    - Speed.dnActualMotorSpeed* (actual speed value)
    - Speed.dnOutputPosCtrl* (phase controller output)
    - Position.dnEncounteringError* (following error)
2. Adjust the gain  $V_p$  of the phase controller under [C00254](#) and repeat oscilloscope recording until the intended following error behaviour is reached and the motor runs sufficiently smoothly during the constant travel phase.
3. Save parameter set ([C00002](#) = "11: Save start parameters").

### 5.4.1.5 Optimising response to setpoint changes

Setting the load moment of inertia under [C00273/2](#) does not always provide the optimum torque feedforward control. Depending on the application, an adjustment of the setting under [C00273/2](#) may be necessary to optimise the response to position/speed setpoint changes by means of the torque feedforward control.

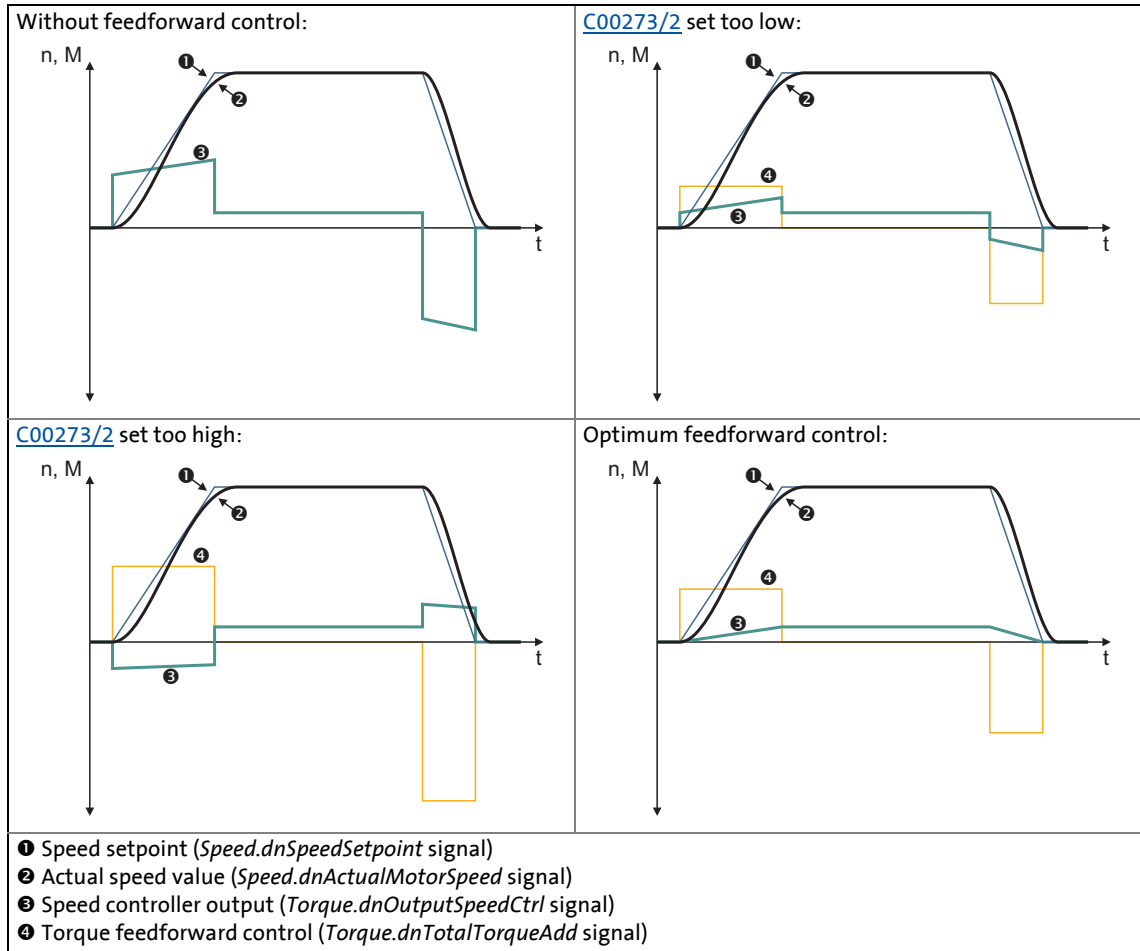

[5-4] Typical signal characteristics for different settings of the load moment of inertia

Apart from the load moment of inertia, effects can be compensated with [C00273/2](#), which in the closed speed control loop are identified by the speed controller. These for example include the friction torques.

Below you will find a description of a procedure for optimising the feedforward control behaviour starting from the system's moment of inertia.



#### How to optimise the torque feedforward control:

- Run a typical speed profile and record the inputs and outputs of the speed controller with the [Oscilloscope](#). ([□ 585](#))
  - Motor control variables to be recorded:
    - Speed.dnSpeedSetpoint* (speed setpoint)
    - Speed.dnActualMotorSpeed* (actual speed value)
    - Torque.dnOutputSpeedCtrl* (speed controller output)
    - Torque.dnTotalTorqueAdd* (torque feedforward control)
  - Application variable to be recorded (if available):
    - L\_LdMonitFollowError1.dnFollowErrorIn\_p* (following error)

It is essential for optimising the response to setpoint changes to monitor the speed controller output (*Torque.dnOutputSpeedCtrl*) and the torque feedforward control (*Torque.dnTotalTorqueAdd*). The effect of the feedforward control can also be observed in the following error.

2. Select the signal source required for the torque setpoint (feedforward control path) under [C00276](#).
3. Estimate the load moment of inertia and set it under [C00273/2](#) with regard to the motor end (i.e. considering the gearbox factors).
4. Repeat the oscilloscope recording (see step 1).

Now the oscillogram should show that part of the required torque is generated by the feedforward control (*Torque.dnTotalTorqueAdd*) and the speed controller output signal (*Torque.dnOutputSpeedCtrl*) should be correspondingly smaller. The resulting following error decreases.

5. Change the setting under [C00273/2](#) and repeat the oscilloscope recording until the intended response to setpoint changes is reached.
  - The optimisation could aim at the speed controller being completely relieved (see signal characteristics in Fig. [5-4](#)).
6. Save parameter set ([C00002](#) = "11: Save start parameters").

### 5.4.1.6 Setting the field weakening for asynchronous machines

For the following setting instructions it is assumed that the drive has been adjusted in the base speed range (inverter error characteristic, motor parameters, current controller, speed controller, current setpoint filter, angle controller, torque feedforward control) and is running satisfactorily to the rated motor speed.



#### How to set the field weakening for an asynchronous machine:

1. Set the desired maximum speed (with field weakening) in [C00011](#).
2. Carry out the following basic setting for the controller parameters for third-party motors:
  - Field controller gain ([C00077](#)) =  $1 / (2 * \text{C00082} * 500 \mu\text{s})$
  - Field controller reset time ([C00078](#)) = motor rotor time constant ([C00083](#))
  - Field weakening controller gain ([C00577](#)) = 0 [Vs/V]
  - Field weakening controller reset time ([C00578](#))  
 =  $4 \text{ ms} / (0.3 \dots 1.0 * 60) * \text{C00059} * 2\pi * \text{C00011} [\text{rpm}] * \text{s}$   
 (with factor 0.3 ... 1.0 for motor with rated power of 400 kW ... 0.4 kW)

#### Optimising the static behaviour in the field weakening range:

3. By means of speed ramp (acceleration time several seconds), slowly accelerate to the field weakening range up to maximum speed ([C00011](#)), and decelerate to speed 0 again and record the signal characteristic using the [Oscilloscope](#) (see example oscillogram [\[5-5\]](#)).
  - From the entry into the field weakening range, the flow setpoint (output of the field weakening controller) should decrease with  $1/n$ . Influences of the DC-bus voltage may be seen in the flow setpoint. The signal characteristic should preferably be "smooth".
  - From the entry into the field weakening range, the D-current setpoint (output of the field controller) should always decrease with  $1/n$ . In the signal characteristic no heavy vibrations may occur.

**Optimising the dynamic behaviour in the field weakening range:**

4. Adapt the dynamic performance to the behaviour required for the machine application.
5. Repeat the recording of the speed characteristic and record the small signal range in the field weakening range ( $n_1 \leftrightarrow n_2$ ).
  - If the flow setpoint is adapted to the speed too slowly, increase the dynamic performance of the field weakening controller: reduce the reset time ([C00578](#)) in small steps, the gain ([C00577](#)) should remain set to 0 [Vs/V] for most machines.
  - If the flow setpoint in the field weakening range falls "too early" with  $1/n^2$  (stability limit of the machine reached), the leakage inductance of the motor ([C00085](#)) may be reduced a bit.
  - If the actual flow value follows the flow setpoint too slowly, increase the dynamic performance of the field controller: increase gain ([C00077](#)), reduce reset time ([C00078](#)).
  - If the actual D-current value does not correspond enough to the D-current setpoint, the dynamic performance of the current controller has to be adapted. ▶ [Optimise current controller](#) (📖 147)
  - If the motor speed does not feature the desired characteristic, the speed controller has to be readjusted with maximum speed in the field weakening range. ▶ [Optimising the speed controller](#) (📖 150)

**Checking the motor parameters:**

6. Carry out dynamic measurement in the range  $-n_{Max} \leftrightarrow +n_{Max}$  and record the motor speed using the [Oscilloscope](#).
  - The objective is a preferably linear speed characteristic.
  - In particular check the ranges around the rated motor speed and speed 0 and, if required, improve them by adjusting  $R_R$  ([C02860](#)) or  $L_H$  ([C02861](#))!



### Example oscillogram

Ch	Variable of the motor control	Unit	1/Div	Offset	Position
1	Speed.dnActualMotorSpeed (current speed)	rpm	1k	0	-4
2	Voltage.dnActualMotorVoltage (current motor voltage)	V	100	0	-5
3	Torque.dnActualMotorTorque (current motor torque)	Nm	500m	0	0
4	Speed.dnSpeedSetpoint (speed setpoint)	rpm	1k	0	-4
5	Common.dnFluxSet (flux setpoint)	%	20	0	-5
6	Common.dnActualFlux (actual flux value)	%	20	0	-5
7	Current.dnDirectCurrentSet (D-current setpoint)	A	1	0	0
8	Current.dnActualDirectCurrent (actual D-current value)	A	1	0	0

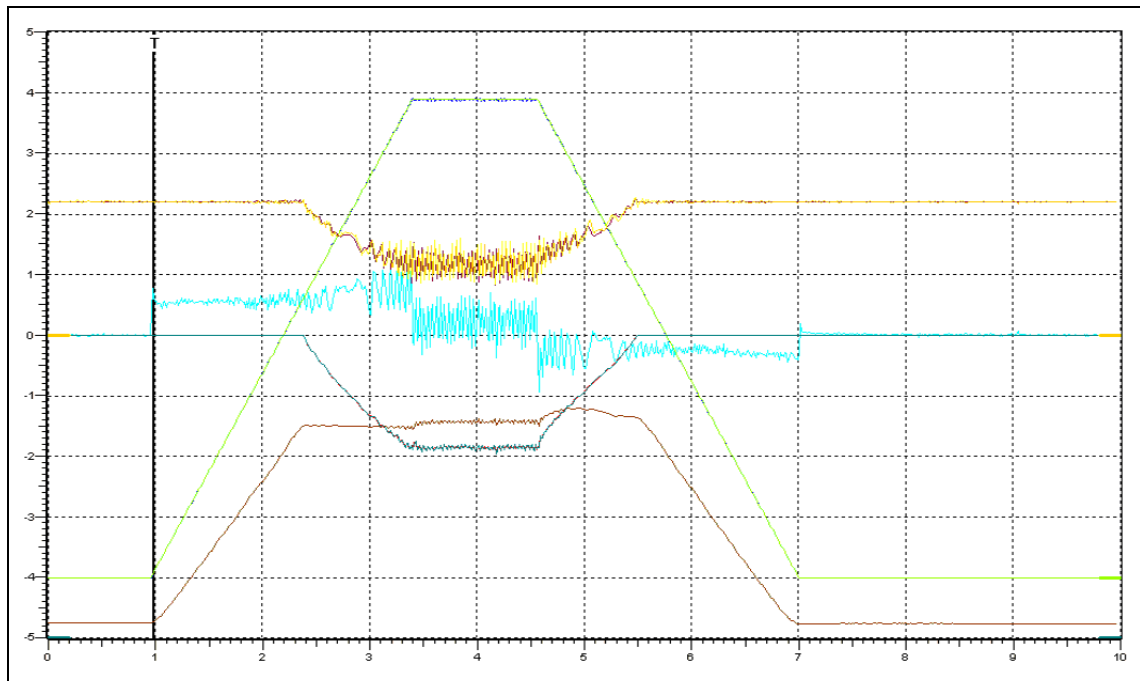

[5-5] Example oscillogram

### 5.4.2 Signal flow (servo control for synchronous motor)

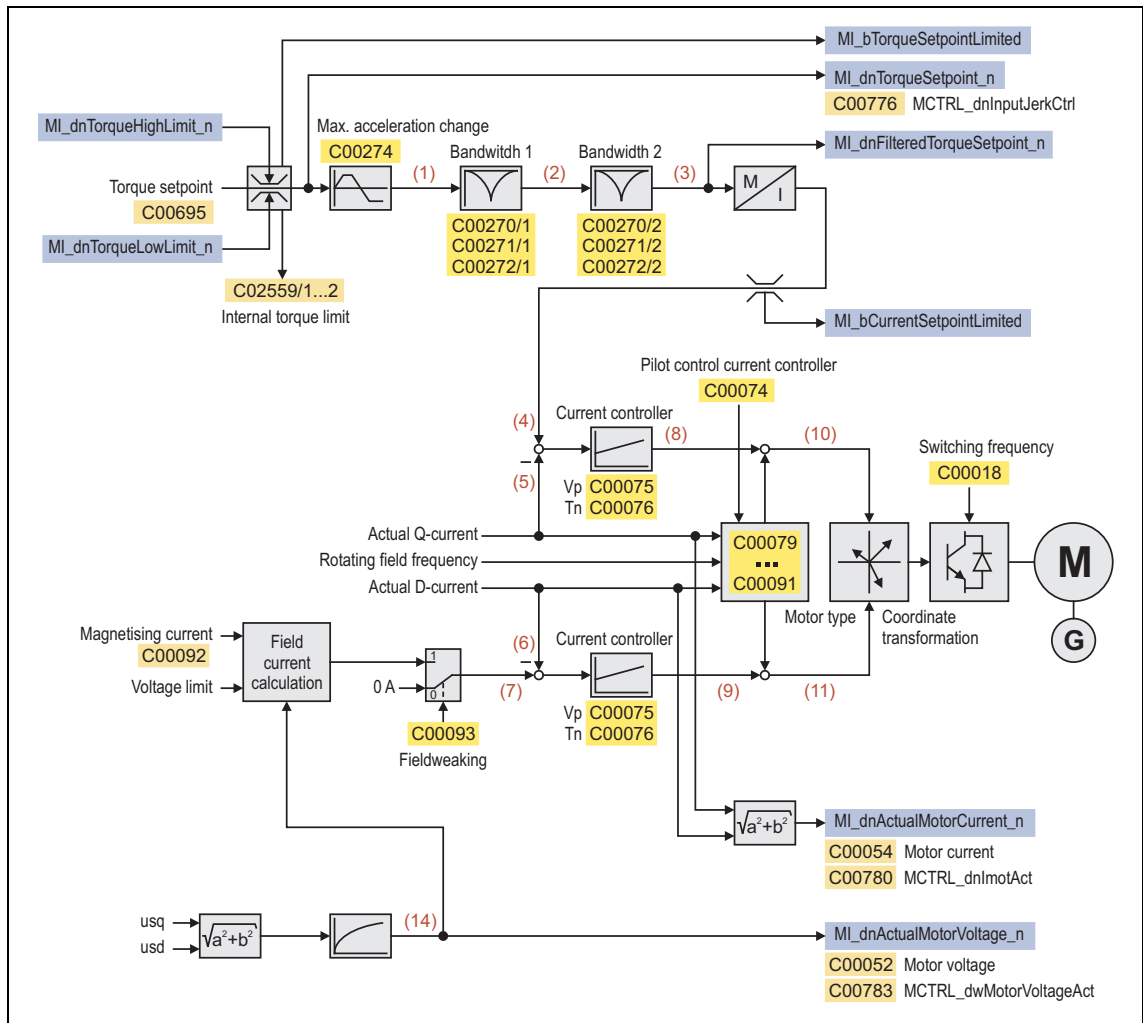

[5-6] Signal flow - servo control for synchronous motor

See also:

- ▶ [Signal flow - encoder evaluation](#) (📖 243)
- ▶ [Signal flow - speed follower](#) (📖 498)
- ▶ [Signal flow - torque follower](#) (📖 503)
- ▶ [Signal flow - position follower](#) (📖 492)

**Internal variables of the motor control (oscilloscope signals)**

- The red numbers in brackets listed in the signal flow stand for internal variables of the motor control, which you can record by means of the [Oscilloscope](#) for purposes of diagnostics and documentation. ([📄 585](#))

No.	Variable of the motor control	Meaning
(1)	Torque.dnInputNotchFilter1	Torque setpoint at the band-stop filter input 1
(2)	Torque.dnInputNotchFilter2	Torque setpoint at the band-stop filter 2 input
(3)	Torque.dnFilteredTorqueSetpoint	Filtered torque setpoint
(4)	Current.dnQuadratureCurrentSet	Q current setpoint
(5)	Current.dnActualQuadratureCurrent	Actual Q current
(6)	Current.dnActualDirectCurrent	Actual D current
(7)	Current.dnDirectCurrentSet	D current setpoint
(8)	Voltage.dnOutputQuadratureCurrentCtrl	Q-output voltage of the current controller
(9)	Voltage.dnOutputDirectCurrentCtrl	D-output voltage of the current controller
(10)	Voltage.dnQuadratureVoltage	Q voltage
(11)	Voltage.dnDirectVoltage	D voltage
(12)	-	
(13)	-	
(14)	Voltage.dnActualMotorVoltage	Current motor voltage

### 5.4.3 Signal flow (servo control for asynchronous motor)

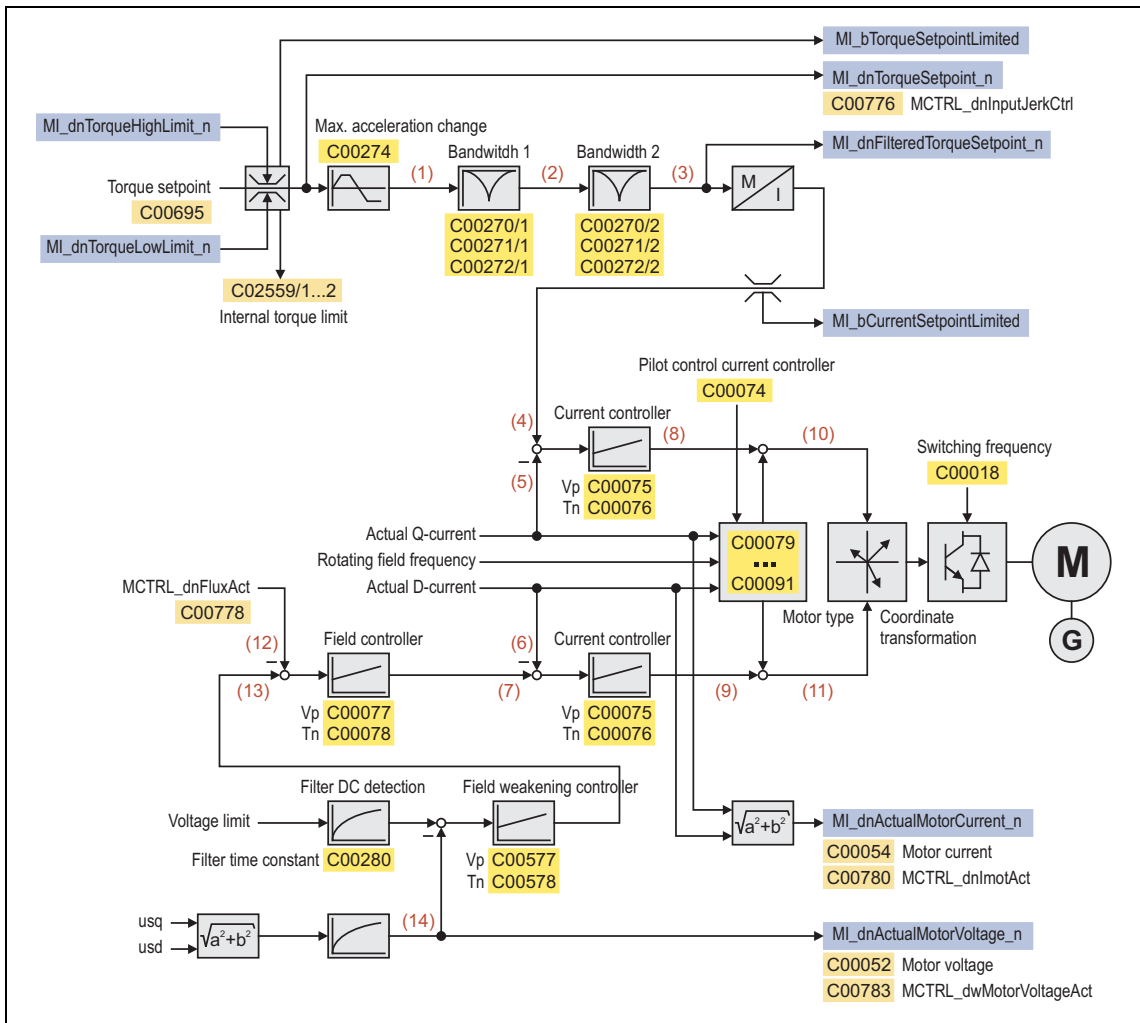

[5-7] Signal flow - servo control for asynchronous motor

See also:

- ▶ [Signal flow - encoder evaluation](#) (📖 243)
- ▶ [Signal flow - speed follower](#) (📖 498)
- ▶ [Signal flow - torque follower](#) (📖 503)
- ▶ [Signal flow - position follower](#) (📖 492)

**Internal variables of the motor control (oscilloscope signals)**

- The red numbers in brackets listed in the signal flow stand for internal variables of the motor control, which you can record by means of the [Oscilloscope](#) for purposes of diagnostics and documentation. ([📄 585](#))

No.	Variable of the motor control	Meaning
(1)	Torque.dnInputNotchFilter1	Torque setpoint at the band-stop filter input 1
(2)	Torque.dnInputNotchFilter2	Torque setpoint at the band-stop filter 2 input
(3)	Torque.dnFilteredTorqueSetpoint	Filtered torque setpoint
(4)	Current.dnQuadratureCurrentSet	Q current setpoint
(5)	Current.dnActualQuadratureCurrent	Actual Q current
(6)	Current.dnActualDirectCurrent	Actual D current
(7)	Current.dnDirectCurrentSet	D current setpoint
(8)	Voltage.dnOutputQuadratureCurrentCtrl	Q-output voltage of the current controller
(9)	Voltage.dnOutputDirectCurrentCtrl	D-output voltage of the current controller
(10)	Voltage.dnQuadratureVoltage	Q voltage
(11)	Voltage.dnDirectVoltage	D voltage
(12)	Common.dnActualFlux	Actual flux value
(13)	Common.dnFluxSet	Flux setpoint
(14)	Voltage.dnActualMotorVoltage	Current motor voltage

## 5 Motor interface

### 5.5 Sensorless vector control (SLVC)

---

#### 5.5 Sensorless vector control (SLVC)

This function extension is available from software version V3.0!

If this motor control mode is set in [C00006](#), a considerably higher torque and a lower current consumption in idle state can be achieved compared to the V/f control mode.



#### Note!

Observe the following application limits of the sensorless vector control:

- Only approved for power up to 55 kW and horizontal applications (no hoists or lifting equipment)
- For single drives only
- For asynchronous motors only
- Not suitable for operation in generator mode/braking operation (e. g. unwinders)



#### Tip!

For vertical drives/hoists, use the servo control (with feedback), or the V/f control with activated voltage vector control (VVC), which supports vertical drives/hoists up to 55 kW.

### 5.5.1 Basic settings

After the motor and controller have been optimally adjusted to each other, the "initial commissioning steps" described in the following table are sufficient for a quick initial commissioning.

- Detailed information on the individual steps can be found in the following subchapters.

Initial commissioning steps	
1	<a href="#">Parameterising speed and torque controller.</a> (📖 168)
2.	<p>Additional "flying restart" function:</p> <ul style="list-style-type: none"> <li>• In the Lenze setting, this parameterisable additional function is activated.</li> <li>• If the flying restart function is not required, deactivate this function. ▶ <a href="#">Flying restart function</a> (📖 212)</li> </ul> <p> <b>Only deactivate the flying restart if it is ensured that the drive is always at standstill in the case of controller enable!</b></p>
3	<p>Additional "DC-injection braking" function:</p> <ul style="list-style-type: none"> <li>• In the Lenze setting, this parameterisable additional function is deactivated.</li> <li>• If DC-injection braking is required, activate this function. ▶ <a href="#">DC-injection braking</a> (📖 215)</li> </ul>



#### Tip!

A precise adjustment of the motor parameters for an improved concentricity factor and stability is described in the chapter "[Optimising motor parameters](#)". (📖 169)

How to optimise the control behaviour and adjust it to the concrete application is described in the chapter "[Optimising the control mode](#)". (📖 175)

Parameterisable additional functions are described correspondingly in the chapter "[Parameterisable additional functions](#)". (📖 203)

### 5.5.1.1 Parameterising speed and torque controller

#### Short overview: Parameters for controller settings

Parameters	Info	Lenze setting	
		Value	Unit
<a href="#">C00070</a>	Speed controller gain	0.500	Nm/rpm
<a href="#">C00071</a>	Speed controller reset time	24.0	ms
<a href="#">C00987</a>	SLVC: Torque controller gain	0.5000	Hz/A
<a href="#">C00988</a>	SLVC: Torque controller reset time	10.00	ms

#### Typical controller settings

The following table contains typical guide values concerning the setting of the speed and torque control for different device types/motor powers:

Device type	Motor power (4-pole standard ASM)	Speed controller		Torque controller	
		Gain <a href="#">C00070</a> [Nm/rpm]	Reset time <a href="#">C00071</a> [ms]	Gain <a href="#">C00987</a> [Hz/A]	Reset time <a href="#">C00988</a> [ms]
E0024	0.37 kW	0.0122	50.00	5.0833	10.00
E0034	0.75 kW	0.0138	50.00	3.0500	10.00
E0044	1.50 kW	0.0264	50.00	1.9818	10.00
E0074	3.00 kW	0.0411	50.00	1.1077	10.00
E0134	5.50 kW	0.0674	50.00	0.5965	10.00
E0174	7.50 kW	0.1183	50.00	0.3303	10.00
E0244	11.00 kW	0.1183	50.00	0.3303	10.00
E0324	15.00 kW	0.2244	50.00	0.2368	10.00
E0474	22.00 kW	0.3442	50.00	0.1547	10.00
E0594	30.00 kW	1.1503	50.00	0.1232	10.00
E0864	45.00 kW	1.7400	50.00	0.0817	10.00
E1044	55.00 kW	2.1712	50.00	0.0661	10.00

[5-8] Typical controller settings

The gain for the field current controller ([C00985](#)) and the gain for the cross current controller ([C00986](#)) are initially set to "0.00".



### 5.5.2 Optimising motor parameters

Although the motor parameters have been determined before as described in the chapter "[Adjusting motor and controller to each other](#)", an additional optimisation may be required in the following cases using the adjustment processes described in this chapter:

- When the concentricity factor in the lowest speed range is to be improved.
- When the stability in the lower speed range is to be improved.
- When the rated torque is not reached in the rated point, i. e. at rated speed and rated current.
- When a too high magnetising current is injected in idle state.

#### General information on the motor parameter adjustment

The motor stator resistance can generally always be adjusted with a passive load since the motor is stopped when this parameter is set.

An optimisation of the mutual motor inductance, however, is only sensible when the motor rotates in the medium speed range. In the majority of cases, the no-load operation is sufficient for this adjustment. In contrast to the rated operation, the no-load operation is also possible for initial commissioning in many applications.

The motor rotor resistance can only be adjusted exactly if the current motor speed is available. Thus, for this adjustment only applications are considered where a speed measurement is possible, even with a manual tachometer. If, under operating conditions (e.g. at rated load), the motor consumes more than the rated motor current indicated, an adjustment can also be executed by reducing the mutual motor inductance.



#### Note!

To execute the adjustment processes described in the following subchapters, the controller must always be enabled!

### 5.5.2.1 Motor power factor

Together with the rated motor current, the motor power factor ([C00091](#)) defines the motor magnetising current ([C00092](#)) and thus the current consumption of the controller in idle state.



#### Note!

The following adjustment of the motor power factor should be executed after the motor parameters have been determined and when the value set in [C00091](#) deviates more than 10 % from the data on the motor nameplate.

If the setting of the motor power factor in [C00091](#) is changed, the setting of the mutual motor inductance also changes in [C00079](#).

For the adjustment of the motor power factor, first the motor current in idle state at rated speed is determined in the control type "V/f control". Afterwards the motor power factor is set in the control type "Sensorless vector control" so that the motor magnetising current corresponds to the previously determined no-load current.



#### How to adjust the motor power factor:

1. If the controller is enabled, inhibit the controller, e. g. with the device command [C00002](#) = "41: Inhibit controller".
2. Select the control type VFCplus: V/f control" in [C00006](#).
3. Select setpoint speed 0 rpm
4. Enable controller.
5. Slowly increase setpoint speed to rated speed (no field weakening) and then keep it at rated speed constantly.
6. Take down the motor current displayed in [C00054](#).
7. Slowly reduce the setpoint speed to 0 rpm again.
8. inhibit inverter.
9. Go to [C00006](#) and select the "SLVC: Sensorless vector control" again.
10. Set Lh adjustment in [C02861](#) to 100 %.
11. Set the motor power factor ([C00091](#)) so that the following applies:  
motor magnetising current ([C00092](#))  $\approx$  motor current taken down before.
12. Save parameter set ([C00002](#) = "11: Save start parameters").

### 5.5.2.2 Motor stator resistance

For the adjustment of the motor stator resistance, first the motor current at standstill (without load of the motor) is compared to the motor magnetising current. Afterwards the setting of the motor stator resistance is changed step by step until the motor current stably reaches the motor magnetising current.



#### How to adjust the motor stator resistance:

1. Select setpoint speed 0 rpm or activate quick stop.
2. Enable controller.
3. Compare the motor current displayed in [C00054](#) with the motor magnetising current displayed in [C00092](#).
4. inhibit inverter.
5. If motor current > motor magnetising current:
  - Reduce the motor stator resistance stepwise in [C00084](#).If motor current < motor magnetising current:
  - Increase the motor stator resistance stepwise in [C00084](#).
6. Repeat steps 2 ... 5 until the following applies: Motor current  $\approx$  motor magnetising current.
7. Save parameter set ([C00002](#) = "11: Save start parameters").

### 5.5.2.3 Motor magnetising inductance

#### Adjustment at rated operation

This adjustment is executed at rated speed and a defined load (e.g. measuring brake) which serves to define the rated torque. A condition for the adjustment is to know the real load torque. The motor current is compared to the rated current. At rated load, these two values should be almost identical.

If an adjustment at rated operation is not possible, alternatively execute the adjustment at no-load operation (see the following section "Adjustment at no-load operation").



#### How to adjust the mutual motor inductance at rated operation:

1. Set the maximum current in [C00022](#) to 110 % of the rated motor current ([C00088](#)).
2. Select setpoint speed 0 rpm
3. Enable controller.
4. Slowly increase setpoint speed to rated speed (no field weakening) and then keep it at rated speed constantly.
5. Apply rated load to the motor.
6. Compare the motor current displayed in [C00054](#) with the rated motor current displayed in [C00088](#).
7. If motor current > rated motor current:
  - Reduce the mutual motor inductance stepwise and indirectly via the Lh adjustment in [C02861](#) until the following applies: motor current  $\approx$  rated motor current.
- If motor current < rated motor current:
  - Increase the mutual motor inductance stepwise and indirectly via the Lh adjustment in [C02861](#) until the following applies: motor current  $\approx$  rated motor current.
8. Unload the motor again and slowly reduce the setpoint speed to 0 rpm again.
9. inhibit inverter.
10. Save parameter set ([C00002](#) = "11: Save start parameters").

### Adjustment at no-load operation

If an adjustment at rated operation is not possible, alternatively execute the adjustment at no-load operation.

For the adjustment of the mutual motor inductance in no-load operation, first the motor current is compared to the motor magnetising current at a setpoint speed of approx. 75 % of the rated speed (without load of the motor). Afterwards the setting of the mutual motor inductance is changed step by step until the motor current just, but stably reaches the motor magnetising current.



#### How to adjust the mutual motor inductance at no-load operation:

1. Select setpoint speed 0 rpm
2. Enable controller.
3. Slowly increase the setpoint speed to approx. 75 % of the rated speed and keep this value constant.
  - If the controller oscillates, check the speed controller.
4. Compare the motor current displayed in [C00054](#) with the motor magnetising current displayed in [C00092](#).
5. If motor current > motor magnetising current:
  - Reduce the mutual motor inductance stepwise and indirectly via the Lh adjustment in [C02861](#) (based on 100 %) until the following applies:  
motor current < motor magnetising current
 If motor current << motor magnetising current:
  - Increase the mutual motor inductance stepwise and indirectly via the Lh adjustment in [C02861](#) (based on 100 %) until the following just applies:  
motor current < motor magnetising current
6. Slowly reduce the setpoint speed to 0 rpm again.
7. inhibit inverter.
8. Save parameter set ([C00002](#) = "11: Save start parameters").

#### 5.5.2.4 Motor rotor resistance

This adjustment is carried out at a setpoint speed of approx. 75 % of the rated speed and with a defined load (e. g. measuring brake). The precondition for the adjustment is that the actual speed is known (e. g. by the use of a manual tachometer). At constant setpoint speed first the actual speed is measured while the machine is unloaded. Afterwards the motor is loaded at the same setpoint speed until the rated torque is reached (rated current). The speed measured should preferably correspond in idle state and at rated speed.



##### How to adjust the motor rotor resistance:

1. Select setpoint speed 0 rpm
2. Enable controller.
3. Slowly increase the setpoint speed to approx. 75 % of the rated speed and keep this value constant.
4. Measure actual speed  $n_{Idle}$  (e.g. using a manual tachometer) and take it down.
5. Increase load of the motor until the motor current displayed in [C00054](#) corresponds to the rated current.
6. Measure actual speed  $n_{Load}$ .
7. If  $n_{Load} < n_{Idle}$ :
  - Reduce motor rotor resistance stepwise and indirectly via the  $R_r$  adjustment in [C02860](#) until the following applies:  $n_{Load} \approx n_{Idle}$ .
- If  $n_{Load} > n_{Idle}$ :
  - Increase motor rotor resistance stepwise and indirectly via the  $R_r$  adjustment in [C02860](#) until the following applies:  $n_{Load} \approx n_{Idle}$ .
8. Unload the motor again and slowly reduce the setpoint speed to 0 rpm again.
9. inhibit inverter.
10. Save parameter set ([C00002](#) = "11: Save start parameters").

### 5.5.3 Optimising the control mode

A manual optimisation of the controller settings may be required for very dynamic applications and in the field weakening range.



#### Note!

The processes for optimising the controller settings described in the following subchapters can only be executed while the drive is rotating and never when being at standstill!

For all optimisation processes the magnetisation phase has to be completed!

Based on the typical controller settings which are listed in the chapter "[Parameterising speed and torque controller](#)" in table [\[5-8\]](#), first the field feedforward control and the speed controller are optimised in the base speed range. Afterwards, the torque controller is optimised in the field weakening range.

For optimisation, a suitable speed ramp must be selected for the drive and the acceleration must be recorded, e.g. using the [Oscilloscope](#) function in »Engineer«. ([□ 585](#))

#### Short overview: Parameters for controller settings

Parameters	Info	Lenze setting	
		Value	Unit
<a href="#">C00070</a>	Speed controller gain	0.500	Nm/rpm
<a href="#">C00071</a>	Speed controller reset time	24.0	ms
<a href="#">C00985</a>	SLVC: Field controller gain	0.00	
<a href="#">C00986</a>	SLVC: Cross current controller gain	0.00	
<a href="#">C00987</a>	SLVC: Torque controller gain	0.5000	Hz/A
<a href="#">C00988</a>	SLVC: Torque controller reset time	10.00	ms

### 5.5.3.1 Optimising field feedforward control

To optimise the field feedforward control, the drive must be accelerated in the base speed range with slow setpoint ramps (e.g. acceleration time = 5 s) to speed values below the rated speed and then decelerated again.

- If the field current oscillates at the beginning of the acceleration and at the end of the deceleration (Current.dnActualDirectCurrent), these oscillations can be reduced by increasing the gain for the field current controller in [C00985](#).

Ch	Variable of the motor control	Unit	1/Div	Offset	Position
1	Speed.dnSpeedSetpoint (speed setpoint)	rpm	0.2k	0	-4
2	Speed.dnActualMotorSpeed (current speed)	rpm	0.2k	0	-4
3	Current.dnActualDirectCurrent (actual field current)	A	10	0	0
4	Current.dnQuadratureCurrentSet (cross current setpoint)	A	10	0	0
5	Current.dnActualQuadratureCurrent (actual cross current)	A	10	0	0

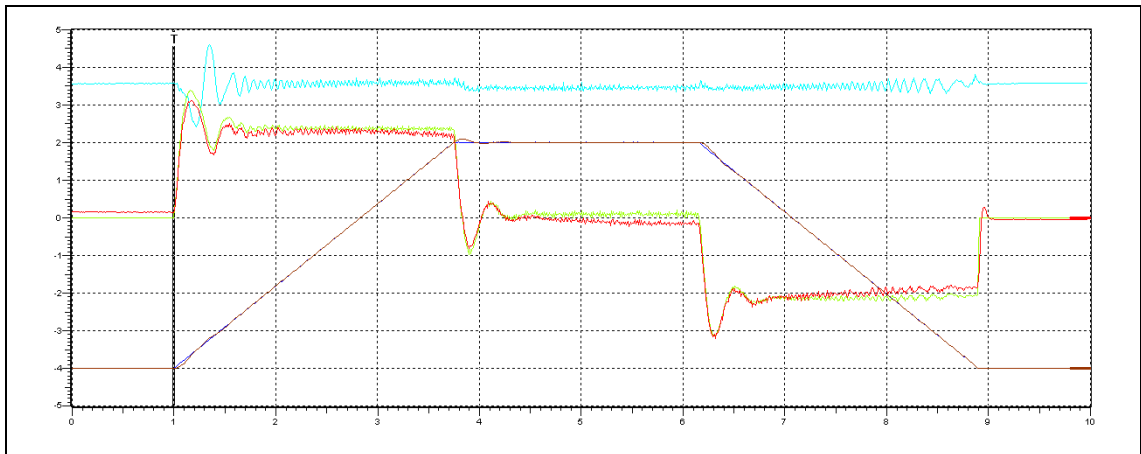

[5-9] Oscilloscope 1: speed ramp (motor 55 kw) – field controller gain = 0.00

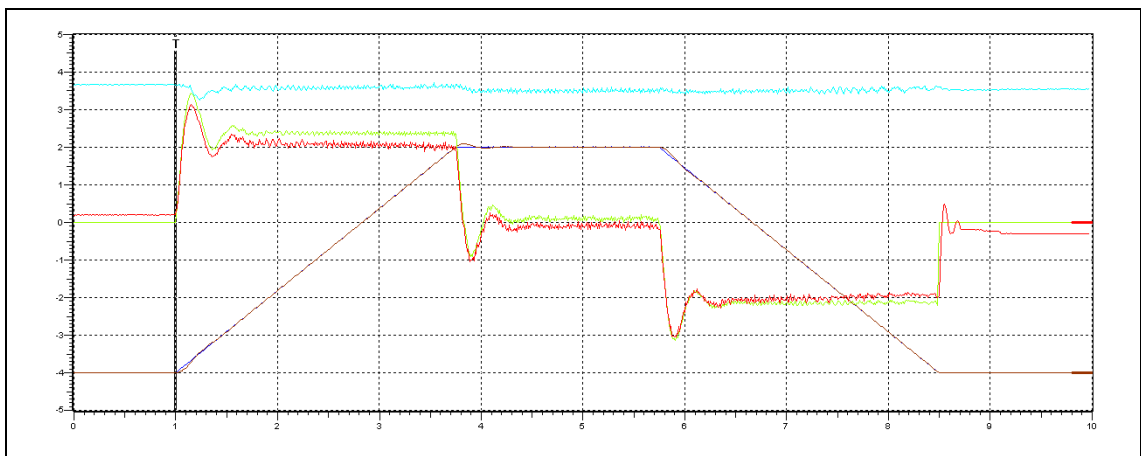

[5-10] Oscilloscope 2: speed ramp (motor 55 kw) – field controller gain = 2.00



### 5.5.3.2 Optimising the speed controller

To optimise the speed controller, the drive must be accelerated in the base speed range with slow setpoint ramps (e.g. acceleration time = 5 s) to speed values below the rated speed and then decelerated again.

#### Gain optimisation

The proportional gain  $V_p$  is selected under [C00070](#):

1. Increase [C00070](#) until the drive oscillates slightly (see picture [\[5-11\]](#)).
2. Reduce [C00070](#) until the drive runs stable again (see picture [\[5-12\]](#)).
3. Reduce [C00070](#) to approx. half the value.

#### Optimise the reset time

The reset time  $T_n$  is selected under [C00071](#):

1. Reduce [C00071](#) until the drive oscillates slightly.
2. Increase [C00071](#) until the drive is stable again.
3. Increase [C00071](#) to approx. double the value.

Ch	Variable of the motor control	Unit	1/Div	Offset	Position
1	Speed.dnSpeedSetpoint (speed setpoint)	rpm	0.2k	0	-4
2	Speed.dnActualMotorSpeed (current speed)	rpm	0.2k	0	-4
3	Current.dnActualDirectCurrent (actual field current)	A	10	0	0
4	Current.dnQuadratureCurrentSet (cross current setpoint)	A	10	0	0
5	Current.dnActualQuadratureCurrent (actual cross current)	A	10	0	0

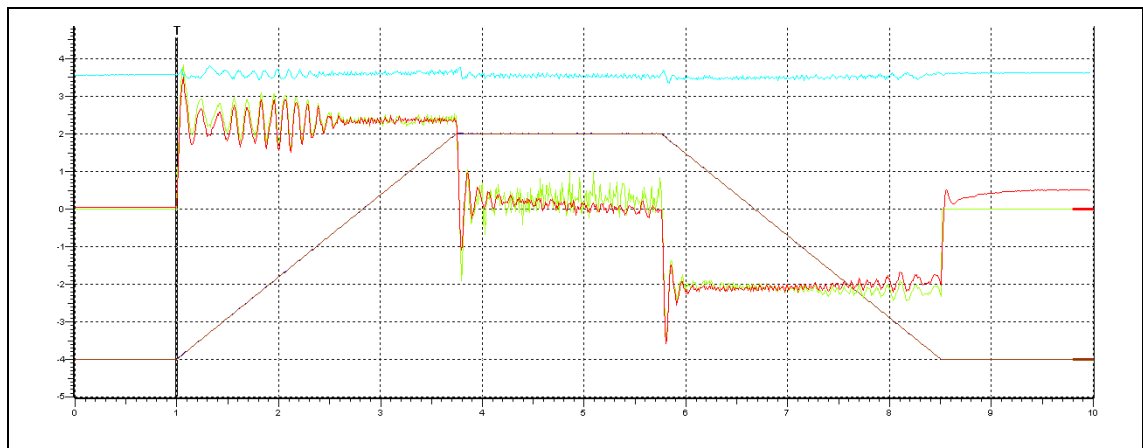

[5-11] Oscillogram 1: speed ramp (motor 55 kw) – speed controller gain = 15.49

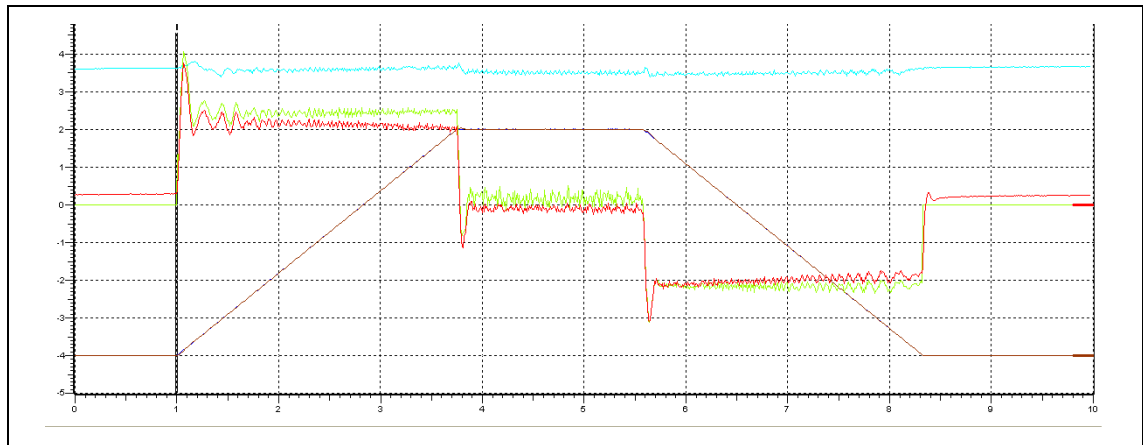

[5-12] Oscillogram 2: speed ramp (motor 55 kw) – speed controller gain = 7.49

### Setting of actual speed filter

In order to maximise the dynamics of the speed control loop, the actual speed filter should be operated with a time constant as low as possible ([C00497](#)). The lower the time constant the higher the gain of the speed controller. Since actual value filters have the task to dampen measuring errors or interference components, it must be found a compromise between filter task and the resulting delay.

If a Lenze motor is selected from the motor catalogue, a time constant is automatically preset in [C00497](#) which serves to operate the motor even with a faulty detection (e.g. in case of a bad shield connection).

When using EMC-compliant systems or high-quality encoders, you can reduce the preset time constant considerably. For this purpose, the running noise of the motor can be used for setting [C00497](#) at constant speed.

If this is not possible, e.g. due to a too loud environment or because the motor is too far away, the noise of the actual speed value or the setpoint torque value can be used for evaluation by means of the [Oscilloscope](#). Please observe that the speed controller gain  $V_p$  ([C00070](#)) is used for the torque setpoint.

### 5.5.3.3 Optimising torque controller

To optimise the torque controller a steep speed ramp is required which reaches into the field weakening range (e.g.  $1.2 \cdot$  rated speed). For this purpose, the drive must be operated at its current and voltage limit.



#### Stop!

Reduce the maximum current in [C00022](#) for this adjustment to approx. 130 % of the motor magnetising current ([C00092](#)) to prevent shocks on the drive!



#### Note!

If no field weakening operation is required, the adjustment must be executed in the base speed range.

The gain ([C00987](#)) and reset time ([C00988](#)) of the torque controller are to be set so that the actual cross current can preferably follow the cross current setpoint.

- If oscillations occur during the cross current (see illustration [\[5-13\]](#)), the gain ([C00987](#)) is to be reduced until the drive is stable again (see illustration [\[5-14\]](#)).
- Afterwards the reset time ([C00988](#)) can be reduced as long as the drive accelerates in a stable way.

Ch	Variable of the motor control	Unit	1/Div	Offset	Position
1	Speed.dnSpeedSetpoint (speed setpoint)	rpm	0.2k	0	-4
2	Speed.dnActualMotorSpeed (current speed)	rpm	0.2k	0	-4
3	Current.dnActualDirectCurrent (actual field current)	A	10	0	0
4	Current.dnQuadratureCurrentSet (cross current setpoint)	A	10	0	0
5	Current.dnActualQuadratureCurrent (actual cross current)	A	10	0	0

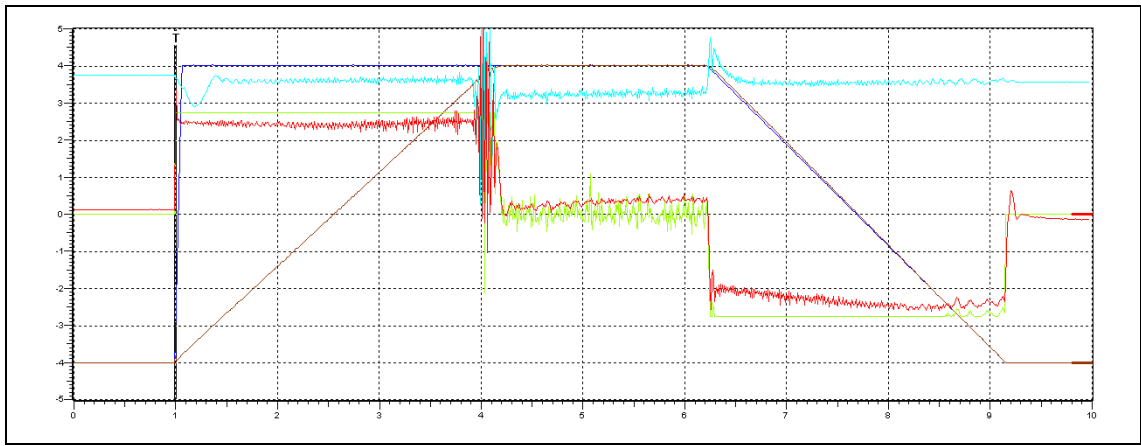

[5-13] Oscillogram 1: speed ramp (motor 55 kw) – torque controller gain = 0.0661

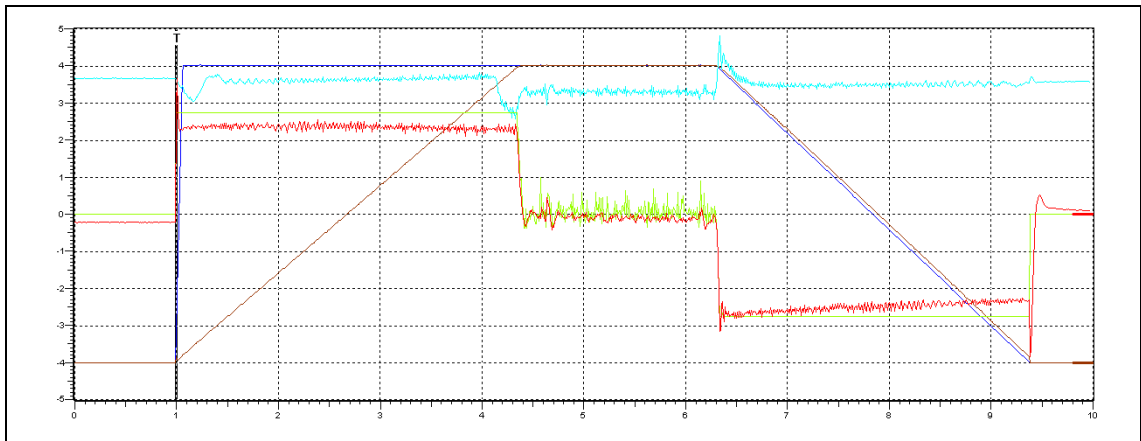

[5-14] Oscillogram 2: speed ramp (motor 55 kw) – torque controller gain = 0.0361

## 5.5.3.4 Optimise current controller

**Note!**

Only required for sensorless vector control if one of the following functions is used.

- [Flying restart function](#) (📖 212)
- [DC-injection braking](#) (📖 215)

In a test mode you can select current setpoint step-changes and optimise the parameter settings of the current controller (gain and reset time) by evaluating the step responses.

- The starting values for gain and reset time can be calculated with the following formula:

$$\text{Gain} = \frac{\text{Stator leakage inductance}}{340 \mu\text{s}}$$

$$\text{Reset time} = \frac{\text{Stator leakage inductance}}{\text{Stator resistance}}$$

**How to optimise the current controller in the test mode:**

1. If the controller is enabled, inhibit the controller, e. g. with the device command [C00002](#) = "41: Inhibit controller".
2. Activate one of the two following optimisation modes for the current controller:
  - [C00398](#) = "3: Current controller optimisation mode":  
After controller enable, the motor is supplied with current as long as the controller is enabled.
  - [From software version V7.0:](#)  
[C00398](#) = "4: Current controller optimisation mode pulse":  
The motor is supplied with voltage for 50 ms after controller enable. Due to this time limit, the load of the machine is reduced. Afterwards, the controller is inhibited automatically.
3. Select the effective value of the current setpoint step change under [C00022](#).
  - The peak value of the measurable motor current will be 1.41 times higher.
4. Enable the controller for a short time and measure the step response of the motor current in the motor phases using the oscilloscope and clamp-on ammeters or record the field-oriented direct-axis current using the [Oscilloscope](#) function in »Engineer«. (📖 585)
  - Variable of the motor control to be recorded:  
*Current.dnActualDirectCurrent* (field-oriented direct-axis current)

## 5. Evaluate the step response:

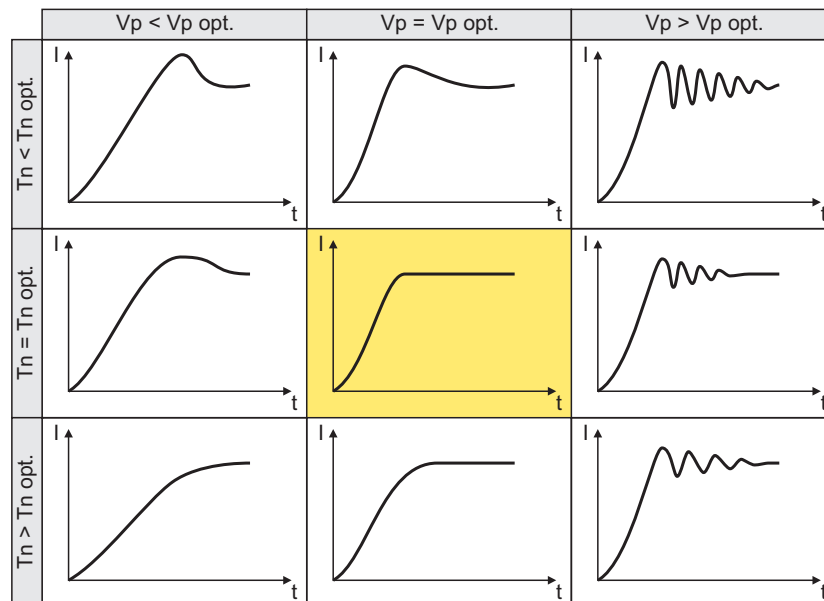

6. Change the gain  $V_p$  under [C00075](#) and the reset time  $T_n$  under [C00076](#).
7. Repeat steps 4 ... 6 until the optimum step response of the motor current is reached.
  - In the optimised state the current rise time typically is 0.5 ... 1 ms.
8. After the optimisation has been completed, deactivate the test mode again ([C00398](#) = "0: Test mode deactivated").
9. Save parameter set ([C00002](#) = "11: Save start parameters").

5.5.4 Signal flow

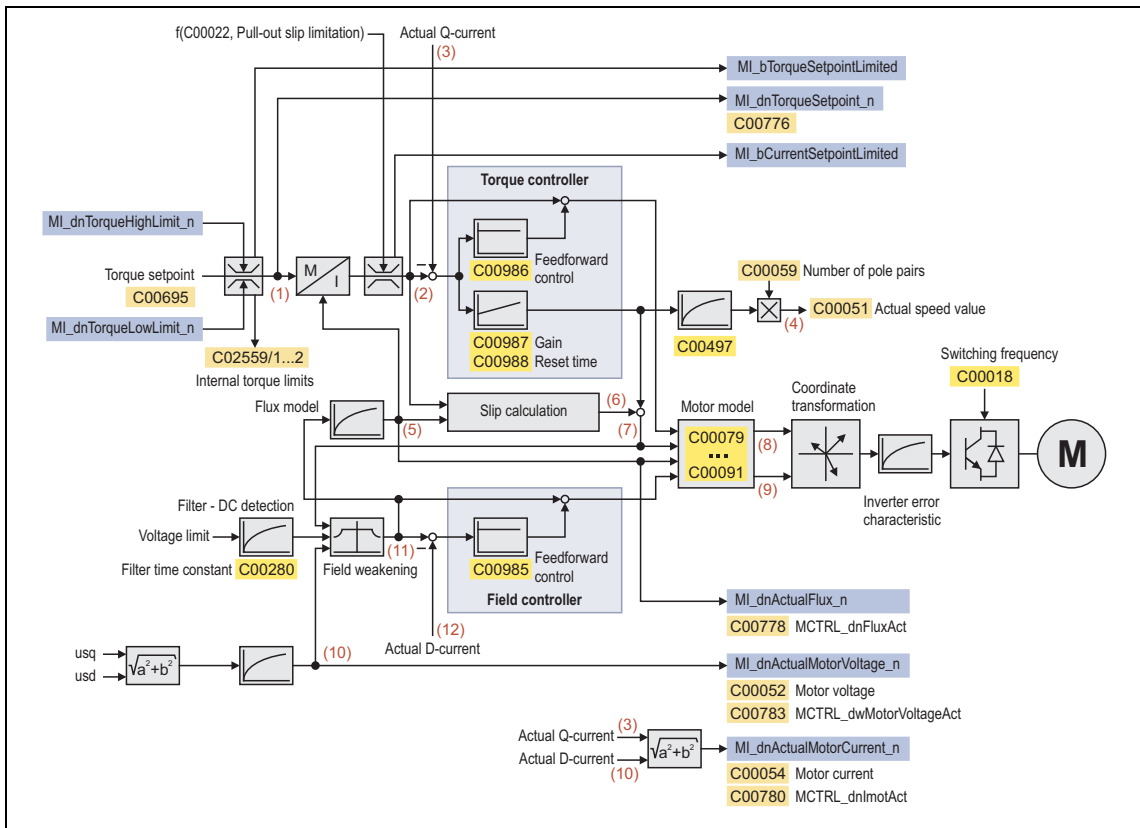

[5-15] Signal flow - sensorless vector control

Internal variables of the motor control (oscilloscope signals)

- The red numbers in brackets listed in the signal flow stand for internal variables of the motor control, which you can record by means of the [Oscilloscope](#) for purposes of diagnostics and documentation. (585)

No.	Variable of the motor control	Meaning
(1)	Torque.dnTorqueSetpoint	Torque setpoint
(2)	Current.dnQuadratureCurrentSet	Q current setpoint
(3)	Current.dnActualQuadratureCurrent	Actual Q current
(4)	Speed.dnActualMotorSpeed	Actual speed value
(5)	Common.dnActualFlux	Actual flux value
(6)	Frequency.dnActualSlipFrequency	Actual slip frequency
(7)	Frequency.dnActualRotatingFieldFrequency	Current field frequency
(8)	Voltage.dnQuadratureVoltage	Q voltage
(9)	Voltage.dnDirectVoltage	D voltage
(10)	Voltage.dnActualMotorVoltage	Current motor voltage
(11)	Current.dnDirectCurrentSet	D current setpoint
(12)	Current.dnActualDirectCurrent	Actual D current

### 5.6 V/f control (VFCplus)

This function extension is available from software version V3.0!

If this motor control mode is set in [C00006](#), the output voltage of the controller follows a firmly defined characteristic.



#### Note!

The operation of vertical drives/hoists is only supported up to 55 kW by the V/f control!

#### 5.6.1 Basic settings

After the motor and controller have been optimally adjusted to each other, the "initial commissioning steps" described in the following table are sufficient for a simple characteristic control.

- Detailed information on the individual steps can be found in the following subchapters.

Initial commissioning steps	
1	<a href="#">Defining the V/f characteristic.</a> (📖 185)
2.	<a href="#">Setting the voltage boost.</a> (📖 186)
3	<a href="#">Parameterising load adjustment.</a> (📖 188)
4	<a href="#">Activating voltage vector control.</a> (📖 189) <ul style="list-style-type: none"> <li>• The <i>Voltage Vector Control (VCC)</i>, which can be activated, serves to provide a torque at low field frequencies. This task is executed by a current controller the output voltage of which is added to the voltage from the characteristic.</li> </ul>
5	<a href="#">Defining the current limit (Imax controller).</a> (📖 190)
6	Additional "flying restart" function: <ul style="list-style-type: none"> <li>• In the Lenze setting, this parameterisable additional function is activated.</li> <li>• If the flying restart function is not required, deactivate this function. ▶ <a href="#">Flying restart function</a> (📖 212)</li> </ul> <div style="text-align: center;">  </div> <p><b>Only deactivate the flying restart if it is ensured that the drive is always at standstill in the case of controller enable!</b></p>
7	Additional "DC-injection braking" function: <ul style="list-style-type: none"> <li>• In the Lenze setting, this parameterisable additional function is deactivated.</li> <li>• If DC-injection braking is required, activate this function. ▶ <a href="#">DC-injection braking</a> (📖 215)</li> </ul>



#### Tip!

How to optimise the control behaviour and adjust it to the concrete application is described in the chapter "[Optimising the control mode](#)". (📖 191)

Parameterisable additional functions are described correspondingly in the chapter "[Parameterisable additional functions](#)". (📖 203)



### 5.6.1.1 Defining the V/f characteristic

#### Linear/square-law characteristic

[C00950](#) serves to select the shape of the characteristic to adjust the characteristic to different load profiles:

- Linear characteristic for drives with constant load torque over the speed.
- Square-law characteristic for drives with a linear or square-law load torque over the speed:
  - Square-law V/f characteristics are mostly used in centrifugal pump and fan drives. However, it must be checked in each individual case if your pump or fan drive can be used in this operating mode!
  - If your pump or fan drive is not suitable for operation with a square-law V/f characteristic, you have to use the linear or user-definable V/f characteristic or the sensorless vector control instead of the V/f control.

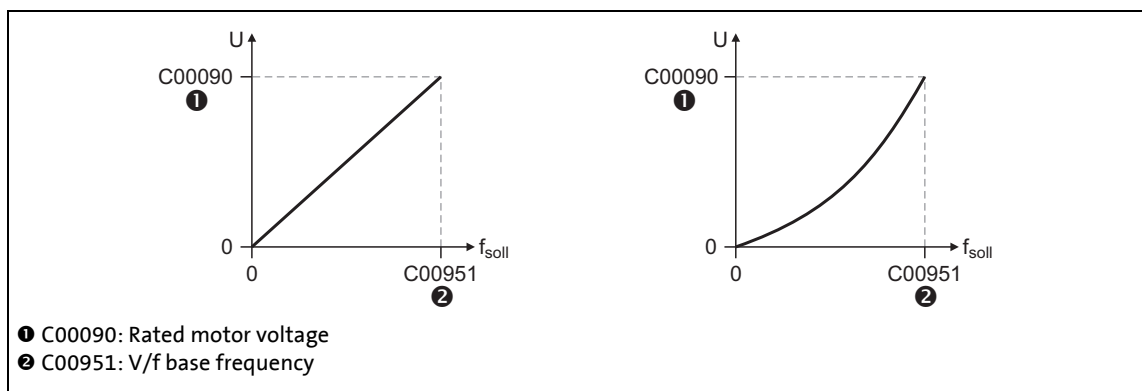

[5-16] Linear/square-law V/f characteristic

- The calculation of the characteristic considers the rated motor voltage ([C00090](#)) and the V/f base frequency ([C00951](#)).

#### Short overview: Parameters for V/f characteristic

Parameters	Info	Lenze setting	
		Value	Unit
<a href="#">C00950</a>	VFC: V/f characteristic shape	Linear (V/f)	
<a href="#">C00951</a>	VFC: V/f base frequency	50	Hz
<a href="#">C00952/1...11</a>	VFC: Frequency interpol. point n	<a href="#">▶ Defining a user-defined V/f characteristic</a> (□ 192)	
<a href="#">C00953/1...11</a>	VFC: Voltage interpol. point n		
<a href="#">C00954/1...11</a>	VFC: Activat. interpol. point n		

### 5.6.1.2 Setting the voltage boost

[C00960](#) and the *MI\_dnBoostSet\_n* input of the motor interface serve to define a constant, load independent voltage boost at low speeds (below the V/f rated frequency) or at motor standstill to optimise the starting performance.



#### Stop!

If the motor is operated at standstill for a longer time - especially in case of smaller motors - the motor can be destroyed by overtemperature!

- Connect the thermal contact (NC contact), PTC, or KTY of the motor and activate the motor temperature monitoring of the controller.
- Operate self-ventilated motors with a blower, if required.



#### Note!

When device types > BF7 are used, the voltage boost only functions in a restricted way due to the hardware properties!

Depending on the required starting torque, the voltage boost must be set so that the required motor current will be available after controller enable (starting current  $\sim V_{\min}$ ).



#### Tip!

The required voltage can be calculated by multiplying the stator resistance by the rated magnetising current:

$$U_{\min} = R_S \cdot I_{mN}$$

Optionally, the voltage can be determined empirically by increasing the value for the voltage boost until the rated magnetising current flows.

Calculate voltage boost $V_{\text{Boost}}$	
$U_{\text{Boost}} = MI\_dnBoostSet\_n \cdot \frac{1000V}{100\%} + C00960$	
MI_dnBoostSet_n	The value for the <i>MI_dnBoostSet_n</i> input is a voltage related to 1000 V given in [%]. <a href="#">▶ Internal interfaces   "LS_MotorInterface" system block</a>
C00960	In <a href="#">C00960</a> , the voltage must be set directly in [V]. Notes: <ul style="list-style-type: none"> <li>• Only positive voltage values can be selected, negative values are limited to 0 V.</li> <li>• The voltages in <a href="#">C00960</a> and the relative <i>MI_dnBoostSet_n</i> value are to be understood as peak values of the phase voltage.</li> </ul>

The resulting voltage  $V$  is calculated from the geometrical addition of  $V_{\text{Boost}}$  and the characteristic voltage:

$$U = \sqrt{U_{\text{Characteristic}}^2 + U_{\text{Boost}}^2}$$

# 5 Motor interface

## 5.6 V/f control (VFCplus)

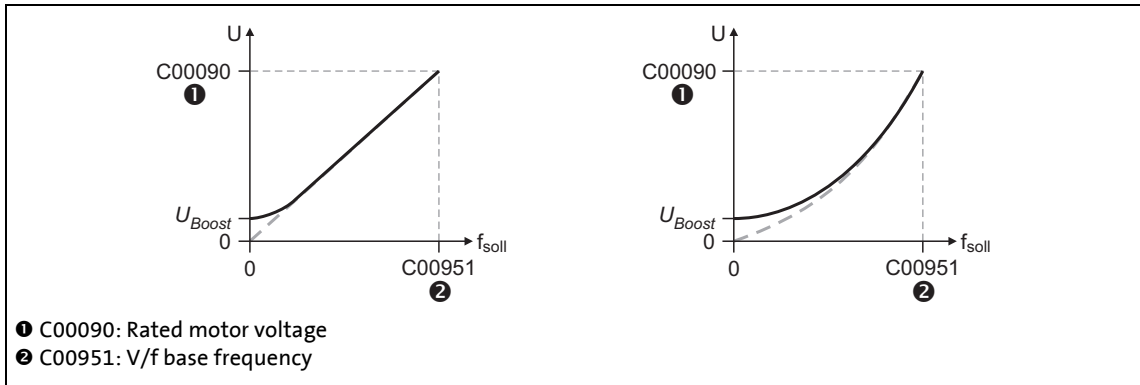

[5-17] Voltage boost at linear/square-law V/f characteristic

### Short overview: Parameters for voltage boost

Parameters	Info	Lenze setting	
		Value	Unit
<a href="#">C00960</a>	VFC: V/f voltage boost	0	V



#### Tip!

For magnetising the motor, consider a sufficient time from the controller enable to the start of the speed ramp function generator.

- The bigger the motor the longer the time required for magnetisation. A motor with a power of 90 kW requires up to 2 seconds.

### 5.6.1.3 Parameterising load adjustment

[C00962](#) serves to parameterise a load adjustment in [%] proportionally to the rated torque to obtain a correspondingly "rigid" drive behaviour even after the starting action.

- When starting torque = rated torque, a load adjustment of 50 % is suitable for most applications.



#### Stop!

If the load adjustment is too high, the motor current may increase in idle state and the motor may overheat!

The [C00961](#) parameter serves to adjust the characteristic depending on the load at CW and CCW rotation:

Setting in C00961	Info
0: CW rotation in motor mode/CCW rotation in motor mode	The motor operates in motor mode in both directions.
1: CW rotation in motor mode/CCW rotation in generator mode	Application example: Hoist without counterweight
2: CW rotation in generator mode/CCW rotation in motor mode	Application example: Dancer-controlled unwinder

#### Short overview: Parameters for load adjustment

Parameters	Info	Lenze setting	
		Value	Unit
<a href="#">C00961</a>	VFC: Load - cw/ccw-operation	CW: mot. / CCW: mot.	
<a href="#">C00962</a>	VFC: Load adjustment	20.00	%

#### 5.6.1.4 Activating voltage vector control

The *Voltage Vector Control* (VCC), which can be activated, is an alternative to the voltage boost. The voltage vector control is used if a high starting torque has to be ensured. The voltage vector control ensures that the motor current required for this purpose is available in the zero speed range.



#### Note!

A disadvantage of the voltage vector control is the increased current at low speeds. This causes higher losses and thus an increased heating of the machine.

The voltage vector control is activated by defining a current setpoint in [C00957](#) and can be deactivated again by setting "0.0 A".

- The voltage vector control is additive to the voltage boost.
  - ▶ [Setting the voltage boost](#) (186)
- When the current setpoint is defined, provide a reserve of 20 % to prevent a motor stalling caused by sudden additional loads.
- Example for starting torque = rated motor torque:  
The current setpoint must be parameterised in [C00957](#) to approx. 120 % of the load current.

#### Setting of the controller parameters

For the gain ([C00958](#)) and the reset time ([C00959](#)), accept the values that have been detected for the current controller gain ([C00075](#)) and reset time ([C00076](#)) in the test mode. ▶ [Optimise current controller](#) (196)

Since the voltage vector control controls the current value which has a higher background noise due to its calculation, the reset time might possibly be increased.

#### Short overview: Parameters for voltage vector control

Parameters	Info	Lenze setting	
		Value	Unit
<a href="#">C00957</a>	VFC: VVC current setpoint	0.00	A
<a href="#">C00958</a>	VFC: VVC gain	0.00	V/A
<a href="#">C00959</a>	VFC: VVC reset time	2000.00	ms



#### Tip!

For controllers with a power > 55 kW we recommend to use the voltage vector control for horizontal drives for improving the smooth running characteristics.

### 5.6.1.5 Defining the current limit (Imax controller)

The current limit for the I<sub>max</sub> controller is defined by the maximum current which must be set in [C00022](#). If the motor current exceeds the value set in [C00022](#), the I<sub>max</sub> controller gets active.

- The I<sub>max</sub> controller changes the field frequency so that the motor current does not exceed the current limit. In motor mode, the frequency is reduced and in generator mode it is increased.
- Gain and reset time of the I<sub>max</sub> controller can be parameterised in [C00963](#) and [C00964](#).

#### Short overview: Parameters for I<sub>max</sub> controller

Parameters	Info	Lenze setting	
		Value	Unit
<a href="#">C00022</a>	Maximum current	0.00	A
<a href="#">C00963</a>	VFC: Gain - I <sub>max</sub> controller	0.001	Hz/A
<a href="#">C00964</a>	VFC: Reset time - I <sub>max</sub> controller	100.0	ms

#### Optimising the I<sub>max</sub> controller

- If oscillations occur during operation at the current limit, the I<sub>max</sub> controller has to be decelerated:
  - Reduce gain ([C00963](#))
  - Increase reset time ([C00964](#))
- If the I<sub>max</sub> controller does not operate fast enough after having exceeded the current limit, it must be accelerated:
  - Increase gain ([C00963](#))
  - Reduce reset time ([C00964](#)).

### 5.6.2 Optimising the control mode

The "optimisation steps" given in the following table serve to further optimise the control behaviour of the V/f control and adjust it to the concrete application.

- Detailed information on the individual steps can be found in the following subchapters.

Optimisation steps	
1	<a href="#">Defining a user-defined V/f characteristic.</a> (📖 192) <ul style="list-style-type: none"><li>• Individual adjustment of the motor magnetisation to the concrete application if linear and square-law characteristics are not suitable.</li></ul>
2.	<a href="#">Parameterising slip compensation.</a> (📖 193)
3	<a href="#">Parameterising oscillation damping.</a> (📖 194)
4	When the flying restart function is used: Optimise flying restart process. ▶ <a href="#">Flying restart function</a> (📖 212)
5	<a href="#">Optimise current controller.</a> (📖 196) <ul style="list-style-type: none"><li>• Only required if one of the following functions is used:<ul style="list-style-type: none"><li>• <a href="#">Voltage vector control</a> (📖 189)</li><li>• <a href="#">Flying restart function</a> (📖 212)</li><li>• <a href="#">DC-injection braking</a> (📖 215)</li></ul></li></ul>
6	Save »Engineer« project.

### 5.6.2.1 Defining a user-defined V/f characteristic

To individually adjust the motor magnetisation to the real application, a user-definable characteristic can be selected in [C00950](#) if the linear and square-law characteristic are not suitable.

- The interpolation points (voltage/frequency values) of this characteristic are selected via the 11 subcodes of [C00952](#) and [C00953](#).
- If less interpolation points are required, the interpolation points that are not needed have to be deactivated via the subcodes of [C00954](#).
- In the Lenze setting the 11 grid points represent a linear characteristic:

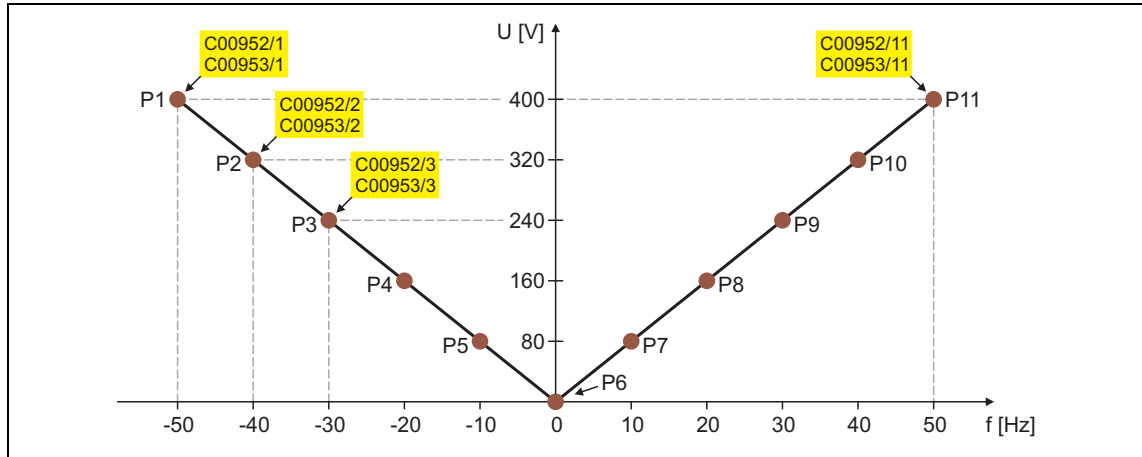

	P1	P2	P3	P4	P5	P6	P7	P8	P9	P10	P11
<b>V</b>	400 V	320 V	240 V	160 V	80 V	0 V	80 V	160 V	240 V	320 V	400 V
<b>f</b>	-50 Hz	-40 Hz	-30 Hz	-20 Hz	-10 Hz	0 Hz	10 Hz	20 Hz	30 Hz	40 Hz	50 Hz

[5-18] User-definable characteristic (Lenze setting)



# 5 Motor interface

## 5.6 V/f control (VFCplus)

### 5.6.2.2 Parameterising slip compensation

The slip compensation serves to automatically compensate a load-dependent speed loss. In order that the slip compensation can operate correctly, the rated slip of the motor is required. This is calculated from the rated frequency ([C00089](#)) and the rated speed ([C00087](#)), thus both parameters must be parameterised correctly.

- A percentage adjustment of the calculated slip can be made in [C00965](#), e.g. when the real motor data deviate from the data given on the nameplate. A value of 100 % in [C00965](#) corresponds to the rated slip of the machine.
- The time behaviour of the slip compensation can be parameterised in [C00966](#).

#### Short overview: Parameters for slip compensation

Parameters	Info	Lenze setting	
		Value	Unit
<a href="#">C00965</a>	VFC: Gain - slip compensation	0.00	%
<a href="#">C00966</a>	VFC: Time const. slip comp.	2000	ms

### 5.6.2.3 Parameterising oscillation damping

The oscillation damping serves to reduce the oscillations during no-load operation which are caused by energy oscillating between the mechanical system (mass inertia) and the electrical system (DC bus). Furthermore, the oscillation damping can also be used to compensate resonances.



#### Note!

Observe the following restrictions:

- Oscillations occurring sporadically cannot be damped.
- Damping is possible only for constant oscillations at a steady-state operating point.
- Oscillation damping is not suitable for oscillations occurring during dynamic processes (e.g. accelerations or load changes).

#### Job title

The determination of the oscillation is based on the active current. In order to obtain the alternating component of the active current, this current is differentiated. This signal is then passed through a PT1 filter.

- The base frequency of the PT1 filter has to be set in such a way that the oscillation can be damped and higher-frequency components are filtered out of the signal. For this purpose the time constant ([C00968](#)) is used.
- [C00967](#) serves to parameterise the gain of the oscillation signal. The maximum amplitude of the frequency change determined by the oscillation damping is set via [C00969](#).
- Oscillation damping is only active if the setpoint speed is greater than 10 rpm and the DC-bus voltage exceeds a value of 100 V.
- In the lower speed range, the oscillation damping may have a negative impact on the concentricity factor.
  - Therefore from software version V5.0 a ramp end frequency can be set in [C00970](#), up to which the gain of the oscillation damping ([C00967](#)) from 10 rpm is slowly increased with increasing rotational frequency.

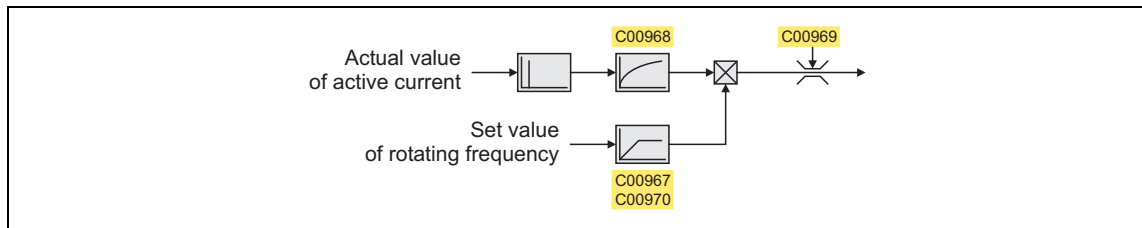

### Identification of the oscillation

Before the oscillation damping can be parameterised, the oscillation has to be identified. One way is to examine the motor current while oscillation damping is switched off ([C00967](#) = 0 %). At steady-state operation, a constant current flows. If the drive oscillates, these oscillations are also visible on the motor current. It is therefore possible to determine the frequency and the amplitude of the oscillation from the alternating component of the motor current. In the following, this alternating component is referred to as "current oscillation".

### Parameter setting

- The time constant ([C00968](#)) is determined from the reciprocal value of twice the frequency of the current oscillation:

$$\text{Time constant} = \frac{1}{2 \cdot \text{Oscillation frequency}}$$

- The gain factor ([C00967](#)) is calculated with the following formula based on the relationship between the amplitude of the current oscillation and the maximum device current:

$$\text{Gain} = \frac{\text{Current amplitude}}{\sqrt{2} \cdot \text{Maximum device current (C00789)}} \cdot 100 \%$$

- The maximum oscillation frequency ([C00969](#)) serves to the absolute limitation of the oscillation frequency calculated before it is added to the field frequency. It can be derived from the amplitude of the current oscillation, the rated motor current, and the slip frequency of the motor connected:

$$\text{Max. frequency} = \frac{2 \cdot \text{Amplitude of the current oscillation}}{\text{Rated motor current}} \cdot \text{Rated slip frequency}$$

- From software version V5.0:** The ramp end frequency ([C00970](#)) defines the rotational frequency from which the gain factor is to have reached its nominal value ([C00967](#)).
  - The ramp end frequency refers to the rated motor frequency in percent ([C00089](#)).
  - Below a speed of 10 rpm, the oscillation damping remains deactivated.
  - For machines with a power greater than 55 kW a ramp end frequency of 20 % is recommended.

### Short overview: Parameters for oscillation damping

Parameters	Info	Lenze setting	
		Value	Unit
<a href="#">C00967</a>	VFC: Gain - oscillation damping	20	%
<a href="#">C00968</a>	VFC: Time const. - oscill. damp.	5	ms
<a href="#">C00969</a>	VFC: Limitation - oscillation damping	0.2	Hz
<a href="#">C00970</a>	VFC: Ramp end freq. - oscillation damping	0	%

## 5.6.2.4 Optimise current controller

**Note!**

Only required if one of the following functions is used:

- [Voltage vector control](#) (📖 189)
- [Flying restart function](#) (📖 212)
- [DC-injection braking](#) (📖 215)

In a test mode you can select current setpoint step-changes and optimise the parameter settings of the current controller (gain and reset time) by evaluating the step responses.

- The starting values for gain and reset time can be calculated with the following formula:

$$\text{Gain} = \frac{\text{Stator leakage inductance}}{340 \mu\text{s}}$$

$$\text{Reset time} = \frac{\text{Stator leakage inductance}}{\text{Stator resistance}}$$

**How to optimise the current controller in the test mode:**

1. If the controller is enabled, inhibit the controller, e. g. with the device command [C00002](#) = "41: Inhibit controller".
2. Activate one of the two following optimisation modes for the current controller:
  - [C00398](#) = "3: Current controller optimisation mode":  
After controller enable, the motor is supplied with current as long as the controller is enabled.
  - [From software version V7.0:](#)  
[C00398](#) = "4: Current controller optimisation mode pulse":  
The motor is supplied with voltage for 50 ms after controller enable. Due to this time limit, the load of the machine is reduced. Afterwards, the controller is inhibited automatically.
3. Select the effective value of the current setpoint step change under [C00022](#).
  - The peak value of the measurable motor current will be 1.41 times higher.
4. Enable the controller for a short time and measure the step response of the motor current in the motor phases using the oscilloscope and clamp-on ammeters or record the field-oriented direct-axis current using the [Oscilloscope](#) function in »Engineer«. (📖 585)
  - Variable of the motor control to be recorded:  
*Current.dnActualDirectCurrent* (field-oriented direct-axis current)

## 5. Evaluate the step response:

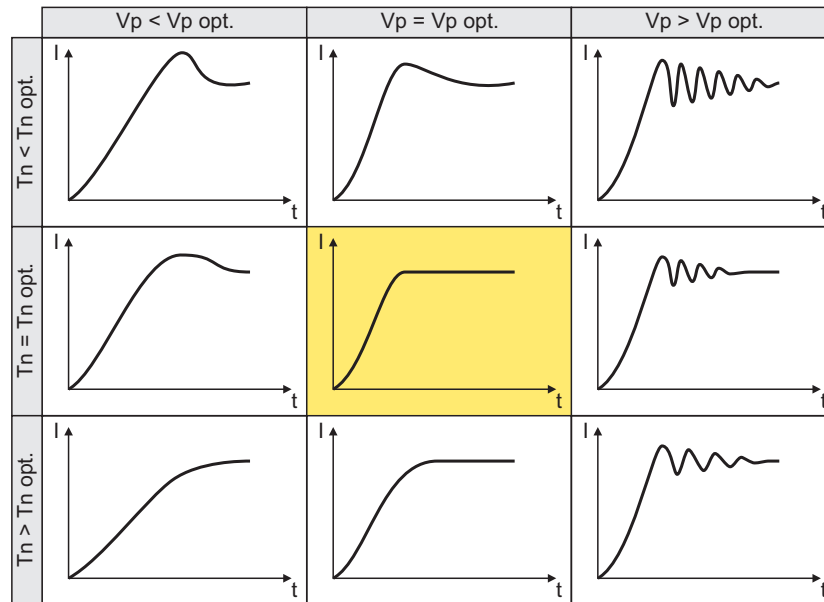

6. Change the gain  $V_p$  under [C00075](#) and the reset time  $T_n$  under [C00076](#).
7. Repeat steps 4 ... 6 until the optimum step response of the motor current is reached.
  - In the optimised state the current rise time typically is 0.5 ... 1 ms.
8. After the optimisation has been completed, deactivate the test mode again ([C00398](#) = "0: Test mode deactivated").
9. If the  $I_{min}$  control is used, both calculated controller parameters can also be used for the  $I_{min}$  controller:
  - [C00075](#) → [C00958](#) ( $I_{min}$  controller: gain)
  - [C00076](#) → [C00959](#) ( $I_{min}$  controller: reset time)
10. Save parameter set ([C00002](#) = "11: Save start parameters").

### 5.6.2.5 Optimising pull-out slip limitation

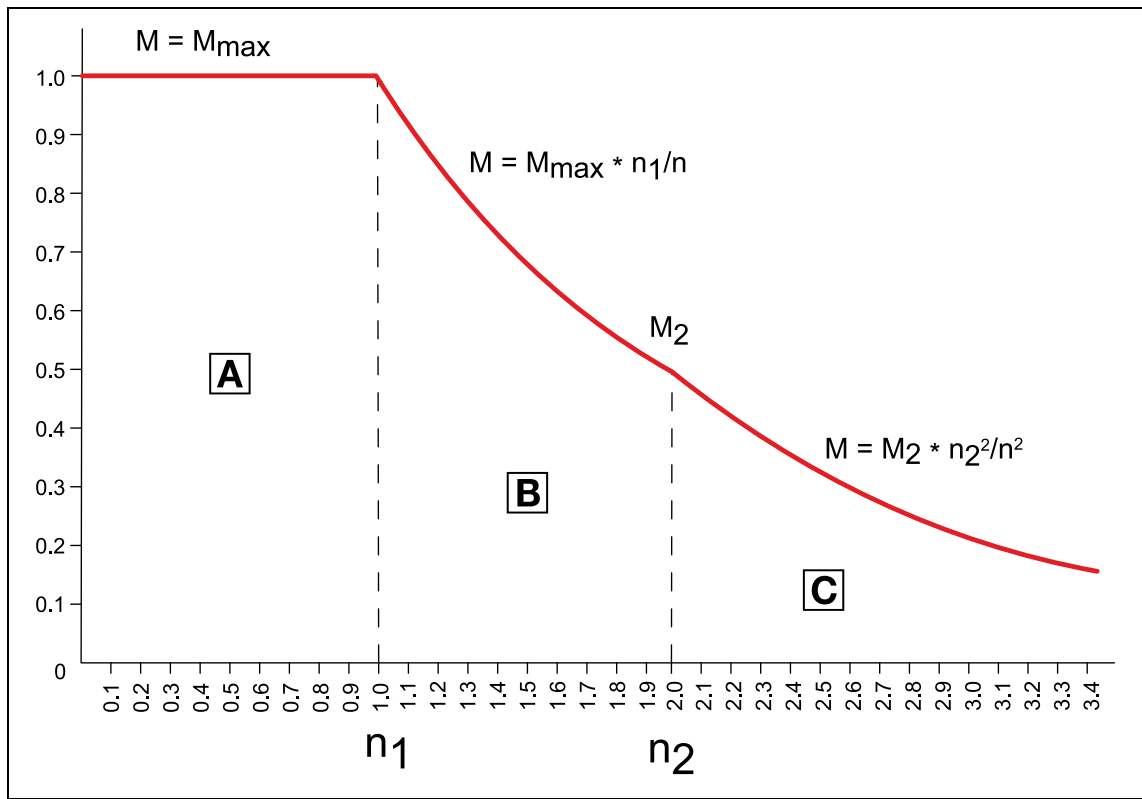

[5-19] Speed/torque curve of the asynchronous motor with two field weakening ranges **B** and **C**

The operating range of an asynchronous motor consists of the voltage control range **A** and the field weakening range. The field weakening range again is divided into two ranges:

- In the first range **B**, the power can be kept constant without causing motor stalling.
- The second field weakening range **C** is characterised by the fact that the maximum permissible stator current (defined via [C00022](#) "Maximum current") is reduced to prevent motor stalling.

The override point ( $n_2, M_2$ ) can be influenced via [C00980](#) ("VFC: Override point of field weakening"). If the motor stalls in the field weakening range, the override point ( $n_2, M_2$ ) can be adjusted by decreasing [C00980](#) so that motor stalling is avoided.

If the motor does not provide sufficient torque in the field weakening range, [C00980](#) must be increased.

5.6.3 Signal flow

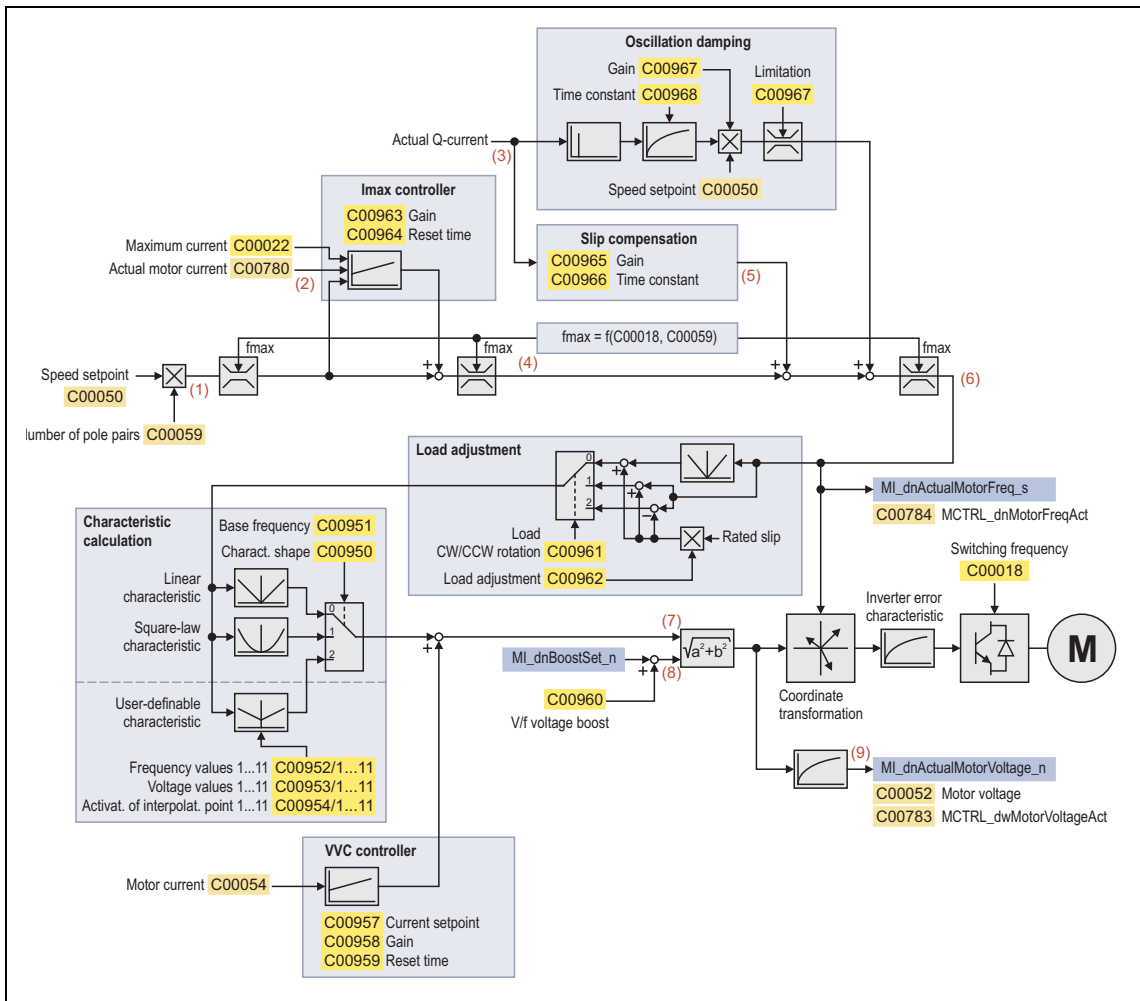

[5-20] Signal flow - V/f control

Internal variables of the motor control (oscilloscope signals)

- The red numbers in brackets listed in the signal flow stand for internal variables of the motor control, which you can record by means of the [Oscilloscope](#) for purposes of diagnostics and documentation. (🔗 585)

No.	Variable of the motor control	Meaning
(1)	Speed.dnSpeedSetpoint	Speed setpoint
(2)	Current.Current.dnActualMotorCurrent	Actual motor current
(3)	Current.dnActualQuadratureCurrent	Actual Q current
(4)	Speed.dnActualMotorSpeed	Current motor speed
(5)	Frequency.dnActualSlipFrequency	Actual slip frequency
(6)	Frequency.dnActualRotatingFieldFrequency	Current field frequency
(7)	Voltage.dnOutputQuadratureVoltage	Q voltage
(8)	Voltage.dnOutputDirectCurrentCtrl	D voltage
(9)	Voltage.dnActualMotorVoltage	Current motor voltage

# 5 Motor interface

## 5.7 V/f control (VFCplus)

### 5.7 V/f control (VFCplus)

This function extension is available from software version V3.0!



#### Note!

The descriptions in chapter "[V/f control \(VFCplus\)](#)" also apply to the V/f control. ([184](#))  
When this motor control mode is used, the operation can be continued if the encoder fails. For this, the encoder monitoring must be parameterised to "Warning". If the encoder fails, the speed controller is "frozen" so that the slip correction via the speed controller is maintained.

For the closed loop V/f control, the speed controller (also called "slip regulator") also has to be parameterised for the speed feedback.

- [C00971](#) serves to define the influence of the speed controller in [%] with regard to the reference speed of the motor ([C00011](#)). If the influence is adjusted to the slip expected under normal operating conditions, the motor cannot accelerate in an uncontrolled way when the encoder fails.
- To activate the speed controller, parameterise the gain ([C00972](#)) and the reset time ([C00973](#)).

#### Short overview: Parameters for speed controller

Parameters	Info	Lenze setting	
		Value	Unit
<a href="#">C00971</a>	VFC: Influence - speed controller	10.00	%
<a href="#">C00972</a>	VFC: Gain - speed controller	0.000	Hz/rpm
<a href="#">C00973</a>	VFC: Reset time - speed controller	6000.0	ms



5.7.1 Signal flow

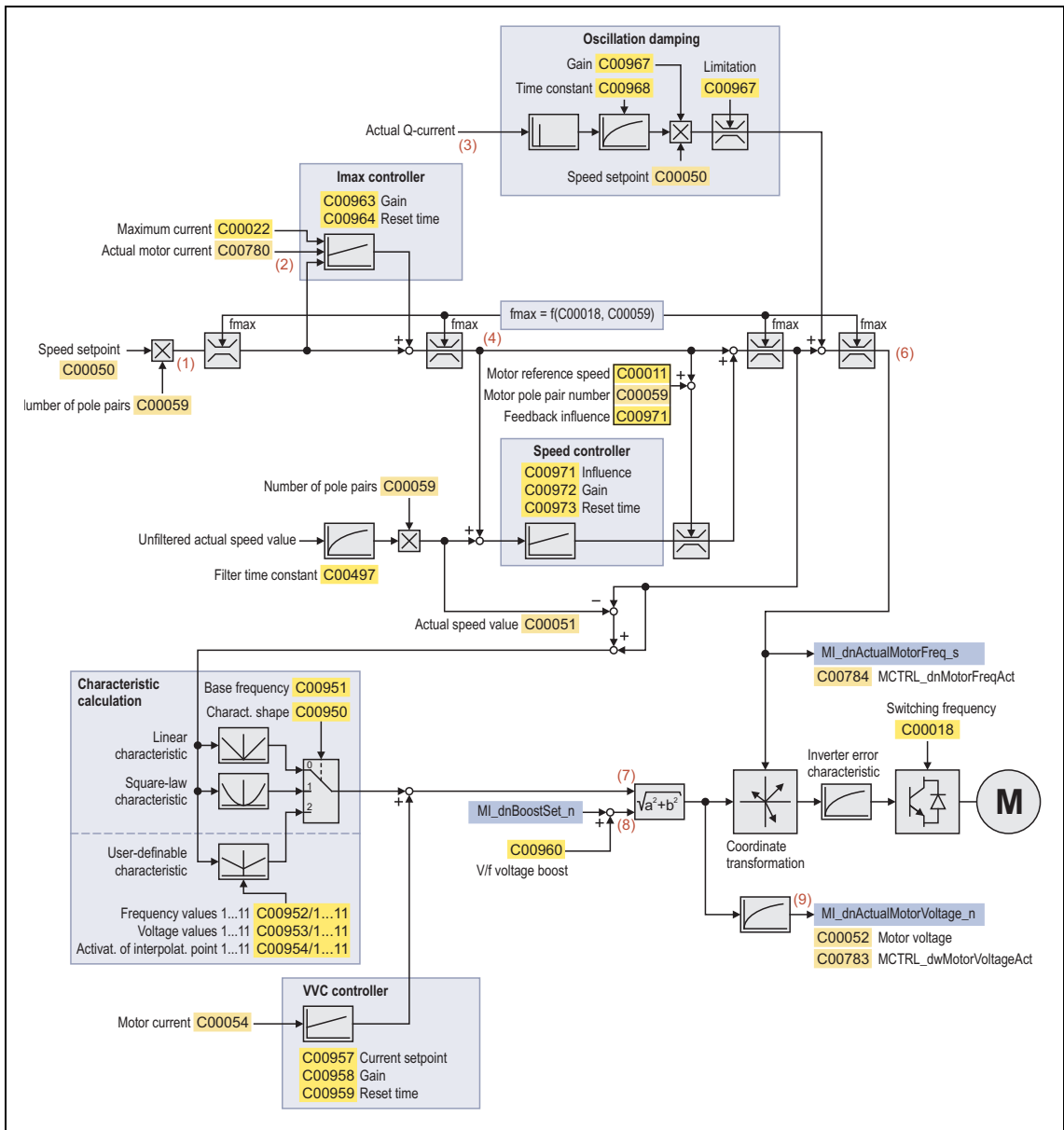

[5-21] Signal flow for closed loop V/f control

# 5 Motor interface

## 5.7 V/f control (VFCplus)

---

### Internal variables of the motor control (oscilloscope signals)

- The red numbers in brackets listed in the signal flow stand for internal variables of the motor control, which you can record by means of the [Oscilloscope](#) for purposes of diagnostics and documentation. ([📄 585](#))

No.	Variable of the motor control	Meaning
(1)	Speed.dnSpeedSetpoint	Speed setpoint
(2)	Current.Current.dnActualMotorCurrent	Actual motor current
(3)	Current.dnActualQuadratureCurrent	Actual Q current
(4)	Speed.dnActualMotorSpeed	Current motor speed
(6)	Frequency.dnActualRotatingFieldFrequency	Current field frequency
(7)	Voltage.dnOutputQuadratureVoltage	Q voltage
(8)	Voltage.dnOutputDirectCurrentCtrl	D voltage
(9)	Voltage.dnActualMotorVoltage	Current motor voltage

**5.8 Parameterisable additional functions**

Detailed information on the parameterisable additional functions can be found in the following subchapters:

Parameterisable additional functions	Available from software version	Motor control*		
		SC	SLVC	VFC plus
<a href="#">Correction of the stator leakage inductance...</a> (📖 204)	V10	●		
<a href="#">Field weakening for synchronous machines</a> (📖 209)	V2.0	●		
<a href="#">Flying restart function</a> (📖 212)	V3.0		●	●
<a href="#">DC-injection braking</a> (📖 215)	V3.0		●	●
* SC = servo control    SLVC = sensorless vector control    VFCplus = V/f control				

### 5.8.1 Correction of the stator leakage inductance...

...and the current controller parameters by means of the saturation characteristic



#### Note!

Function only possible for servo control!

The current controller must be adjusted to the electrical characteristics of the motor stator resistance ([C00084](#)) and stator leakage inductance ([C00085](#)). In case of modern motors, the stator leakage inductance changes with the height of the current so that a new current controller setting is required for each current height.

When the motor is operated with very low and very high currents (e.g. in *Pick and place* applications), it is not always possible to achieve a satisfactory current controller setting for all operating points. For this purpose, the correction of the stator leakage inductance and current controller parameters is now possible via an adjustable saturation characteristic that can be set in [C02853](#) (17 interpolation points).

The following picture shows a typical saturation characteristic of an MCS motor:

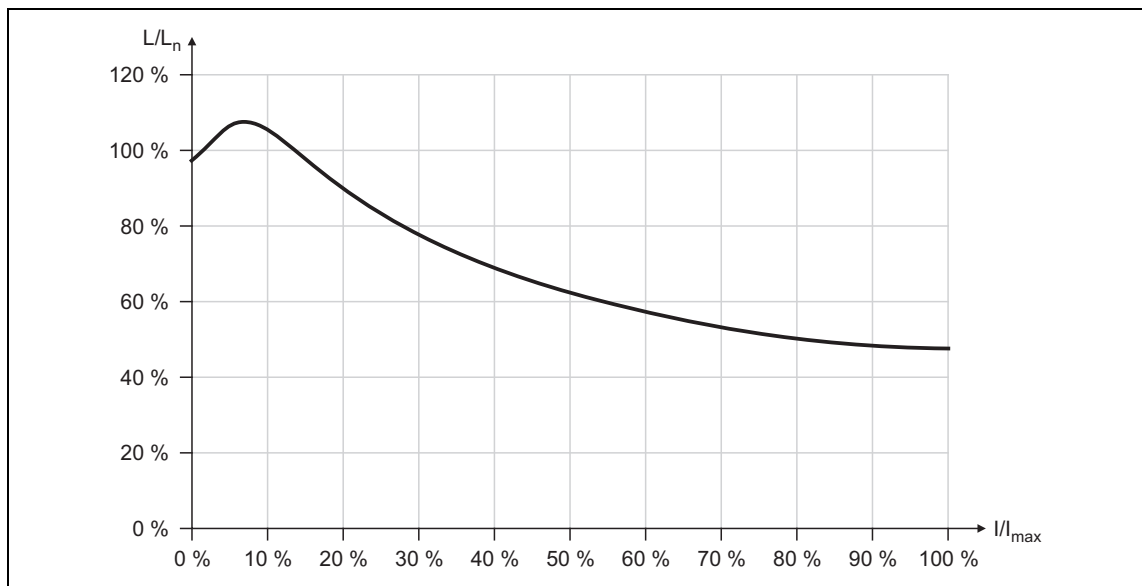

[5-22] Saturation characteristic: Inductance referring to the inductance for rated current

- By optimising the current controller with different current setpoints such a characteristic can be determined "by trial" and set in [C02853](#).
- The correction by means of this saturation characteristic can be switched on/off via [C02859](#).



#### Note!

The saturation characteristic is not only used for the correction of the current controller but also influences the current controller feedforward control ([C00074](#)).

### Distribution of the grid points

- The saturation characteristic is defined by 17 interpolation points which are distributed linearly on the x axis.
- Interpolation point 17 represents 100 % of the maximum motor current in the process ([C02855](#)).

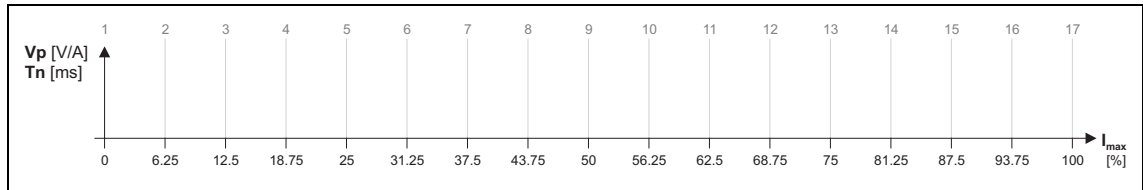

[5-23] Saturation characteristic: Distribution of the grid points

### Example for determining the saturation characteristic

#### Given values:

- Rated motor current: 5 A
- Maximum motor current: 20 A
- Maximum process current: 15 A (must be set later in [C00022](#))

#### Procedure:

1. Deactivate correction ([C02859](#) = "OFF").
2. Set the maximum current up to which the motor is to be operated in the process in [C02855](#) (in this example "15 A").
  - The value set in [C02855](#) has to be greater or the same as [C00022](#).
3. Adjust the current controller with different current setpoints and take down the corresponding settings for Vp and Tn.
  - The procedure for the adjustment is described in the chapter "[Optimise current controller](#)".
  - The current setpoints that are to be set for the respective adjustment in [C00022](#) result from the scaling of the maximum process current to the x axis of the saturation characteristic.
  - The grid points which are required to define the saturation characteristic with a sufficient quality varies from motor to motor and thus has to be determined individually.

- For this example currents were selected that are part of the interpolation points 5, 9, 13, and 15, and a measurement at rated motor current was carried out:

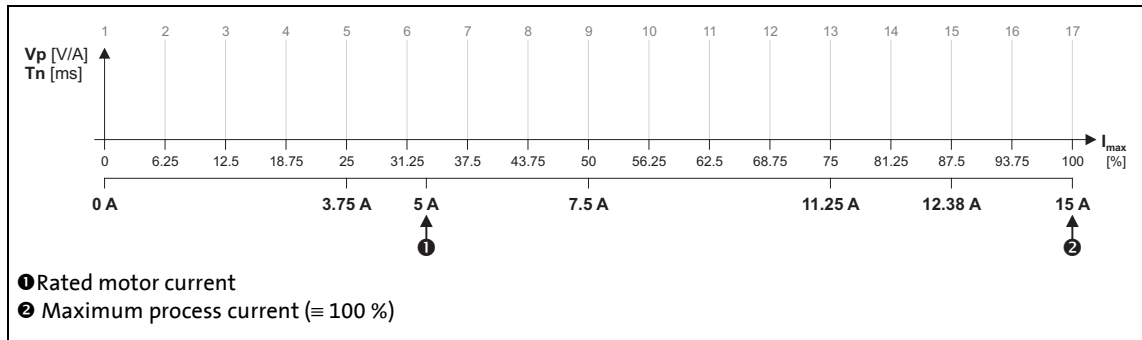

[5-24] Saturation characteristic: Distribution of the grid points

Specifications for adjustment			Measured values	
Grid point	Standardisation	Setting in C00022	Vp [V/A]	Tn [ms]
5	$0.25 \cdot 15 \text{ A} =$	3.75 A	13	6.5
9	$0.5 \cdot 15 \text{ A} =$	7.5 A	8	4
13	$0.75 \cdot 15 \text{ A} =$	11.25 A	5	2.5
15	$0.875 \cdot 15 \text{ A} =$	12.38 A	4	2
17	$1.0 \cdot 15 \text{ A} =$	15 A	3	1.7
Rated motor current =		5 A	10	5

#### 4. Create a characteristic based on the values calculated for Vp.

- Here, the values of the grid points which have not been adjusted must be determined by interpolation between two values.
- **Note:** In this example it was assumed that the inductance does not change considerably below 3.75 A. For this reason the same Vp value resulting from a measurement with a motor current of 3.75 A was used for all grid points below 3.75 A.

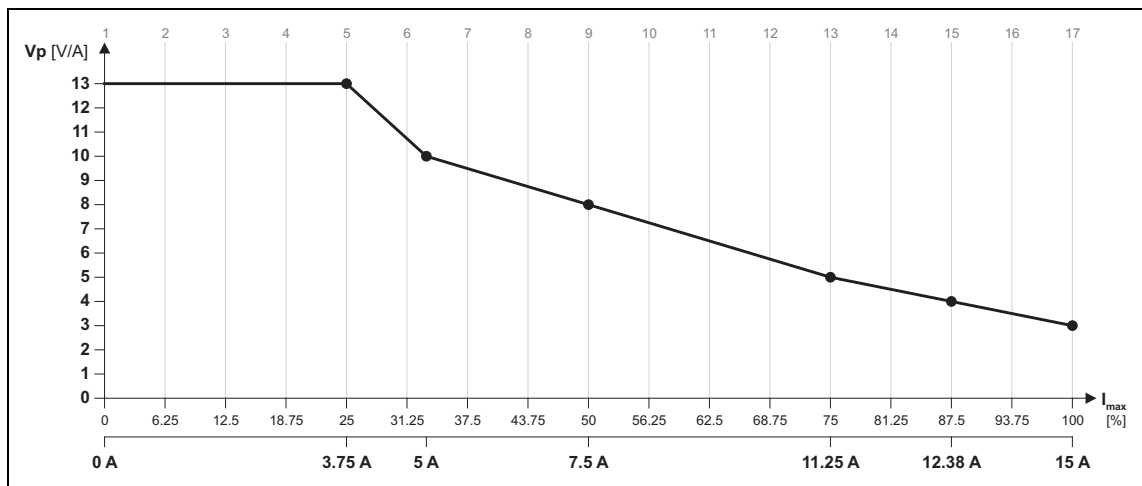

[5-25] Determined saturation characteristic

5. Set the gain  $V_p$  in [C00075](#) and the reset time  $T_n$  in [C00076](#), which have been determined during the adjustment with rated motor current (in this example "5 A"):

- Set [C00075](#) = "10 V/A".
- Set [C00076](#) = "5 ms".

6. Scale the  $V_p$  values on the Y axis of the characteristic to the 100 %  $V_p$  setting in [C00075](#):

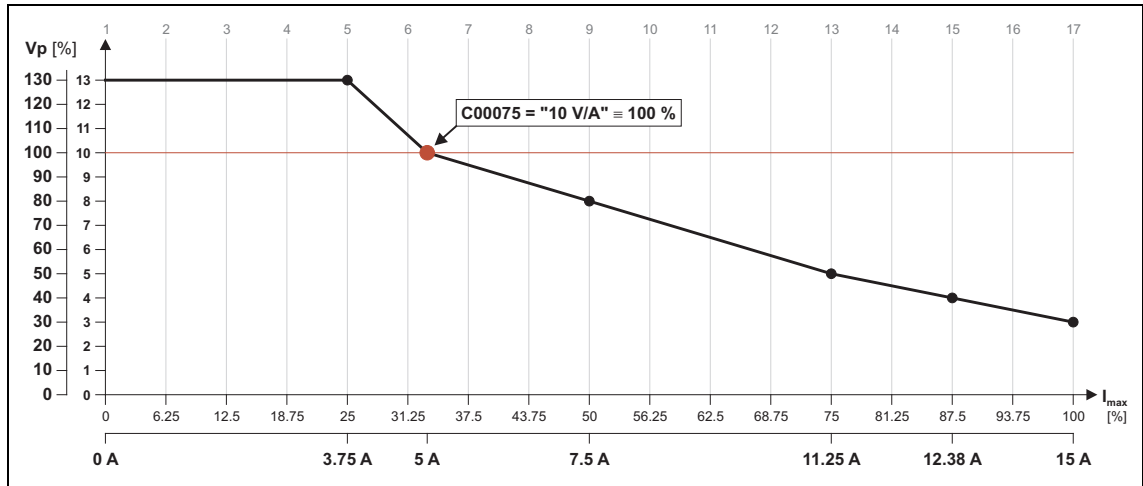

[5-26] Scaling of the determined saturation characteristic to the "100 %" setting in C00075

7. Enter the  $V_p$  values in percent, which are placed on the interpolation point, in [C02853/1...17](#):

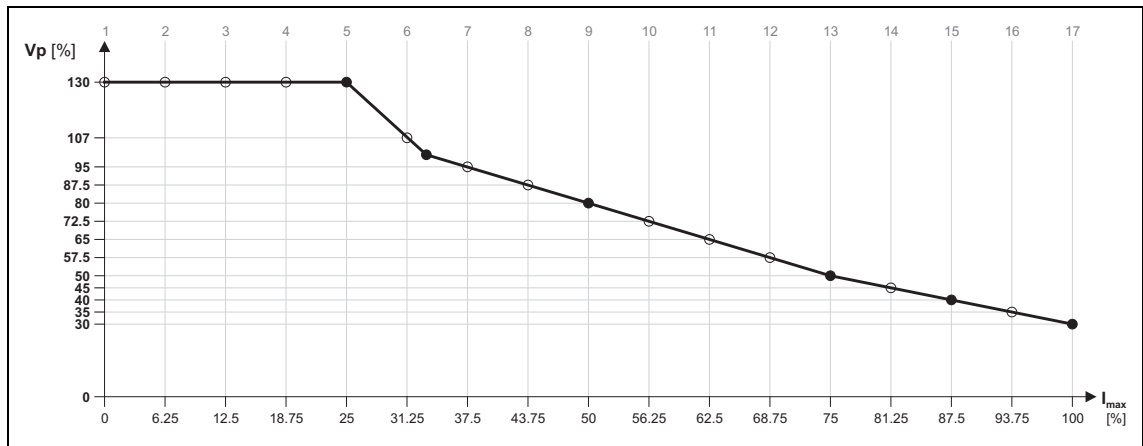

[5-27] Grid point values of the saturation characteristic determined

Grid point	setting	Grid point	setting
1	<a href="#">C02853/1</a> = 130 %	10	<a href="#">C02853/10</a> = 72.5 %
2	<a href="#">C02853/2</a> = 130 %	11	<a href="#">C02853/11</a> = 65 %
3	<a href="#">C02853/3</a> = 130 %	12	<a href="#">C02853/12</a> = 57.5 %
4	<a href="#">C02853/4</a> = 130 %	13	<a href="#">C02853/13</a> = 50 %
5	<a href="#">C02853/5</a> = 130 %	14	<a href="#">C02853/14</a> = 45 %
6	<a href="#">C02853/6</a> = 107 %	15	<a href="#">C02853/15</a> = 40 %
7	<a href="#">C02853/7</a> = 95 %	16	<a href="#">C02853/16</a> = 35 %
8	<a href="#">C02853/8</a> = 87.5 %	17	<a href="#">C02853/17</a> = 30 %
9	<a href="#">C02853/9</a> = 80 %		

8. Enter the maximum process current ("15 A") in [C00022](#).

9. Switch on the correction ([C02859](#) = "ON").
  - When the correction of the stator leakage inductance is switched on, the same current characteristic should occur, irrespective of the current magnitude.
  - Since the current controller gain is corrected actively, the step responses may differ slightly compared to the previous measurements. In this case [C00075](#) and [C00076](#) must be optimised one last time.
10. Save parameter set ([C00002](#) = "11: Save start parameters").



## 5.8.2 Field weakening for synchronous machines

This function is available from software version V2.0!

**Note!**

Function only possible for servo control!

If required, the field weakening mode can be switched on in [C00093](#) for synchronous machines.

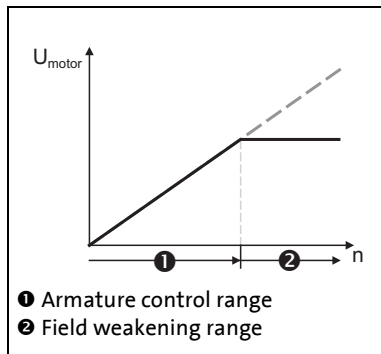

- When field weakening is switched on, the motor magnetising current is increased from 0 A to the maximally effective magnetising current via an internal control loop when the voltage limit is reached.
- As a result, a higher speed can be reached at the same motor voltage or DC-bus voltage.

[5-28] Voltage/speed characteristic with switched-on field weakening

$$n_{\max} = n_{\text{nenn\_mot}} \cdot \frac{800\text{V}}{\sqrt{2} \cdot U_{\text{nenn\_mot}}}$$

[5-29] Calculation of the maximally reachable speed with switched-on field weakening

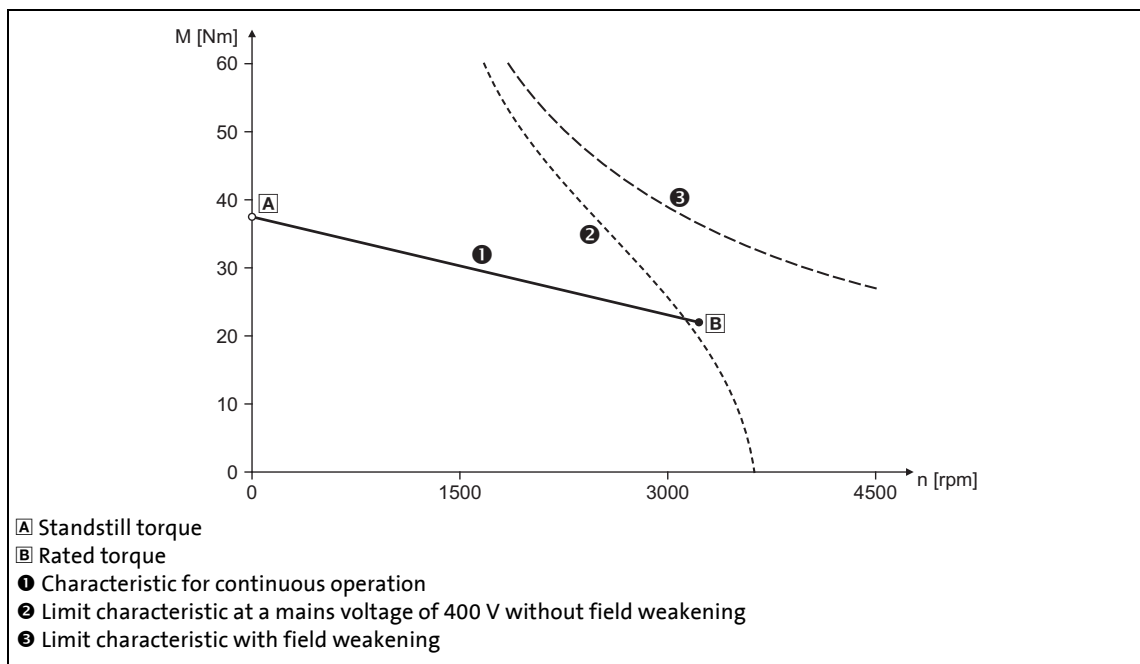

[5-30] Speed/torque characteristics of a synchronous servo motor with field weakening

- 
- The maximally effective motor magnetising current is calculated based on the motor data set in C00084 to C00091. Then the calculated value is internally limited to 98 % of the maximum current set in [C00022](#).
  - When field weakening is switched on, the actually used maximum effective motor magnetising current is shown in [C00092](#), if field weakening is switched off, "0 A" are displayed, as before.

**Note!****If a Lenze motor is used:**

The controller is parameterised automatically so that the field weakening works optimally and there is no danger to the devices.

**Stop!****If an OEM motor is used:**

If pulse inhibit is set in the controller, the DC bus is loaded with the voltage that corresponds to the current speed of the machine.

Since with switched-on field weakening higher speeds can be achieved at a correspondingly higher rotor voltage of the motor, the DC bus can be loaded to a voltage higher than the set DC-bus voltage in case of pulse inhibit and a currently high motor speed and even exceed the maximally permissible voltage of 800 V!

In order to protect the device, either use a brake chopper, or parameterise the speed monitoring via [C00596](#) and [C00607](#), so that only a maximum motor speed is possible that could also be reached with  $V_{dc-bus} = 800 \text{ V}$  without field weakening.

▶ [Maximum motor speed](#) (📖 127)

**Example: Voltage increase in the DC bus when field weakening is switched off**

(For instance by an active setting of the controller inhibit or by tripping a fault or error at high motor speed.)

Field weakening	Speed n	Motor voltage peak value
Switched off	4000 rpm	560 V
	5700 rpm	800 V
	6000 rpm	840 V
Switched on	6000 rpm	560 V

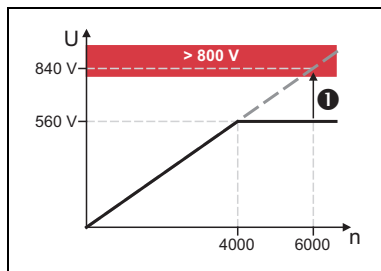

- If pulse inhibit occurs at 6000 rpm and switched-on field weakening, the DC bus is loaded to more than 800 V (❶).
- A speed limitation to 5700 rpm is required since this speed causes a DC-bus voltage of 800 V if field weakening is switched off.

[5-31] Example: Possible DC-bus voltage > 800 V if field weakening gets lost

### 5.8.3 Flying restart function

This function is available from software version V3.0!



#### Note!

Function only possible for V/f control or sensorless vector control!

In the case of V/f control or sensorless vector control, the current motor speed is only provided to the controller if the motor control is active. However, if the controller is enabled, one cannot always assume that the drive is at standstill. The drive for example may still coast down, or be further operated by a load. It cannot always be assumed that fans are at standstill if the controller is enabled, e. g. if the fan impeller is further driven by an air flow in an undefined direction.

If the flying restart mode is activated in [C00990](#), after controller inhibit is deactivated (or DC-injection braking is cancelled), a flying restart process is automatically started to determine the current motor speed if the following conditions are met:

- V/f control or sensorless vector control are selected as motor control in [C00006](#).
- The position control structure is set to "Phase controller is active" in [C02570](#).
- The *MI\_bFlyingSyncBlocked* control input of the motor interface is not assigned or set to FALSE.
- The holding brake, if available, is not applied.



#### Stop!

If the flying restart function is deactivated and the controller is not enabled at standstill, the output voltage and output frequency does not match the current motor speed. High compensation currents may flow!

- The drive is first braked towards 0 Hz and is then accelerated again!
- This may cause the following error messages:
  - Controller: Overload during acceleration phases (fault)
  - Device utilisation  $I_{xt} > C00123$  (warning)
  - Device utilisation  $I_{xt} > 100\%$  (fault)
  - Motor load  $I^2_{xt} > C00127$  (warning)
  - Motor load  $I^2_{xt} > C00120$  (error)
  - Overcurrent detected (fault)
  - Overvoltage in DC bus (trouble)



#### Note!

The flying restart algorithm requires the motor voltage as exact as possible. Therefore it is absolutely necessary to predetermine the inverter error characteristic. ▶ [Optimising the switching performance of the inverter](#) (□ 138)

In addition to the exact motor voltage, the stator resistance must also be known exactly. If the flying restart function should not work as required, slightly adjust the setting of the stator resistance in [C00084](#).

### Procedure

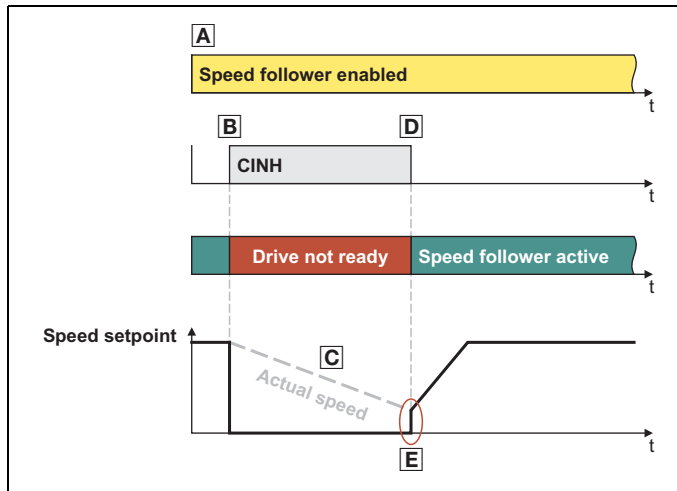

- A. Initial situation: basic function "Speed follower" is enabled and active.
- B. The controller is inhibited while the drive is not at standstill.
- C. The motor coasts down (torqueless).
- D. The controller inhibit is deactivated again.
- E. The flying restart process starts.

[5-32] Process example: Speed follower is active → Controller inhibit → Controller enable

### Flying restart process

The controller calculates the output frequency required for the momentary speed of the coasting motor, then connects to the system, and accelerates the motor to the defined setpoint again.

- The flying restart process serves to prevent the motor from decelerating to zero speed with subsequent acceleration.
- The currently detected flying restart speed is provided to the application via the current motor speed  $MI\_dnActualMotorSpeed\_s$ .

### Parameter setting

- The flying restart algorithm injects a current into the motor to identify the current speed. This flying restart current can be parameterised in [C00991](#) in [%] relating to the rated motor current.
  - The higher the current, the higher the torque acting on the motor.
  - In case of a too low current, a wrong speed can be detected.
- The starting frequency of the flying restart algorithm can be set in [C00992](#).
  - If it is predictable at which frequency the motor can be restarted on the fly, set this frequency here.
- The integration time of the phase controller is set in [C00993](#).
  - The Lenze setting "60 ms" is adapted for machines with a medium power (45 kW).
  - A guide value for the integration time can be calculated with the following equation as a function of the motor power ([C00081](#)):

$$T_i = 1.1 \frac{\mu\text{s}}{\text{W}} \cdot \text{Motor power (C00081)} + 9.4 \text{ ms}$$

- For accelerating the flying restart process, this guide value can be reduced.
- If the flying restart frequency (*Frequency.dnActualRotatingFieldFrequency*) oscillates too much, the integration time has to be increased again.
- A longer integration time increases the time for "catching" the drive.
- To avoid starting a flying restart process at short-time controller inhibit, a time can be set in [C00995](#) for the minimum active controller inhibit time.
  - Since a pulse inhibit > 500 ms causes a controller inhibit, this also applies to the pulse inhibit.

### Short overview: Parameters for flying restart process

Parameters	Info	Lenze setting	
		Value	Unit
<a href="#">C00990</a>	Flying restart: Activation	Off	
<a href="#">C00991</a>	Flying restart: Current	15	%
<a href="#">C00992</a>	Flying restart circuit: start frequency	20.0	Hz
<a href="#">C00993</a>	Flying restart: Integration time	60	ms
<a href="#">C00994</a>	Flying restart: Min. deviation	5.00	°
<a href="#">C00995</a>	Flying restart: Delay time	0	ms

### 5.8.4 DC-injection braking

This function is available from software version V3.0!



#### Note!

Function only possible for V/f control or sensorless vector control!

DC-injection braking can be divided into three functionalities:

#### Manual DC-injection braking

Braking can be activated and deactivated via the internal interface `QSP_bActivateDCBrake` of the basic function "[Quick stop](#)".



#### Tip!

A detailed description of this functionality can be found in the main chapter "Basic drive functions", subchapter "[Quick stop](#)":

▶ [DC-injection braking](#)". (📖 397)

#### DC-injection braking instead of quick stop

If DC-injection braking is activated in [C00976](#) instead of quick stop, DC-injection braking is executed automatically when quick stop is activated.



#### Tip!

A detailed description of this functionality can be found in the main chapter "Basic drive functions", subchapter "[Quick stop](#)":

▶ [DC-injection braking when quick stop is activated](#)". (📖 399)

#### Automatic DC-injection braking

This functionality is part of the basic function "[Brake control](#)".

If mode 22 has been selected for the brake control in [C02580](#), DC-injection braking is executed automatically if the current speed setpoint falls below the speed threshold set in [C02581](#).



#### Tip!

A detailed description of this functionality can be found in the main chapter "Basic drive functions", subchapter "[Brake control](#)":

▶ [Mode 22: Automatic DC-injection braking](#)". (📖 397)

---

**Short overview: Parameters for DC-injection braking**

Parameters	Info	Lenze setting	
		Value	Unit
<a href="#">C00974</a>	DC brakes: Current	0.00	A
<a href="#">C00975</a>	DC brakes Current for quick stop	0.00	A
<a href="#">C00976</a>	DC brake: Activat. by quick stop	Off	



# 5 Motor interface

## 5.9 Monitoring

### 5.9 Monitoring

#### 5.9.1 Signal flow

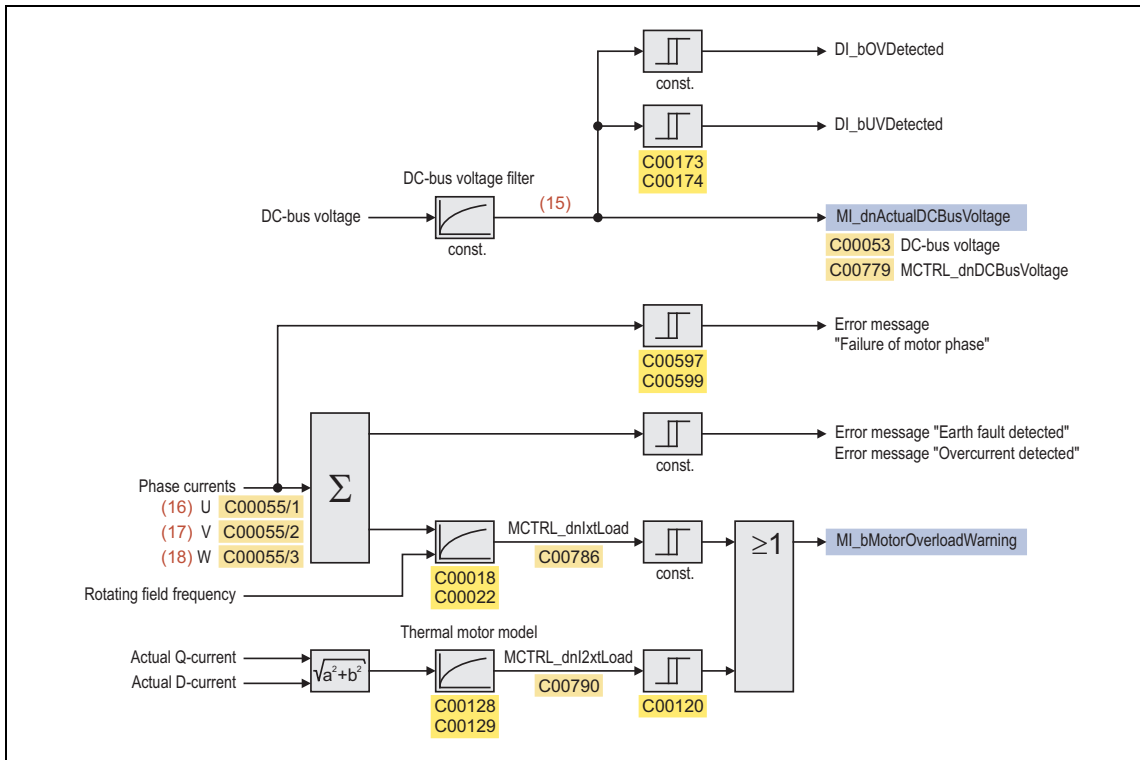

[5-33] Signal flow of motor interface (monitoring)

#### Internal variables of the motor control (oscilloscope signals)

- The red numbers in brackets listed in the signal flow stand for internal variables of the motor control, which you can record by means of the [Oscilloscope](#) for purposes of diagnostics and documentation. ([585](#))

No.	Variable of the motor control	Meaning
(15)	Voltage.dnActualDCBusVoltage	Current DC-bus voltage
(16)	Current.dnActualCurrentPhaseU	Actual motor current (phase U)
(17)	Current.dnActualCurrentPhaseV	Actual motor current (phase V)
(18)	Current.dnActualCurrentPhaseW	Actual motor current (phase W)

### 5.9.2 Motor monitoring (I<sup>2</sup>xt)

The "Servo Drives 9400" are provided with an extended, sensorless thermal I<sup>2</sup>xt motor monitoring function which is based on a mathematical model that calculates a thermal motor utilisation from the detected motor currents.

- The calculation considers the speed dependency of the torque (difference between standstill torque and rated torque).
- [C00066](#) indicates the calculated motor utilisation in [%].
- If the motor utilisation exceeds the advance warning threshold set in [C00127](#), the error message "I2t motor overload OC8" is output and the response (default setting: "Warning") set in [C00606](#) is activated..
- If the switch-off threshold set in [C00120](#) is exceeded, the error message "I2t motor overload OC6" is output and the "Fault" response is activated.
- **From software version V11.0:**  
After mains switching, the thermal model of the I<sup>2</sup>xt motor monitoring is initialised with the starting value initialised in [C01197](#).



#### Stop!

The I<sup>2</sup>xt motor monitoring function is no full motor protection!

Since the motor utilisation calculated in the thermal model gets lost after mains switching, the following operating states cannot be determined correctly:

- Restarting (after mains switching) of a motor that is already very hot.
- Change of the cooling conditions (e.g. cooling air flow interrupted or too warm).

Full motor protection requires additional measures such as the evaluation of temperature sensors that are located directly in the winding or the use of thermal contacts.



#### Note!

The result of the calculated thermal motor utilisation may be too low for quick traversing cycles (so-called pick-and-place applications) which include acceleration and deceleration times of less than 100 ms during overload operation of the motor (often used: linear motor).

### Structure of the I<sup>2</sup>t monitoring

The introduction of a two-component model with two time constants (one for the winding and the other for the housing/laminated core) serves to display the thermal behaviour of the motor up to 500% of the rated current:

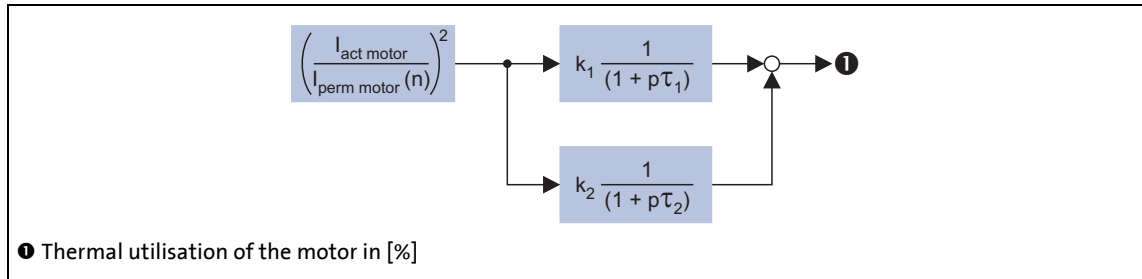

[5-34] Structure of the motor monitoring

Parameters		setting
$I_{\text{act motor}}$	Actual motor current	<a href="#">C00054</a>
$I_{\text{perm motor}}(n)$	Permissible motor current (speed-dependent)	-
$\tau_1$	Therm. time constant coil	<a href="#">C00128/1</a>
$k_1$	Percentage of the winding in the final temperature	<a href="#">C01195</a>
$\tau_2$	Therm. time constant plates	<a href="#">C00128/2</a>
$k_2$	Percentage of the steel plates in the final temperature	100 % - <a href="#">C01195</a>

### Calculation with only one time constant

With [C01195](#) = "0 %" the time constant for the winding is not considered and the thermal model is only calculated with the time constant set for the housing/laminated core.

- The setting [C01195](#) = "0 %" is reasonable if for example the two time constants are not known.
- The calculation simplified due to this setting corresponds to the calculation in the previous Lenze devices (e.g. 9300 servo inverter or ECS).

### Speed-dependent evaluation of the motor current

By selecting a characteristic in [C01196/1...8](#) the permissible motor current is evaluated depending on speed for calculating the thermal motor utilisation.

Parameters	Characteristic	point
<a href="#">C01196/1</a>	$n_1/n_n$	Speed = "0" (standstill)
<a href="#">C01196/2</a>	$I_1/I_n$	Permissible motor current at standstill
<a href="#">C01196/3</a>	$n_2/n_n$	Speed from which the torque must be reduced for self-ventilated motors. • Below this speed the cooling air flow of the integral fan is not sufficient anymore.
<a href="#">C01196/4</a>	$I_2/I_n$	Permissible motor current at speed $n_2$ (torque reduction)
<a href="#">C01196/5</a>	$n_3/n_n$	Rated speed
<a href="#">C01196/6</a>	$I_3/I_n$	Permissible motor current at rated speed
<a href="#">C01196/7</a>	$n_4/n_n$	Speed above the rated speed (in the field weakening range for asynchronous motors)
<a href="#">C01196/8</a>	$I_4/I_n$	Permissible motor current at speed $n_4$ (field weakening)

- The speed-dependent evaluation can be more or less switched off by setting [C01196/1...8](#) to "100 %" each. The calculation simplified due to this setting corresponds to the calculation in previous Lenze devices (e.g. 9300 servo inverter or ECS).



#### Note!

Self-ventilated standard motors are protected insufficiently at low speeds by setting [C01196/1...8](#) to "100 %" each.

Servo motors, however, do not have a point from which the torque must be reduced due to a too low speed.

- When setting the characteristic in [C01196/1...8](#) this point must not be ignored. Hence, point 2 is to be set ideally to point 1 or point 3.

# 5 Motor interface

## 5.9 Monitoring

### 5.9.2.1 Example for entry of the characteristic for asynchronous servo motor

Motor type: MDFMARS 090-32

Data from the catalogue:

- Rated speed  $n_{rated}$ : 1410 rpm → Setting in [C00087](#)
- Rated current I: 6.1 A → Setting in [C00088](#)
- Rated torque  $M_{rated}$ : 10.2 Nm
- Characteristic of maximum torques (50 Hz, star connection):

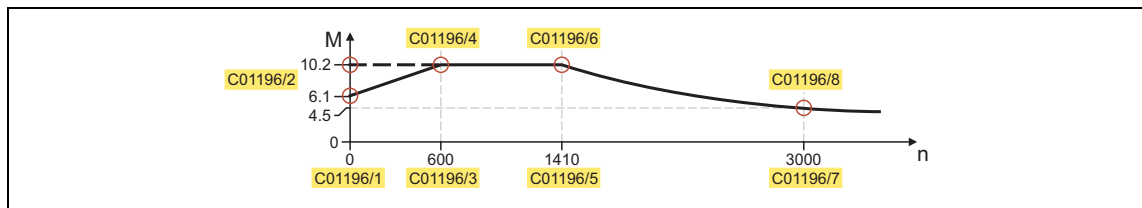

[5-35] Torque/speed characteristic for motor type MDFMARS 090-32 from catalogue



### Note!

At present, relative current values are still expected for the specification of the interpolation points in subcodes 2, 4, 6, 8 of [C01196](#). This example, however, already uses relative torque values, the entry of which shall be possible at a later date.

Parameters	setting	Info
<a href="#">C00128/1</a>	1.0 min	Thermal time constant - winding • Is unknown and is therefore deactivated by setting <a href="#">C01195</a> = "0 %".
<a href="#">C00128/2</a>	5.0 min	Thermal time constant - laminated core/housing
<a href="#">C01195</a>	0 %	Percentage of the winding in the final temperature.
<a href="#">C01196/1</a>	0 %	Speed = "0" (standstill)
<a href="#">C01196/2</a>	Permissible motor torque at standstill	
Self-ventilated:	60 %	= 6.1 Nm / 10.2 Nm * 100 %
Forced-ventilated:	100 %	= 10.2 Nm / 10.2 Nm * 100 %
<a href="#">C01196/3</a>	Speed $n_2$ from which the torque must be reduced for self-ventilated motors.	
Self-ventilated:	43 %	= 600 rpm / 1410 rpm * 100 %
Forced-ventilated:	0 %	No torque reduction required.
<a href="#">C01196/4</a>	100 %	Permissible motor torque at speed $n_2$ (torque reduction)
<a href="#">C01196/5</a>	100 %	Rated speed ( $\equiv$ 1410 rpm)
<a href="#">C01196/6</a>	100 %	Permissible motor torque at rated speed ( $\equiv$ 10.2 Nm)
<a href="#">C01196/7</a>	213 %	Speed above the rated speed (in the field weakening range for asynchronous motors) = 3000 rpm / 1410 rpm * 100 %
<a href="#">C01196/8</a>	44 %	Permissible motor torque at speed $n_4$ (field weakening) = 4.5 Nm / 10.2 Nm * 100 %

# 5 Motor interface

## 5.9 Monitoring

### 5.9.2.2 Example for entry of the characteristic for synchronous servo motor

Motor type: MCS 06C60

#### Data from the catalogue:

- Rated speed  $n_{\text{rated}}$ : 6000 rpm → Setting in [C00087](#)
- Rated current I: 2.4 A → Setting in [C00088](#)
- Rated torque  $M_N$ : 0.5 Nm (in S1 operation: 0.55 Nm)
- Characteristic - maximum torques:

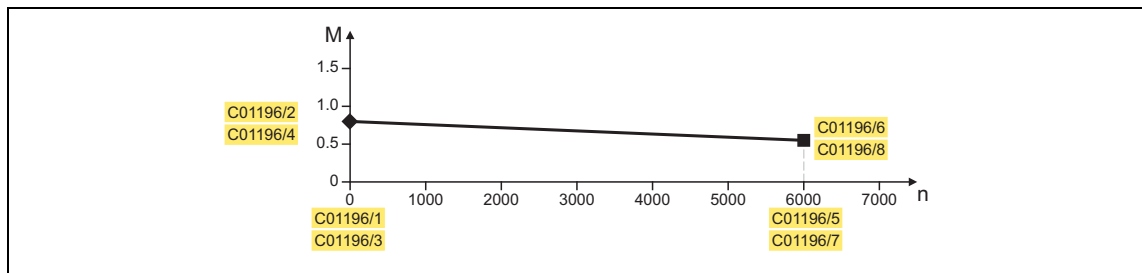

[5-36] Torque/speed characteristic for motor type MCS 06C60 from the catalogue



#### Note!

At present, relative current values are still expected for the specification of the interpolation points in subcodes 2, 4, 6, 8 of [C01196](#). This example, however, already uses relative torque values, the entry of which shall be possible at a later date.

Parameters	setting	Info
<a href="#">C00128/1</a>	1.0 min	Thermal time constant - winding
<a href="#">C00128/2</a>	14.2 min	Thermal time constant - laminated core/housing
<a href="#">C01195</a>	27 %	Percentage of the winding in the final temperature. (Only the laminated core percentage is known.)
<a href="#">C01196/1</a>	0 %	Speed = "0" (standstill)
<a href="#">C01196/2</a>	160 %	Permissible motor torque at standstill = 0.8 Nm / 0.5 Nm * 100 %
<a href="#">C01196/3</a>	0 %	Speed $n_2$ from which the torque must be reduced for self-ventilated motors.
<a href="#">C01196/4</a>	160 %	Permissible motor torque at speed $n_2$ (torque reduction)
<a href="#">C01196/5</a>	100 %	Rated speed ( $\equiv$ 6000 rpm)
<a href="#">C01196/6</a>	100 %	Permissible motor torque at rated speed ( $\equiv$ 0.5 Nm)
<a href="#">C01196/7</a>	100 %	Speed above rated speed
<a href="#">C01196/8</a>	100 %	Permissible motor torque at speed $n_4$ (field weakening)

### 5.9.2.3 UL 508-compliant I<sup>2</sup>x motor temperature monitoring

The following test steps 1 ... 3 are part of the UL 508C-compliant device acceptance. They have to be executed successfully during the I<sup>2</sup>x motor monitoring.

#### Test step 1

- Motor overload:  $6 \times I_{\text{rated,mot}}$  ( $I_{\text{rated,mot}}$ : Rated motor current ([C00088](#)))
- Trigger time: Max. 20 s after the overload has occurred

Code	setting	Info
<a href="#">C00128/2</a>	≤ 11.8 min	Thermal time constant - laminated core/housing
<a href="#">C01195</a>	0 %	Percentage of the winding in the final temperature
<a href="#">C00120</a>	100 %	Switch-off threshold of motor overload protection (I <sup>2</sup> x)

#### Test step 2

- Motor overload:  $1,1 \times I_{\text{rated,mot}}$  ( $I_{\text{rated,mot}}$ : Rated motor current ([C00088](#)))
- In case of a motor field frequency of 10 Hz, the I<sup>2</sup>x motor monitoring has to be tripped faster than with a motor field frequency of 20 Hz.

Code	setting	Info
<a href="#">C01196/1</a>	0 %	Speed = 0 (standstill)
<a href="#">C01196/2</a>	< 100 %	Permissible motor torque at standstill
<a href="#">C01196/3</a>	$(20 \text{ Hz} / \text{C00089}) * 100 \%$	Speed $n_2$ from which on the torque must be reduced
<a href="#">C01196/4</a>	100 %	Permissible motor torque at speed $n_2$ (torque reduction)

#### Test step 3

- After mains switching and a motor load > 100 % of the (motor current ([C00054](#)) > rated motor current ([C00088](#)), I<sup>2</sup>x motor monitoring must be tripped faster than before mains switching with the same overload.
- From software version V11.0:  
Initial value of the thermal model of the I<sup>2</sup>x motor monitoring: [C01197](#) > 0 %.

**Example** for a UL 508C-compliant total parameterisation of the I<sup>2</sup>xT motor monitoring of the device:

Code	setting	Info
<a href="#">C00120</a>	100 %	Switch-off threshold of motor overload protection (I <sup>2</sup> xT)
<a href="#">C00128/2</a>	≤ 11.8 min	Thermal time constant - laminated core/housing
<a href="#">C01195</a>	0 %	Percentage of the winding in the final temperature
<a href="#">C01196/1</a>	0 %	Speed = 0 (standstill)
<a href="#">C01196/2</a>	< 100 %	Permissible motor torque at standstill
<a href="#">C01196/3</a>	(20 Hz / <a href="#">C00089</a> ) * 100 %	Speed n <sub>2</sub> from which on the torque must be reduced
<a href="#">C01196/4</a>	100 %	Permissible motor torque at speed n <sub>2</sub> (torque reduction)
<a href="#">C01196/5</a>	100 %	Rated speed
<a href="#">C01196/6</a>	100 %	Permissible motor torque at rated speed
<a href="#">C01196/7</a>	100 %	Rated speed
<a href="#">C01196/8</a>	100 %	Speed above rated speed
<a href="#">C01197</a>	> 0 %	Initial value of the thermal model of the I <sup>2</sup> xT motor monitoring



### 5.9.3 Motor temperature monitoring

If the winding temperature detected by the motor temperature sensor exceeds the limit value set in [C00121](#), the response set in [C00584](#) is activated as advance warning.

- In the Lenze setting the "Warning" response occurs if the winding temperature exceeds 120 °C.
- As soon as the fixed limit value of 150 °C is exceeded, the response set in [C00583](#) is activated (default setting: "Fault").
- If an open circuit is detected in the motor temperature sensor, the response set in [C00594](#) (default setting: "Fault") is activated.



#### Note!

By setting [C00583](#) = "0" the monitoring response and the temperature correction is switched off within the motor control (identification and parameter correction)

This setting for example is reasonable if no usable winding temperature signal is available.



#### Tip!

The winding temperature currently detected by the motor temperature sensor is displayed in [C00063](#).

### 5.9.3.1 Specific characteristic for the motor temperature sensor

If required, you can define and activate a special characteristic for the motor temperature sensor.

- The specific characteristic is defined on the basis of two grid points which must be set in [C01191](#) and [C01192](#). Those two points define a line which is extrapolated to the right and to the left.
- The special characteristic is activated by setting [C01190](#) = "1".
- In the Lenze setting, the specific characteristic is defined as follows:

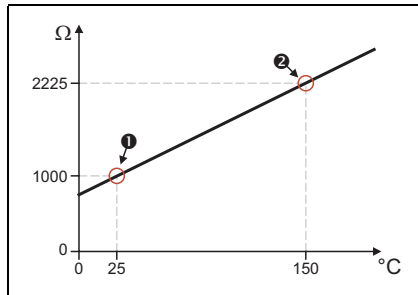

[5-37] Lenze setting of the special characteristic

- Interpolation point ❶
  - [C01191/1](#) = 25 °C
  - [C01192/1](#) = 1000 Ω
- Interpolation point ❷
  - [C01191/2](#) = 150 °C
  - [C01192/2](#) = 2225 Ω



#### Note!

- If a motor is selected from the motor catalogue, parameters [C01190](#), [C01191](#), and [C01192](#) are overwritten!
- If the controller measures a resistance below 122 Ω, this is interpreted as a sensor error and a temperature of 255 °C is output.

The following applies from software version V4.0:

- Sometimes a short circuit is a desired state (e.g. temperature contact closed below 140 °C). For this purpose, the interpolation point 1 ([C01191/1](#)) must be below 122 Ω to prevent the triggering of sensor errors. In this case the temperature continues to be calculated.

### 5.9.3.2 Motor temperature monitoring (PTC)

For detecting and monitoring of the motor temperature, a PTC thermistor (DIN 44081/DIN 44082) or a thermal contact (NC contact) can be connected to the terminals X106/T1 and X106/T2.



#### Stop!

- This monitoring is only active if the controller is supplied via the line side, i.e. if the DC-bus voltage ( $U_z$ ) > undervoltage threshold (LU).
- The controller can only evaluate one PTC thermistor!  
Do not connect several PTC thermistors in series or parallel.
- If several motors are operated on one controller, use thermal contacts (NC contacts) connected in series.
- To achieve full motor protection, an additional temperature monitoring with separate evaluation must be installed.



#### Note!

- In the Lenze setting ([C00585](#) = "0: No response"), motor temperature monitoring is deactivated!
- Lenze three-phase AC motors are provided with a thermal contact on delivery.

- The monitoring responds from a resistance value of 1.6 k $\Omega$  at connections X106/T1 and X106/T2, see functional test below.
- If the monitoring responds:
  - The error response set in [C00585](#) is activated (Lenze setting: "No response").
  - the error message "PTC has triggered" (0x0077000f) is entered into the logbook of the controller.
  - the status output *MI\_bMotorOverloadWarning* is set to TRUE.



#### Tip!

We recommend to always activate the PTC input when using motors which are equipped with PTC thermistors or thermostats. This prevents the motor from being destroyed by overheating.

#### Functional test

Connect a fixed resistor to the PTC input:

- $R > 4 \text{ k}\Omega$  : Fault message must be activated.
- $R < 1 \text{ k}\Omega$  : Fault message must not be activated.

---

### 5.9.3.3 Temperature monitoring of a second motor

[This function is available from software version V7.0!](#)

---

From software version V7.0 onwards, two motor temperature sensors can be evaluated simultaneously via the two encoder inputs X7 and X8 when two motor are used (e.g. double motor for a storage and retrieval unit). For this purpose, the selection "X7 and X8 in parallel" must be set as feedback system for the motor temperature in [C01193](#).

- In this case, always the higher temperature of the two detected temperatures is displayed as the current motor temperature on the **Diagnostics** tab and in [C00063](#).
- Moreover, the following display parameters are available from software version V6.0 onwards:
  - [C01200/1](#): Motor temperature via X7
  - [C01200/2](#): Motor temperature via X8
- If one of the two detected temperatures exceeds the limit value set in [C00121](#), the response set in [C00584](#) is activated as advance warning.
  - In the Lenze setting the "Warning" response occurs if one of the two winding temperature exceeds 120 °C.
- As soon as one of the two detected temperatures exceeds the fixed limit value of 150 °C, the response set in [C00583](#) is activated (default setting: "Fault").
- If an open circuit is detected in one of the two motor temperature sensors, the response set in [C00594](#) (default setting: "Fault") is activated.
- It is not possible to set different responses for the two temperature monitoring modes.
- For the motor model in the controller, the mean value of both detected temperatures is used.

#### Related topics:

- ▶ [Brake control](#) ▶ [Control of two motor holding brakes](#) (📖 556)

## 5.9.4 Motor phase failure monitoring

### 5.9.4.1 Monitoring of the individual motor phases during operation

#### Failure of one motor phase during operation

If a current-carrying motor phase (U, V, W) fails during operation, the response set in [C00597](#) is executed (Lenze setting: "No response") if two conditions are fulfilled:

- Condition 1: Monitoring is activated

To safely detect a motor phase failure, a certain motor current must flow for the current sensor system.

- Monitoring will therefore only be activated if, in the case of servo control the setpoint of the motor current, and in the case of sensorless vector control or V/f control the actual value motor current (display in [C00054](#)) has exceeded a certain current value.
- The current value for the activation can be set in [C00599](#) in [%] with regard to the maximum device current (display in [C00789](#)).
- Condition 2: A specific commutation angle was covered without the detection of a current flow.

In this case monitoring works according to the principle of checking for each motor phase that a current flows depending on the commutation angle.

- Monitoring responds if a rotating field is output and hence a specific commutation angle (approx. 150°, electric) is covered without the current having exceeded a (non-parameterisable) threshold that depends on the device power.



#### Note!

- In case of sensorless vector control or V/f control, the safe detection of a motor phase failure is only carried out if the actual current has exceeded the 3.5-fold value of the threshold parameterised in [C00599](#).
- The dependence on the commutation angle also causes a dependence on the motor type used:
  - The commutation angle and the angle at the shaft (number of pole pairs) of a synchronous machine are proportional. This makes it possible to predict which shaft angle is maximally covered in case of error.
  - An asynchronous machine has an additional slip between the commutation angle and the angle on the shaft. This results in a load dependency due to which it is impossible to predict the maximally covered shaft angle in the event of a fault. In certain applications (e.g. hoists during lowering operation at non-zero speeds) it may be possible that a rotating field is no longer applied. Instead, a DC current flows. In this case, condition 2 is no longer met.

---

### Failure of multiple motor phases during operation

This function is available from software version V10.0!

---

The following operating modes enable the detection of multiple motor phases during operation:

- VFCplus: V/f control closed loop
- SLVC: sensorless vector control

The monitoring for failure of multiple motor phases is *active* if

1. [C00597](#) is set to a response other than "No response" (Lenze setting) and
2. the motor voltage exceeds the threshold value parameterised in [C02867](#).

The "Motor disconnected" fault message is issued if the motor current is lower than the device-dependent threshold value for > 20 ms.

The monitoring for failure of multiple motor phases can be *deactivated* if a value of 1000.0 V is parameterised in [C02867](#).

### 5.9.4.2 Checking the individual motor phases before operation is started

This function is available from software version V5.0!

From software version V5.0 a check via test signal application has been added. It injects a current into the machine before the actual operation is started, by means of which both a motor phase failure and the existence of the motor are checked. Only after the check has been carried out successfully, the actual operation is continued.

- The setpoint current amplitude corresponds to the lower of the two following values:

$$50\% \cdot \sqrt{2} \cdot \text{Rated device current}$$

or

$$50\% \cdot \sqrt{2} \cdot \text{Rated motor current}$$

- The test signal application is activated directly after controller enable if the following conditions are fulfilled:
  - In [C00597](#) a response other than "No response" is set.
  - No test mode is activated ([C00398](#) = 0).
  - No identification procedure is active (by device command [C00002](#) = "51", "52", "71" or "72").
- The check actuates the response set in [C00597](#) if one or more motor phase currents have not reached a certain threshold value within 5 ms after controller enable.
  - The threshold value depends on the device power and cannot be parameterised.
  - If only one motor phase current does not reach the threshold value, "Motor phase U/V/W not available" is entered in the logbook.
  - If several motor phases do not reach the threshold value, the motor is considered as not connected, and "Motor not connected" is entered in the logbook.
- The check is completed successfully if all three motor phase currents have exceeded the threshold value. Then the actual operation is continued immediately.



#### Note!

- As the check is cancelled immediately if all three motor phase currents have exceeded the threshold value, the setpoint current usually is not achieved.
- In order to be able to achieve the threshold value used for the check, the rated motor current must at least be 10 % of the maximum device current (display in [C00789](#)).
- This monitoring is independent of the further rotation of the commutation angle.

### 5.9.4.3 Limits of motor phase failure monitoring

Motor phase failure monitoring can be activated for both synchronous and asynchronous motors. However, it is possible that a current flow cannot be detected for sure in the case of certain operating statuses of correctly connected synchronous motors. Hence, a fault is triggered.

The following table provides an overview:

Operating status		Synchronous motor	Asynchronous motor
Check of the motor phases <u>prior to operation</u>		ž	ž
Check of the motor phases <u>during operation</u>			
• $I_q < C00599$	at standstill	<input type="checkbox"/>	<input checked="" type="checkbox"/>
	when motor is rotating	<input type="checkbox"/>	<input checked="" type="checkbox"/>
• $I_q \geq C00599$	at standstill	<input type="checkbox"/>	<input checked="" type="checkbox"/>
	when motor is rotating	<input checked="" type="checkbox"/>	<input checked="" type="checkbox"/>

Explanation	
<input checked="" type="checkbox"/>	Phase failure is detected for sure.
<input type="checkbox"/>	Phase failure detection may trip without a fault pending.
$I_q$	Torque-forming current component

#### Special case: Hoist

The special case "Hoist" is already referred to in the chapter

▶ [Monitoring of the individual motor phases during operation](#) (📖 229)

Motor phase failure monitoring may trigger a fault message in a hoist if the applied asynchronous motor reaches the following working point:

- The hoist moves downwards, i.e. the motor is in generator mode.
- The slip frequency equals the field frequency in terms of amount. Both frequencies mutually neutralise themselves due to their opposite effective directions.



---

### 5.9.5 Maximum current monitoring

The ultimate motor current  $I_{ULT}$  to be parameterised in [C00620](#) is a limit value to protect the motor from destruction or influence of the rated data.

- This limit value must not be travelled cyclically in the drive process.
- The maximum current parameterisable in [C00022](#) should have a sufficient distance from this limit value.
- If the instantaneous value of the motor current exceeds the limit value set in [C00620](#) the response set in [C00619](#) is executed for motor protection (Lenze setting: Fault).



#### Note!

When you select a Lenze motor from the catalogue and transfer the plant parameters of the motor to the controller, the setting in [C00620](#) is automatically adjusted to the selected motor.

# 5 Motor interface

## 5.10 Internal interfaces | "LS\_MotorInterface" system block

### 5.10 Internal interfaces | "LS\_MotorInterface" system block

The **LS\_MotorInterface** system block provides the internal interfaces to the driving machine, consisting of the phase controller, speed controller, and motor control in the function block editor.

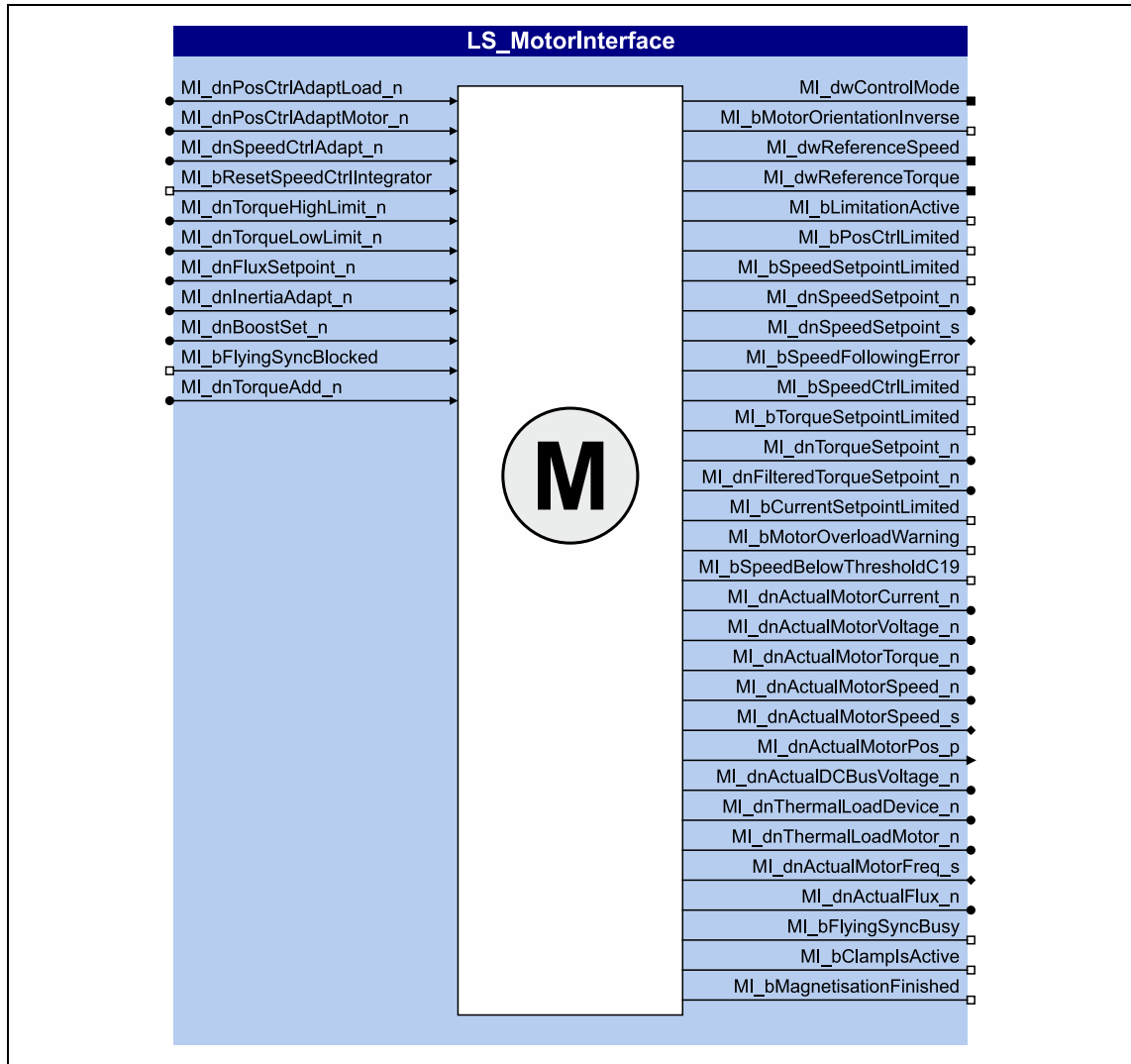

#### Note!

All input and output signals of the motor interface directly refer to the motor!

## Inputs

Identifier DIS code   data type	Information/possible settings				
MI_dnPosCtrlAdaptLoad_n <a href="#">C02568/1</a>   DINT	Dynamic change of the proportional gain $V_p$ of the position controller during operation <ul style="list-style-type: none"> <li>For software versions lower than V5.0 the following applies: Internal limitation to 10 ... 200 %</li> <li>From software version V5.0 the following applies: Internal limitation to 0 ... 200 %</li> </ul>				
MI_dnPosCtrlAdaptMotor_n <a href="#">C02568/2</a>   DINT	Dynamic change of the proportional gain $V_p$ of the phase controller during operation <ul style="list-style-type: none"> <li>For software versions lower than V5.0 the following applies: Internal limitation to 10 ... 200 %</li> <li>From software version V5.0 the following applies: Internal limitation to 0 ... 200 %</li> </ul>				
MI_dnSpeedCtrlAdapt_n <a href="#">C02568/3</a>   DINT	Dynamic change of the proportional gain $V_p$ of the speed controller during operation <ul style="list-style-type: none"> <li>If the input is assigned, the following applies: <math>V_p = MI\_dnSpeedCtrlAdapt\_n [\%] * C00070</math></li> <li>If the input is not assigned, the following applies: <math>V_p = 100 \% * C00070 = C00070</math></li> <li>Internal limitation to 10 ... 200 %</li> <li>► <a href="#">Optimising the speed controller</a> (150)</li> </ul>				
MI_bResetSpeedCtrlIntegrator <a href="#">C02569/2</a>   BOOL	Reset integral action component in the speed controller <table border="1"> <tr> <td>TRUE</td> <td>Integral action component is reset to "0".</td> </tr> </table>	TRUE	Integral action component is reset to "0".		
TRUE	Integral action component is reset to "0".				
MI_dnTorqueHighLimit_n <a href="#">C02568/4</a>   DINT MI_dnTorqueLowLimit_n <a href="#">C02568/5</a>   DINT	Upper/lower limit value for correcting variable of the speed controller and total torque setpoint <ul style="list-style-type: none"> <li>These two inputs serve to select an external torque limitation.</li> <li>If the motor torque reaches the selected limits, the drive can no longer follow the speed setpoint!</li> <li>If the torque limitation is active, the output <i>MI_bTorqueSetpointLimited</i> is set to TRUE.</li> <li>100 % <math>\equiv</math> <a href="#">C00057/2</a></li> <li>Only a positive torque is permissible as upper limit value.</li> <li>Only a negative torque is permissible as lower limit value.</li> <li>The motor mounting position (<a href="#">C02527</a>) defines the assignment to the limitation inputs of the motor control.</li> <li>The internally effective torque limit values are displayed in <a href="#">C02559/1...2</a>.</li> </ul>				
MI_dnFluxSetpoint_n <a href="#">C02568/7</a>   DINT	Setpoint for the field controller				
MI_dnInertiaAdapt_n <a href="#">C02568/8</a>   DINT	Adaptation of the moment of inertia in [%] <ul style="list-style-type: none"> <li>If input is not assigned = 100 %</li> <li>Internal limitation to 0 ... 200 %</li> </ul>				
MI_dnBoostSet_n <a href="#">C02568/9</a>   DINT From V3.0	Boost voltage <ul style="list-style-type: none"> <li>100 % <math>\equiv</math> 1000 V</li> </ul>				
MI_bFlyingSyncBlocked <a href="#">C02569/16</a>   BOOL From V3.0	Block flying restart <ul style="list-style-type: none"> <li>► <a href="#">Flying restart function</a> (212)</li> </ul> <table border="1"> <tr> <td>FALSE</td> <td>Flying restart function is active</td> </tr> <tr> <td>TRUE</td> <td>Flying restart process is blocked.</td> </tr> </table>	FALSE	Flying restart function is active	TRUE	Flying restart process is blocked.
FALSE	Flying restart function is active				
TRUE	Flying restart process is blocked.				

Identifier DIS code   data type	Information/possible settings
MI_dnTorqueAdd_n <a href="#">C02568/10</a>   DINT From V8.0	<p>Additional torque feedforward control value in [%]</p> <p>This input serves to provide an additional torque setpoint. In this way, you can provide an additional torque for the basic functions manual jog, positioning and homing besides the acceleration feedforward control.</p> <ul style="list-style-type: none"> <li>• 100 % = motor reference torque</li> </ul> <p>If the controller is enabled, the torque setpoints at this input have a direct effect on the drive!</p> <p>The user has to</p> <ul style="list-style-type: none"> <li>• apply the appropriate setpoint for every state of the drive.</li> <li>• avoid setpoint step-changes.</li> </ul>
	- 200 %
	+ 200 %

### Outputs

Identifier DIS code   data type	Value/meaning
MI_dwControlMode DWORD	<p>Active control structure of the motor control</p> <ul style="list-style-type: none"> <li>• Displayed value is bit-coded:</li> </ul>
	Bit 0 Encoderless motor control
	Bit 1 Position control (Setpoint from setpoint position)
	Bit 2 Position control (Setpoint from integrated setpoint speed)
	Bit 3 closed-loop speed control
	Bit 4 Closed-loop torque control
MI_bMotorOrientationInverse BOOL	<p>Parameterised motor mounting position</p>
	FALSE Motor mounting position in the same direction, setpoints are not defined.
	TRUE Motor mounting position in the opposite direction, setpoints are reversed.
MI_dwReferenceSpeed DWORD	Parameterised motor reference speed ( <a href="#">C00011</a> ) in [rpm]
MI_dwReferenceTorque DWORD	<p>Reachable motor torque with <math>I_{\max\_device}</math> (<a href="#">C00022</a>) in [mNm]</p> <ul style="list-style-type: none"> <li>• 1000 mNm <math>\equiv</math> 1 Nm</li> <li>• Display in <a href="#">C00057/2</a> in [Nm]</li> </ul>
MI_bLimitationActive <a href="#">C02569/3</a>   BOOL	<p>Status signal "Internal limitation active"</p> <ul style="list-style-type: none"> <li>• Group signal for all limitation messages.</li> </ul>
	TRUE One of the internal limitations is active.
MI_bPosCtrlLimited <a href="#">C02569/4</a>   BOOL	<p>Status signal "Phase/position controller at the limit"</p>
	TRUE The limitation of the phase and/or position controller is active.
MI_bSpeedSetPointLimited <a href="#">C02569/5</a>   BOOL	<p>Status signal "Resulting speed setpoint at the limit"</p>
	TRUE The resulting speed setpoint is limited to the limit values parameterised in <a href="#">C00909/1</a> and <a href="#">C00909/2</a> .
MI_dnSpeedSetpoint_n DINT	<p>Current speed setpoint from position control and speed feedforward control or direct setpoint selection in [%]</p> <ul style="list-style-type: none"> <li>• After limitation by the upper speed limit value (<a href="#">C00909/1</a>) and lower speed limit value (<a href="#">C00909/2</a>).</li> <li>• 100 % <math>\equiv</math> Motor reference speed (<a href="#">C00011</a>)</li> </ul>
MI_dnSpeedSetpoint_s DINT	<p>Current speed setpoint from position control and speed feedforward control or direct setpoint selection in [rpm]</p> <ul style="list-style-type: none"> <li>• After limitation by the upper speed limit value (<a href="#">C00909/1</a>) and lower speed limit value (<a href="#">C00909/2</a>).</li> </ul>

Identifier DIS code   data type	Value/meaning
MI_bSpeedFollowingError <a href="#">C02569/10</a>   BOOL	Status signal "Impermissible speed control deviation"
	TRUE   Speed control deviation is higher than the window set in <a href="#">C00576</a> .
MI_bSpeedCtrlLimited <a href="#">C02569/6</a>   BOOL	Status signal "Speed controller at the limit"
	TRUE   The speed controller limitation is active.
MI_bTorqueSetpointLimited <a href="#">C02569/7</a>   BOOL	Status signal "Total torque setpoint at the limit"
	TRUE   The total torque setpoint is limited.
MI_dnTorqueSetpoint_n DINT	Current torque setpoint from speed control and torque feedforward control or direct setpoint selection <ul style="list-style-type: none"> <li>• After limitation by <i>MI_dnTorqueLimit_n</i>.</li> <li>• 100 % = <a href="#">C00057/2</a></li> </ul>
MI_dnFilteredTorqueSetpoint_n DINT	Filtered torque setpoint (after jerk limitation and band-stop filters) <ul style="list-style-type: none"> <li>• 100 % = <a href="#">C00057/2</a></li> </ul>
MI_bCurrentSetpointLimited <a href="#">C02569/8</a>   BOOL	Status signal "Setpoint for current controller at the limit"
	TRUE   The setpoint for the current controller is limited to $I_{\max\_device}$ ( <a href="#">C00022</a> ).
MI_bMotorOverloadWarning <a href="#">C02569/11</a>   BOOL	Status signal "Motor overload" <ul style="list-style-type: none"> <li>• Group signal for warning signals from temperature monitoring (KTY, PTC, thermal switch) or <math>I^2xt</math> monitoring.</li> </ul>
	TRUE   One of the monitoring modes for motor overload protection is active.
MI_bSpeedBelowThresholdC19 <a href="#">C02569/9</a>   BOOL	Status signal "Standstill reached"
	TRUE   The current speed is below the threshold set in <a href="#">C00019</a> .
MI_dnActualMotorCurrent_n DINT	Actual motor current <ul style="list-style-type: none"> <li>• 100 % = <math>I_{\max\_device}</math> (<a href="#">C00789</a>)</li> <li>• Display in <a href="#">C00780</a> in [A]</li> </ul>
MI_dnActualMotorVoltage_n DINT	Current motor voltage <ul style="list-style-type: none"> <li>• 100 % = 1000 V</li> <li>• Display in <a href="#">C00783</a> in [V]</li> </ul>
MI_dnActualMotorTorque_n DINT	Current motor torque <ul style="list-style-type: none"> <li>• 100 % = <a href="#">C00057/2</a></li> <li>• Display in <a href="#">C00774</a> in [Nm]</li> </ul>
MI_dnActualMotorSpeed_n DINT	Current speed of the motor shaft in [%] <ul style="list-style-type: none"> <li>• 100 % = Motor reference speed (<a href="#">C00011</a>)</li> </ul>
MI_dnActualMotorSpeed_s DINT	Current speed of the motor shaft in [rpm] <ul style="list-style-type: none"> <li>• Display in <a href="#">C00772</a></li> </ul>
MI_dnActualMotorPos_p DINT	Current position of the motor shaft in [increments] <ul style="list-style-type: none"> <li>• Display in <a href="#">C00770</a></li> </ul>
MI_dnActualDCBusVoltage_n DINT	Current DC-bus voltage <ul style="list-style-type: none"> <li>• 100 % = 1000 V</li> </ul>
MI_dnThermalLoadDevice_n DINT	Thermal device utilisation in [%] <ul style="list-style-type: none"> <li>• Current result of the <math>Ixt</math> calculation.</li> <li>• Display in <a href="#">C00064</a></li> <li>▶ <a href="#">Monitoring of the device utilisation</a> (□ 111)</li> </ul>
MI_dnThermalLoadMotor_n DINT	Thermal motor utilisation in [%] <ul style="list-style-type: none"> <li>• Current result of the <math>I^2xt</math> calculation.</li> <li>• Display in <a href="#">C00066</a></li> <li>▶ <a href="#">Motor monitoring (<math>I^2xt</math>)</a> (□ 218)</li> </ul>
MI_dnActualMotorFreq_s From V3.0 DINT	Current motor frequency in [Hz] The motor frequency corresponds to the field frequency [Hz]. Field frequency [Hz] = motor speed × number of motor pole pairs

# 5

## Motor interface

5.10

Internal interfaces | "LS\_MotorInterface" system block

Identifier <small>DIS code   data type</small>	Value/meaning
MI_dnActualFlux_n <small>DINT</small> <small>From V3.0</small>	Actual flux value
MI_bFlyingSyncBusy <small>C02569/13   BOOL</small> <small>From V3.0</small>	"Flying restart function active" status signal ▶ <a href="#">Flying restart function</a> (☰ 212)
	TRUE   Flying restart function is active
MI_bClampsActive <small>C02569/14   BOOL</small> <small>From V3.0</small>	Status signal "Clamping is active"
	TRUE   Clamping is active.
MI_bMagnetisationFinished <small>C02569/15   BOOL</small> <small>From V3.0</small>	Status signal "Motor magnetisation is completed" Note: This bit is <u>only</u> supported in the SLVC control mode (sensorless vector control).
	TRUE   Motor magnetisation is completed.

### 6 Encoder evaluation

This chapter contains information on how to use feedback systems for the motor control.



#### Danger!

If the encoder/resolver is used as motor encoder:  
In case of error, safe operation of the motor is no longer guaranteed!

When servo control is used:

- For the (open circuit) monitoring of the encoder/resolver for reasons of safety always the "Fault" response (Lenze setting) should be set!

When V/f control is used:

- For this type of motor control, the drive basically is to coast down after an encoder failure and may not stop, therefore the "Warning" response is to be set for the (open circuit) monitoring in this case!

Parameters for the (open circuit) monitoring:

- [C00580](#): Response to open circuit of encoder
- [C00586](#): Response to open circuit of resolver
- [C00601](#): Response to communication error of encoder



#### Note!

The encoder position is stored safe against mains failure in the memory module and is therefore known to the drive control even after the mains has been switched.

With regard to their position resolution, higher-level applications are based on the resolution of the encoder which is activated for position control.

#### Behaviour of the home position after mains switching

If the home position/information is also to be available after mains switching, the setting [C02652](#) = "1: Received" is required.

- Another condition for keeping the home position/information after mains switching is the compliance with the maximum permissible angle of rotation of the encoder, which can be set in [C02653](#).
- When resolvers or single-turn absolute value encoders are used and the mains is switched off (24 V supply off), the encoder may only be moved by ½ revolution since otherwise the home position will get lost due to the ambiguity of the encoder information.



#### Note!

A digital position encoder connected to the "LS\_Feedback" system block must have a position resolution of exactly 16 bits if a safety module SM301 is used together with the safe speed detection.

See also: [▶ Parameterising motor encoder](#) (□ 129)

# 6 Encoder evaluation

## 6.1 Internal interfaces | "LS\_Feedback" system block

### 6.1 Internal interfaces | "LS\_Feedback" system block

The **LS\_Feedback** system block provides the internal interfaces for the basic function "Encoder evaluation" in the function block editor.

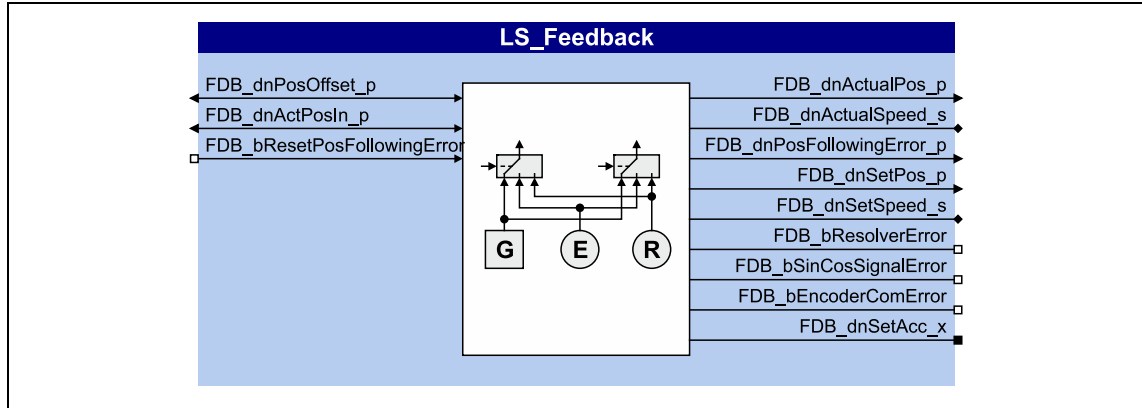

#### Inputs

Identifier	Data type	Information/possible settings		
FDB_dnPosOffset_p	DINT	Offset for position setpoint and actual position in [increments]		
FDB_dnActPosIn_p	DINT	External actual position in [increments] <ul style="list-style-type: none"> <li>For the selection of an external actual position with a corresponding position control.</li> </ul> ▶ <a href="#">Use of an external position encoder (242)</a>		
FDB_bResetPosFollowingError	BOOL	Input for deleting the following error <table border="1"> <tr> <td>True</td> <td>The position setpoint is equated with the actual position value.</td> </tr> </table>	True	The position setpoint is equated with the actual position value.
True	The position setpoint is equated with the actual position value.			

#### Outputs

Identifier	Value/meaning		
FDB_dnActualPos_p	Current position of the position encoder in [increments]		
FDB_dnActualSpeed_s	Current speed of the position encoder in [rpm]		
FDB_dnPosFollowingError_p	Current following error in [increments]		
FDB_dnSetPos_p	Set position calculated by active basic drive function in [increments] <ul style="list-style-type: none"> <li>Considering the motor mounting position.</li> <li>In the case of an active speed or torque control (instead of position control) the actual position (<i>FDB_dnActualPos_p</i>) is shown at this output.</li> </ul>		
FDB_dnSetSpeed_s	Setpoint speed calculated by active basic drive function in [rpm] <ul style="list-style-type: none"> <li>Considering the motor mounting position.</li> </ul>		
FDB_bResolverError	Status signal "Resolver error" <table border="1"> <tr> <td>TRUE</td> <td>A resolver error (e.g. open circuit) has occurred.</td> </tr> </table>	TRUE	A resolver error (e.g. open circuit) has occurred.
TRUE	A resolver error (e.g. open circuit) has occurred.		
FDB_bSinCosSignalError	Status signal "sine/cosine encoder error" <table border="1"> <tr> <td>TRUE</td> <td>A sine/cosine encoder error has occurred.</td> </tr> </table>	TRUE	A sine/cosine encoder error has occurred.
TRUE	A sine/cosine encoder error has occurred.		



# 6

## Encoder evaluation

6.1

Internal interfaces | "LS\_Feedback" system block

Identifier <small>DIS code   data type</small>	Value/meaning
FDB_bEncoderComError <small><a href="#">C02579/3</a>   BOOL</small>	Status signal "Encoder communication error" TRUE   An encoder communication error has occurred.
FDB_dnSetAcc_x <small>From V7.0</small>	DINT Setpoint acceleration calculated by active basic function <ul style="list-style-type: none"> <li>• Considering the motor mounting position.</li> <li>• For the basic functions <a href="#">Stop</a>, <a href="#">Manual jog</a>, <a href="#">Homing</a> and <a href="#">Positioning</a>, the internal acceleration resulting from the profile generation is output.</li> <li>• For the basic functions <a href="#">Quick stop</a>, <a href="#">Position follower</a> and <a href="#">Speed follower</a>, the acceleration from the differentiated setpoint speed is determined. <a href="#">C02562</a> serves to filter the determined acceleration.</li> <li>• With an active torque control or in a non-controlled operation (function states "Controller not ready" and "Error"), the value "0" is output.</li> </ul>

### 6.1.1 Use of an external position encoder

The *FDB\_dnActPosIn\_p* input serves to evaluate an external encoder (CAN, SSI, Profibus) for the position control.

- Via this input, a current actual position of an external encoder in [increments] can be directly transferred to the encoder evaluation.



#### How to activate the use of the external actual position:

On the **Application parameters**

tab in the dialog level *Overview* → *Drive interface* → *Machine parameters*:

1. Select the "Position controller active" setting in the **Position control structure** list field ([C02570](#)), so that the position encoder is evaluated.
2. Set "From application" in the **Position encoder selection** list field ([C00490](#)).



#### Note!

- Encoder inversion and offset selection *FDB\_dnPositionOffset\_p* also affect the external actual position.
- If the use of the external actual position preset via *FDB\_dnActPosIn\_p* is activated, the "Home position known" status (*HM\_bHomePosAvailable* = TRUE) is automatically set and homing with the basic function "Homing" cannot be activated anymore.
- If the traversing range ([C02528](#)) is set to "Modulo", the external actual position also has to be defined as modulo (0 ... cycle-1).

# 6 Encoder evaluation

## 6.2 Signal flow

### 6.2 Signal flow

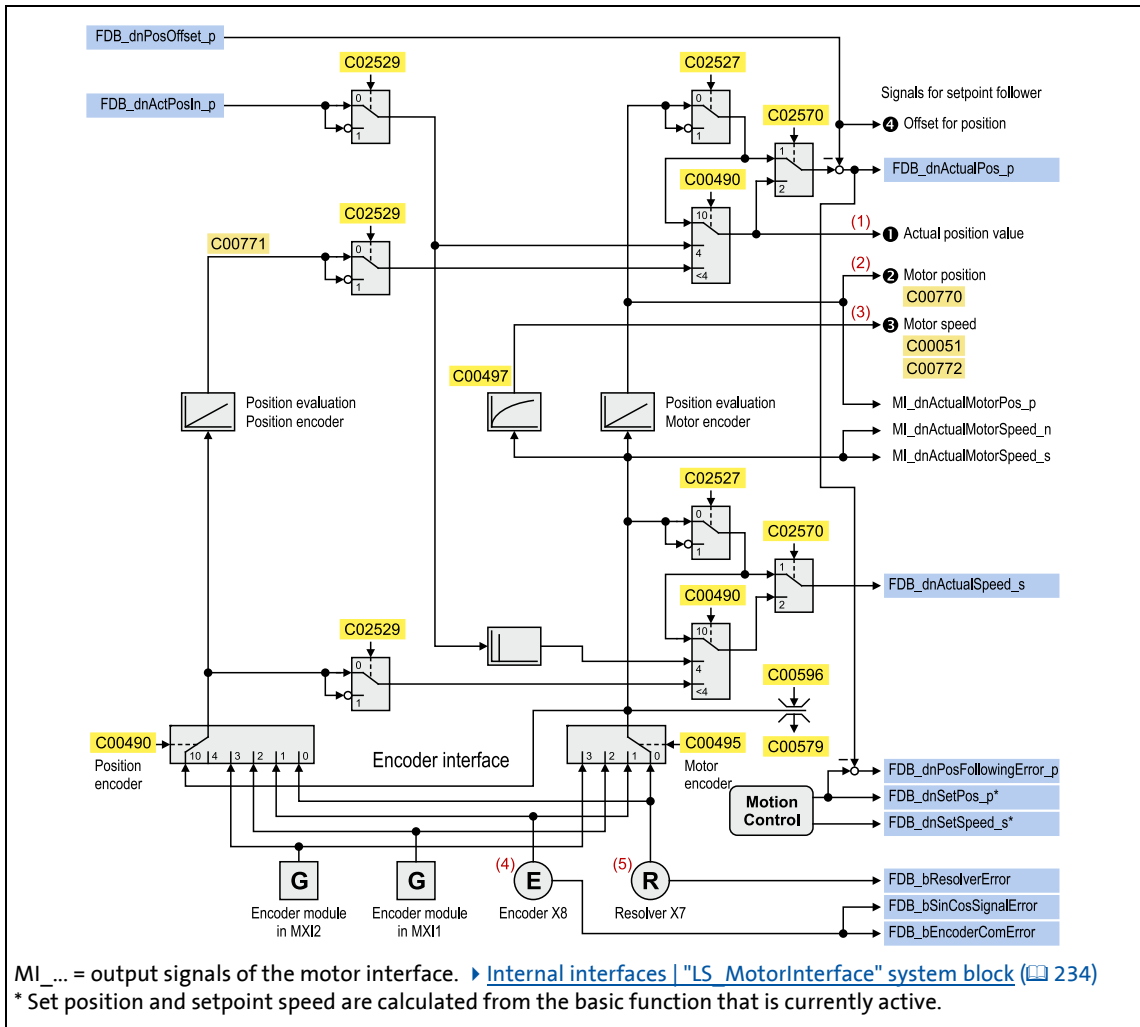

[6-1] Signal flow - encoder evaluation

#### Internal variables of the motor control (oscilloscope signals)

- The red numbers in brackets listed in the signal flow stand for internal variables of the motor control, which you can record by means of the [Oscilloscope](#) for purposes of diagnostics and documentation. ( 585 )

No.	Variable of the motor control	Meaning
(1)	Position.dnActualLoadPos	Actual position
(2)	Position.dnActualMotorPos	Current motor position
(3)	Speed.dnActualMotorSpeed	Current motor speed
(4)	Speed.dnActualEncoderSpeed	Current encoder speed
(5)	Speed.dnActualResolverSpeed	Current resolver speed

### 6.3 Parameter setting

Short overview of parameters for the encoder evaluation:

Parameters	Info	Lenze setting	
		Value	Unit
<a href="#">C00058/1</a>	Resolver pole position	-90.0	°
<a href="#">C00058/2</a>	Rotor displ. angle encoder	0.0	°
<a href="#">C00058/3</a>	Module pole position	0.0	°
<a href="#">C00080</a>	Number of resolver pole pairs	1	
<a href="#">C00416</a>	Resolver error correction	0	
<a href="#">C00417</a>	Dynamics of the resolver evaluation	100	%
<a href="#">C00418</a>	Activate resolver error compensation	Deactivated	
<a href="#">C00420</a>	Number of encoder increments	512	
<a href="#">C00421</a>	Encoder voltage	5.0	V
<a href="#">C00422</a>	Encoder type	Incremental encoder (TTL signal)	
<a href="#">C00423</a>	SSI encoder: Bit rate	400	kbps
<a href="#">C00424</a>	SSI encoder: Data word length	25	Bit
<a href="#">C00427</a>	TTL encoder signal evaluation	4x evaluation (A, B)	
<a href="#">C00435/1...8</a>	SSI encoder: Partword starting position	0	
<a href="#">C00436/1</a>	SSI encoder: partword length (partword 1)	31	
<a href="#">C00436/2...8</a>	SSI encoder: partword length (partwords 2...8)	0	
<a href="#">C00437/1...8</a>	SSI encoder: partword coding	Binary coded	
<a href="#">C00490</a>	Position encoder selection	Motor encoder	
<a href="#">C00495</a>	Motor encoder selection	Resolver X7	
<a href="#">C00497</a>	Speed act. val. time const.	2.0	ms
<a href="#">C00579</a>	Resp. to speed monitoring	Off	
<a href="#">C00580</a>	Resp. to encoder open circuit	Error	
<a href="#">C00586</a>	Resp. to resolver open circuit	Error	
<a href="#">C00601</a>	Resp. to encoder fault	Error	
<a href="#">C00621</a>	Resp. to angular drift of encoder	No response	
<a href="#">C02527</a>	Motor mounting direction	Motor rotating CW	
<a href="#">C02529</a>	Position encoder mounting direction	Encoder rotating CW	
<a href="#">C02570</a>	Position control structure	Phase controller is active	
<a href="#">C02572</a>	Speed setpoint (enc. eval.)	-	Unit/s
<a href="#">C02573</a>	Position setpoint (enc. eval.)	-	Unit
<a href="#">C02574</a>	Actual speed (encoder eval.)	-	Unit/s
<a href="#">C02575</a>	Actual position (enc. eval.)	-	Unit
<a href="#">C02576</a>	Following error	-	Unit
<a href="#">C02577</a>	External actual position	-	Unit
<a href="#">C02578</a>	Offset actual pos. value/setp.	-	Unit
<a href="#">C02760</a>	Activate Encoder	Deactivated	
<a href="#">C02761</a>	Resolution Multiturn	-	Rev.
<a href="#">C02762</a>	Encoder position	-	Steps.
<a href="#">C02763</a>	Encoder position	-	Rev.
<a href="#">C02764</a>	Encoder speed	-	rpm
<a href="#">C02765</a>	ENC_bError	-	
<a href="#">C02862/1</a>	Resolver: cos gain	100	%

Greyed out = display parameter

# 6 Encoder evaluation

## 6.3 Parameter setting

Parameters	Info	Lenze setting	
		Value	Unit
<a href="#">C02862/1</a>	Resolver: sine gain	100	%
<a href="#">C02863</a>	Resolver: Angle correction	0	

Greyed out = display parameter



### How to get to the dialog for setting the encoder evaluation parameters:

1. Go to the *Project view* of the »Engineer« and select the 9400 HighLine controller.
2. Select the **Application parameters** tab from the *Workspace*.
3. Click the button **All basic functions** in the *Overview* dialog level.
4. Click the button **Encoder evaluation** in the dialog level *Overview* → *All basic functions*.

### Parameterisation dialog in the »Engineer«

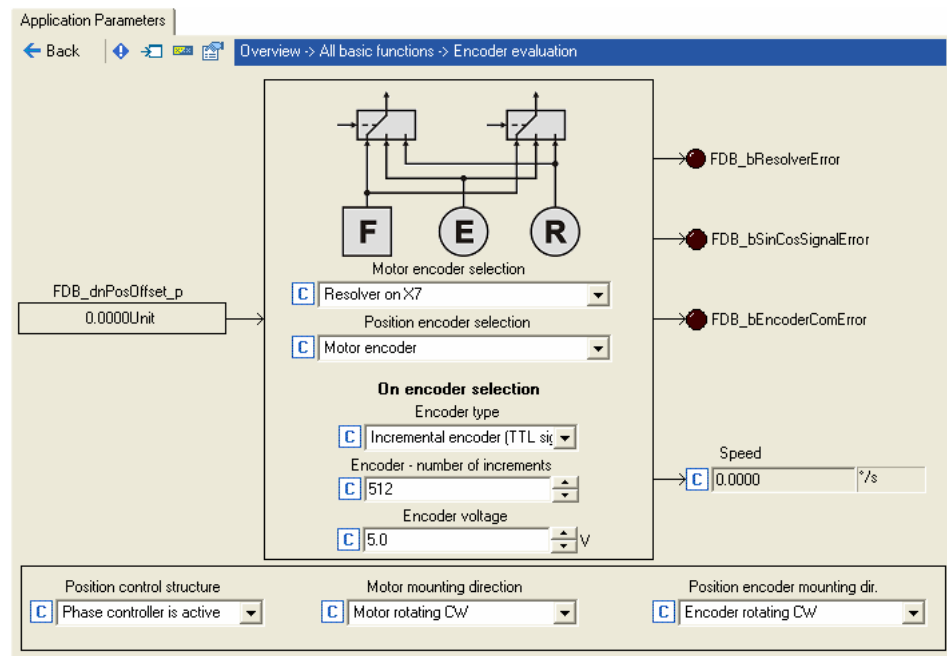

See also: [▶ Parameterising motor encoder \(129\)](#)

### 6.3.1 Controller configuration

The device interfaces for the encoder on the motor side and, if available, on the load side are directly assigned to the corresponding control according to the structure of the position control selected ([C02570](#)):

	Phase control (Lenze setting)	position control
<b>Cycle time:</b>	250 $\mu$ s	Application-dependent
<b>Dead time:</b>	Smaller dead time in the actual value channel	Same dead time for position setpoint and actual position
<b>Use:</b>	In positioning technology and single-axis applications or if only one encoder is used.	In multi-axis applications or if a position encoder is used in addition to the motor encoder.

- If only an encoder on the motor side is available, this "motor encoder" provides the actual value signals for the phase/position control and the speed control.
  - In this case both the angle control and the position control can be selected.
  - When selecting the position control, make sure that the position encoder selection "10: Motor encoder (C00495)" is set in [C00490](#). With this selection, the mounting position and the resulting gearbox factor are already considered.
  - The motor encoder supports the secondary servo control irrespective of the use for position and speed control (commutation).
- If an additional encoder is available on the load side, this "position encoder" only supports the position control and [C02570](#) accordingly has to be set to "Position controller active", so that the position encoder is evaluated.
  - The used position encoder must be set in [C00490](#).
  - The position encoder mounting direction must be set in [C02529](#).
  - The starting position of the position encoder can be set via the basic function "Homing".



#### Note!

When the basic function "Quick stop" is activated, the controller configuration is always switched over to angle control internally, irrespective of the setting in [C02570](#).

- If the basic function "Quick stop" is to be used, the gain of the phase controller ([C00254](#)) must also be set correctly for the "Position control" controller configuration.

For the technology applications for the interconnection via the "Electrical shaft", the controller configuration is set to position control in the default setting.

# 6 Encoder evaluation

## 6.3 Parameter setting

From software version V7.0 onwards, the selection "3: Position controller active" is available in [C02570](#).

- In contrast to the already existing selection "2: Position controller active (<= FW V5.xx)", this selection considers the gearbox factor.
- Further explanations on this can be obtained from the following table:

<a href="#">C02570 = 2: Position controller active (&lt;= FW V5.xx)</a>	<a href="#">C02570 = 3: Position controller active</a>
When the separate position encoder at the output end is used, the reference speed to the tool is assumed. This causes the acceleration and deceleration times not to refer to the motor but to the encoder. In order to re-establish the motor reference, the desired acceleration time of the corresponding function must be multiplied by the resulting gearbox factor.	When the separate position encoder at the output end is used, the reference speed is referred to the motor. Thus, all acceleration and deceleration times are calculated with regard to the reference speed at the motor.
<b>Example:</b> <ul style="list-style-type: none"><li>• Motor reference speed (C00011) = 3000 rpm</li><li>• Resulting gearbox factor = 10</li><li>• Acceleration time = 1 s</li></ul> With 10 % setpoint selection:	
<ul style="list-style-type: none"><li>• Motor speed = 100 % (3000 rpm)</li><li>• Tool speed = 300 rpm</li><li>• Acceleration time up to 10 % setpoint selection (100 % motor speed) = 0.1 s</li></ul>	<ul style="list-style-type: none"><li>• Motor speed = 10 % (300 rpm)</li><li>• Tool speed = 30 rpm</li><li>• Acceleration time up to 10 % setpoint selection (10 % motor speed) = 0.1 s</li></ul>

# 6 Encoder evaluation

## 6.3 Parameter setting

### 6.3.2 System with motor encoder

No encoder is installed on the load side. The motor position (angle of rotation) and motor speed are detected via the motor encoder selected in [C00495](#) and are converted with regard to the load side.

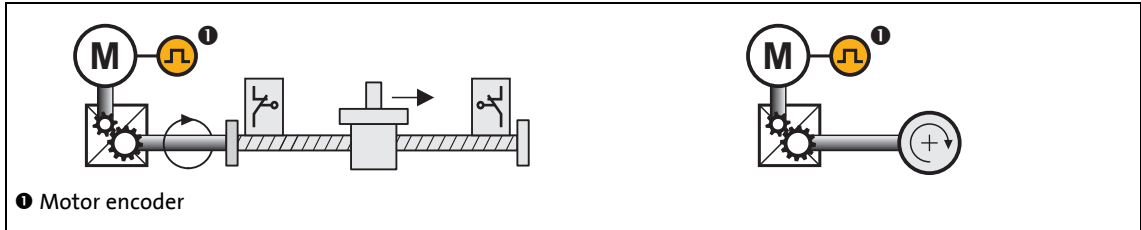

[6-2] Schematic diagram - feedback with position encoder = motor encoder

The actual position and actual speed values on the machine side result from the conversion via the gearbox factor on the motor side ([C02520/C02521](#)) and the feed constant ([C02524](#)).

See also:

- ▶ [Gearbox ratio](#) (📖 34)
- ▶ [Feed constant](#) (📖 39)



### 6.3.3 System with motor encoder and position encoder

The optional position encoder is used as a feedback for the position control and transmits the position of slide or drive roll to the controller.

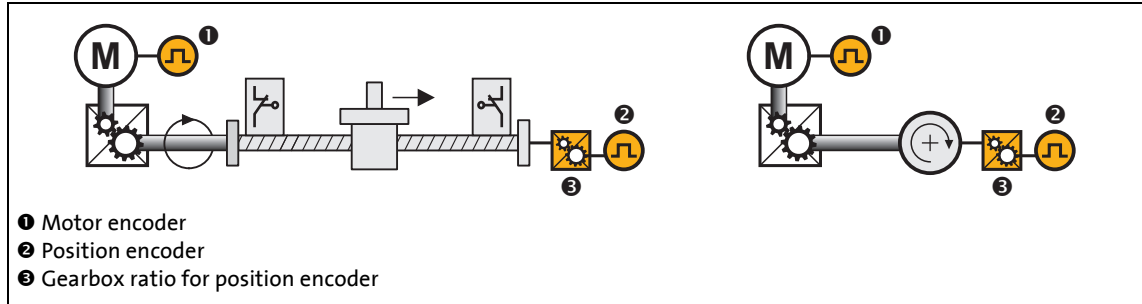

[6-3] Schematic diagram - feedback with separate position encoder

In this case, the actual position and actual speed values on the machine side result from the conversion of the position encoder position via the resulting gearbox factor (ratio of the motor speed to the position encoder speed; display in [C02531/3](#)) and the feed constant ([C02524](#)).



#### How to activate the use of a separate position encoder:

On the **Application parameters**

tab in the dialog level *Overview* → *Drive interface* → *Machine parameters*:

1. Select the "Position controller active" setting in the **Position control structure** list field ([C02570](#)), so that the position encoder is evaluated.
2. Select the position encoder available in the **Position encoder selection** list field ([C00490](#)).
3. Select the gearbox ratio of the position encoder (ratio of load speed to encoder speed) as a quotient (numerator/denominator) which results from the resulting teeth number:
  - Enter numerator in the input field **Gearbox fact. num.: Pos. enc.** ([C02522](#)).
  - Enter denominator in the input field **Gearbox fact. denom.: Pos. enc.** ([C02523](#)).
4. If required, adapt the position encoder mounting direction via the **Position encoder mounting direction** list field ([C02529](#)). The position encoder mounting direction is preset to "Encoder rotating CW".



#### Tip!

In [C02531/2](#) the gearbox factor is displayed in decimal format.

Important reference variables converted to the load side:

- Motor reference speed ([C00011](#)) → Load reference speed ([C02542](#))
- Reference torque ([C00057/2](#)) → Load reference torque ([C02543](#))

If a position encoder is used as well as the motor encoder, it is essential that position control is used instead of angle control ([C02570](#) = 2 or 3).

Rotative encoders as well as linear distance measuring devices can be used as position encoders.

The feedback from position encoders (SSI-, EnDat-, TTL-, Sin/Cos-, Hiperface encoder) is transferred via encoder input X8, with the exception of fieldbus encoders.

If a fieldbus encoder is used, the fieldbus interface is used for position feedback.

The actual position value is passed on to the position controller via the system block available for

---

encoder evaluation **LS\_Feedback**. For this purpose, the actual position value must be connected to the input *FDB\_dnActPosIn\_p*.

**Note!**

The use of an SSI encoder is a special case:

- Position feedback takes place via encoder input X8 as is the case with most position encoders.
- Processing of the actual position value is carried out in the same way as in the case of a fieldbus encoder. The actual position is passed on to the position controller via the system block available for encoder evaluation **LS\_Feedback**. For this purpose, the actual position value must be connected to the input *FDB\_dnActPosIn\_p*.

### 6.3.4 Position feedback with a linear distance measuring device

This function extension is available from software version V4.0!

Linear distance measuring devices (e.g. with Hiperface® or EnDat interface) are only used for additional position feedback in the case of servo-controlled drives. For speed and current control, a motor encoder is always necessary.

For applications with low requirements regarding dynamic response and speed accuracy, the use of sensorless V/F control (VFCplus) and position feedback for position control is possible.

#### 6.3.4.1 Conversion from linear to rotative encoder variables

Like the signals of rotative position encoders, the signals of linear distance measuring devices are read in at encoder input X8. The actual position value of these usually optical encoders is thus directly available for position control. Additional block interconnection is not necessary.

Evaluation at encoder input X8 is designed for rotary encoders. In order to adapt the linear system, conversion to (notional) rotative values, which have to be entered in the code, is necessary.

##### Conversion for the number of encoder increments in [C00420](#):

In the case of linear distance measurement devices, the encoder resolution is usually indicated in the form of graduations in [ $\mu\text{m}$ ] or as a number of increments per millimetre [ $\text{inc}/\text{mm}$ ].

The following rule of thumb can be used to determine the number of encoder increments [C00420](#):

$$\begin{aligned} \text{Number of encoder increments} &= \frac{\text{Feed constant [units/rev]}}{\text{Encoder graduation [units]}} \\ \text{C00420} = \text{INT number of encoder increments} &= \frac{\text{C02524}}{\text{Encoder graduation}} \end{aligned}$$

[6-4] Determination of the number of encoder increments of linear distance measuring devices

The integer value (INT = integer part of the calculation) must be entered in [C00420](#). The resulting rounding-off error is corrected by means of the position encoder gearbox factor ([C02522](#) / [C02523](#)) in the machine parameters.

See ▶ [Determination of the position encoder gearbox factor of linear distance measuring devices](#)

The resulting maximum position which can be shown can be checked in [C02539](#).

The maximum speed that can be shown is indicated in [C02540](#).

If the necessary speeds and positions for the application can no longer be shown, [C00420](#) can be enlarged. The internal resolution is thus decreased.

# 6 Encoder evaluation

## 6.3 Parameter setting

### Calculation of the position encoder gearbox factor [C02522](#) and [C02523](#)

Please note that, when the number of encoder increments in the numerator of the following formula is indicated, the value with decimal places must be given whereas, in the denominator, the integer (INT = integer) is used for purposes of calculation:

$$n \text{ encoder - gearbox factor} = \frac{\text{Number of encoder increments (incl. decimal)}}{\text{Number of encoder increments (integer)}}$$

$$\frac{84823}{84820} = \frac{\text{Number of encoder increments (incl. decimal plac)}}{C00420}$$

[6-5] Determination of the position encoder gearbox factor of linear distance measuring devices

### Example: Position encoder feedback with a laser distance measuring device

The current position of a positioning unit is detected with a laser distance measuring device (e.g. »DME5000«) with a Hiperface® interface. A graduation of 0.1 mm has been parameterised in the distance measuring device.

The positioning unit is moved by 848.23 mm in an axial direction for each revolution of the slip-free drive roll. The current motor speed is detected by a resolver.

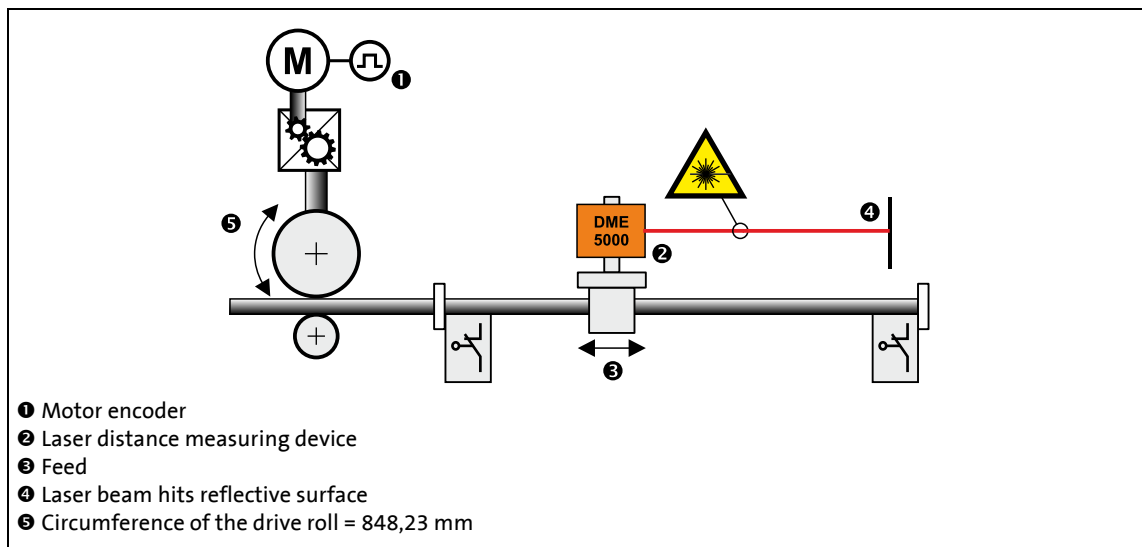

[6-6] Schematic diagram of feedback with a laser distance measuring device

Short overview of the parameters:

Parameters	Info	Lenze setting	
		Value	Unit
<a href="#">C00420</a>	Number of encoder increments	8482	
<a href="#">C00422</a>	Encoder type	Absolute value encoder (Hiperface)	
<a href="#">C00490</a>	Position encoder selection	Encoder on X8	
<a href="#">C00495</a>	Motor encoder selection	Resolver on X7	
<a href="#">C02522</a>	Gearbox factor numerator: position encoder	84823	-
<a href="#">C02523</a>	Gearbox factor denominator: position encoder	84820	
<a href="#">C02524</a>	Feed constant	848.23	mm
<a href="#">C02570</a>	Position control structure	Position controller is active	

See also: [► Feed constant \(39\)](#)

### 6.3.5 Adaptation of the resolver evaluation dynamics

This function extension is available from software version V5.0 onwards!

---

The resolver evaluation of the controller is adapted to the resolver types mounted in Lenze motors and offers a good compromise between the dynamic performance and interference suppression. If the resolver is used as a speed feedback system, the dynamic performance of the resolver evaluation determines, among other things, the maximum speed controller gain by means of which stable operation is possible.

In a system with an EMC-compliant structure (low interference), you can increase the dynamic performance of the resolver evaluation in [C00417](#) without a loss in quality in the speed signal. By increasing [C00417](#), the evaluation is rendered more dynamic, and thus the speed controller gain  $V_p$  ([C00070](#)) is also increased without leaving the stable operating range.

The acceleration of the evaluation depends on the cable length, the resolver, and the quality of the electrical shielding. In many cases, a setting of [C00417](#) = 300 % is possible which can double the speed controller gain. The higher gain in the speed controller may reduce following errors.

When a resolver with a number of pole pairs  $> 1$  ([C00080](#)  $> 1$ ) is used, it may be necessary to increase the dynamics of the resolver evaluation [C00417](#). The following rule of thumb applies for the parameterisation:

$$C00417 = 100\% \times \text{Value in } C00080$$

If an SM301 safety module is used to monitor the equipment, a parameterised value in [C00417](#) of  $> 500\%$  can cause incorrect triggering of the safety module. A value which is too high must be decreased in order to eliminate incorrect triggering.

- See also:*
- ▶ Servo control (SC): [Optimising the speed controller](#) (□ 150)
  - ▶ Sensorless vector control (SLVC): [Optimising the speed controller](#) (□ 177)

### 6.3.6 Parameterisation of an unknown Hiperface® encoder

This function extension is available from software version V11.0!

---

Application: A Hiperface® encoder is to be used with the controller, the current firmware of which has not (yet) been stored permanently.



#### How to parameterise a Hiperface® encoder unknown to the controller:

1. Determine the type code of the encoder.
  - If the encoder has already been connected and read out, the type code is indicated in [C00413](#).
  - Alternatively, the type code can be obtained from the manufacturer or gathered from the documentation for the encoder.
2. Set the type code of the encoder in [C00414](#).
  - Please observe that the decimal format has to be used for the setting. The type codes provided by the manufacturer, however, are in the hexadecimal format.
3. If a multi-turn encoder is used, set the number of displayable resolutions in [C00415](#).
  - This value can also be gathered from the documentation for the encoder.
4. Set the number of encoder increments in [C00420](#).
  - This point must be executed last since it initiates a renewed readout of the encoder.

### 6.3.7 Parameterisation of a Hiperface® encoder with increased initialisation time

This function extension is available from software version V11.0!

---

Application: A Hiperface® encoder is to be used at the controller which has an initialisation time that differs from the Hiperface specification. This applies to e.g. the absolute value encoders of the types SEK37, SEL37, SEK52 and SEL52 of the Sick company.

In case of Hiperface® encoders with increased initialisation time, an error message occurs after switching on the controller [0x007b001a](#) ("absolute value encoder: communication error"). This error can be acknowledged but occurs again after every switch-on.

In order to avoid the error message, it is possible to consider the increased initialisation time of the encoder in [C00412](#).

For the absolute value encoders of the types SEK37, SEL37, SEK52 and SEL52 of the Sick company, the required initialisation time in [C00412](#) is = 1200 ms.

The initialisation time required for each case can be obtained from the respective absolute value encoder data sheet.

### 6.3.8 Use of an SSI encoder at X8

This function extension is available from software version V5.0 onwards!

From software version V5.0 all encoders at X8 using the Stegmann SSI protocol are supported.

- Supported bit rates for the SSI communication: 150 ... 1000 kbits
- Supported data word widths: 1 ... 31 bits (effective)
- Supported output code of the SSI encoder: Gray or binary
- The SSI encoder can be used as position encoder or master encoder with a minimum cycle time of 1 ms.
- The SSI encoder can be supplied via X8 up to a maximum voltage of 12 V and a maximum current of 0.25 A.
- The SSI data words received are provided to the application via the [LS SsiEncoderX8](#) system block for further processing within the function block editor.



#### Note!

The [LS SsiEncoderX8](#) SB is only provided within controllers with a MM3xx or MM4xx memory module.



#### How to parameterise the SSI encoder at X8:

1. Set the supply voltage of the SSI encoder used in [C00421](#).
2. Set the selection "4: SSI encoder" as encoder type in [C00422](#).
3. Set the bit rate for SSI communication in [C00423](#).
  - For SSI protocols, the permissible baud rate is reduced if the cable length is increased. A safe bit rate must be set, depending on the length of the used encoder cable and the electromagnetic interference level.
  - Lenze setting: 400 kbits (for encoder cables with a length of up to ≈ 50 meters)
4. Set the data word width in [C00424](#), i. e. the number of data bits that is used for the transmission of a complete SSI data packet.
  - Lenze setting: 25 bits (Stegmann multiturn SSI encoder)
5. Optionally: Split the SSI data word received into partwords and connect a data conversion from Gray into binary code, which may be required (see the following subchapters).

### 6.3.8.1 "LS\_SsiEncoderX8" system block

The **LS\_SsiEncoderX8** system block provides the SSI data words received to the application for further processing in the function block editor.



#### Note!

- The **LS\_SsiEncoderX8** SB is only provided within controllers with a MM3xx or MM4xx memory module.
- If a position is transmitted in the SSI data word, it is output in an unchanged manner with regard to the position format by the **LS\_SsiEncoderX8** SB. For a use of the SSI encoder as position encoder the position has to be converted into the 9400 format afterwards by means of the **L\_EsEncoderConv** FB.

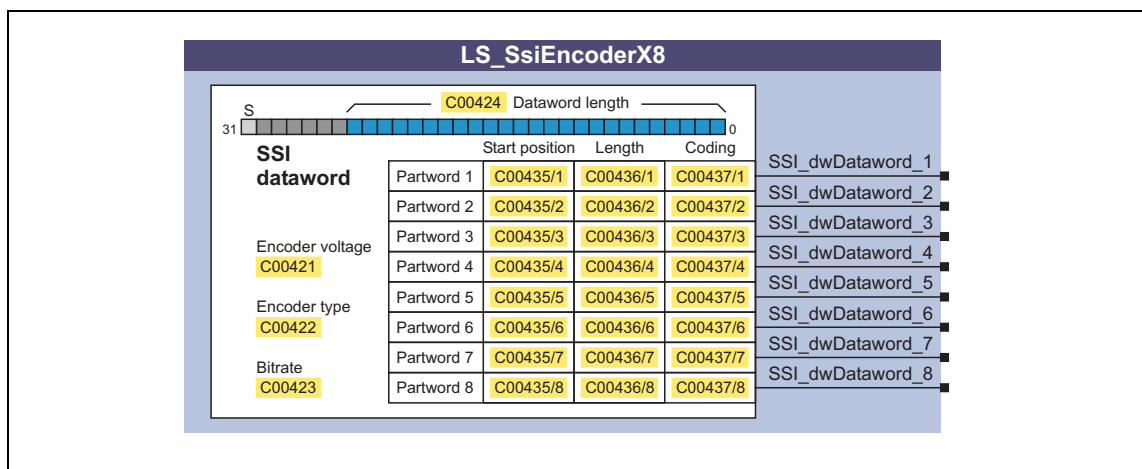

#### Outputs

Identifier	Data type	Value/meaning
SSI_dwDataword_1	DWORD	SSI partword 1 • In the Lenze setting the complete SSI data word received is shown at this output without a conversion of the data format.
SSI_dwDataword_2 ... SSI_dwDataword_8	DWORD	SSI partwords 2 ... 8 • In the Lenze setting these outputs are deactivated. ▶ <a href="#">Dividing the SSI data word into partwords</a> (📖 257)

#### Gray-binary conversion

If an SSI encoder with Gray coding is used, a data conversion of Gray-to-binary code can be connected in **C00437/1...8** individually for each output of the **LS\_SsiEncoderX8** SB, and thus for each partword.

- In the Lenze setting "Binary coded" there is no conversion, i. e. an SSI encoder with binary coding is expected.



### 6.3.8.2 Dividing the SSI data word into partwords

The [LS\\_SsiEncoderX8](#) SB can be configured so that it splits up the SSI data word received by the encoder interface into several partwords.

- A separation into partwords is reasonable if the SSI data word also contains other data (like for instance fault or status information) in addition to the position.
- The max. 8 possible partwords are fixedly assigned to the outputs *SSI\_dwDataword\_1* ... *SSI\_dwDataword\_8*.
- The partwords are configured via the following parameters:

Parameters	Info
<a href="#">C00435/1...8</a>	<b>Starting position for partwords 1 ... 8</b> In order to be able to display the individual components of the SSI data word received at different outputs, this code serves to specify the bit position with which the partword for the respective output starts for the eight possible outputs of the <a href="#">LS_SsiEncoderX8</a> SB. Subcode 1 is fixedly assigned to the first output, subcode 2 to the second output, etc.
<a href="#">C00436/1...8</a>	<b>Length of the partwords 1 ... 8</b> Apart from the position of the first bit, also the bit length of each partword is important for the separation. A length of zero means that no partword is to be shown at the corresponding output (output = 0). Here also subcode 1 is fixedly assigned to the first output, subcode 2 to the second output, etc.

- In the Lenze setting the complete SSI data word received is shown at the output *SSI\_dwDataword\_1*:

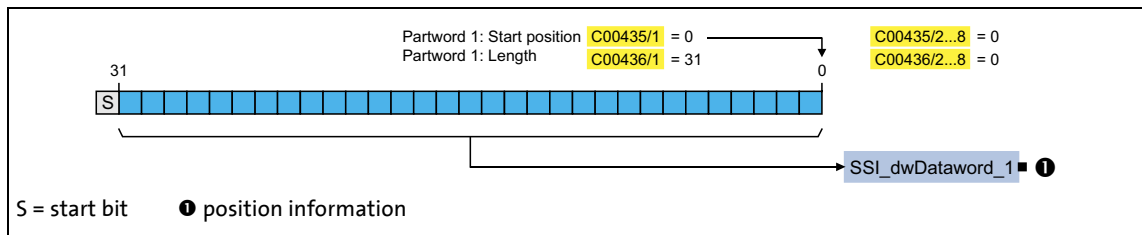

[6-7] Example 1: Lenze setting

- The following example shows the parameterisation required to split up the SSI data word received into three partwords (here status information, error bit, and position information):

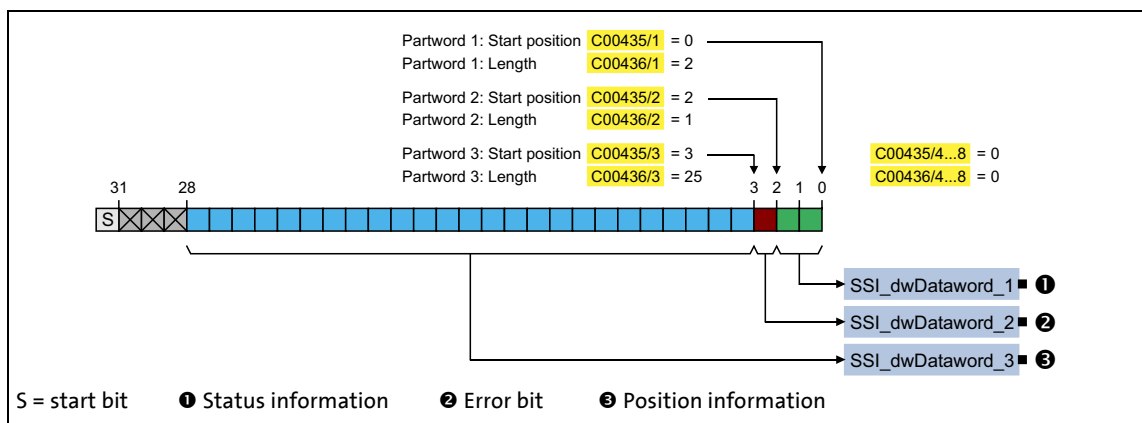

[6-8] Example 2: Splitting up the SSI data word received into three partwords

### 6.3.8.3 Linear distance measuring devices with SSI protocol

Linear distance measuring devices provide the position directly in a physical unit of length (e.g. [mm]). An incremental position must be sent to the position controller via the system block

**LS\_Feedback.** The reference of this incremental position corresponds to a value of 65536 (Lenze setting: [C00100](#) = 16) in the case of a revolution at the output end.

The necessary conversion of the position value can be carried out by means of the block **L\_EsEncoderConv**. The block **L\_EsEncoderConv** is designed for rotary encoders. Conversion to (notional) rotative values is therefore necessary for the adaptation of linear distance measuring devices. The results of the conversion must be entered in the code.

#### Conversion for the number of encoder increments in C05273:

In the case of linear distance measurement devices, the encoder resolution is usually indicated in the form of graduations in [ $\mu\text{m}$ ] or as a number of increments per millimetre [ $\text{inc}/\text{mm}$ ].

The following rule of thumb can be used to determine the number of encoder increments C05273:

$$\text{Number of encoder increments} = \frac{\text{Feed constant [units/rev]}}{\text{Encoder graduation [units]}}$$

$$\text{C05273} = \text{INT number of encoder increments} = \frac{\text{C02524}}{\text{Encoder graduation}}$$

[6-9] Determination of the number of encoder increments of linear distance measuring devices with SSI protocol

The integer (INT = integer part of the calculation) must be entered in C05273. The resulting rounding-off error is corrected by means of the position encoder gearbox factor ([C02522](#) / [C02523](#)) in the machine parameters.

▶ [Determination of the position encoder gearbox factor of linear distance measuring devices with SSI protocol](#)

The resulting maximum position which can be shown can be checked in [C02539](#).

The maximum speed that can be shown is indicated in [C02540](#).

If the necessary speeds and positions for the application can no longer be shown, C05273 can be enlarged. The internal resolution is thus decreased.

#### Calculation of the position encoder gearbox factor [C02522](#) and [C02523](#)

Please note that, when the number of encoder increments in the numerator of the following formula is indicated, the value with decimal places must be given whereas, in the denominator, the integer (INT = integer) is used for purposes of calculation:

$$\text{n encoder - gearbox factor} = \frac{\text{Number of encoder increments (incl. decimal)}}{\text{Number of encoder increments (integer)}}$$

$$\frac{\text{!522}}{\text{!523}} = \frac{\text{Number of encoder increments (incl. decimal plac)}}{\text{C05273}}$$

[6-10] Determination of the position encoder gearbox factor of linear distance measuring devices with SSI protocol

### Example: Position encoder feedback with an SSI linear distance measuring device

The current position of a positioning unit is detected with a laser distance measuring device (e.g. »DME5000«) with an SSI interface. A graduation of 0.1 mm has been parameterised in the linear distance measuring device.

The positioning unit is moved by 848.23 mm in an axial direction for each revolution of the slip-free drive roll. The current motor speed is detected by a resolver.

A position offset of 100 mm must be taken into account due to installation of the distance measuring device and the reflector.

The lower 24 bits of the SSI data word contain information coded in Gray.

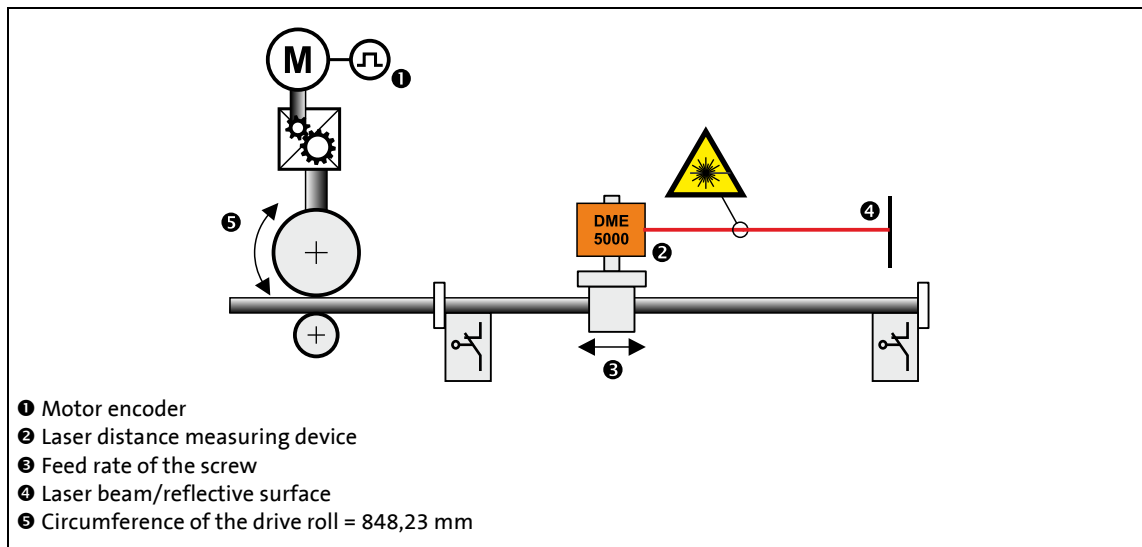

[6-11] Schematic diagram of feedback with laser distance measuring device DME5000

The Multiturn resolution (C05274) that is set must allow the entire traversing range of the application to be represented and must also ensure that the display limit in the 9400 device is not exceeded.

- Minimum Multiturn resolution.  
 $C05274 = \text{Maximum traversing range} / \text{feed constant} = 59$
- Maximum Multiturn resolution  
 $C05274 = 2^{31}-1 / \text{resolution of Singleturn} = 253181$

### Required FB interconnection

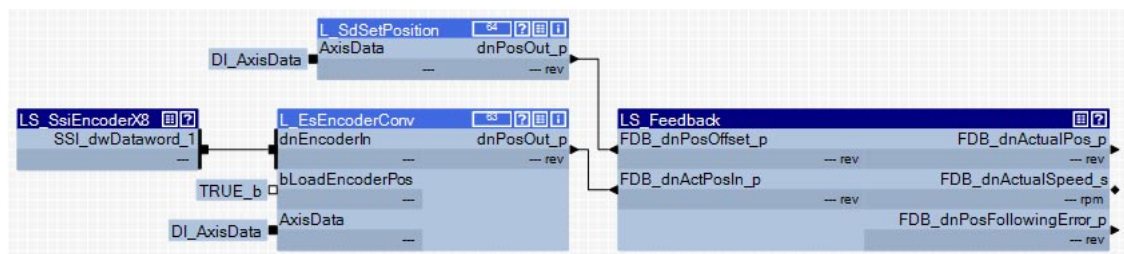

Short overview of the parameters:

Parameters	Info	Lenze setting	
		Value	Unit
<a href="#">C00422</a>	Encoder type	SSI encoder	
<a href="#">C00423</a>	SSI encoder: Bit rate	400	kbps
<a href="#">C00424</a>	SSI encoder: Data word length	24	Bit
<a href="#">C00435/1</a>	SSI enc.: Partword 1 start	0	
<a href="#">C00436/1</a>	SSI enc.: Partword 1 length	24	
<a href="#">C00437/1</a>	SSI enc.: Partword 1 coding	gray coded	
<a href="#">C00490</a>	Position encoder selection	Encoder on X8	
<a href="#">C00495</a>	Motor encoder selection	Resolver on X7	
<a href="#">C02522</a>	Gearbox factor numerator: position encoder	84823	
<a href="#">C02523</a>	Gearbox factor denominator: position encoder	84820	
<a href="#">C02524</a>	Feed constant	848.23	mm
<a href="#">C02570</a>	Position control structure	Position controller is active	
C04276	Position offset at <i>FDB_dnPosOffset_p</i>	100	mm
C05271	32-bit encoder signal		
C005273	Single turn resolution	8482	Steps/rev
C05274	Resolution Multiturn	60	Rev

### 6.3.9 Rotative encoder with SSI protocol

In accordance with the parameterisation of the system block **LS\_SsiEncoderX8**, the position information of the encoder is available in a partword and only has to be sent to the position controller via the SB **LS\_Feedback**.

In accordance with the Lenze setting of the position encoder gearbox factor ([C02522](#) = 1, [C02523](#) 1 = 1), it is expected that one encoder revolution corresponds to one rotation at the output end, i.e. to a feed rate in accordance with the feed constant [C02524](#).

The position information from the SSI data word is converted to the internal scale with the function block **L\_EsEncoderConv**, with which a certain machine position can be set as the reference/starting position. The parameterisation of the block makes it possible for the position to be reconstructed after mains switching. This is necessary if the absolute encoder display range of e.g. 4096 revolutions has been left.

#### Example: Material feed with length measurement by means of measuring wheel and SSI encoder

The current position of the material of a feed unit is detected with a rotative SSI encoder. One encoder revolution corresponds to one revolution of the measuring wheel (400 mm).

Every time the slip-free drive roll revolves, the material is moved 1200 mm in an axial direction. The current motor speed is detected by a resolver.

The lower 24 bits of the SSI data word contain the position information coded in Gray. The SSI encoder supplies 4096 gradations per revolution and has an absolute display range of 4096 revolutions.

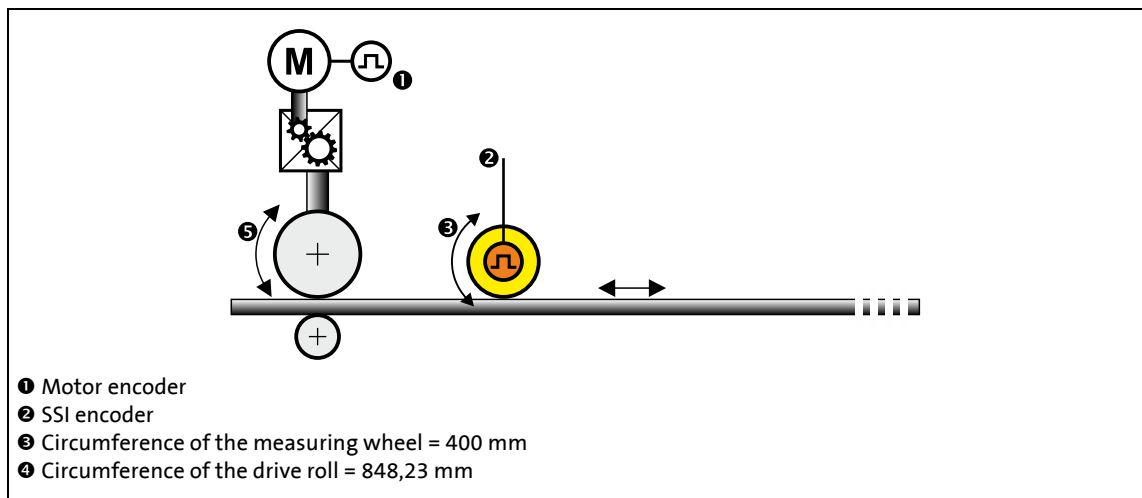

[6-12] Schematic diagram of feedback with laser distance measuring device DME5000

#### Required FB interconnection

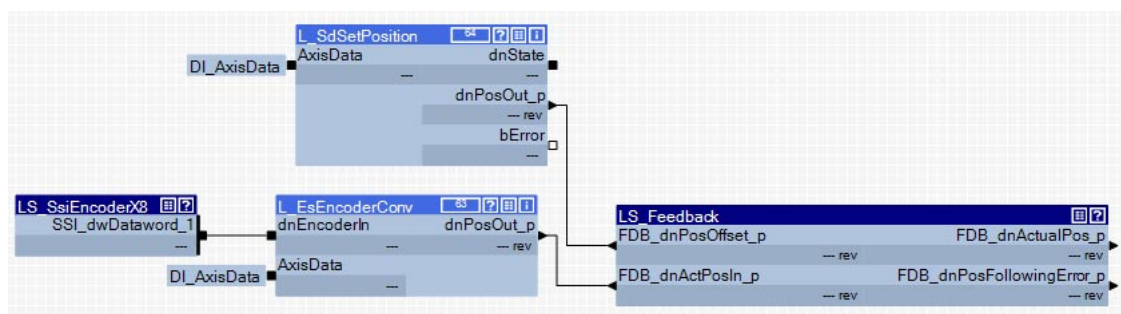

Short overview of the parameters:

Parameters	Info	Lenze setting	
		Value	Unit
<a href="#">C00422</a>	Encoder type	SSI encoder	
<a href="#">C00423</a>	SSI encoder: Bit rate	400	kbps
<a href="#">C00424</a>	SSI encoder: Data word length	24	Bit
<a href="#">C00435/1</a>	SSI enc.: Partword 1 start	0	
<a href="#">C00436/1</a>	SSI enc.: Partword 1 length	24	
<a href="#">C00437/1</a>	SSI enc.: Partword 1 coding	gray coded	
<a href="#">C00490</a>	Position encoder selection	Encoder on X8	
<a href="#">C00495</a>	Motor encoder selection	Resolver on X7	
<a href="#">C02522</a>	Gearbox factor numerator: position encoder	1200	
<a href="#">C02523</a>	Gearbox factor denominator: position encoder	400	
<a href="#">C02524</a>	Feed constant	1200	mm
<a href="#">C02570</a>	Position control structure	Position controller is active	
C05271	Encoder evaluation	32-bit encoder signal	
C05272	Encoder mounting position	Left	
C05273	Single turn resolution	4096	Steps/rev
C05274	Resolution Multiturn	4096	Rev

### 6.3.10 Provision of the encoder signal of input X8

This function extension is available from software version V7.0!

The **LS\_EncoderX8** system block serves to provide the encoder signal of input X8 to the application, independent of the selected feedback system for the motor encoder and position encoder.

#### Application cases:

- High-resolution speed encoder as master encoder /value, correcting signal, ...
- Absolute value encoder for length measurements
- Display of the absolute encoder value without considering an offset



#### Note!

For SSL encoders, the **LS\_SsiEncoderX8** system block must be used. ▶ [Use of an SSI encoder at X8 \(📄 255\)](#)

#### 6.3.10.1 System block "LS\_EncoderX8"

The **LS\_EncoderX8** system block provides the input X8 to the application in the function block editor.

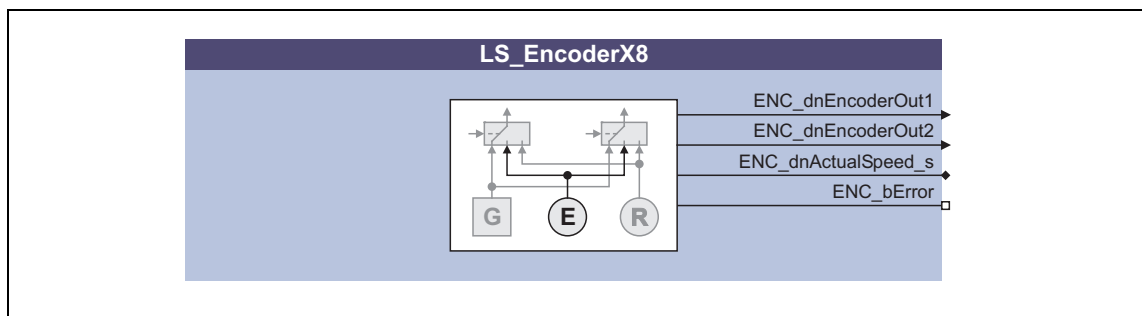

#### Outputs

Identifier <small>DIS code   data type</small>	Value/meaning		
ENC_dnEncoderOut1 <small>C02762   DINT</small>	Display of the current encoder position (steps) within one revolution • 1 revolution $\equiv 2^{32}$ bits <b>Note:</b> In order to convert the encoder information/position into a position_p in the internal measuring system, connect both outputs <i>ENC_dnEncoderOut1</i> and <i>ENC_dnEncoderOut2</i> with the inputs <i>dnEncoderIn</i> and <i>dnEncoderIn2</i> of the FB <b>L_EsEncoderConv</b> . A storage with mains failure protection of the position signal is also processed via this FB.		
ENC_dnEncoderOut2 <small>C02763   DINT</small>	Display of all revolutions of the encoder (only with Multiturn) • After the max. presentable revolutions have been reached, the value jumps back to "0". • <a href="#">C02761</a> shows the max. presentable revolutions of the MultiTurn encoder (encoder-dependent). • In case of SingleTurn, the value "0" is always output.		
ENC_dnActualSpeed_s <small>C02764   DINT</small>	Current encoder speed in [rpm]		
ENC_bError <small>C02765   BOOL</small>	Status signal "Encoder error" <table border="1" style="margin-left: auto; margin-right: auto;"> <tr> <td>TRUE</td> <td>An encoder error has occurred.</td> </tr> </table>	TRUE	An encoder error has occurred.
TRUE	An encoder error has occurred.		

### 6.3.10.2 Activate evaluation

[C02760](#) serves to activate the evaluation of the encoder signal of input X8.

- When the evaluation is activated, the encoder parameterised in [C00422](#) is read in.
  - At the same time, the monitoring functions are active. If no encoder is available, the corresponding monitoring functions are triggered.
- When the evaluation is deactivated, the outputs of the system block are reset.
  - Monitoring is deactivated depending on the position encoder selection ([C00490](#)) and the motor encoder selection ([C00495](#)).

#### Monitoring

The monitoring functions depend on the encoder type selected in [C00422](#) and do not differ from the existing monitoring functions:

- Open circuit of encoder (response: [C00580](#))
- [Encoder angular drift monitoring](#) (📖 267)
- Encoder communication error (*FDB\_bEncoderComError*; response: [C00601](#))
- Sine/cosine encoder error (*FDB\_bSinCosSignalError*)
- Group signal for errors as process date (*ENC\_bError*)

#### Conditioning of the encoder signal

- The encoder signal is conditioned to a position (including a storage with mains failure protection) within the application using the **FB L\_EsEncoderConv**:
  - Interconnection of the *ENC\_dnEncoderOut1* output signal with the *dnEncoderIn* input of the **FB L\_EsEncoderConv**.
  - Interconnection of the *ENC\_dnEncoderOut2* output signal with the *dnEncoderIn2* input of the **FB L\_EsEncoderConv**.
  - Additional parameter setting of the **FB L\_EsEncoderConv**:
    - Mode selection: *Cxxxxx* = 1
    - Number of revolutions transmitted from [C02761](#)
  - The (optional) reconstruction of the position after mains switching is also made by the **FB L\_EsEncoderConv**.
- In contrast, the conditioning of the encoder signal to a speed is directly made in the [LS\\_EncoderX8](#) system block.
  - The current encoder speed is provided at the *ENC\_dnActualSpeed\_s* output in [rpm] (display parameter: [C02764](#)).
- TouchProbe function is not supported (continues to be only available for motor and position encoders).
- If the encoder at X8 is simultaneously used as motor or position encoder, the "raw value" of the encoder is continued to be output.

#### Display parameter

Parameters	Info	Lenze setting	
		Value	Unit
<a href="#">C02761</a>	Resolution Multiturn	-	Rev.
<a href="#">C02762</a>	Encoder position: Steps within one revolution	-	Steps
<a href="#">C02763</a>	Encoder rev: Number of revolutions	-	Rev.
Greyed out = display parameter			



# 6 Encoder evaluation

## 6.3 Parameter setting

---

Parameters	Info	Lenze setting	
		Value	Unit
<a href="#">C02764</a>	Encoder speed	-	rpm
<a href="#">C02765</a>	Encoder error	-	
Greyed out = display parameter			

### 6.3.11 Resolver error compensation

This function extension is available from software version V7.0!

Resolver errors typically occur in form of the 1st and 2nd harmonic. They have two different causes:

1. The inductances of the sine and cosine track of the resolver have slightly different values.
2. Sine and cosine track do not magnetise orthogonally to each other.

Resolver errors due to cause 1 can be corrected by adjusting the gains of the digital/analog converters which feed the resolver tracks. In the Lenze setting, the gains of both resolver tracks are preset with identical values.

Resolver errors due to cause 2 can be compensated for by a slight correction of the angle via which both resolver tracks are fed relative to one another.

By executing the device command [C00002](#) = "59: Resolver error identification", the gain of the digital/analog converter for feeding the resolver and the angle which serves to feed the two resolver tracks relatively to each other are corrected so that the resolver error is minimised.

- A precondition for the execution of the device command is that the machine is in speed-controlled operation (servo control). The speed amount during the identification must be constant and higher than 500 rpm.
- After the resolver error identification has been executed successfully, the resolver error compensation is activated automatically ([C00418](#) = "1: Activated"). Now the resolver operates with the following resolver error parameters which have been identified during the procedure:

Parameters	Info	Lenze setting	
		Value	Unit
<a href="#">C02862/1</a>	Resolver: cos gain	100	%
<a href="#">C02862/1</a>	Resolver: sine gain	100	%
<a href="#">C02863</a>	Resolver: Angle correction	0	

- The detected gain can take values between 0 ...100 %.
  - With a setting of 0 %, the gain of the corresponding resolver track is only 95 % of the default setting.
  - With a sensible resolver error compensation only one of the two gains is adapted. The other remains at 100 %.
- For a permanent acceptance of the identified resolver error parameters, the parameter set must be saved ([C00002](#) = "11: Save start parameters").
- When the resolver error compensation is deactivated ([C00418](#) = "0: Deactivated"), the resolver operates with the Lenze setting again. The identified resolver error parameters remain stored.

The resolver error identification can fail due to the following:

- Wrong control mode is active (no servo control)
- Error or fault is active
- Another identification is active
- The speed is too low (< 500 rpm)
- Time-out while the algorithm is processed

### 6.3.12 Encoder angular drift monitoring

The optional encoder angular drift monitoring monitors a potential deviation between the actual encoder angle and the angle calculated by the counting of increments in the encoder evaluation.



The encoder angular drift monitoring is activated by parameterising an error response that is not "0: No response" in [C00621](#).

If a deviation higher than 45° (electrical) is recognised when monitoring is activated:

- The error message "Encoder monitoring: pulse deviation detected" is entered in the logbook of the controller.
- The error response parameterised in [C00621](#) is triggered.
- The "Reference known" status of the "Homing" basic drive function is reset (if this status was set before)



#### Tip!

A deviation may occur, for instance, by incorrect parameter setting of the encoder increments, by lines in the form of interferences caused by EMC or loss of lines caused by EMC.

The encoder angular drift monitoring for encoders with and without absolute information is implemented by two different principles which are explained in detail in the following subchapters.

#### 6.3.12.1 Angular drift monitoring for encoders without absolute information

When an encoder without absolute information is used, the number of increments between two zero pulses (one revolution) is monitored. This value must equal the encoder increments set in [C00420](#).



#### Note!

After mains switching, monitoring is only active after second incoming zero pulse since the first line difference to be used can only be calculated with the second and first zero pulse.

When the motor (and thus the encoder) is replaced, it is very likely that a angular drift error occurs within the first revolution after acknowledging the encoder error since the monitoring function cannot recognise that the encoder has been replaced.

---

### 6.3.12.2 Angular drift monitoring for encoders with absolute information

For an encoder with absolute information, cyclical communication with the encoder takes place and the angle is read out digitally. This angle is compared to the angle from the encoder evaluation.



#### Note!

If monitoring is deactivated ([C00621](#) = "0: No response"), there is no cyclic communication with the encoder, and therefore no communication errors with the encoder can occur.

If monitoring is activated, it is only executed for speeds lower than 100 rpm due to runtimes for communication.

- If increments get lost at higher speeds, this deviation can only be recognised when the speed falls below 100 rpm for at least 80 ms.

After each detected encoder angular drift error, a renewed read-out of the position is tripped automatically and this angle is written into the encoder evaluation. This makes it possible to acknowledge the error. In case of synchronous machines, the pole position is corrected simultaneously.

## 7 Braking operation

The 9400 HighLine controller as single-axis controller (single drive) is provided with an integrated brake transistor.

- The required brake resistor must be connected externally (see Mounting Instructions/Hardware Manual).
- The rated values for the internal brake transistor are given in the Hardware Manual in the chapter "Rated data".



### Stop!

If the brake resistor actually connected is smaller than the brake transistor parameterised, the brake chopper can be destroyed!

The brake resistor can be thermally overloaded. Carry out protective measures suitable for the installation, e.g.:

- Parameterisation of an error response in [C00574](#) and evaluation of the parameterised error message within the application or within the machine control. ▶ [I2t utilisation - brake resistor](#) (p. 273)
- External interconnection using the thermal contact on the brake resistor (e.g. supply interruption via the mains contactor and activation of the mechanical brakes).



### Note!

The brake chopper control is also guaranteed if, for example, the application stands still or the 24-V supply is not connected and the controller is only fed by the DC bus.

# 7 Braking operation

## 7.1 Parameter setting

### 7.1 Parameter setting

#### Short overview: Parameters for braking operation

Parameters	Info	Lenze setting	
		Value	Unit
<a href="#">C00129</a>	Brake resistance value	180.0	Ohm
<a href="#">C00130</a>	Rated brake resistor power	5600	W
<a href="#">C00131</a>	Thermal capacity - brake resistor	485	kWs
<a href="#">C00133</a>	Ref.: Brake chopper utilisation	Minimum resistance (C00134)	
<a href="#">C00134</a>	Min. brake resistance	-	Ohm
<a href="#">C00137</a>	Brake transistor utilisation	-	%
<a href="#">C00138</a>	Brake resistor utilisation	-	%
<a href="#">C00173</a>	Mains voltage	400/415 V	
<a href="#">C00181</a>	Reduced brake chopper threshold	0	V
<a href="#">C00569</a>	Resp. brake trans. ixt > C00570	Warning	
<a href="#">C00570</a>	Warning thres. brake transistor	90	%
<a href="#">C00571</a>	Resp. brake res. i2t > C00572	Warning	
<a href="#">C00572</a>	Warning thres. brake resistor	90	%
<a href="#">C00573</a>	Resp. to brake transistor overload	No response	
<a href="#">C00574</a>	Resp. to brake resist. overtemp.	No response	
<a href="#">C00600</a>	Resp. to DC bus overvoltage	Fault	

Greyed out = display parameter

#### 7.1.1 Setting the voltage threshold for braking operation

The voltage threshold for braking operation is set via [C00173](#) (mains voltage) and [C00181](#) (reduced brake chopper threshold). If the brake chopper threshold in the DC bus is exceeded, the brake transistor is switched on.

Mains voltage selected in C00173	Effective brake chopper threshold
230 V	390 V - value in <a href="#">C00181</a> (0 ... 100 V)
400/415 V	725 V - value in <a href="#">C00181</a> (0 ... 100 V)
460/480 V	765 V - value in <a href="#">C00181</a> (0 ... 100 V)
500 V	790 V - value in <a href="#">C00181</a> (0 ... 100 V)

# 7 Braking operation

## 7.2 Monitoring

---

### 7.2 Monitoring

#### 7.2.1 Overcurrent protection

The brake chopper hardware is monitored with regard to overcurrent (short circuit or earth fault).



#### Note!

The monitoring with regard to overcurrent can only be triggered if a braking current is actually available. It is not possible to carry out a test in idle state (without connected brake resistor).

- If monitoring responds:
  - The brake chopper is switched off immediately.
  - The "Fault" response is activated.
  - The "Brake transistor: overcurrent" error message is entered into the logbook of the controller.



#### Note!

The error can only be acknowledged after 2 seconds at the earliest to resume the braking operation.



#### Tip!

In addition to the overcurrent protection the controller is provided with two further monitoring functions for the braking operation, which are also activated if no brake resistor is connected at all (testing mode for checking the parameterisation):

▶ [Ixt utilisation - brake transistor](#) (📖 272)

▶ [I2t utilisation - brake resistor](#) (📖 273)

### 7.2.2 Ixt utilisation - brake transistor

The controller is provided with a monitoring function for the Ixt utilisation of the internal brake transistor.



#### Note!

The braking operation will never be switched off by this monitoring function.

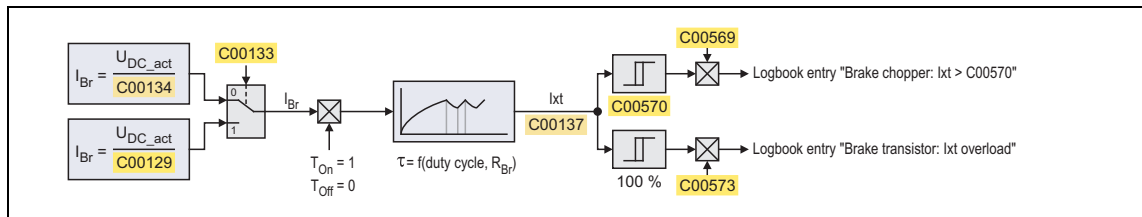

[7-1] Signal flow of Ixt utilisation - brake chopper

- Monitoring is based on a mathematical model which calculates the braking current from the current DC-bus voltage and the brake resistance parameterised.
  - Hence, monitoring can be activated although no brake resistor is connected and can therefore also be used for a testing mode to check the parameterisation.
- During the calculation the thermal utilisation of the brake transistor is taken into consideration by the use of an accordingly adapted time constant.
- In [C00133](#) it can be selected whether the minimum brake resistance (display in [C00134](#)) which depends on the network setting in [C00173](#)) or the brake resistor value parameterised in [C00129](#) is to be used as a reference for calculating the utilisation.
- [C00137](#) displays the calculated utilisation of the brake transistor in [%].
  - A 100 % utilisation corresponds to the continuous braking power which is provided by the integrated brake chopper at a DC-bus voltage of 790 V (or 390 V at a mains voltage of 230 V).
  - The maximum braking power (assuming that the utilisation starts at 0 %) can be provided for a time period depending on the device.
  - The calculated utilisation is provided as oscilloscope signal *Common.dnIxtBrakeChopper* to check the braking operation while the system is running (scaling:  $2^{30} \equiv 100\%$ ).
- If the utilisation exceeds the advance warning threshold set in [C00570](#), "Brake chopper: Ixt > C00570" is entered in the logbook and the response set in [C00569](#) (default setting: "Warning") is activated.
- When the utilisation reaches the limit value (100 %):
  - The activation of the brake chopper is reset to the permanently permissible mark-to-space ratio (taking the parameterised brake resistance into consideration). (The brake chopper is activated with 4 kHz, which means that it can be switched on/off at minimum intervals of 250  $\mu$ s.)
  - The response set in [C00573](#) (default setting: "No response") is activated with the corresponding effects on the state machine and the inverter.



**Note!**

If the DC-bus voltage exceeds the overvoltage threshold due to a too high braking energy, the monitoring function for overvoltage in the DC bus responds. ▶ [Overvoltage in the DC bus](#) (□ 275)

**7.2.3 I<sup>2</sup>t utilisation - brake resistor**

The controller is provided with a monitoring function of the I<sup>2</sup>t utilisation of the brake resistor which is proportional to the converted braking power.

**Note!**

The braking operation will never be switched off by this monitoring function.

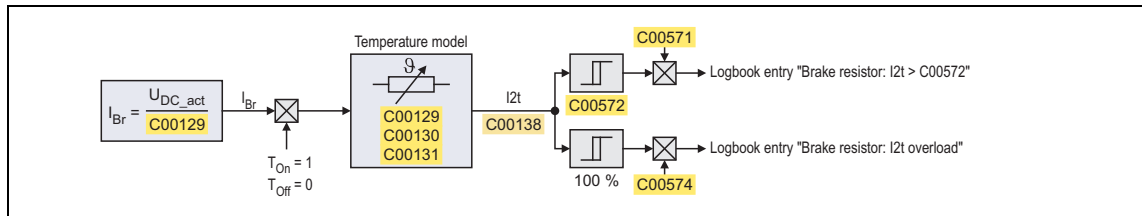

[7-2] Signal flow - I<sup>2</sup>t utilisation - brake resistor

- The monitoring function is based on the mathematical model which calculates the braking current from the current DC-bus voltage and the brake resistance parameterised in [C00129](#).
  - Hence, monitoring can be activated although no brake resistor is connected and can therefore also be used for a testing mode to check the parameterisation.
- The calculation considers the thermal utilisation of the brake resistor based on the following parameters:
  - Resistance value ([C00129](#))
  - Continuous power ([C00130](#))
  - Thermal capacity ([C00131](#))
- [C00138](#) displays the calculated utilisation of the brake resistor in [%].
  - A 100 % utilisation corresponds to the continuous power of the brake resistor which results at the maximum permissible temperature limit of the brake resistor.
  - The calculated utilisation is provided as oscilloscope signal *Common.dnI2tBrakeResistor* to check the braking operation while the system is running (scaling:  $2^{30} \equiv 100\%$ ).
- If the utilisation exceeds the advance warning threshold set in [C00572](#), "Brake resistor: I2t > C00572" is entered in the logbook and the response set in [C00571](#) (default setting: "Warning") is activated.

- 
- When the utilisation reaches the limit value (100 %):
    - The response set in [C00574](#) (default setting: "No response") is activated with the corresponding effects on the state machine and the inverter.
    - **Only applies to software versions lower than V3.0:**

The activation of the brake chopper is reset to the permanently permissible mark-to space ratio (taking the parameterised brake resistance into consideration). (The brake chopper is activated with 4 kHz, which means that it can be switched on/off at minimum intervals of 250 µs.)



### Stop!

The brake resistor can be thermally overloaded. Carry out protective measures suitable for the installation, e.g.:

- Parameterisation of an error response in [C00574](#) and evaluation of the parameterised error message within the application or within the machine control system.
- External interconnection using the thermal contact on the brake resistor (e.g. supply interruption via the mains contactor and activation of the mechanical brakes).



### Note!

If the system is dimensioned correctly, this monitoring function should not respond. If individual rated data of the actually connected brake resistor are not known, they have to be determined "empirically".

### 7.2.4 Overvoltage in the DC bus

If, due to a too high braking energy, the DC-bus voltage exceeds the overvoltage threshold which results from the mains voltage setting in [C00173](#), the "Overvoltage in the DC bus" error message is output and the response set in [C00600](#) is activated (default setting: "Trouble").



#### Note!

For hoist applications, the "Fault" response should be selected in [C00600](#) (in combination with an emergency stop via mechanical brakes).

# 8 I/O terminals

## 8.1 Overview

# 8 I/O terminals

This chapter provides information about options for parameter setting and configuration of the controller input and output terminals.



**Tip!**

Information on wiring the terminals can be found in the Mounting Instructions for the controller!

## 8.1 Overview

Front view	Terminal assignment	Info
	<b>X2</b>	<ul style="list-style-type: none"> <li>▶ <a href="#">"State bus" monitoring function</a> (☰ 286)</li> </ul>
	<b>X3</b>	<ul style="list-style-type: none"> <li>▶ <a href="#">Analog inputs</a> (☰ 277)</li> <li>▶ <a href="#">Analog outputs</a> (☰ 280)</li> </ul>
	<b>X4</b>	<ul style="list-style-type: none"> <li>▶ <a href="#">Digital outputs</a> (☰ 284)</li> </ul>
	<b>X5</b>	<ul style="list-style-type: none"> <li>▶ <a href="#">Digital inputs</a> (☰ 282)</li> <li>▶ <a href="#">Touch probe detection</a> (☰ 288)</li> </ul>

# 8 I/O terminals

## 8.2 Analog inputs

### 8.2 Analog inputs

The controller has two analog inputs that can be used to detect differential voltage signals in the range of  $\pm 10$  V, e.g. analog speed setpoint selections or the voltage signals of an external sensor (temperature, pressure, etc.).

- Optionally, analog input 1 can also be used to detect current setpoints.

#### 8.2.1 Terminal assignment/electrical data

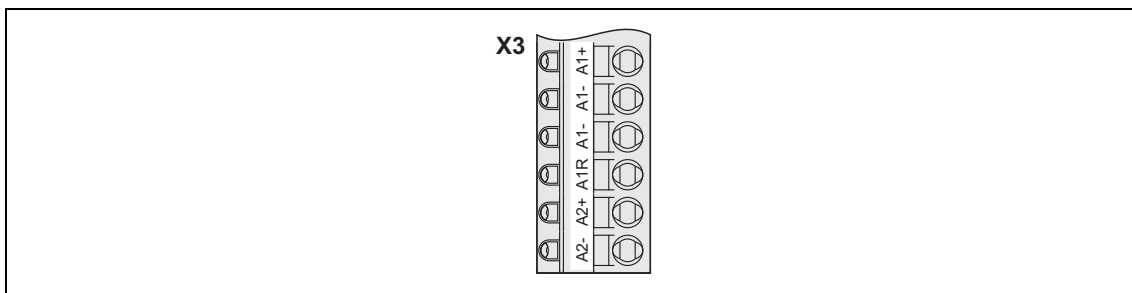

Terminal	Use	Electrical data
X3/A1- X3/A1+	Differential voltage input 1 (no jumper between A1R and A1-)	Level: -10 V ... +10 V
		Resolution: 11 bits + sign
		Scaling: If <a href="#">C00034</a> = "0": $\pm 10$ V $\equiv \pm 2^{30}$
		Conversion rate: 1 kHz
	Current input (jumper between A1R and A1-)	Level: -20 mA ... +20 mA
		Resolution: 10 bits + sign
X3/A2- X3/A2+	Differential voltage input 2	Level: -10 V ... +10 V
		Resolution: 11 bits + sign
		Scaling: $\pm 10$ V $\equiv \pm 2^{30}$
		Conversion rate: 1 kHz

### 8.2.2 Parameter setting

Short overview of parameters for the analog inputs:

Parameters	Info
<a href="#">C00034</a>	Config. analog input 1
<a href="#">C00598</a>	Resp. to open circuit AIN1
<a href="#">C02730/1</a>	Analog input 1: Gain
<a href="#">C02730/2</a>	Analog input 2: Gain
<a href="#">C02731/1</a>	Analog input 1: Offset
<a href="#">C02731/2</a>	Analog input 2: Offset
<a href="#">C02732/1</a>	Analog input 1: Dead band
<a href="#">C02732/2</a>	Analog input 2: Dead band
<a href="#">C02800/1</a>	Analog input 1: Input signal (-16384 ≙ -100 %, 16383 ≙ 100 %)
<a href="#">C02800/2</a>	Analog input 2: Input signal (-16384 ≙ -100 %, 16383 ≙ 100 %)

Greyed out = display parameter

### 8.2.3 Reconfiguring analog input 1 into current input

By means of the following two steps, analog input 1 can be reconfigured into a current input:

1. Bridge the terminals A1R and A1- at terminal strip X3 by means of wiring.
2. Select the corresponding current loop under [C00034](#).



**Tip!**

Like this you can implement a 4 ...20 mA current loop, e.g. for speed setpoint selection.

#### Open-circuit monitoring

Under [C00598](#) you can set an error response to open circuit for the 4 ...20 mA current loop.

# 8 I/O terminals

## 8.2 Analog inputs

### 8.2.4 "LS\_AnalogInput" system block

The LS\_AnalogInput system block displays the analog inputs in the function block editor.

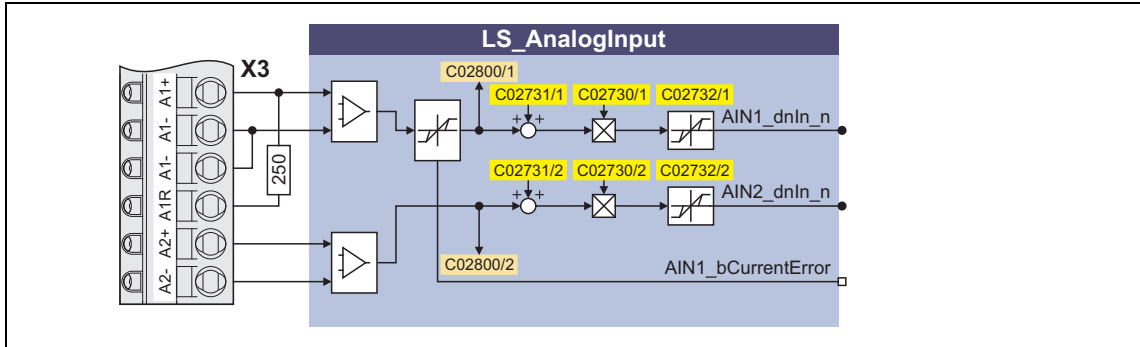

Output	Data type	Value/meaning
AIN1_dnIn_n	DINT	Analog input 1 <ul style="list-style-type: none"> <li>Scaling: <ul style="list-style-type: none"> <li><math>\pm 2^{30} \equiv \pm 10 \text{ V}</math> for use as a voltage input</li> <li><math>\pm 2^{30} \equiv \pm 20 \text{ mA}</math> for use as a current input</li> </ul> </li> </ul>
AIN2_dnIn_n	DINT	Analog input 2 <ul style="list-style-type: none"> <li>Scaling: <math>\pm 2^{30} \equiv \pm 10 \text{ V}</math></li> </ul>
AIN1_bCurrentError	BOOL	Status signal "Current input error" <ul style="list-style-type: none"> <li>Only when analog input 1 is used as current input.</li> <li>Application: Cable-breakage monitoring of the 4 ...20 mA circuit.</li> </ul>
		TRUE   $ I_{AIN1}  < 2 \text{ mA}$

### 8.3 Analog outputs

The controller has two analog outputs that can be used to output internal analog signals as voltage signals, e.g. for the control of analog indicating instruments or as a setpoint for slave drives.



#### Note!

Initialisation behaviour:

- After mains switching until the application is started, the analog outputs remain on 0 V.

Exception handling:

- In the case of a critical exception within the application (e. g. reset), the analog outputs are set to 0 V.

#### 8.3.1 Terminal assignment/electrical data

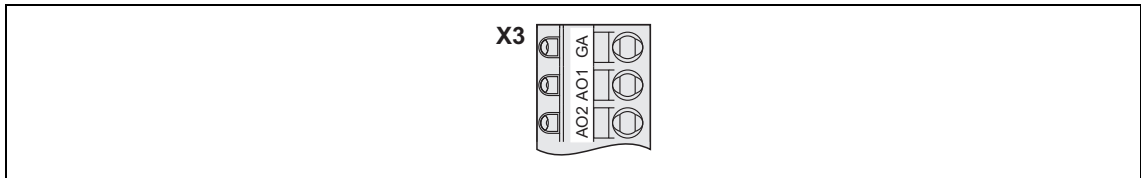

Terminal	Use	Electrical data	
X3/AO1	Voltage output 1	Level:	-10 V ... +10 V (max. 2 mA)
		Resolution:	11 bits + sign
		Scaling:	$\pm 2^{30} \equiv \pm 10$ V
		Conversion rate:	1 kHz
X3/AO2	Voltage output 2	Level:	-10 V ... +10 V (max. 2 mA)
		Resolution:	11 bits + sign
		Scaling:	$\pm 2^{30} \equiv \pm 10$ V
		Conversion rate:	1 kHz
X3/GA	Reference potential (analog ground)		



# 8 I/O terminals

## 8.3 Analog outputs

### 8.3.2 Parameter setting

Short overview of parameters for the analog outputs:

Parameters	Info
<a href="#">C02733/1</a>	Analog output 1: Gain
<a href="#">C02733/2</a>	Analog output 2: Gain
<a href="#">C02734/1</a>	Analog output 1: Offset
<a href="#">C02734/2</a>	Analog output 2: Offset
<a href="#">C02801/1</a>	Analog output 1: Output signal
<a href="#">C02801/2</a>	Analog output 2: Output signal
Greyed out = display parameter	

### 8.3.3 "LS\_AnalogOutput" system block

In the function block editor the **LS\_AnalogOutput** system block provides the interface to the analog outputs.

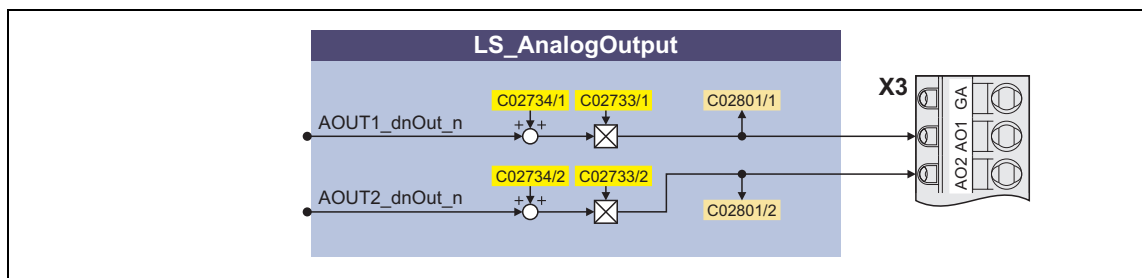

Input	Data type	Information/possible settings
AOUT1_dnOut_n	DINT	Analog output 1 • Scaling: $\pm 2^{30} \equiv \pm 10 \text{ V}$
AOUT2_dnOut_n	DINT	Analog output 2 • Scaling: $\pm 2^{30} \equiv \pm 10 \text{ V}$

# 8 I/O terminals

## 8.4 Digital inputs

### 8.4 Digital inputs

The controller is provided with eight freely configurable digital inputs.

- All digital inputs can be used for touch probe. ▶ [Touch probe detection](#) (📖 288)
- The control input RFR of terminal strip X5 for controller enable is fixedly connected to the device control.

#### 8.4.1 Terminal assignment/electrical data

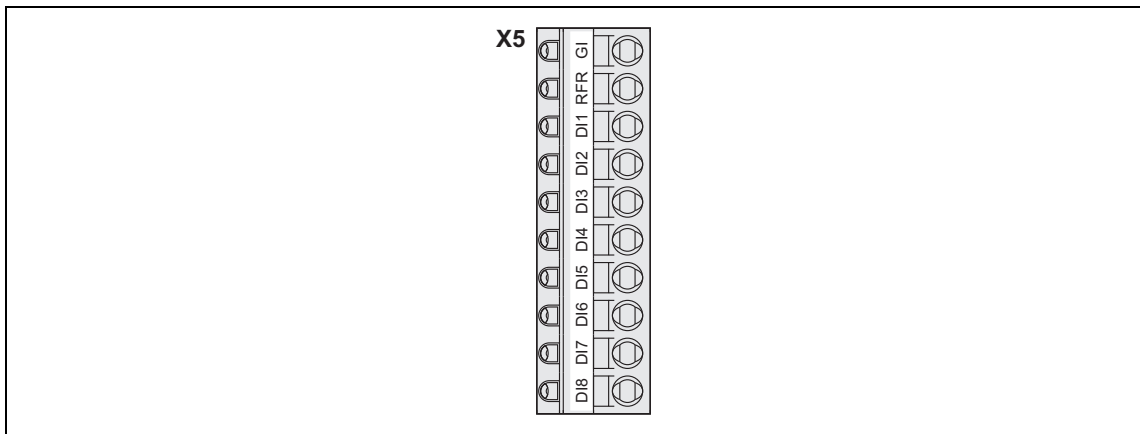

Terminal	Use	Electrical data
X5/D11 X5/D18	Digital input 1 ... 8	LOW level: 0 ... +5 V
		HIGH level: +15 ... +30 V
		Input current: 8 mA per input (at 24 V)
		Electric strength of external voltage: Max. ±30 V
		Conversion rate: 1 kHz
X5/RFR	Controller enable	See digital inputs
X5/GI	Reference potential (digital ground)	

#### 8.4.2 Parameter setting

Short overview of parameters for the digital inputs:

Parameters	Info
<a href="#">C00114</a>	Digital input x - terminal pol.
<a href="#">C00443</a>	Status: Digital inputs
<a href="#">C02803</a>	Status word: Digital inputs
<a href="#">C02830</a>	Digital inputs: Delay time

Greyed out = display parameter

8.4.3 "LS\_DigitalInput" system block

The LS\_DigitalInput system block displays the digital inputs and the status of the state bus in the function block editor.

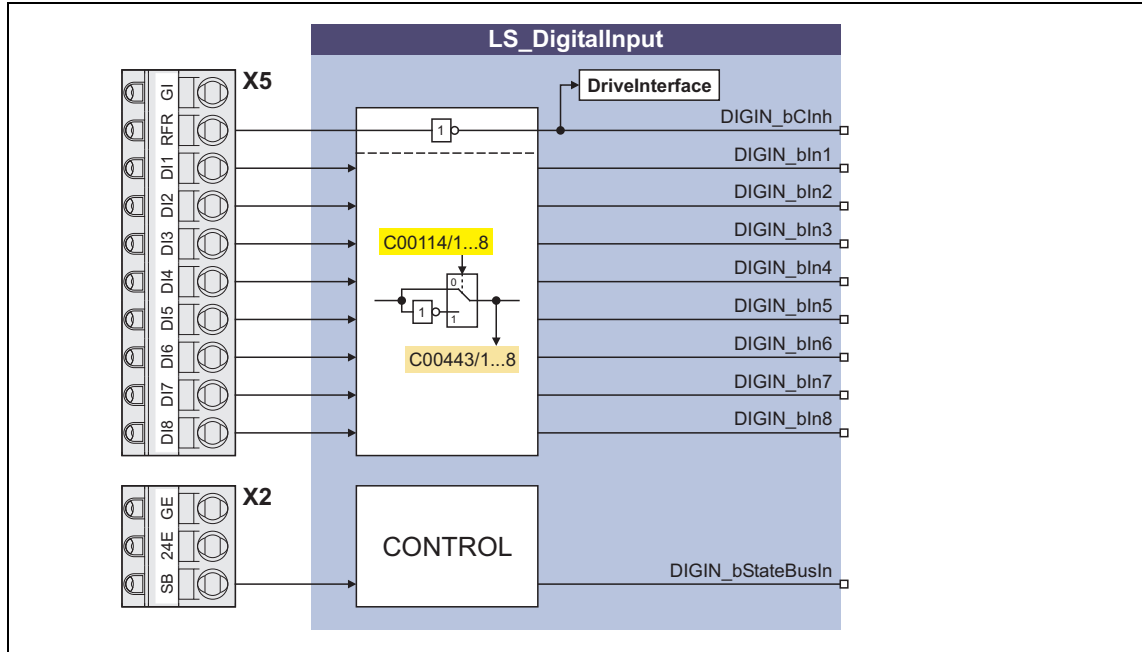

Output	Value/meaning
DIGIN_bCInh <small>C00443/9   BOOL</small>	Status signal "Controller inhibit" <ul style="list-style-type: none"> <li>The control input RFR (X5/pin 9) for setting/deactivating controller inhibit is fixedly connected to the device control (DCTRL) via an inverter.</li> </ul>
DIGIN_bIn1 ... DIGIN_bIn8 <small>C00443/1   BOOL</small> <small>C00443/8   BOOL</small>	Digital input 1 ... 8
DIGIN_bStateBusIn <small>C00443/12   BOOL</small>	State bus status ▶ "State bus" monitoring function (📖 286)
	TRUE A node connected to the state bus has set the state bus to LOW level and the "Error" state has been set. <ul style="list-style-type: none"> <li>The "Error" state is also set if a node connected to the state bus is not supplied with voltage.</li> </ul>

# 8 I/O terminals

## 8.5 Digital outputs

### 8.5 Digital outputs

The controller is provided with four freely configurable digital outputs.



#### Note!

Initialisation behaviour:

- After mains switching until the application is started, the digital outputs remain on FALSE.

Exception handling:

- In the case of a critical exception within the application (e. g. reset), the digital outputs are set to FALSE, taking the terminal polarity parameterised in [C00118](#) into consideration.

#### 8.5.1 Terminal assignment/electrical data

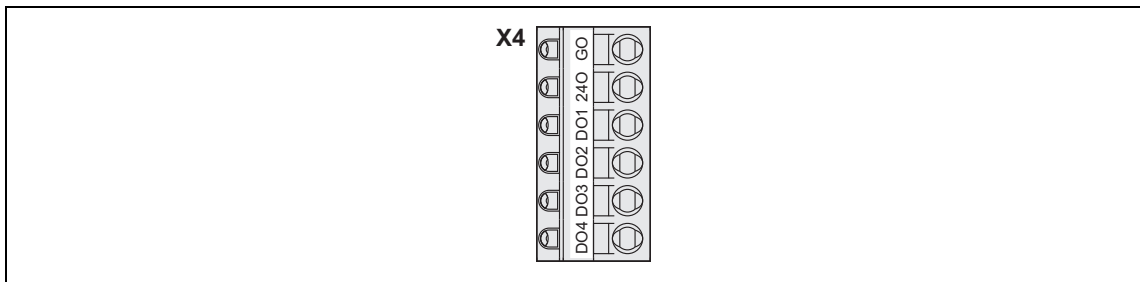

Terminal	Use	Electrical data	
X4/DO1 ... X4/DO4	Digital output 1 ... 4	LOW level:	0 ... +5 V
		HIGH level:	+15 ... +30 V
		Output current:	max. 50 mA per output (external resistance > 480 Ω at 24 V)
		Conversion rate:	1 kHz
X4/24V	External 24 V voltage supply for the digital outputs		
X4/GO	Reference potential (digital ground)		

#### 8.5.2 Parameter setting

Short overview of parameters for the digital outputs:

Parameters	Info
<a href="#">C00118</a>	Digital output x - terminal pol.
<a href="#">C00444</a>	Status: Digital outputs
<a href="#">C02802</a>	Status word: Digital outputs
Greyed out = display parameter	

# 8 I/O terminals

## 8.5 Digital outputs

### 8.5.3 "LS\_DigitalOutput" system block

In the function block editor the **LS\_DigitalOutput** system block provides the interface to the digital outputs, the state bus, and the yellow user LED at the front of the controller.

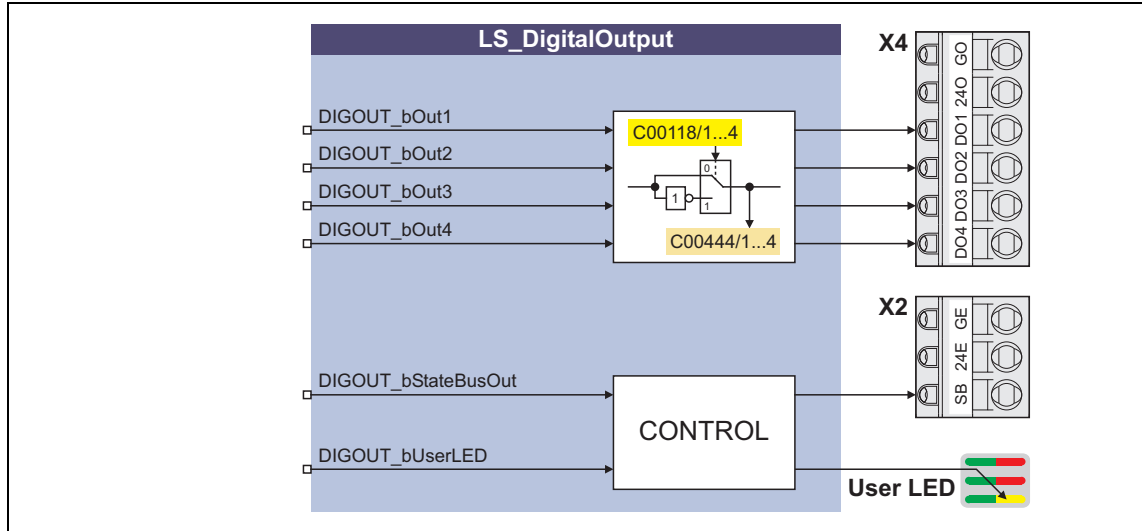

Input DIS code   data type	Information/possible settings
DIGOUT_bOut1 <a href="#">C00444/1</a>   BOOL ... DIGOUT_bOut4 <a href="#">C00444/4</a>   BOOL	Digital output 1 ... 4
DIGOUT_bStateBusOut <a href="#">C00444/18</a>   BOOL	Setting the state bus to the "Error" state ▶ <a href="#">"State bus" monitoring function (286)</a>
DIGOUT_bUserLED <a href="#">C00444/9</a>   BOOL	Control of yellow user LED on the front of the controller
	TRUE   LED on

## 8.6 "State bus" monitoring function

The state bus is a bus system that is solely designed for Lenze controllers, via which up to 20 controllers can be connected to each other, and by means of which the function of a "release cord" can be simulated:

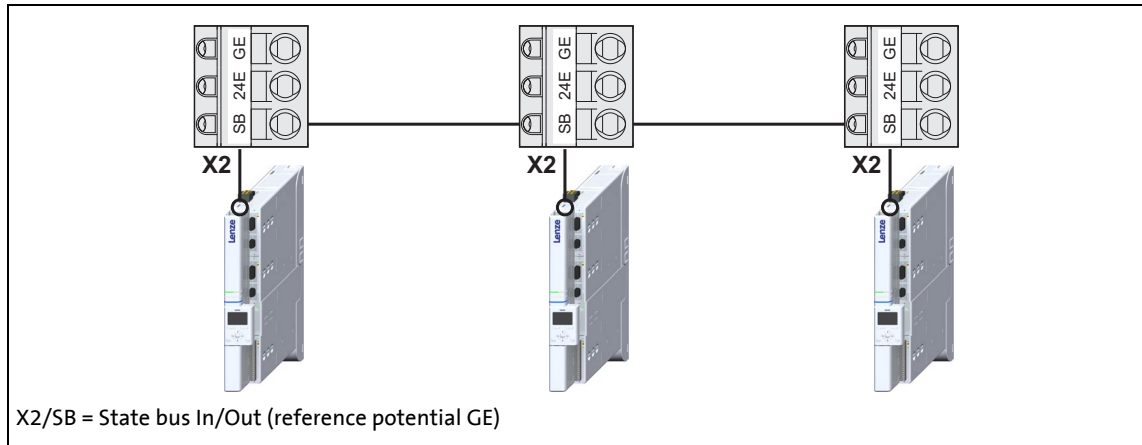

[8-1] Schematic diagram: Networking via state bus

- The state bus only knows the states "OK" and "Error".
- The state bus is a bus with multi-master capability, i.e. each node connected to the state bus can set the state bus to the "Error" state by setting it to LOW level.
- In the "Error" status, all nodes start their adjustable response, e.g. synchronised braking of the drive system.
- The "Error" state is also set if a node connected to the state bus is not supplied with voltage.



### Note!

Exception handling:

- In the case of a critical exception within the application (e. g. reset), the "release cord" is not triggered, the state bus remains in the "OK" status.

### 8.6.1 Detecting the current state

Via the output *DIGIN\_bStateBusIn* of the [LS\\_DigitalInput](#) system block, the current status of the state bus can be queried. In case of error the output *DIGIN\_bStateBusIn* is set to TRUE.

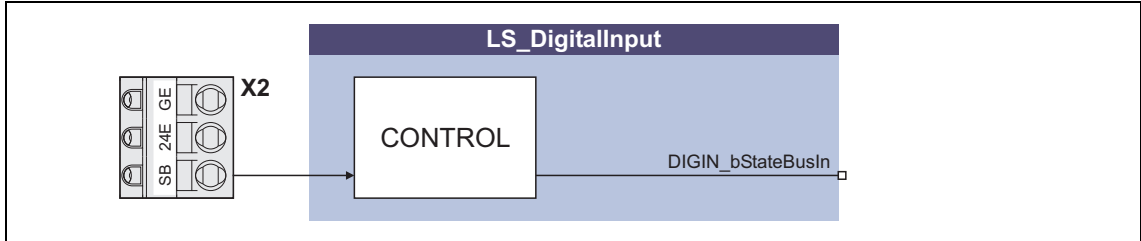

### 8.6.2 Setting the state bus to the "Error" state

If the input *DIGOUT\_bStateBusOut* of the [LS\\_DigitalOutput](#) system block is set to TRUE, the state bus is set to "Error" and all connected nodes start their pre-programmed response.

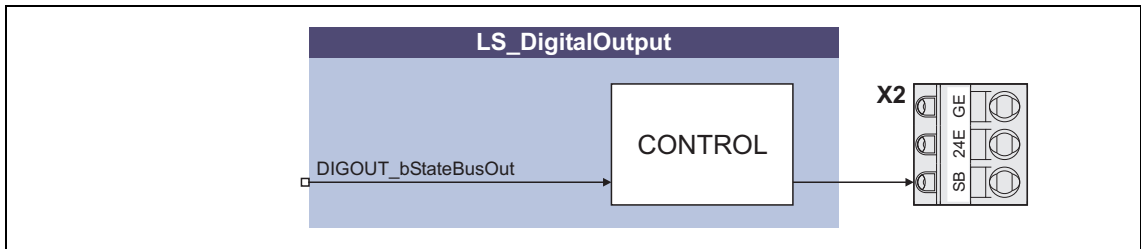

## 8.7 Touch probe detection

A "touch probe" is an event that, for instance, can be triggered edge-controlled via a digital input in order to detect a (quickly changing) actual value at the time of triggering and process it in the program.

### Overview of the touch probe channels

For the touch probe detection 12 touch probe channels are provided, which can be configured independently of each other:

Touch probe channel	Activating event	System block
1	Edge change at digital input 1	<a href="#">LS_TouchProbe1...8</a> (📖 291)
2	Edge change at digital input 2	
3	Edge change at digital input 3	
4	Edge change at digital input 4	
5	Edge change at digital input 5	
6	Edge change at digital input 6	
7	Edge change at digital input 7	
8	Edge change at digital input 8	
9	Motor encoder zero pulse	<a href="#">LS_TouchProbeMotor</a> (📖 292)
10	Position encoder zero pulse	<a href="#">LS_TouchProbeLoad</a> (📖 292)
11	DFIN zero pulse	LS_TouchProbeDFIN
12	DFOUT zero pulse	LS_TouchProbeDFOUT

- Each touch probe channel is assigned to a system block which provides the application with a scaled time stamp.
- The time stamp refers to the sampling time of the encoder signals and outputs the difference with regard to the touch probe event.

### Further processing of the touch probe

For further processing of the touch probe event the time stamp is to be transmitted to an instance of the **L\_SdTouchProbe** FB:

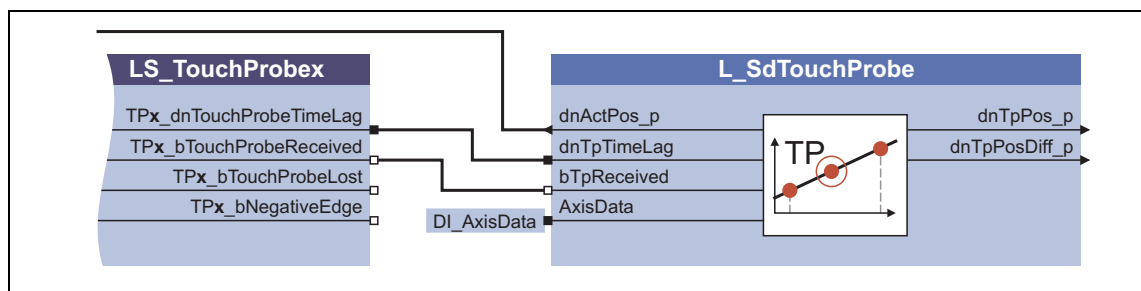

[8-2] Transfer of the time stamp to the L\_SdTouchProbe FB

- The **L\_SdTouchProbe** FB takes over the interpolation of the input signal on the basis of the time stamp and outputs the interpolated value and the difference to the last input signal.

### 8.7.1 Actual value interpolation (principle)

If a touch probe is detected, the (remaining) time until the following task cycle is determined and from this a time stamp is generated. On the basis of this time stamp, the **L\_SdTouchProbe** FB can



then carry out a linear interpolation between the two actual position interpolation points; the result is the precise actual position at the time of the physical touch probe event.

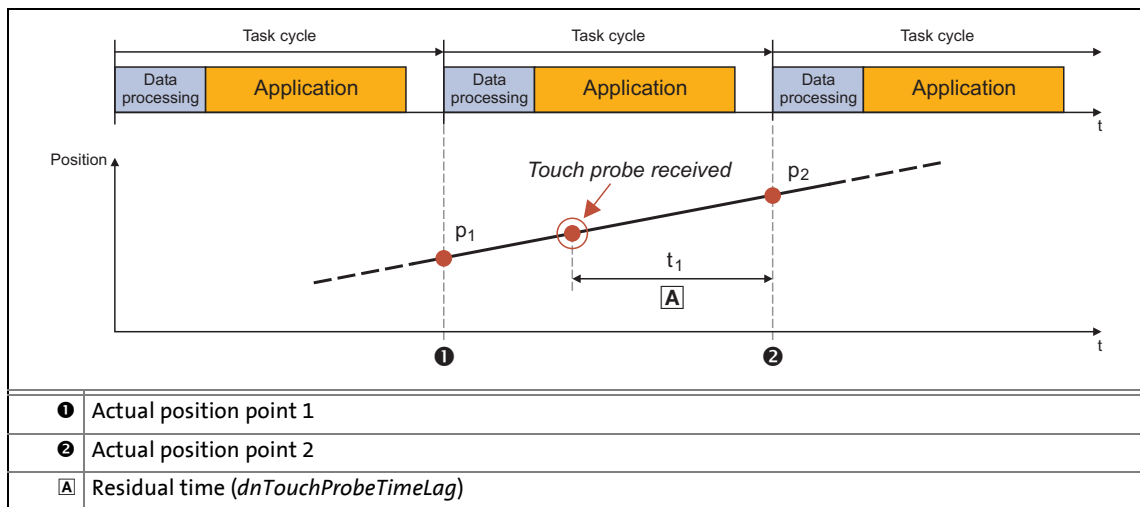

[8-3] Actual value determination through linear interpolation (principle)

### 8.7.2 Dead time compensation

For dead time compensation during the detection of the touch probe event, it is possible to select a delay time (*Touch probe delay*) in [C02810](#) for each touch probe channel, which will be considered in the touch probe calculation.

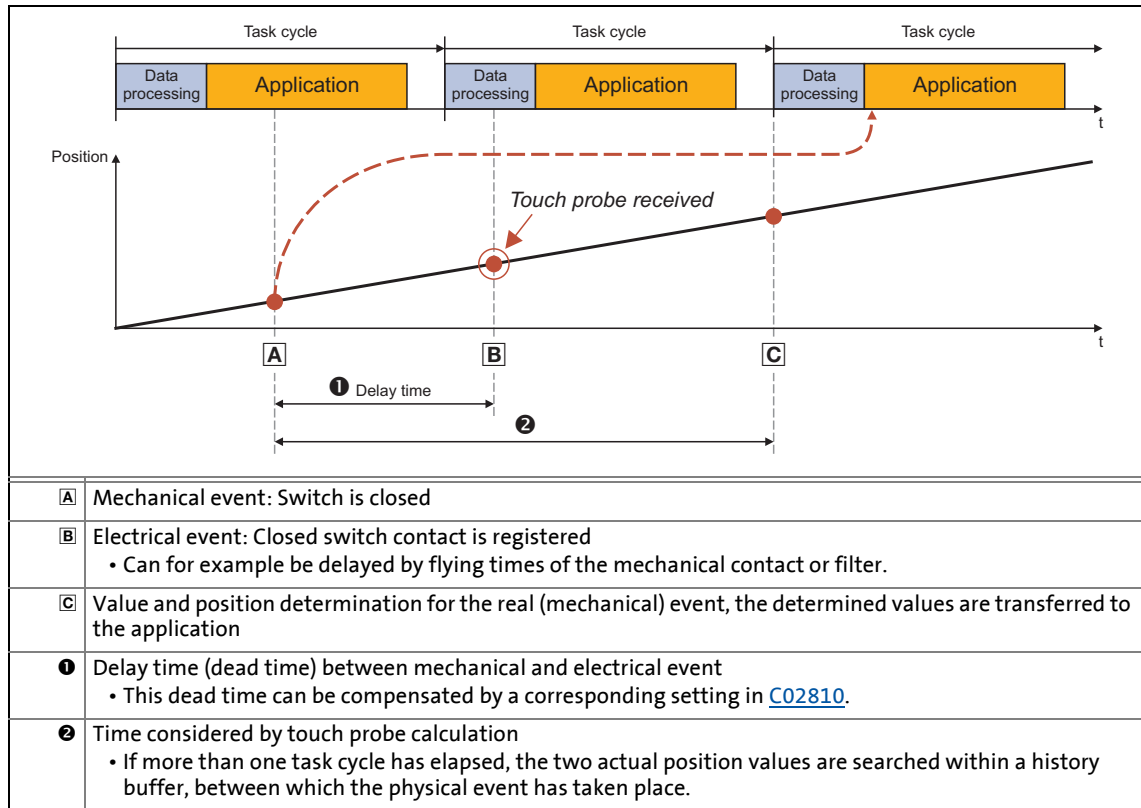

[8-4] Dead time compensation (principle)

- The filtering of the digital inputs has an impact on the electrical detection of the touch probe, i. e. the delay time for the digital inputs set in [C02830](#) has to be taken into consideration within the delay time [C02810](#).
- For the optional digital frequency input/output the setting of the delay times is effected via separate parameters:
  - C13021 or C14021: TP delay time - digital frequency input.
  - C13061 or C14061: TP delay time - digital frequency output.

### 8.7.3 "LS\_TouchProbe1...8" system block

In the function block editor the **LS\_TouchProbe1 ... LS\_TouchProbe8** system blocks display the touch probe channels 1 ... 8 which are assigned to the digital inputs **DI1 ... DI8**.

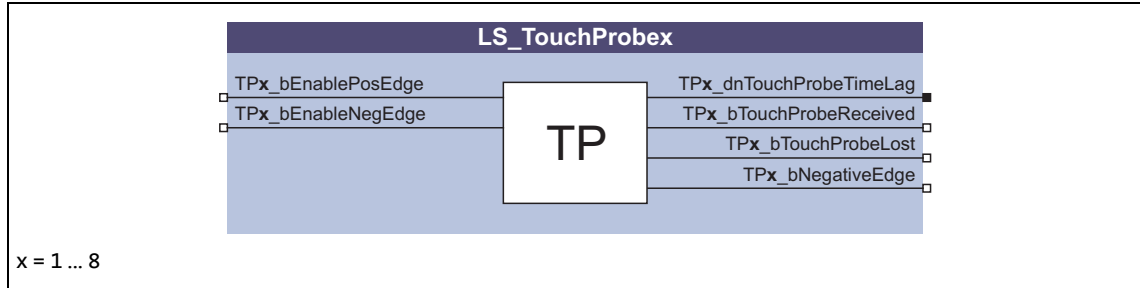

Input	Data type	Value/meaning
TPx_bEnablePosEdge	BOOL	Enable response to positive edge <b>Note:</b> <ul style="list-style-type: none"> <li>If several positive edges occur within the basic cycle time (HighLine: 1 ms), only the first positive edge initiates the touch probe event and no status signal "touch probe(s) lost" is generated.</li> </ul>
		TRUE   A touch probe event is activated by a positive edge at the digital input DIx.
TPx_bEnableNegEdge	BOOL	Enable response to negative edge <b>Note:</b> <ul style="list-style-type: none"> <li>If several negative edges occur within the basic cycle time (HighLine: 1 ms), only the first negative edge initiates the touch probe event.</li> <li>If a positive and negative edge occur within the basic cycle time (1 ms), and if the response to both edges is enabled, only the positive edge initiates the touch probe event.</li> <li>In both cases no status signal "touch probe(s) lost" is generated.</li> </ul>
		TRUE   A touch probe event is activated by a negative edge at the digital input DIx.

Output	Data type	Value/meaning
TPx_dnTouchProbeTimeLag	DINT	Scaled time stamp for further processing of the touch probe event with the <b>L_SdTouchProbe</b> FB. <ul style="list-style-type: none"> <li>1 ms <math>\equiv</math> 20 bits</li> </ul>
TPx_bTouchProbeReceived	BOOL	Status signal "Touch probe detected" <ul style="list-style-type: none"> <li>State is only set for one task cycle.</li> </ul>
		TRUE   Touch probe event has been activated.
TPx_bTouchProbeLost	BOOL	Status signal "Touch probe(s) lost" <ul style="list-style-type: none"> <li>State is only set for one task cycle.</li> </ul>
		TRUE   More than one touch probe event was actuated within the task runtime. The time stamp that is output only refers to the first touch probe event.
TPx_bNegativeEdge	BOOL	Status signal "Negative edge detected" <ul style="list-style-type: none"> <li>State is only set for one task cycle.</li> </ul>
		TRUE   A negative edge has been detected at the digital input DIx.

### 8.7.4 "LS\_TouchProbeMotor" system block

In the function block editor the **LS\_TouchProbeMotor** system block represents the touch probe channel that is assigned to the motor encoder zero pulse.

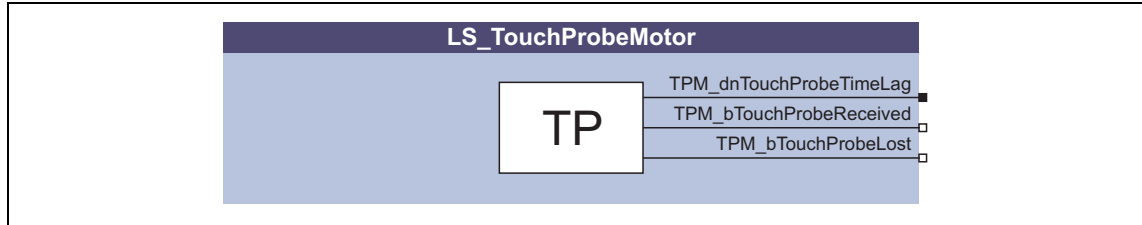

Output	Data type	Value/meaning
TPM_dnTouchProbeTimeLag	DINT	Scaled time stamp for further processing of the touch probe event with the <b>L_SdTouchProbe</b> FB.
TPM_bTouchProbeReceived	BOOL	Status signal "Touch probe detected" • State is only set for one task cycle.
		TRUE   Touch probe event has been activated.
TPM_bTouchProbeLost	BOOL	Status signal "Touch probe(s) lost" • State is only set for one task cycle.
		TRUE   More than one touch probe event was actuated within the task runtime and therefore could not be detected anymore.

### 8.7.5 "LS\_TouchProbeLoad" system block

In the function block editor the **LS\_TouchProbeLoad** system block represents the touch probe channel that is assigned to the position encoder zero pulse.

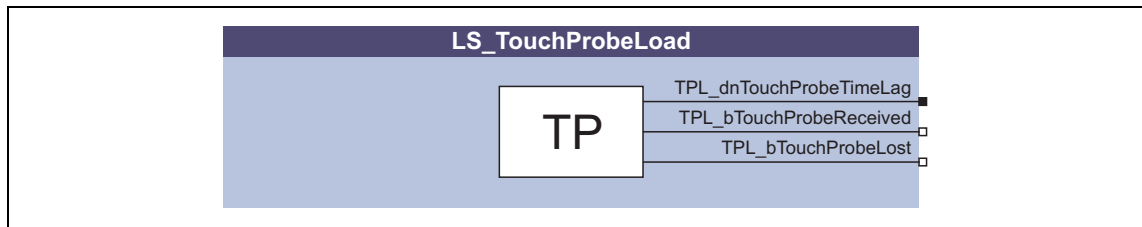

Output	Data type	Value/meaning
TPL_dnTouchProbeTimeLag	DINT	Scaled time stamp for further processing of the touch probe event with the <b>L_SdTouchProbe</b> FB.
TPL_bTouchProbeReceived	BOOL	Status signal "Touch probe detected" • State is only set for one task cycle.
		TRUE   Touch probe event has been activated.
TPL_bTouchProbeLost	BOOL	Status signal "Touch probe(s) lost" • State is only set for one task cycle.
		TRUE   More than one touch probe event was actuated within the task runtime and therefore could not be detected anymore.

## 8.8 Configure exception handling of the outputs

From »Engineer« version 2.10 onwards, the function block editor for the controller can also be used to configure the behaviour of the analog and digital outputs and that of the brake control and the output ports after a task overflow in order to adapt it to the respective application.



### How to configure the exception handling:

1. Go to the *Project view* of the »Engineer« and select the 9400 HighLine controller.
2. Change to the **FB-Editor** tab in the *Workspace*.
3. Click on the  icon in the *FB editor toolbar* to open the *Configure exception handling* dialog box:

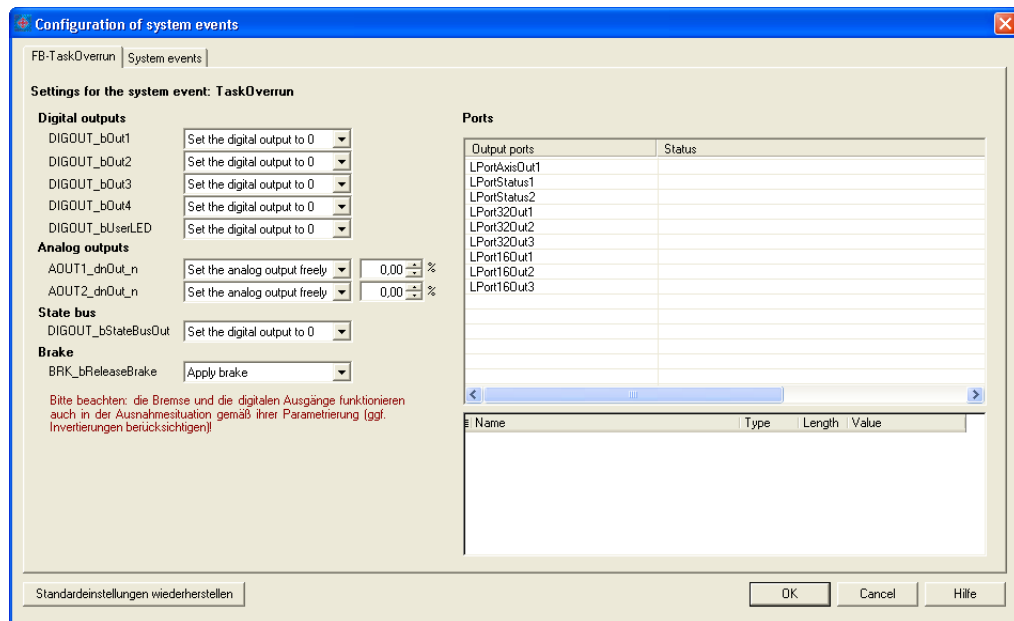

- On the **FB TaskOverrun** tab the behaviour of the controller outputs and that of the output ports defined in the application in the case of a task overflow can be configured.
  - On the **FB System Events** tab, the behaviour of the outputs of the drive controller and the application is only displayed and cannot be configured.
4. Carry out the desired configuration.
    - Each output can be configured individually. A free value can be set for the analog outputs (-200.00 ... 200.00 %).
    - If you select an output port in the "Ports" area on the right, all application variables for this output port are shown in the table below. In the "Value" column a value can be set for each application variable to which it is to be set if an event occurs can be specified.
    - If a value has been set for at least one application variable, the status "Exceptional behaviour parameterised" is shown for the corresponding output port.
    - If the **Restore standard settings** button is clicked, the default setting for task overflow is restored. In this case, all output terminals would be set to LOW level or 0 V in the event of a task overflow and the output ports would retain their last value.
  5. Click **OK** to accept the configuration and close the dialog box.

**Danger!**

In case a task overflow occurs, the brake can be configured to "open". This setting should be used with caution as the brake is then forcibly opened and does not close even if the drive controller is inhibited!

**Note!**

- To render the changes effective within the controller, the project has to be updated, and the changed application has to be transferred to the controller.
- During the reset or download of an application, all output signals are set to LOW level or 0 V for a short time (the state bus, in contrast, is set to HIGH level due to hardware inversion).

See also:

▶ [Behaviour after task overflow](#) (📖 109)

### 9 "CAN on board" system bus

The controller has an integrated CANopen system bus interface ("CAN on board") which is used to exchange i.a. process data and parameter values between the nodes. Furthermore, other modules can be connected via this interface such as decentralised terminals, operator and input devices (HMIs), as well as external controls and host systems.

The interface transfers CAN objects following the CANopen communication profile (CiA DS301, version 4.02) developed by the umbrella organisation of CiA (CAN in Automation) in conformity with the CAL (CAN Application Layer).



**Tip!**

- The parameters relevant for the CANopen system bus interface are assigned to different subcategories in the parameter list in »Engineer« and in the keypad in the **CAN** category.
- Information on CAN communication modules and CANopen system bus interfaces of other Lenze devices is provided in the "CAN" communication manual in the Lenze library.

## 9.1 General information

For many years the system bus (CAN) based on the CANopen communication profile has been integrated in Lenze controllers. Due to the lower number of data objects available, the functionality and compatibility of the old system bus are lower as compared with CANopen. For parameter setting, two parameter data channels are always available to the user while CANopen provides only one active parameter data channel (along with the possibility to establish further channels).

The system bus (CANopen) of the Servo Drives 9400 has been developed from the system bus (CAN) of the controller of the 9300 series with the following properties:

- Full compatibility according to CANopen DS301 V4.02.
- Support of the NMT master/slave function "Node Guarding" (DS301 V4.02).
- Support of the "Heartbeat" NMT slave function (DS301, V4.02).
- There are no restrictions regarding the selection of the node addresses.
- Number of parameterisable server and client SDO channels:
  - max. 10 channels with 1 ... 8 bytes
- Number of parameterisable PDO channels:
  - max. 4 Transmit-PDOs (TPDOs) with 1 ... 8 bytes
  - max. 4 Receive-PDOs (RPDOs) with 1 ... 8 bytes
- All PDO channels are functionally equivalent.
- Monitoring of the RPDOs for data reception
- Telegram counters for SDOs and PDOs
- Bus status diagnostics
- Boot-up telegram generation
- Emergency telegram generation
- Reset node telegram generation (in case of master configuration)
- Sync telegram generation and response to sync telegrams:
  - Data transmission/reception
  - Device-internal time base synchronisation
- Abort codes
- All CAN on board functions can be parameterised via codes
- Object directory (all mandatory functions, optional functions, indexes)



### 9.1.1 General data and application conditions

Department	Values
Communication profile	CANopen (DS301 V4.02)
Communication medium	DIN ISO 11898
Network topology	Line closed on both sides (e.g. termination by Sub-D plug, type EWZ0046)
Node addresses that can be set	1 ... 127 <ul style="list-style-type: none"> <li>Adjustable via DIP switch on the memory module (exception: memory module MM1xx) or via code <a href="#">C00350</a>.</li> </ul>
Max. number of nodes	127
Baud rate	10, 20, 50, 125, 250, 500, 800, 1000 kbit/s or automatic recognition <ul style="list-style-type: none"> <li>Adjustable via DIP switch on the memory module (exception: memory module MM1xx) or via code <a href="#">C00351</a>.</li> </ul>
Process data	<ul style="list-style-type: none"> <li>max. 4 TPDOs with 1 ... 8 bytes</li> <li>max. 4 RPDOs with 1 ... 8 bytes</li> </ul>
Parameter data	Max. 10 client and server SDO channels with 1 ... 8 bytes
Transfer mode for TPDOs	<ul style="list-style-type: none"> <li>With change of data</li> <li>Time-controlled, 1 to x ms</li> <li>After the reception of 1 to 240 sync telegrams</li> </ul>

### 9.1.2 Supported protocols

Category	Protocol
Standard PDO protocols	PDO write PDO read
SDO protocols	SDO download SDO download initiate SDO download segment
	SDO upload SDO upload initiate SDO upload segment
	SDO abort transfer
	SDO block download SDO block download initiate SDO block download end
	SDO block upload SDO block upload initiate SDO block upload end
NMT protocols	Start remote node (master and slave)
	Stop remote node (slave)
	Enter pre-operational (slave)
	Reset node (slave and local device)
	Reset communication (slave)
Monitoring protocols	Node guarding (master and slave)
	Heartbeat (heartbeat producer and heartbeat consumer)

### 9.1.3 Communication time

The communication time is the time between the start of a request and the arrival of the corresponding response.

**Tip!**

The communication times in the CAN network depend on the

- processing time in the device
- telegram run time (baud rate / telegram length)
- bus load (especially if the bus is loaded with PDOs and SDOs at a low baud rate.)

#### Servo Drives 9400 processing time

There are no interdependencies between parameter data and process data.

- Parameter data:
  - For controller-internal parameters: approx. 30 ms ± 20 ms tolerance (typically)
  - For some codes the processing time can be longer.
- Process data are transported in real time.

# 9 "CAN on board" system bus

## 9.2 Possible settings by DIP switch

### 9.2 Possible settings by DIP switch

The DIP switches on the front of the memory serve to set the baud rate and the node address.

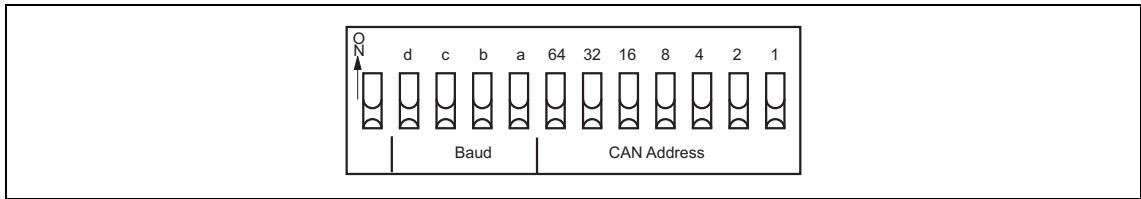

[9-1] DIP switch

#### 9.2.1 Setting the node address

The node address can be set via code [C00350](#) or with the DIP switches 1 to 64.

- The labelling on the housing corresponds to the values of the individual DIP switches for determining the node address.
- Valid address range: 1 ... 127



#### Note!

- The addresses of the nodes must differ from each other.
- All twelve DIP switches = OFF (Lenze setting):
  - At switching on, the settings under code [C00350](#) (node address) and [C00351](#) (baud rate) will become active.
- Switch the voltage supply of the standard device off and then on again to activate altered settings.

#### Example: Setting of the node address 23

DIP switch	64	32	16	8	4	2	1
Switch position	OFF	OFF	ON	OFF	ON	ON	ON
Value	0	0	16	0	4	2	1
Node address	= Sum of the values = 16 + 4 + 2 + 1 = 23						



#### Tip!

The node address resulting from the setting of the DIP switches at the last mains switching is displayed in [C00349/1](#).

### 9.2.2 Setting the baud rate

The baud rate can be set via code [C00351](#) or with the DIP switches a to d:

d	Switch positions			Baud rate
	c	b	a	
OFF	ON	ON	OFF	10 kbps
OFF	ON	OFF	ON	20 kbps
OFF	OFF	ON	ON	50 kbps
OFF	OFF	ON	OFF	125 kbps
OFF	OFF	OFF	ON	250 kbps
OFF	OFF	OFF	OFF	500 kbps
ON	ON	ON	OFF	800 kbps
OFF	ON	OFF	OFF	1 Mbps
OFF	ON	ON	ON	Automatic recognition



#### Note!

Switch the voltage supply of the standard device off and then on again to activate altered settings.



#### Tip!

The baud rate resulting from the setting of the DIP switches at the last mains switching is displayed in [C00349/2](#).

# 9 "CAN on board" system bus

## 9.3 LED status displays for the system bus







### 9.3 LED status displays for the system bus

Both upper LEDs "CAN-RUN" and "CAN-ERR" on the front of the controller inform about the CANopen state and report CANopen errors.



[9-2] LED status displays CAN-RUN and CAN-ERR

The meaning can be seen from the table below:

LED status display		Meaning	
CAN-RUN	CAN-ERR	CANopen state	CANopen error
Only CAN-ERR is on 		-	<b>Bus off</b>
CAN-RUN and CAN-ERR jitter 		Automatic detection of the baud rate is active.	
CAN-RUN is blinking every 0.2 seconds   CAN-ERR is off 		<b>Pre-Operational</b>	-
CAN-RUN is blinking every 0.2 seconds   CAN-ERR 1 x blinking, 1 s off 			<b>Warning Limit reached</b>
CAN-RUN is blinking every 0.2 seconds   CAN-ERR 2 x blinking, 1 s off 			<b>Node Guard Event</b>
Only CAN-RUN is on 		<b>Operational</b>	-
CAN-RUN on   CAN-ERR 1 x blinking, 1 s off 			<b>Warning Limit reached</b>
CAN-RUN on   CAN-ERR 2 x blinking, 1 s off 			<b>Node Guard Event</b>
CAN-RUN on   CAN-ERR 3 x blinking, 1 s off 			<b>Sync Message Error</b>
CAN-RUN is blinking every 1 second   CAN-ERR is off 		<b>Stopped</b>	-
CAN-RUN is blinking every 1 second   CAN-ERR 1 x blinking, 1 s off 			<b>Warning Limit reached</b>
CAN-RUN is blinking every 1 second   CAN-ERR 2 x blinking, 1 s off 			<b>Node Guard Event</b>

# 9 "CAN on board" system bus

## 9.4 Structure of the CAN data telegram

### 9.4 Structure of the CAN data telegram

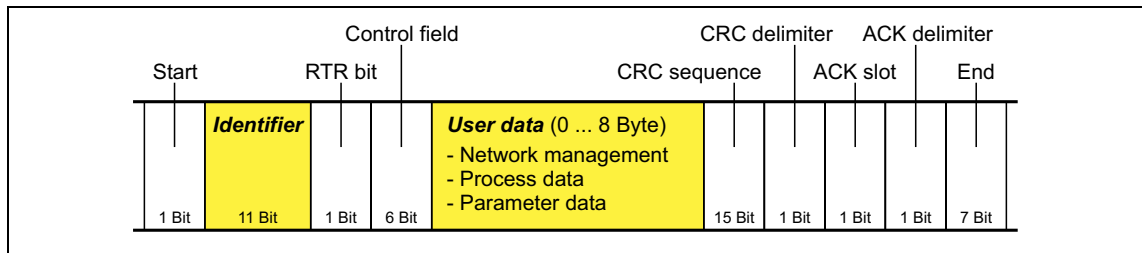

[9-3] Basic structure of the CAN telegram

The following subchapters provide a detailed description of the identifier and the user data. The other signals refer to the transfer characteristics of the CAN telegram whose description is not included in the scope of this documentation.



#### Tip!

Please visit the homepage of the CAN user organisation CiA (CAN in automation) for further information:

<http://www.can-cia.org>

#### 9.4.1 Identifier

The principle of the CAN communication is based on a message-oriented data exchange between a transmitter and many receivers. All nodes can transmit and receive quasi-simultaneously.

The identifier, also called COB-ID (abbr. for communication object identifier), is used to control which node is to receive a transmitted message. In addition to the addressing, the identifier contains information on the priority of the message and the type of user data.

The identifier consists of a basic identifier and the node address of the node to be addressed:

**Identifier (COB-ID) = basic identifier + node address (node ID)**

Exception: The identifier for process data/heartbeat/emergency objects as well as network management and sync telegrams is freely assigned by the user (either manually or automatically by the network configurator), or is permanently assigned.

### Node address (node ID)

Every node of the system bus network must be assigned to a node address (also called node ID) within the valid address range (1 ... 127) for unambiguous identification.

- Assigning a node address more than once within a network is impermissible.
- The own node address can be configured via the DIP switch of the memory module (exception: MM1xx memory module) or via code [C00350](#). ▶ [Setting the node address](#) (📖 299)

### Identifier assignment

The system bus is message-oriented instead of node-oriented. Every message has an unambiguous identification, the identifier. For CANopen, node-oriented transfer is achieved by the fact that every message has only one transmitter.

- The basic identifiers for network management (NMT) and sync as well as the basic SDO channel (SDO1) are defined in the CANopen protocol and cannot be changed.
- The basic identifiers of the PDOs are preset in the Lenze setting according to the "Predefined Connection Set" of DS301 V4.02 and can be changed via parameters/indexes, if required.
  - ▶ [Identifiers of the process data objects](#) (📖 310)

Object	Direction		Basic identifier	
	from device	to device	dec	hex
Network management (NMT)			0	0
Sync			128	80
Emergency	●		128	80
PDO1 (process data channel 1)	TPDO1	●	384	180
	RPDO1		512	200
PDO2 (Process data channel 2)	TPDO2	●	640	280
	RPDO2		768	300
PDO3 (Process data channel 3)	TPDO3	●	896	380
	RPDO3		1024	400
PDO4 (Process data channel 4)	TPDO4	●	1152	480
	RPDO4		1280	500
SDO1 (Basic SDO channel)	●		1408	580
		●	1536	600
SDO2 ... SDO10 (parameter data channel 2 ... 10)	●		1472	5C0
		●	1600	640
Node guarding, heartbeat	●		1792	700

### 9.4.2 User data

All nodes communicate by exchanging data telegrams via the system bus. The user data area of the CAN telegram either contains network management data or parameter data or process data:

#### Network management data

(NMT data)

- Control information on start, stop, reset, etc. of communication to specific nodes or to all nodes of the CAN network.

#### Process data

(PDOs – process data objects)

- Process data are transferred via the process data channel.
- Process data can be used to control the controller.
- Process data are not saved to the controller.
- Process data are transmitted between host system and nodes to ensure continuous exchange of current input and output data.
- Process data usually are unscaled/scalable raw data.
- Process data are, for instance, setpoints and actual values.

#### Parameter data

(SDOs – service data objects)

- Parameter data are the CANopen indexes or, in case of Lenze devices, the codes.
- Parameters are set, for instance, when the system is initially adjusted during commissioning or when the material of the production machine is changed.
- Parameter data are transmitted as SDOs via the parameter data channel. They are acknowledged by the receiver, i.e. the transmitter gets a feedback about the transmission being successful or not.
- The parameter data channel enables access to all Lenze codes and CANopen indexes.
- Parameter changes are automatically saved to the controller until mains switching.
- In general, the parameter transfer is not time-critical.
- Parameter data are, for instance, operating parameters, diagnostic information, and motor data.



## 9.5 Communication phases/network management

Regarding communication via the system bus, the controller distinguishes between the following statuses:

State	Explanation
"Initialisation" (Initialisation)	After switch-on, an initialisation run is carried out. <ul style="list-style-type: none"> <li>• During this phase, the controller is not involved in the data exchange via the bus.</li> <li>• The standard values are re-written to all CAN-relevant parameters.</li> <li>• After initialisation is completed, the controller is automatically set to the "Pre-Operational" status.</li> </ul>
"Pre-Operational" (before being ready for operation)	Parameter data can be received, process data are ignored.
"Operational" (ready for operation)	Parameter data and process data can be received!
"Stopped" (stopped)	Only network management telegrams can be received.

Communication object	Initialisation	Pre-Operational	Operational	Stopped
PDO			●	
SDO		●	●	
Sync		●	●	
Emergency		●	●	
Boot-up	●			
Network management (NMT)		●	●	●





### Tip!

Part of the initialisation or the entire initialisation can be carried out anew in every status by transferring the corresponding network management telegrams.

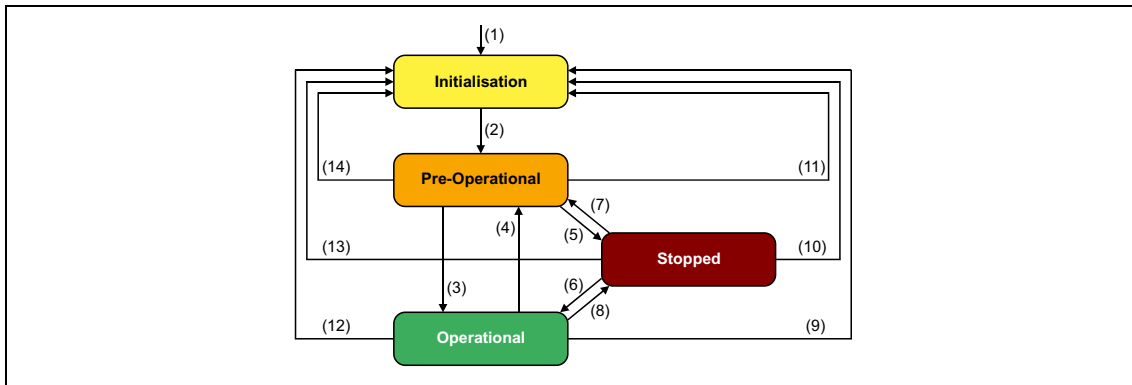
9.5.1 State transitions



[9-4] NMT status transitions in the CAN network

Transition	NMT command	Status after change	Effects on process/parameter data after status change
(1)	-	Initialisation	Initialisation starts automatically when the mains is switched on. <ul style="list-style-type: none"> <li>• During initialisation, the controller is not involved in the data exchange.</li> <li>• After the initialisation is completed, the node sends a boot-up message with an individual identifier and automatically changes to the "pre-operational" status.</li> </ul>
(2)	-	Pre-Operational	In this phase, the master determines the way in which the node(s) takes/take part in communication.
	From here, the master changes the statuses for the entire network. <ul style="list-style-type: none"> <li>• A target address included in the NMT command defines the receiver(s).</li> <li>• If the 9400 controller has been configured as CAN master, the state automatically changes to "Operational" after the waiting time has expired (<a href="#">C00378</a>) and the NMT command 0x0100 ("Start Remote Node") is sent to all nodes.</li> <li>• Data can only be exchanged via process data objects if the status is "Operational"!</li> </ul>		
(3), (6)	0x01 xx Start remote node	Operational	Network management/sync/emergency telegrams as well as process data (PDO) and parameter data (SDO) are active. Optional: When the status is changed, event and time-controlled process data (PDOs) are transmitted once.
(4), (7)	0x80 xx Enter Pre-Operational	Pre-Operational	Network management/sync/emergency telegrams and parameter data (SDO) are active.
(5), (8)	0x02 xx Stop remote node	Stopped	Only network management telegrams can be received.
(9), (10), (11)	0x81 xx Reset node	Initialisation	All CAN-relevant parameters (CiA DS 301) are initialised with the saved values.
(12), (13), (14)	0x82 xx Reset communication		All CAN-relevant parameters (CiA DS 301) are initialised with the saved values.
	Meaning of the node address in the NMT command: <ul style="list-style-type: none"> <li>• xx = 0x00: If this assignment is selected, the telegram addresses all nodes (broadcast telegram). The status of all nodes can be changed at the same time.</li> <li>• xx = Node ID: If a node address is specified, only the status of the node with the corresponding address changes.</li> </ul>		

### 9.5.2 Network management telegram (NMT)

The telegram for the network management contains identifier "0" and the command included in the user data which consists of the command byte and the node address:

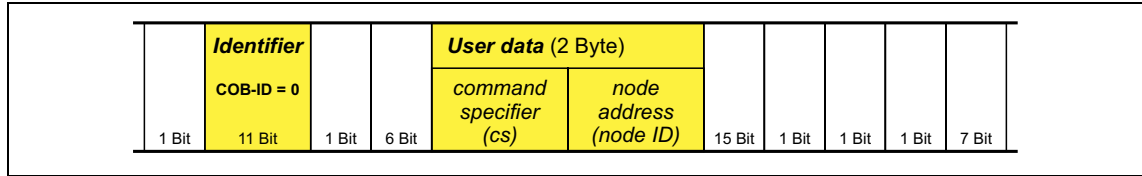

[9-5] Network management telegram for changing over the communication phases

Command specifier (cs)		NMT command
dec	hex	
1	0x01	Start remote node
2	0x02	Stop remote node
128	0x80	Enter Pre-Operational
129	0x81	Reset node
130	0x82	Reset communication

The communication phases are changed over by a node, the CAN master, for the entire network. The CAN master can also be a controller. ▶ [Parameterising the controller as CAN master](#) (📖 308)

#### Example:

Data can only be exchanged via process data objects if the status is "Operational". If the CAN master is supposed to switch all nodes connected to the bus from the "Pre-Operational" communication status to the "Operational" communication status, the identifier and user data in the transmission telegram must be set as follows:

- Identifier: 0x00 (network management)
- User data: 0x0100 ("Start remote node" NMT command to all nodes)

### 9.5.3 Parameterising the controller as CAN master

If the initialisation of the system bus and the associated status change from "Pre-Operational" to "Operational" is not effected by a superimposed host system, the controller can instead be defined to be a "quasi" master to execute this task.

The controller is configured as CAN master in [C00352](#).

- Being the CAN master, the controller sets all nodes connected to the bus (broadcast telegram) to the "Operational" communication status with the "Start remote node" NMT telegram. Only in this communication status, data can be exchanged via process data objects.
- In [C00378](#), you can set a delay time which must elapse after power-up before the controller applies the "Start Remote Node" NMT telegram to the bus.

Parameters	Info	Lenze setting	
		Value	Unit
<a href="#">C00352</a>	CAN slave/master	slave	
<a href="#">C00378</a>	CAN delay boot-up - Operational	3000	ms



#### Note!

The changes of the master/slave operation in [C00352](#) will not be activated until

- another mains switching of the controller

or

- the "Reset node" or "Reset communication" NMT telegram has been transmitted to the controller.

As an alternative to the "Reset Node" NMT telegram, the device command [C00002](#) = "91: CAN on board: Reset Node" can be used to reinitialise the CAN-specific device parameters.



#### Tip!

Master functionality is only required during the initialisation phase of the drive system.

### 9.6 Process data transfer

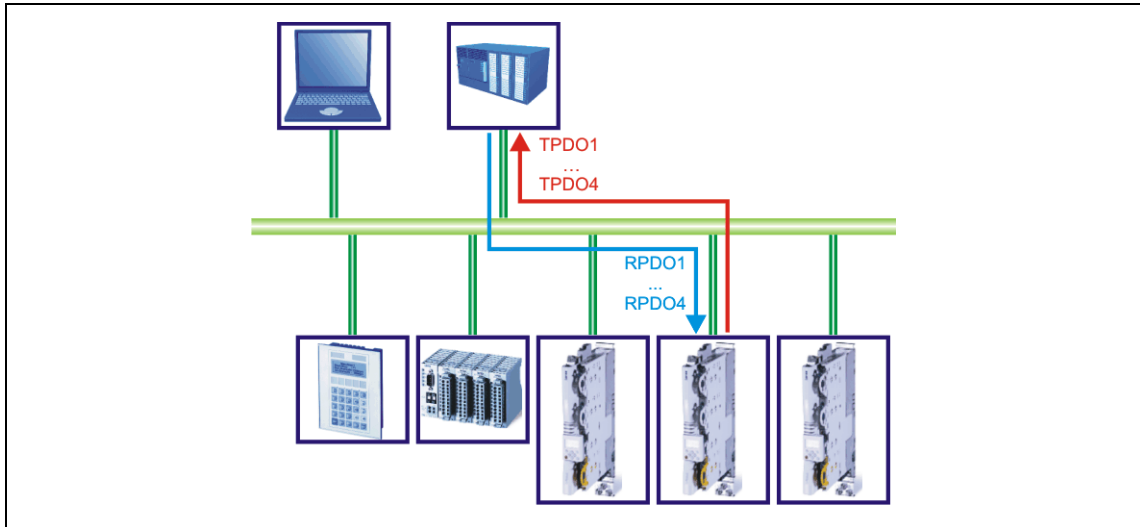

[9-6] PDO data transfer from / to the higher-level host system

For the transfer of process data, four separated process data channels (PDO1 ... PDO4) are available.

#### Definitions

- Process data telegrams between the host system and the devices are distinguished in terms of direction as follows:
  - Process data telegrams to the device (RPDO)
  - Process data telegrams from the device (TPDO)
- The CANopen process data objects are designated as seen from the node's view:
  - Receive PDOs (RPDOx): Process data object received by a node
  - Transmit PDOs (TPDOx): Process data object sent by a node



#### Note!

Data can only be exchanged via process data objects if the status is "Operational"!

▶ [Communication phases/network management](#) (📖 305)

### 9.6.1 Identifiers of the process data objects

The identifiers for the process data objects PDO1 ... PDO4 in the Lenze setting result from the basic identifier and the node address set in [C00350](#).

**Identifier (COB-ID) = basic identifier + node address (node ID)**

- The basic identifiers of the PDOs are preset in the Lenze setting according to the "Predefined Connection Set" of DS301 V4.02.
- The identifiers for the PDOs can be set individually via the Lenze codes and CANopen indexes listed in the following table. Thus, you can also set an identifier independent of the node address for certain PDOs.

Process data object	Basic identifier		Individual setting	
	dec	hex	Lenze code	CANopen index
PDO1				
RPDO1	512	0x200	<a href="#">C00321/1</a>	<a href="#">I-1400/1</a>
TPDO1	384	0x180	<a href="#">C00320/1</a>	<a href="#">I-1800/1</a>
PDO2				
RPDO2	768	0x300	<a href="#">C00321/2</a>	<a href="#">I-1401/1</a>
TPDO2	640	0x280	<a href="#">C00320/2</a>	<a href="#">I-1801/1</a>
PDO3				
RPDO3	1024	0x400	<a href="#">C00321/3</a>	<a href="#">I-1402/1</a>
TPDO3	896	0x380	<a href="#">C00320/3</a>	<a href="#">I-1802/1</a>
PDO4				
RPDO4	1280	0x500	<a href="#">C00321/4</a>	<a href="#">I-1403/1</a>
TPDO4	1152	0x480	<a href="#">C00320/4</a>	<a href="#">I-1803/1</a>



#### Note!

After the node address ([C00350](#)) has changed and a subsequent CAN reset node, the identifiers which result from the corresponding basic identifiers and the set node address are automatically set again in the subcodes of [C00320](#) and [C00321](#).



#### Tip!

The "Predefined Connection Set" can be re-established anytime using the following device commands ([C00002](#)):

- "93: CAN on board: Pred.Connect.Set" for CAN on board
- "94: CAN module: Pred.Connect.Set" for E94AYCCA communication module

### 9.6.2 Transmission type

The process data objects are transmitted in an event-controlled or time-controlled way.

- **Event-controlled:** The PDO is sent if a special device-internal event has occurred, for instance, when the data contents of the TPDO have changed or when a transmission cycle time has elapsed.
- **Synchronous:** A TPDO (or RPDO) is transmitted (or received) after the device has received a sync telegram (with identifier 0x80).
- **Cyclically:** The PDOs are transmitted in fixed time intervals after the transmission cycle time has elapsed.

The table shows that combinations of logic operations (AND, OR) are also possible between the different transmission modes:

Transmission type	PDO transmission			Logic operation
	cyclic	synchronous	event-controlled	
0		●	●	AND
1 ... 240		●		-
254, 255	●		●	OR

Transmission type	Description
0	The PDO is transmitted on an event-controlled basis with every sync (e.g. when a bit change occurs in the PDO).
1 ... 240	<b>SYNC (with response)</b> <ul style="list-style-type: none"> <li>• Selection n = 1: The PDO is transmitted with <u>every</u> sync.</li> <li>• Selection 1 &lt; n ≤ 240: The PDO is transmitted with <u>every n-th</u> sync.</li> </ul>
254, 255	<b>Event-controlled (with mask) with cyclic overlay</b> If this value is entered, the PDO transmission is event-controlled <u>or</u> cyclic. (Note: The values "254" and "255" have the same meaning). For cyclic overlay, a cycle time must be set for the respective PDO. In this case, cyclic transmission takes place in addition to event-controlled transmission (e.g. through a bit change in the PDO).

The communication parameters such as the transmission mode and cycle time can be set freely for every PDO and independently of the settings of other PDOs:

Parameters	Info	Lenze setting	
		Value	Unit
<a href="#">C00322/1...4</a>	CAN TPDOx Tx mode	254	
<a href="#">C00323/1...4</a>	CAN RPDOx Rx mode	254	
<a href="#">C00324/1...4</a>	CAN TPDOx delay time	0	1/10 ms
<a href="#">C00356/1...4</a>	CAN TPDOx cycle time	0	ms



#### Tip!

The setting can also be carried out via the following CANopen objects:

- [I-1400](#) ... [I-1403](#): Communication parameters for RPDO1 ... RPDO4
- [I-1800](#) ... [I-1803](#): Communication parameters for TPDO1 ... TPDO4

### 9.6.3 Masking of the TPDOs for event control

For TPDO1 ... TPDO4, a mask can be parameterised for every byte. In case of the event-controlled transmission of a PDO, only the masked bits are used for the event control.

- Mask "0x0" means that no bit of the corresponding byte actuates the transmission.
- Mask "0xff" means that every bit of the corresponding byte can actuate the transmission.

#### Short overview: Parameters for masking the TPDOs

Parameters	Info	Lenze setting
<a href="#">C00311/1...8</a>	CAN TPDO1 mask byte x	0x00
<a href="#">C00312/1...8</a>	CAN TPDO2 mask byte x	0x00
<a href="#">C00313/1...8</a>	CAN TPDO3 mask byte x	0x00
<a href="#">C00314/1...8</a>	CAN TPDO4 mask byte x	0x00

### 9.6.4 Monitoring of the RPDOs for data reception

For RPDO1 ... RPDO4 each, a monitoring time can be parameterised within which the RPDO must arrive. If the RPDO is not received within the monitoring time or not with the configured sync, the response parameterised for each RPDO takes place.

#### Short overview: Parameters for RPDO monitoring

Parameters	Info	Lenze setting	
		Value	Unit
<a href="#">C00357/1...4</a>	CAN RPDOx monitoring time	3000	ms
<a href="#">C00591/1...4</a>	Resp. to CAN RPDOx error	No response	



### 9.6.5 Synchronisation of PDOs via sync telegram

During cyclic transmission, one or more PDOs are transmitted/received in fixed time intervals. An additional specific telegram, the so-called sync telegram, is used for synchronising cyclic process data.

- The sync telegram is the trigger point for the transmission of process data from the slaves to the master and for the acceptance of process data from the master in the slaves.
- For sync-controlled process data processing, the sync telegram must be generated accordingly.
- The response to a sync telegram is determined by the transmission type selected.
  - ▶ [Transmission type](#) (311)

#### Basic workflow

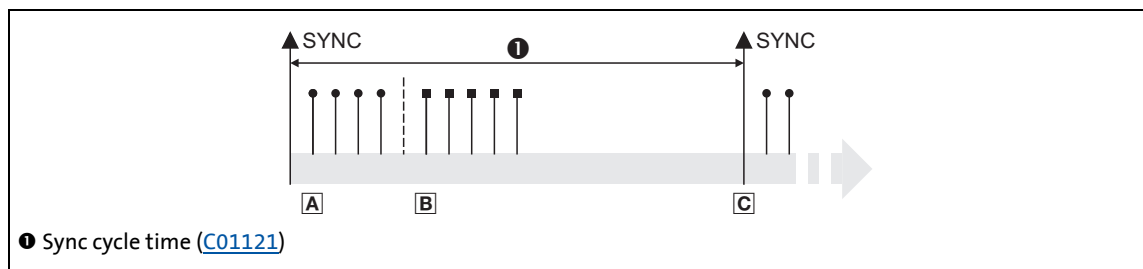

[9-7] Sync telegram

- After the sync telegram has been received, the slaves transmit the synchronous process data to the master (TPDOs). The master reads them as process input data.
- When the transmission process is completed, the slaves receive (RPDOs) the process output data (of the master).
  - All other telegrams (e.g. parameters or event-controlled process data) are accepted acyclically by the slaves after the transmission is completed.
  - Illustration [9-7] does not include acyclic data. However, they need to be considered when dimensioning the cycle time.
- The data are accepted in the slave with the next sync telegram if the Rx mode is set to 1 ... 240. If the Rx mode is 254 or 255, the data are accepted in the next device cycle, irrespective of the sync telegram.

### 9.6.5.1 Parameter setting

#### Short overview: Parameters for the synchronisation via sync telegram

Parameters	Info	Lenze setting		Assignment	
		Value	Unit	Sync master	Sync slave
<a href="#">C00367</a>	CAN SYNC Rx identifier	128			●
<a href="#">C00368</a>	CAN SYNC Tx identifier	128		●	
<a href="#">C00369/1</a>	CAN sync transmission cycle time	0	ms	●	
<a href="#">C01120</a>	Sync source	Off			●
<a href="#">C01121</a>	Sync cycle time For synchronisation via the system bus, only integer multiples of 1000 µs should be set.	1000	µs		●
<a href="#">C01122</a>	Sync phase position	400	µs		●
<a href="#">C01123</a>	Sync tolerance	0	µs		●
<a href="#">C01124</a>	Sync PLL increment	109	ns		●
<a href="#">C01130</a>	Sync application cycle	1000	µs		●



#### Note!

The following codes are ineffective if the servo inverter is synchronised via a communication module:

- [C01121](#)
- [C01122](#)
- [C01123](#)
- [C01124](#)

#### Sync source

[C01120](#) is used to select the source of the synchronisation signals. Basically, only one source can synchronise the node.

#### Sync cycle time

Time interval at which the internal phase-locking loop (PLL) expects the synchronisation signals.

The sync cycle time must be set in [C01121](#), matching the cycle of the synchronisation source selected in [C01120](#).

- Example 1:  
For the system bus the interval between two synchronisation signals has been set with 2 ms. If the system bus is to be used as synchronisation source, a sync cycle time of 2000 µs must be set in [C01121](#).
- Example 2:  
The cycle time of the application task running in the user application must also comply exactly with the sync cycle time.  
Therefore, the following constellation can not be implemented:
  - Cycle time of the application task: 2 ms
  - Sync cycle time: 4 ms

### Sync phase position

The phase position defines the zero point of time for the application relating to the synchronisation signal (bus cycle). Since PDO processing is integrated in the system part of the application, the instant of the PDO acceptance also changes if the phase position is changed.

- If 0 is set, the application is started together with the synchronisation signal.
- If a value > 0 is set, the application starts by the set time interval before the synchronisation signal arrives (the phase position acts negatively).

Example: If the phase position is set to 400 µs, the system part of the application starts 400 µs before the synchronisation signal arrives.



#### Note!

From software version V3.0:

The effect of the sync phase position can be affected by the application cycle set in [C01130](#). For the Lenze setting of [C01130](#) the behaviour remains as before.

### Sync tolerance

Time slot for monitoring the synchronisation signal via the system block **LS\_SyncInput**. ▶ [System block "LS\\_SyncInput" \(367\)](#)

- If the last synchronisation signal has been within this time slot around the expected value, the *SYNC\_bSyncInsideWindow* output of the **LS\_SyncInput** system block is set to TRUE.
- This setting does not affect the synchronisation process.

### Sync PLL increment

If the cycle times of the synchronisation signal and the phase-locking loop (PLL) differ from each other, the setting in [C01124](#) defines the increment with which the phase-locking loop can be readjusted.

- The recommended reset time for the system bus as synchronisation source with regard to occurring deviations is 109 ns (Lenze setting).

**Sync application cycle**

This parameter influences the effect of the sync phase position ([C01122](#)) with regard to the instant of acceptance of the synchronous PDOs by the application or the instant of transmission of the synchronous PDOs to the system bus.

The following applies to software versions lower than V3.0:

- The sync application cycle is fixedly set to 1000 µs.
- The resulting PDO delay can be calculated with the following formula taking into consideration an internal processing time of 150 s:  

$$\text{PDO delay} = (\text{sync cycle time} - \text{sync phase position} + 150 \mu\text{s}) \text{ modulo } 1000$$

The following applies from software version V3.0:

- The sync application cycle can be set in [C01130](#). The value set is automatically rounded down to full 1000 µs.
- The resulting PDO delay can be calculated with the following formula, taking an internal processing time of 150 s into consideration:  

$$\text{PDO delay} = (\text{sync cycle time} - \text{sync phase position} + 150 \mu\text{s}) \text{ modulo } \text{C01130}$$



**Note!**

If the sync application cycle in [C01130](#) is set higher than the sync cycle time ([C01121](#)), the response is undefined. The same applies if the sync phase position ([C01122](#)) is set higher than the sync cycle time ([C01121](#)).

Usually, no synchronous PDOs are then applied to the system bus anymore.

**9.6.5.2 Effect of C01130 on the sync phase position**

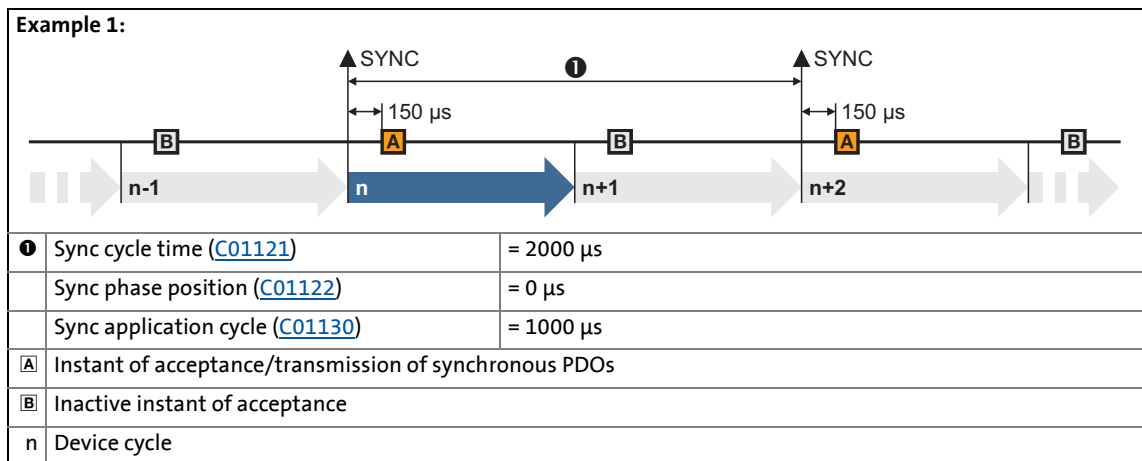

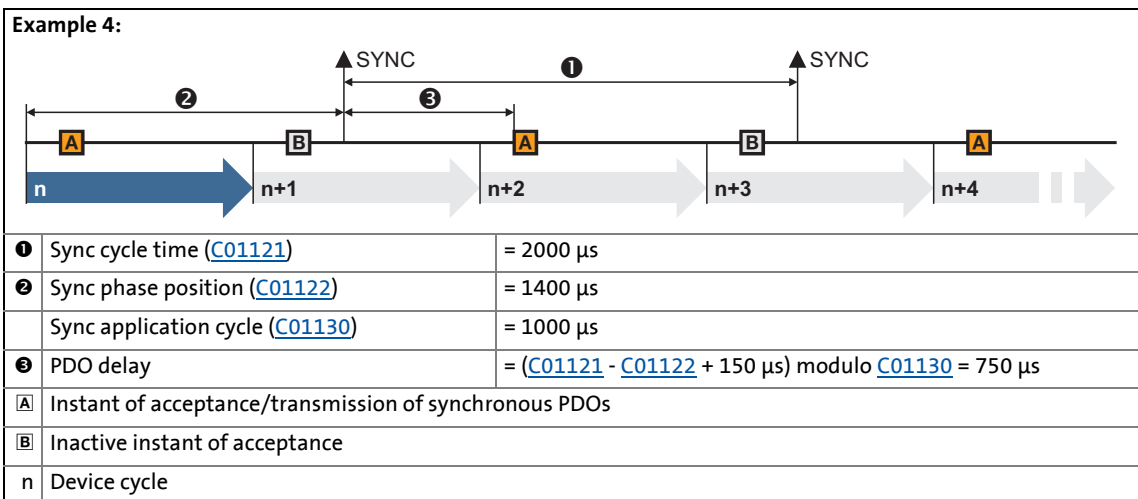
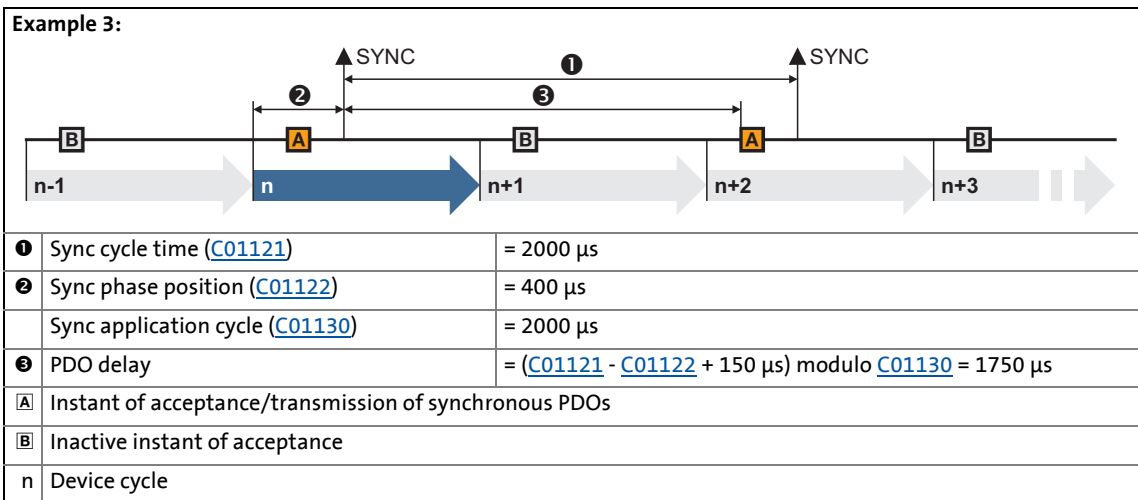
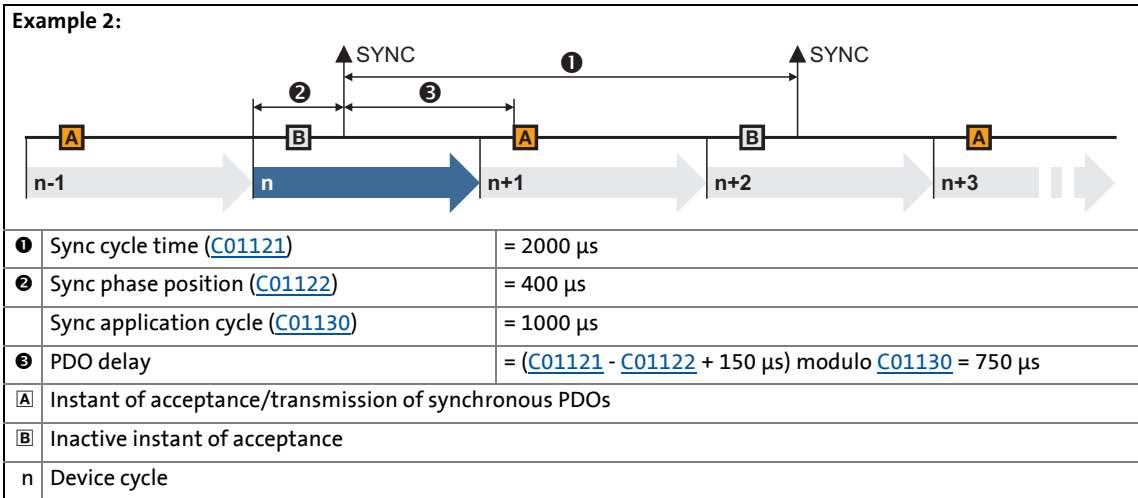

### 9.7 Parameter data transfer

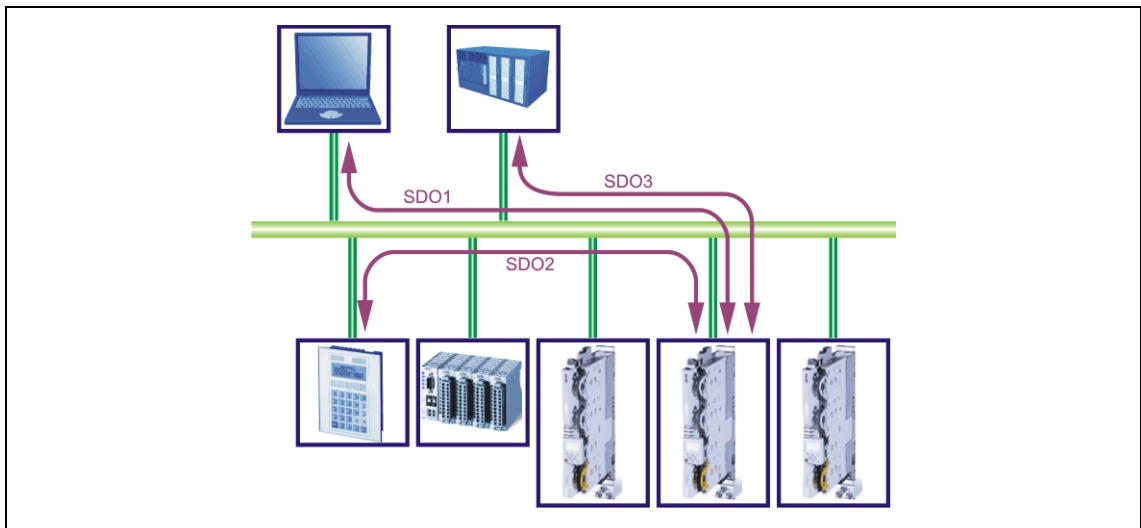

[9-8] Parameter data transfer via the available parameter data channels

Parameters are values stored in codes on Lenze controllers.

Ten separate parameter data channels are available for parameter setting, enabling the simultaneous connection of several devices for configuration.

Parameter data are transmitted via the system bus as SDOs ("Service Data Objects") and acknowledged by the receiver. The SDO enables read and write access to the object directory. Indexes (e.g. [I-1000](#)) ensure access to parameters and functions included in the object directory. To transfer SDOs, the information contained in the user data must comply with the CAN-SDO protocol.

### 9.7.1 Identifiers of the parameter data objects

The identifiers for the parameter data objects SDO1 ... SDO10 in the Lenze setting result from the basic identifier and the node address set in [C00350](#).

**Identifier (COB-ID) = basic identifier + node address (node ID)**

- The basic identifiers of the SDOs are preset in the Lenze setting according to the "Predefined Connection Set" of DS301 V4.02.

Parameter data object	Direction		Basic identifier	
	from device	to device	dec	hex
SDO1 (Parameter data channel 1)	●		1408	580
		●	1536	600
SDO2 ... 10 (parameter data channel 2 ... 10)	●	●	deactivated	
Node guarding, heartbeat	●		1792	700
Boot-up	●		1792	700



#### Note!

Please observe that the parameter data channels 2 ... 10 are deactivated in the Lenze setting.

The procedure for activating these parameter data channels is explained in the description of parameters [C00372](#) and [C00373](#) and the description for the implemented CAN object [I-1201](#). ▶ [Example](#) (📖 355)

### 9.7.2 User data

#### Structure of the user data of the parameter data telegram

1st byte	2nd byte	3rd byte	4th byte	5th byte	6. byte	7th byte	8th byte
Command	Index		Subindex	Data 1	Data 2	Data 3	Data 4
	LOW byte	HIGH byte		LOW word		HIGH word	
				LOW byte	HIGH byte	LOW byte	HIGH byte



#### Note!

For the user data, the Motorola format is used.

▶ [Parameter data telegram examples](#) (📖 325)

The following subchapters provide detailed information on user data.

### 9.7.2.1 Command

1st byte	2nd byte	3rd byte	4th byte	5th byte	6. byte	7th byte	8th byte
<b>Command</b>	<b>Index</b>		<b>Subindex</b>	<b>Data 1</b>	<b>Data 2</b>	<b>Data 3</b>	<b>Data 4</b>
	LOW byte	HIGH byte		LOW word		HIGH word	
				LOW byte	HIGH byte	LOW byte	HIGH byte

The following commands can be transmitted or received for writing and reading the parameters:

Command	1st byte		Data length	Info
	hex	dec		
Write request	0x23	35	4 bytes	Writing of a parameter to the controller.
	0x2B	43	2 bytes	
	0x2F	47	1 byte	
	0x21	33	Block	
Write response	0x60	96	4 bytes	Controller acknowledges a write request.
Read request	0x40	64	4 bytes	Reading of a parameter from the controller.
Read response	0x43	67	4 bytes	Controller's response to a read request with the current parameter value.
	0x4B	75	2 bytes	
	0x4F	79	1 byte	
	0x41	65	Block	
Error response	0x80	128	4 bytes	Response from the controller when the read/write request could not be executed correctly. ▶ <a href="#">Error messages</a> (322)

More precisely, the command byte comprises the following information:

Command	1st byte							
	Command specifier (cs)			Toggle (t)	Length*		E	s
	Bit 7	Bit 6	Bit 5	Bit 4	Bit 3	Bit 2	Bit 1	Bit 0
Write request	0	0	1	0	0/1	0/1	1	1
Write response	0	1	1	0	0	0	0	0
Read request	0	1	0	0	0	0	0	0
Read response	0	1	0	0	0/1	0/1	1	1
Error response	1	0	0	0	0	0	0	0

\*Bit coding of the length: 00 = 4 bytes, 01 = 3 bytes, 10 = 2 bytes, 11 = 1 byte  
e: expedited (shortened block service)  
s: segmented (normal block service)



**Tip!**

More commands are defined in CANopen specification DS301, V4.02 (e.g. segmented transfer).



# 9 "CAN on board" system bus

## 9.7 Parameter data transfer

### 9.7.2.2 Addressing by means of index and subindex

1st byte	2nd byte	3rd byte	4th byte	5th byte	6. byte	7th byte	8th byte
Command	Index		Subindex	Data 1	Data 2	Data 3	Data 4
	LOW byte	HIGH byte		LOW word		HIGH word	
				LOW byte	HIGH byte	LOW byte	HIGH byte

A parameter (a Lenze code) is addressed as per the following formula:  
**Index = 24575 - (Lenze code number)**

#### Example

The [C00011](#) parameter (motor reference speed) is to be addressed.

Calculation:

- Index:
  - Decimal:  $24575 - 11 = 24564$
  - Hexadecimal:  $0x5FFF - 0xB = 0x5FF4$
- Subindex: 0x00 (subindex 0 since the parameter does not have any subcodes)

Entries:

1st byte	2nd byte	3rd byte	4th byte	5th byte	6. byte	7th byte	8th byte
Command	Index		Subindex	Data 1	Data 2	Data 3	Data 4
	0xF4	0x5F	0x00				

### 9.7.2.3 Data 1 ... Data 4

1st byte	2nd byte	3rd byte	4th byte	5th byte	6. byte	7th byte	8th byte
Command	Index		Subindex	Data 1	Data 2	Data 3	Data 4
	LOW byte	HIGH byte		LOW word		HIGH word	
				LOW byte	HIGH byte	LOW byte	HIGH byte

Maximally 4 bytes are available for parameter value entries. Depending on the data format, they are assigned as follows:

5th byte	6. byte	7th byte	8th byte
Parameter value (1 byte)	0x00	0x00	0x00
Parameter value (2 bytes)		0x00	0x00
LOW byte	HIGH byte		
Parameter value (4 bytes)			
LOW word		HIGH word	
LOW byte	HIGH byte	LOW byte	HIGH byte



#### Note!

The "Factor" column of the [Table of attributes](#) contains a so-called scaling factor for all Lenze parameters. The scaling factor is relevant to the transfer of parameter values which have one or more decimal positions in the parameter list.

If the scaling factor is > 1, the value must be multiplied by the indicated scaling factor prior to transmission to be able to transfer the value as an integer. At the SDO client end, the integer must be divided by the scaling factor to obtain the original value including decimal positions again.

#### Example

For a code with the scaling factor "100" and the data format U32 the value "123.45" is to be transmitted.

Calculation:

- Value to be transmitted = scaling factor x value
- Data (1 ... 4) = 100 x 123.45 = 12345 (0x00 00 30 39)

Entries:

1st byte	2nd byte	3rd byte	4th byte	5th byte	6. byte	7th byte	8th byte
Command	Index		Subindex	Data 1	Data 2	Data 3	Data 4
				0x39	0x30	0x00	0x00

### 9.7.2.4 Error messages

1st byte	2nd byte	3rd byte	4th byte	5th byte	6. byte	7th byte	8th byte
Command	Index		Subindex	Error code			
0x80 (128)	LOW byte	HIGH byte		LOW word		HIGH word	
				LOW byte	HIGH byte	LOW byte	HIGH byte

In the event of an error, the addressed node generates a telegram with the "Error response" (0x80) command.

- The telegram includes the index and subindex of the code where the error occurred.
- The error code is entered in bytes 5 ... 8.
  - The error codes are standardised according to DS301, V4.02.
  - The representation of the error codes is provided in reverse read direction (see example below).

### Example

Representation of error code "0x06 04 00 41" in bytes 5 ... 8:

1st byte	2nd byte	3rd byte	4th byte	5th byte	6. byte	7th byte	8th byte
Command	Index		Subindex	Error code			
				0x41	0x00	0x04	0x06

### Meaning of the error codes

Error code	Explanation
0x0503 0000	Toggle bit not changed.
0x0504 0000	SDO protocol expired.
0x0504 0001	Invalid or unknown client/server command specifier.
0x0504 0002	Invalid block size (block mode only).
0x0504 0003	Invalid processing number (block mode only).
0x0504 0004	CRC error (block mode only).
0x0504 0005	Memory does not suffice.
0x0601 0000	Object access not supported.
0x0601 0001	Attempted read access to a writable only object.
0x0601 0002	Attempted write access to a readable only object.
0x0602 0000	Object not listed in object directory.
0x0604 0041	Object not mapped to PDO.
0x0604 0042	Number and length of objects to be transferred longer than PDO length.
0x0604 0043	General parameter incompatibility.
0x0604 0047	General internal device incompatibility.
0x0606 0000	Access denied because of hardware error.
0x0607 0010	Unsuitable data type (unsuitable service parameter length).
0x0607 0012	Unsuitable data type (service parameter length exceeded).
0x0607 0013	Unsuitable data type (service parameter length too short).
0x0609 0011	Subindex does not exist.
0x0609 0030	Parameter value range exceeded.
0x0609 0031	Parameter values too high.
0x0609 0032	Parameter values too low.
0x0609 0036	Maximum value falls below minimum value.
0x0800 0000	General error.
0x0800 0020	Data cannot be transferred or saved for application.
0x0800 0021	Data cannot be transferred or saved for application due to local control.
0x0800 0022	Data cannot be transferred or saved for application due to current device status.
0x0800 0023	Dynamic generation of object directory failed or no object directory available (e.g. object directory generated from file, generation not possible because of a file error).

# 9 "CAN on board" system bus

## 9.7 Parameter data transfer

### 9.7.3 Parameter data telegram examples

#### 9.7.3.1 Read parameters

**Task:** The heatsink temperature of 43 °C (code [C00061](#), data format INTEGER32, scaling factor 1) is to be read from the controller with node address 5.

#### Telegram to drive

Identifier	User data							
	1st byte	2nd byte	3rd byte	4th byte	5th byte	6. byte	7th byte	8th byte
	Command	Index		Subindex	Data 1	Data 2	Data 3	Data 4
0x0605	0x40	0xC2	0x5F	0x00	0x00	0x00	0x00	0x00

Explanations on the telegram to the drive	
Identifier	= 1536 + node address = 1536 + 5 = 1541 = 0x0605 (1536 = SDO1 basic identifier to the controller)
Command	= 0x40 = "Read request" (read request of a parameter from the controller)
Index	= 24575 - code number = 24575 - 61 = 24514 = 0x5FC2
Subindex	= 0 (code <a href="#">C00061</a> does not have any subcodes)

#### Response telegram from drive (if data have been correctly transmitted)

Identifier	User data							
	1st byte	2nd byte	3rd byte	4th byte	5th byte	6. byte	7th byte	8th byte
	Command	Index		Subindex	Data 1	Data 2	Data 3	Data 4
0x0585	0x43	0xC2	0x5F	0x00	0x2B	0x00	0x00	0x00

Explanations on the telegram from the drive	
Identifier	= 1408 + node address = 1408 + 5 = 1413 = 0x0585 (1408 = SDO1 basic identifier from the controller)
Command	= 0x43 = "Read Response" (response to read request with current value)
Index	as in telegram to the drive
Subindex	
Data 1 ... 4	= 0x0000002B = 43 [°C]

### 9.7.3.2 Write parameters

**Task:** The rated current of the connected motor with  $I_{\text{rated}} = 10.2 \text{ A}$  (code [C00088](#)) is to be entered in the controller.

#### Telegram to drive

Identifier	User data							
	1st byte	2nd byte	3rd byte	4th byte	5th byte	6. byte	7th byte	8th byte
	Command	Index		Subindex	Data 1	Data 2	Data 3	Data 4
0x0602	0x23	0xA7	0x5F	0x00	0x66	0x00	0x00	0x00

Explanations on the telegram to the drive	
Identifier	= 1536 + node address = 1536 + 2 = 1538 = 0x0602 (1536 = SDO1 basic identifier to the controller)
Command	= 0x23 = "Write request" (write request of a parameter to the controller)
Index	= 24575 - code number = 24575 - 88 = 24487 = 0x5FA7
Subindex	= 0 (code <a href="#">C00088</a> does not have any subcodes)
Data 1 ... 4	= 10,2 x 10 = 102 = 0x00000066 (Value for motor current, data type U32; display factor 1/10)

#### Response telegram from drive (if data have been correctly transmitted)

Identifier	User data							
	1st byte	2nd byte	3rd byte	4th byte	5th byte	6. byte	7th byte	8th byte
	Command	Index		Subindex	Data 1	Data 2	Data 3	Data 4
0x0582	0x60	0xA7	0x5F	0x00	0x00	0x00	0x00	0x00

Explanations on the telegram from the drive	
Identifier	= 1408 + node address = 1408 + 2 = 1410 = 0x0582 (1408 = SDO1 basic identifier from the controller)
Command	= 0x60 = "Write response" (Acknowledgement of the write access from the controller)
Index	as in telegram to the drive
Subindex	

### 9.7.3.3 Read block parameters

**Task:** The firmware version (code [C00099](#)) is to be read from the parameter set of the controller with node address "12". The firmware version has a length of 11 ASCII characters which are transmitted as a block parameter. Depending on the block, the data width from the 2nd to 8th byte is assigned within the user data.

#### Telegram 1 to the drive: Read request

Identifier	User data							
	1st byte	2nd byte	3rd byte	4th byte	5th byte	6. byte	7th byte	8th byte
	Command	Index		Subindex	Data 1	Data 2	Data 3	Data 4
0x060C	0x40	0x9C	0x5F	0x00	0x00	0x00	0x00	0x00

Explanations on the telegram to the drive	
Identifier	= 1536 + node address = 1536 + 12 = 1548 = 0x060C (1536 = SDO1 basic identifier to the controller)
Command	= 0x40 = "Read request" (read request of a parameter from the controller)
Index	= 24575 - code number = 24575 - 99 = 24476 = 0x5F9C
Subindex	= 0 (code <a href="#">C00099</a> does not have any subcodes)

#### Response telegram 1 from the drive: Indication of the block length (11 characters)

Identifier	User data							
	1st byte	2nd byte	3rd byte	4th byte	5th byte	6. byte	7th byte	8th byte
	Command	Index		Subindex	Data 1	Data 2	Data 3	Data 4
0x058C	0x41	0x9C	0x5F	0x00	0x0B	0x00	0x00	0x00

Explanations on the telegram from the drive	
Identifier	= 1408 + node address = 1408 + 12 = 1420 = 0x058C (1408 = SDO1 basic identifier from the controller)
Command	= 0x41 = "Read response" (response is block telegram)
Index	as in telegram to the drive
Subindex	
Data 1 ... 4	= 0x0000000B = data length of 11 characters in the ASCII format

### Telegram 2 to the drive: Request of the 1st data block

Identifier	User data							
	1st byte	2nd byte	3rd byte	4th byte	5th byte	6. byte	7th byte	8th byte
	Command	Data 1	Data 2	Data 3	Data 4	Data 5	Data 6	Data 7
0x060C	0x60	0x00	0x00	0x00	0x00	0x00	0x00	0x00

Explanations on the telegram to the drive	
Command	= 0x60 = "Read segment request" (request: read data block) • Bit 4 = 0 (toggle bit)
	<b>Influence of the toggle bit on the request command</b> The blocks are toggled one after another, i.e. the request is made with the "0x60" (= 0110*0000 <sub>bin</sub> ) command, then with the "0x70" (= 0111*0000 <sub>bin</sub> ) command, and then again with the "0x60" command, etc. * Toggle bit

### Response telegram 2 from the drive: Transmission of the 1st data block

Identifier	User data							
	1st byte	2nd byte	3rd byte	4th byte	5th byte	6. byte	7th byte	8th byte
	Command	Data 1	Data 2	Data 3	Data 4	Data 5	Data 6	Data 7
0x058C	0x00	0x30	0x31	0x2E	0x30	0x30	0x2E	0x30
		0 <sub>asc</sub>	1 <sub>asc</sub>	·asc	0 <sub>asc</sub>	0 <sub>asc</sub>	·asc	0 <sub>asc</sub>

Explanations on the telegram to the drive	
Command	= 0x00 = 00000000 <sub>bin</sub> • Bit 4 = 0 (toggle bit)
	<b>Influence of the toggle bit on the transmission command</b> <ul style="list-style-type: none"> <li>• The 1st response of the controller in the command byte is "0x0000*0000<sub>bin</sub>" if bytes 2 ... 8 are completely filled with data and other telegrams are following.</li> <li>• The 2nd response of the controller in the command byte is "0x0001*0000<sub>bin</sub>" if bytes 2 ... 8 are completely filled with data and other telegrams are following, etc.</li> </ul> * Toggle bit
Data 1 ... 7	= "01.00.0" (ASCII representation)



**Telegram 3 to the drive: Request of the 2nd data block**

Identifier	User data							
	1st byte	2nd byte	3rd byte	4th byte	5th byte	6. byte	7th byte	8th byte
	Command	Data 1	Data 2	Data 3	Data 4	Data 5	Data 6	Data 7
0x060C	0x70	0x00	0x00	0x00	0x00	0x00	0x00	0x00

Explanations on telegram 3 to the drive	
Command	= 0x70 = "Read segment request" (request: read data block) • Bit 4 = 1 (toggle bit)

**Response telegram 3 from the drive: Transmission of the 2nd data block including end identifier**

Identifier	User data							
	1st byte	2nd byte	3rd byte	4th byte	5th byte	6. byte	7th byte	8th byte
	Command	Data 1	Data 2	Data 3	Data 4	Data 5	Data 6	Data 7
0x058C	0x17	0x30	0x2E	0x30	0x30	0x00	0x00	0x00
		0 <sub>asc</sub>	·asc	0 <sub>asc</sub>	0 <sub>asc</sub>	-	-	-

Explanations on telegram 3 from the drive	
Command	= 0x17 = 00010111 <sub>bin</sub> : • Bit 0 = 1 (end of transmission) • Bit 1 ... bit 3 = 011 <sub>bin</sub> (3 bytes do not contain any data) • Bit 4 = 1 (toggle bit)
	<b>Influence of the final bit and the residual data length on the transmission command</b> • The end of transmission is signalled via the set final bit 0. • Bits 1 ... 3 reveal the number of bytes that do not contain any data anymore. * Toggle bit
Data 1 ... 7	= "0.00" (ASCII representation) The result of the data block transmission is: "01.00.00.00"

### 9.8 Diagnostics

The display parameters listed in the following table serve to request current information on the system bus for diagnostic purposes, e.g. using the keypad, via a bus system, or using »Engineer« (when an online connection has been established to the controller).

- The »Engineer« parameter list and the keypad contain these parameters in the category **CAN → CAN management**.
- A detailed description of these parameters can be found in the chapter "[Parameter reference](#)".  
([□ 724](#))

Parameters	Display
<a href="#">C00345</a>	CAN error
<a href="#">C00359</a>	CAN status
<a href="#">C00360/1</a>	CAN stuffing bit error counter
<a href="#">C00360/2</a>	CAN format error counter
<a href="#">C00360/3</a>	CAN acknow. error counter
<a href="#">C00360/4</a>	CAN bit 1 error counter
<a href="#">C00360/5</a>	CAN bit 0 error counter
<a href="#">C00360/6</a>	CAN CRC error counter
<a href="#">C00360/7</a>	CAN Tx telegram counter
<a href="#">C00360/8</a>	CAN Rx telegram counter
<a href="#">C00361/1</a>	CAN bus load: Current node load in Tx direction
<a href="#">C00361/2</a>	CAN bus load: Current node load in Rx direction
<a href="#">C00361/3</a>	CAN bus load: Current node load of faulty telegrams
<a href="#">C00361/4</a>	CAN bus load: Node peak load in Tx direction
<a href="#">C00361/5</a>	CAN bus load: Node peak load in Rx direction
<a href="#">C00361/6</a>	CAN bus load: Node peak load of faulty telegrams
<a href="#">C00390</a>	CAN error register (DS301V402)

9.9 Monitoring

9.9.1 Node guarding protocol

In a CAN network, the node guarding protocol serves to monitor the connection between the NMT master and the NMT slave(s). If the controller was parameterised as NMT master, it can monitor up to 32 NMT slaves.

Basic workflow

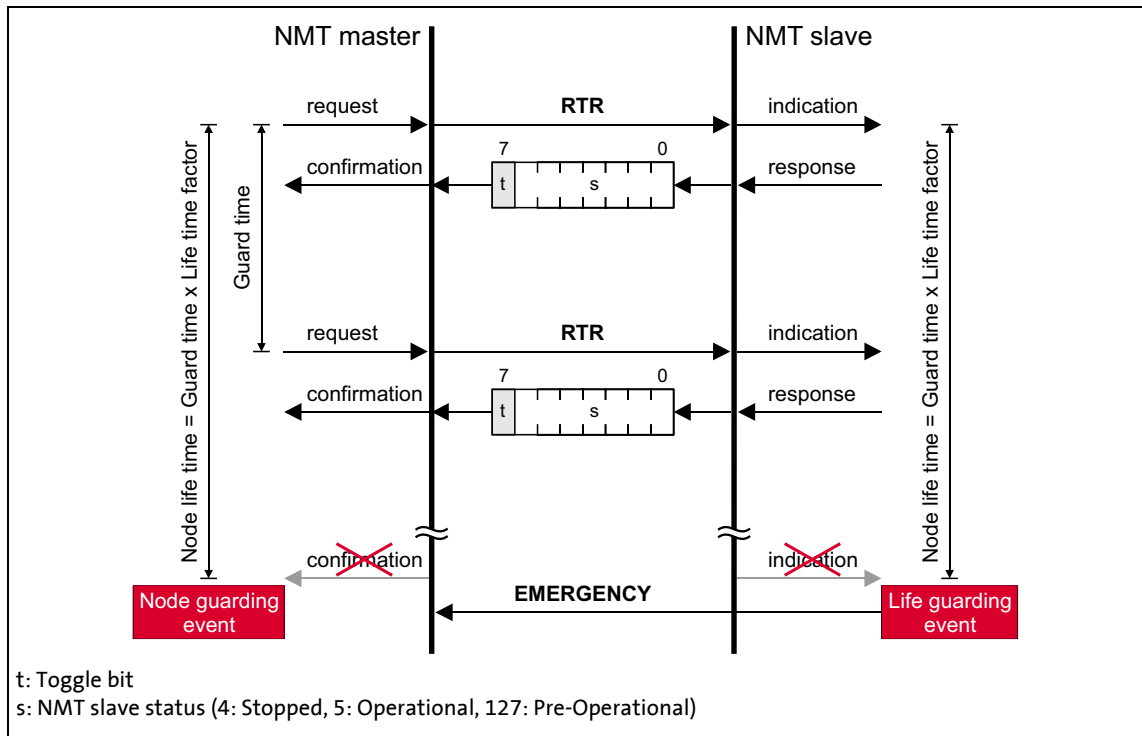

[9-9] Node guarding protocol

1. The NMT master within cyclic time intervals sends a data telegram to the NMT slave, which is referred to as "Remote Transmission Request" (RTR).
2. The NMT slave then returns a response telegram ("Response") to the NMT master.

### 9.9.1.1 Telegram structure

#### RTR telegram

- The RTR telegram from the NMT master has the following identifiers:  
Identifier (COB-ID) = 1792 + node address of the NMT slave
- The RTR telegram does not contain any user data.
- The RTR bit in the arbitration field of the RTR telegram is set to the valency LOW (dominant level).

#### Response message

- The response telegram from the requested NMT slave has the same identifier as the RTR telegram received by the NMT master.
- The user data (1 byte) contains the NMT slave status and the toggle bit (see the following description).

#### NMT slave state (s)

NMT slave status		Data								
Communication status	Decimal value (s)	(t)	NMT slave state (s)							
		Bit 7	Bit 6	Bit 5	Bit 4	Bit 3	Bit 2	Bit 1	Bit 0	
Stopped	4	0/1	0	0	0	0	0	1	0	0
Operational	5	0/1	0	0	0	0	0	1	0	1
Pre-Operational	127	0/1	1	1	1	1	1	1	1	1

#### Toggle bit (t)

- The toggle bit (t) in the response telegram has the value "0" when the node guarding protocol is activated for the first time.
- The toggle bit (t) must change its value with each response.



#### Note!

The toggle bit is monitored by the NMT master.

If a telegram is received with a toggle bit value that has not changed compared to the previously received telegram, it will be treated as if it were not received, i.e. the monitoring time is not reset and elapses further.

The toggle bit can only be reset to the value "0" by the "Reset Communication" telegram of the NMT master.

### 9.9.1.2 Parameter setting

Short overview of parameters for the "Node Guarding" monitoring function:

Parameters	Info	Lenze setting		Assignment	
		Value	Unit	master	slave
<a href="#">C00382</a>	CAN guard time	0	ms		●
<a href="#">C00383</a>	CAN life time factor	0			●
<a href="#">C00386/1...32</a>	CAN node guarding	0x00000000		●	
<a href="#">C00387</a>	CAN Node Guarding Activity	-		●	
<a href="#">C00388/1...32</a>	CAN node guarding status	-		●	
<a href="#">C00612/1...32</a>	Resp. to CAN node guarding error	No response		●	
<a href="#">C00614</a>	Resp. to CAN life guarding error	No response			●
<a href="#">C00625</a>	CAN behaviour in case of fault	Pre-operational state		●	●

Greyed out = display parameter

#### Guard time

The time interval with which the NMT master transmits the RTR telegram is the guard time.

- For each NMT slave to be monitored an individual time interval can be set.
- The RTR telegram prompts the NMT slave to send its current status.

#### Node life time

The node life time is the product of the guard time and the life time factor:

**node life time = guard time x life time factor**

- "Life time factor" and "Guard time" have to be known to the NMT master. For this, the values from the NMT slave are read at each reboot, or defined values are sent to the NMT slave at each reboot.
- It is possible to select a different "node life time" for each NMT slave to be monitored.

#### OK status

The status of the connection is ok (OK status) if within the "Node life time"

- the NMT slave has received an RTR telegram from the NMT master and
- the NMT master has received a correct response from the requested NMT slave.

In the OK status the monitoring times for the NMT master and the NMT slave are reset and the node guarding protocol is continued.

### Life guarding event

The "life guarding event" is triggered in the NMT slave if the slave has not received an RTR telegram from the NMT master within the node life time:

- In the Lenze setting, the NMT slave changes from the "Operational" communication status into the "Pre-Operational" communication status.
  - [C00625](#) or the [I-1029](#) object serve to set a status change.
- The NMT master receives an emergency telegram containing emergency error code 0x8130.
- The response parameterised in [C00614](#) takes place (Lenze setting: "No response").



#### Note!

The "Life Guarding Event" can only be triggered in the NMT slave if at least one RTR telegram has been received successfully from the NMT master.

### Node guarding event

The "node guarding event" is triggered in the NMT master if the master has not received any response to its RTR telegram from the requested NMT slave within the node life time or if the toggle bit in the response telegram has not changed within the node life time.

- In the Lenze setting, the NMT master changes from the "Operational" communication status into the "Pre-Operational" communication status.
  - [C00625](#) or the [I-1029](#) object serve to set a status change.
- The response parameterised in [C00612/1...32](#) takes place (Lenze setting: "No response"). The response in the NMT master can be set individually for each monitored node.



#### Note!

The "Node Guarding Event" can only be triggered in the NMT master if at least one response has been received successfully from the requested NMT slave.

### 9.9.1.3 Commissioning example

#### Task

A 9400 controller configured as NMT master (node 1) is to monitor another 9400 controller (node 2).

- The node guarding telegram is to be transmitted from the NMT master to the NMT slave in intervals of 1 s:
  - Guard time = 1000 ms
- The node life time is to amount to 5 seconds:
  - Node life time = guard time (1000 ms) x life time factor (5)
- If an error occurs, an error response is to be activated both in the NMT master and the NMT slave.

#### Parameter setting of the NMT master (node 1)

1. Set heartbeat producer time ([C00381](#)) to 0 ms to deactivate the heartbeat monitoring (node guarding and heartbeat must not be used simultaneously in a CANopen device).
2. Configure controller as NMT master: Set [C00352](#) = "1: Master".
3. Set guard time ([C00382](#)) to 0 ms (slave parameter).
4. Set life time factor ([C00383](#)) to 0 (slave parameter).
5. Configure monitoring for the node guarding in [C00386](#).
  - The value to be entered into a free subcode (1 ... 32) is "0x050203E8". It consists of the following:

Bit 31 ... bit 24 Life time factor	Bit 23 ... Bit 16 Node address of slave	Bit 15 ... Bit 0 Guard time
0x05	0x02	1000 [ms] = 0x03E8

6. Go to [C00612/1...32](#) and set the response required for the monitoring functions parameterised in [C00386/1...32](#) which are to take place in case of a "Node Guarding Event" in the NMT master.



#### Tip!

- [C00387](#) displays the activity of every monitoring function parameterised in [C00386/1...32](#) in a bit-coded form.
- [C00388/1...32](#) displays the node guarding status of the monitored NMT slaves.
- [C00625](#) serves to set which status change is to occur in the NMT master in case of a "Node Guarding Event".

**Parameterise NMT slave (node 2)**

1. Accept the settings made in the NMT master in [C00386](#) of the life time factor and the guard time for the NMTslave:
  - Set guard time ([C00382](#)) to 1000 ms.
  - Set life time factor ([C00383](#)) to 5.
2. Go to [C00614](#) and set the response required in case of a "Life Guarding Event" in the NMT slave.

**Tip!**

[C00625](#) serves to set which status change is to occur in case of a "Life Guarding Event" in the NMT slave.

**Node guarding telegrams**

- Remote Transmission Request:  
The RTR telegram from the NMT master has the following identifiers:  
Identifier (COB-ID) = 1792 + node address of slave = 1792 + 2 = 1794 = 0x702
- Remote Transmission Response:  
The response telegram from the NMT slave has the same identifier and the "Operational" NMT status in the user data (s = 5). ▶ [Telegram structure](#) (📖 332)



### 9.9.2 Heartbeat protocol

The heartbeat protocol can be used optionally to the node guarding protocol for monitoring nodes within a CAN network. Unlike the node guarding, this monitoring does not require a polling by means of an RTR telegram (Remote Transmission Request) from the NMT master.



#### Note!

Heartbeat and node guarding protocols must not be used simultaneously in a CANopen device. If the heartbeat producer time is set  $> 0$  ms, the heartbeat protocol is used.

#### Basic workflow

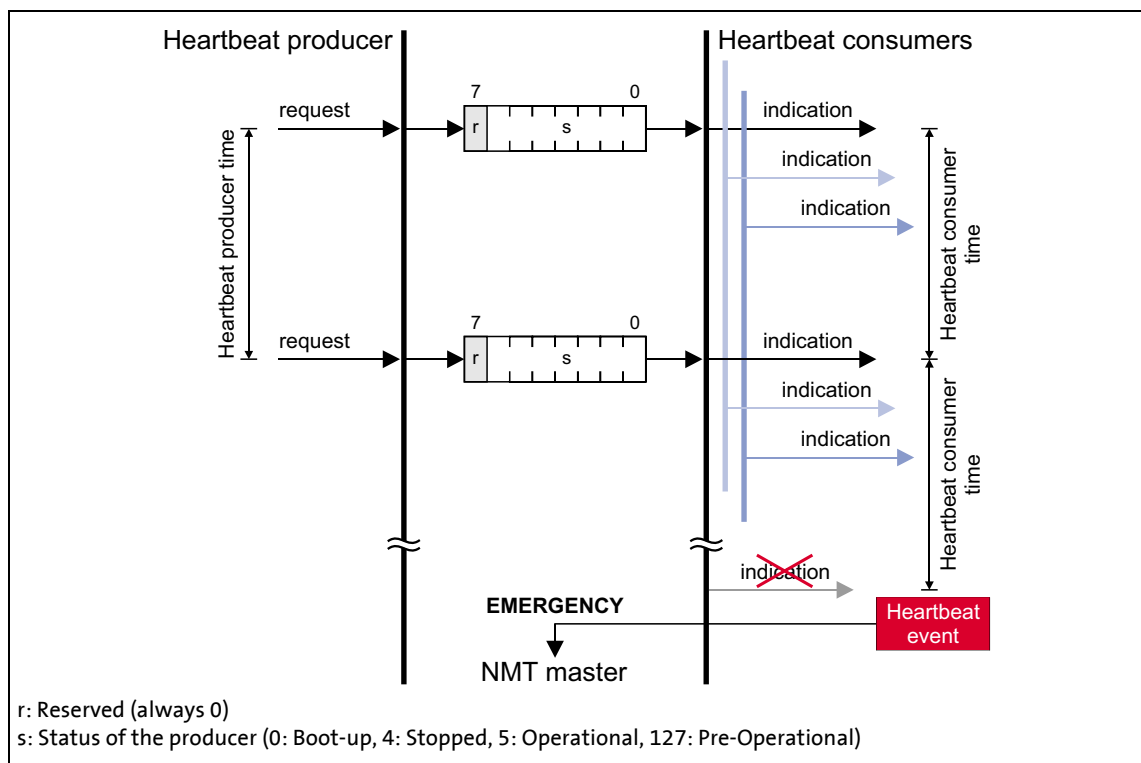

[9-10] Heartbeat protocol

1. A heartbeat producer cyclically transmits a so-called heartbeat telegram to one or more consumers.
2. The consumer(s) monitor the heartbeat telegram for arrival on a regular basis.

### 9.9.2.1 Telegram structure

- The heartbeat telegram of the producer has the following identifier:  
Identifier (COB-ID) = 1792 + producer's node address
- The user data (1 byte) contain the status (s) of the producer:

Heartbeat producer status		Data							
Communication status	Decimal value (s)	(r)	Producer status (s)						
		Bit 7	Bit 6	Bit 5	Bit 4	Bit 3	Bit 2	Bit 1	Bit 0
Boot-up	0	0	0	0	0	0	0	0	0
Stopped	4	0	0	0	0	0	1	0	0
Operational	5	0	0	0	0	0	1	0	1
Pre-Operational	127	0	1	1	1	1	1	1	1

### 9.9.2.2 Parameter setting

Short overview of the parameters for the "Heartbeat" monitoring function:

Parameters	Info	Lenze setting		Assignment	
		Value	Unit	Consumer	Producer
<a href="#">C00346</a>	CAN heartbeat activity	-		●	
<a href="#">C00347/1...32</a>	CAN heartbeat status	-		●	
<a href="#">C00381</a>	CAN Heartbeat producer time	0	ms		●
<a href="#">C00385/1...32</a>	CAN heartbeat consumer time	0x00000000		●	
<a href="#">C00613/1...32</a>	Resp. to CAN Heartbeat error	No response		●	
<a href="#">C00625</a>	CAN behaviour in case of fault	Pre-operational state		●	●

Greyed out = display parameter

#### Heartbeat producer time

Time interval for the transmission of the heartbeat telegram to the consumer(s).

- Parameterisable in [C00381](#) or via object [I-1017](#). The parameterised time is rounded down to an integer multiple of 5 ms.
- The heartbeat telegram is sent automatically as soon as a time > 0 ms is set.



#### Note!

Heartbeat and node guarding protocols must not be used simultaneously in a CANopen device. If the heartbeat producer time is set > 0 ms, the heartbeat protocol is used.

**Heartbeat consumer time**

Monitoring time for the nodes (producers) to be monitored.

- Can be parameterised in [C00385/1...32](#) or via the object [I-1016](#).
- The parameterised time is rounded down to an integer multiple of 5 ms and must have a greater value than the heartbeat producer time of the node to be monitored.
- A consumer can monitor up to 32 producers.

**Heartbeat event**

The "Heartbeat event" is activated in the consumer if it does not receive any heartbeat telegram from the producer within the heartbeat consumer time:

- In the Lenze setting, the consumer changes from the "Operational" communication status into the "Pre-Operational" communication status.
  - [C00625](#) or the [I-1029](#) object serve to set a status change.
- The NMT master receives an emergency telegram containing emergency error code 0x8130.
- The response parameterised in [C00613/1...32](#) for the corresponding producer takes place (Lenze setting: "No response").

**Note!**

The heartbeat monitoring will not start until the first heartbeat telegram of a monitored producer has been received successfully and the "Pre-Operational" NMT status has been assumed.

The boot-up telegram counts as the first heartbeat telegram.

### 9.9.2.3 Commissioning example

#### Task

A 9400 controller (node 2) configured as a heartbeat consumer is to monitor another 9400 controller (Heartbeat Producer; node 1).

- The heartbeat producer is to transmit a heartbeat telegram to the heartbeat consumer every 10 ms.
- The heartbeat consumer monitors the heartbeat telegram for arrival. A response is to be activated in the event of an error.

#### Parameterising the heartbeat producer (node 1)

1. Set the heartbeat producer time ([C00381](#)) to 10 ms.

#### Parameterising the heartbeat consumer (node 2)

1. Configure monitoring for the heartbeat in [C00385](#).
  - Note: The heartbeat consumer time must be greater than the heartbeat producer time of the node to be monitored set in [C00381](#).
  - The value to be entered into a free subcode (1 ... 32) is "0x0001000F". It consists of the following:

Bit 31 ... bit 24 Reserved	Bit 23 ... Bit 16 Node address of the producer	Bit 15 ... Bit 0 Heartbeat consumer time (integer multiple of 5 ms)
0x00	0x01	15 [ms] = 0x000F

2. Go to [C00613/1...32](#) and set the response required for the monitoring functions parameterised in [C00385/1...32](#) which are to take place in case of a "Heartbeat Event" in the consumer.



#### Tip!

- [C00346](#) displays the activity of every monitoring function parameterised in [C00385/1...32](#) in a bit-coded form.
- [C00347/1...32](#) displays the node guarding status of the monitored NMT slaves.
- [C00625](#) serves to set which status change is to occur in case of a "Heartbeat Event".

#### Heartbeat telegram

- The heartbeat telegram of the producer has the following identifier:  
Identifier (COB-ID) = 1792 + producer's node address = 1792 + 1 = 1793 = 0x701

### 9.9.3 Emergency telegram

If the error status changes because an internal device error occurs or has been eliminated, the NMT master receives an emergency telegram once with the following structure:

1st byte	2nd byte	3rd byte	4th byte	5th byte	6. byte	7th byte	8th byte
Emergency error codes		Error register	Manufacturer-specific error message				
LOW byte	HIGH byte	<a href="#">I-1001</a>	0x00 (Reserved)	LOW word		HIGH word	
See table below				LOW byte	HIGH byte	LOW byte	HIGH byte
			<ul style="list-style-type: none"> <li>• With emergency error code 0x1000: Lenze error number (displayed value in <a href="#">C00168</a>)</li> <li>• All other emergency error codes have a value of "0" here.</li> </ul>				

Emergency error codes	Error register	Cause
0x0000	0xXX	One of several errors eliminated
	0x00	One error has been eliminated (error-free status afterwards)
0x1000	0x01	Generic error <ul style="list-style-type: none"> <li>• In the standard device, an error has occurred with the error response "Fault", "Trouble", "Quick stop by trouble", "Warning", "Warning locked" or "System fault".</li> <li>• Error message is the Lenze error number (<a href="#">C00168</a>).</li> <li>• For error cause see fault error description (<a href="#">C00166</a>).</li> </ul>
0x3100	0x01	Supply voltage of standard device faulty or failed
0x8100	0x11	Communication error (warning)
0x8130	0x11	Life guarding error or heartbeat error
0x8150	0x11	Collision of identifiers (COB-IDs): An identifier parameterised for reception is also used for transmission.
0x8210	0x11	PDO length shorter than expected
0x8220	0x11	PDO length greater than expected
0x8700	0x11	Monitoring of the sync telegram

#### Example

1st byte	2nd byte	3rd byte	4th byte	5th byte	6. byte	7th byte	8th byte
Emergency error codes		Error register	Manufacturer-specific error message				
0x00	0x10	0x01	0x00 (Reserved)	0x1B	0x00	0x7B	0x00
Generic error			Lenze error message 0x007b001b: Encoder wire breakage. ▶ <a href="#">Error messages of the operating system</a> Corresponding error-free message: Value "0x00000000"				



**Tip!**

A detailed description can be found in CAN specification DS301, V4.02.

## 9.10 CANopen objects implemented

Lenze devices can be parameterised with both Lenze codes and manufacturer-independent "CANopen objects". Fully CANopen-compliant communication can only be achieved by exclusively using CANopen objects for the parameterisation. The CANopen objects described in this chapter are defined in the DS301 V4.02 CAN specification.

Many CANopen objects can be mapped on Lenze codes. The following table lists the related Lenze codes in the column "Relationship to Lenze codes".



### Note!

Some of the terms used here derive from the CANopen protocol.

### Overview of CANopen indices and their relationship to Lenze codes

CANopen object			Relationship to Lenze code
Index	Subindex	Name	
<a href="#">I-1000</a>	0	Device type	-
<a href="#">I-1001</a>	0	Error register	<a href="#">C00390</a>
<a href="#">I-1003</a>	Predefined error field		
	0	Number of errors	-
	1 ... 10	Standard error field	-
<a href="#">I-1005</a>	0	COB-ID SYNC message	<a href="#">C00367</a> <a href="#">C00368</a>
<a href="#">I-1006</a>	0	Communication cycle period	<a href="#">C00369</a>
<a href="#">I-100C</a>	0	Guard time	<a href="#">C00382</a>
<a href="#">I-100D</a>	0	Life time factor	<a href="#">C00383</a>
<a href="#">I-1010</a>	Store parameters		
	0	Highest subindex supported	-
	1	Save All Parameters	-
<a href="#">I-1011</a>	Restore default parameters		
	0	Highest subindex supported	-
	1	restore all default parameters	-
<a href="#">I-1014</a>	0	COB-ID EMCY	<a href="#">C00391</a>
<a href="#">I-1015</a>	0	Inhibit time EMCY	<a href="#">C00392</a>
<a href="#">I-1016</a>	Consumer heartbeat time		
	0	Highest subindex supported	-
	1 ... 32	Consumer heartbeat time	<a href="#">C00385/1...32</a>
<a href="#">I-1017</a>	0	Producer heartbeat time	<a href="#">C00381</a>
<a href="#">I-1018</a>	Identity object		
	0	Highest subindex supported	-
	1	Vendor ID	-
	2	Product code	-
	3	Revision number	-
	4	Serial number	-

CANopen object			Relationship to Lenze code	
Index	Subindex	Name		
<a href="#">I-1029</a>	Error behaviour			
	0	Highest subindex supported	-	
	1	Communication error	<a href="#">C00625</a>	
<a href="#">I-1200</a>	SDO1 server parameter			
	0	Highest subindex supported	-	
	1	COB-ID client → server (rx)	<a href="#">C00372/1</a>	
<a href="#">I-1201</a> ... <a href="#">I-1209</a>	SDO2 ... SDO10 server parameter			
	0	Highest subindex supported	-	
	1	COB-ID client → server (rx)	<a href="#">C00372/2...10</a>	
	2	COB-ID server → client (tx)	<a href="#">C00373/2...10</a>	
<a href="#">I-1400</a> ... <a href="#">I-1403</a>	RPDO1 ... RPDO4 communication parameter			
	0	Highest subindex supported	-	
	1	COB-ID used by RPDO	<a href="#">C00321/1...4</a>	
	2	Transmission type	<a href="#">C00323/1...4</a>	
	3	Inhibit time	-	
	4	Compatibility entry	-	
<a href="#">I-1600</a> ... <a href="#">I-1603</a>	RPDO1 ... RPDO4 mapping parameter			
	0	Number of mapped application objects in PDO	-	
	1 ... 8	Application object 1 ... 8	-	
	<a href="#">I-1800</a> ... <a href="#">I-1803</a>	TPDO1 ... TDDO4 communication parameter		
		0	Highest subindex supported	-
		1	COB-ID used by TPDO	<a href="#">C00320/1...4</a>
2		Transmission type	<a href="#">C00322/1...4</a>	
3		Inhibit time	<a href="#">C00324/1...4</a>	
<a href="#">I-1A00</a> ... <a href="#">I-1A03</a>	4	Reserved	-	
	5	Event timer	<a href="#">C00356/1...4</a>	
	TPDO1 ... TDDO4 mapping parameter			
<a href="#">I-1A00</a> ... <a href="#">I-1A03</a>	0	Number of mapped application objects in PDO	-	
	1 ... 8	Application object 1 ... 8	-	

# 9 "CAN on board" system bus

## 9.10 CANopen objects implemented | I-1000

### I-1000

Index <b>I-1000</b>	Name: <b>Device type</b>				
Subindex	Default setting	Display range (min. value   unit   max. value)		Access	Data type
0: Device type	0	0		4294967295	ro U32

The CANopen index I-1000 specifies the profile for this device. Furthermore, additional information defined in the device profile itself can be stored here.

8th byte	7th byte	6. byte	5th byte
Data 4	Data 3	Data 2	Data 1
HIGH word		LOW word	
HIGH byte	LOW byte	HIGH byte	LOW byte
<b>Additional information</b>		<b>ECAT: Device Profile Number</b>	

[9-11] Data frame assignment

### I-1001

Index: <b>I-1001</b>	Name: <b>Error register</b>				
Subindex	Default setting	Display range (min. value   unit   max. value)		Access	Data type
0: Error register	-	0		255	ro U8

Error register

- This object is related to the Lenze code [C00390](#).
- The error status in the data byte (U8) is bit coded (see the following table). Currently only bit 0 and bit 4 in the data byte contain the corresponding information.

Bit	Meaning if bit is set:
Bit 0	Generic error
Bit 1	Current error (not used)
Bit 2	Voltage error (not used)
Bit 3	Temperature error (not used)
Bit 4	Communication error
Bit 5	Device profile spec. error (not used)
Bit 6	Reserved
Bit 7	Manufacturer-specific error (not used)



## I-1003

Index: <b>I-1003</b>	Name: <b>Predefined error field</b>					
Subindex	Default setting	Setting range (min. value   unit   max. value)			Access	Data type
0: Number of errors	0	0		255	rw	U8
1 ... 10: Standard error field	-	0		4294967295	ro	U32

## Error history

This object indicates that an error has occurred in the module and in the standard device.

Subindex	Meaning
0	Number of saved error messages
1 ... 10	Display of the error list The error messages (U32) consist of a 16-bit error code and a manufacturer-specific information field comprising 16 bits.

**Note!**

The values in the "standard error field" under subindex 1 ... 10 will be deleted if the subindex "number of recorded errors" is overwritten with the value "0".

Emergency error codes	Cause	Entry in the error register ( <a href="#">I-1001</a> )
0x0000	One of several errors eliminated	0xXX
	Elimination of one single error (afterwards no more errors)	0x00
0x1000	Standard device is in error status (error response "fault", "message", "warning", "error", "quick stop by trouble", or "system error")	0x01
0x3100	Supply voltage of standard device faulty or failed	0x01
0x8100	Communication error (warning)	0x11
0x8130	Life guard error or heartbeat error	0x11
0x8150	Collision of COB-IDs: An ID parameterised for reception is also used for transmission.	0x11
0x8210	PDO length shorter than expected	0x11
0x8220	PDO length greater than expected	0x11
0x8700	Monitoring of the sync telegram	0x11

# 9 "CAN on board" system bus

9.10 CANopen objects implemented | I-1005

## I-1005

Index: <b>I-1005</b>	Name: <b>COB-ID SYNC message</b>					
Subindex	Default setting	Setting range (min. value   unit   max. value)		Access	Data type	
0: COB-ID SYNC message	0x0000 0080 or 0x8000 0080	0		4294967295	rw	U32

This object can be used to activate the generation of sync telegrams and to write the identifier value.

- This object is related to the Lenze codes [C00367](#) and [C00368](#).

### Creating sync telegrams

To create sync telegrams, bit 30 (see below) must be set to "1". The interval of the sync telegrams can be set with the object [I-1006](#).

### Writing identifiers

To receive PDOs, the value 0x80 must be entered in the 11-bit identifier in the Lenze setting (and according to CANopen specification) . This means that all modules are by default set to the same sync telegram.

- If sync telegrams are only to be received by certain communication modules, their identifiers can be entered with values up to and including 0x07FF.
- The identifier can only be changed if the communication module does not send any sync telegrams (bit 30 = "0").
- How to change the identifier:
  - Deactivate identifier (set bit 30 to "0").
  - Change identifier.
  - Activate identifier (set bit 30 to "1").

8th byte		7th byte		6. byte		5th byte	
Data 4		Data 3		Data 2		Data 1	
Bit 31	Bit 30	Bit 29 ... bit 11				Bit 10 ... bit 0	
x	0/1	Extended identifier*				11-bit identifier	
* The extended identifier is not supported. Bit 11 ... bit 29 must be set to "0".							

[9-12] Data frame assignment

# 9 "CAN on board" system bus

## 9.10 CANopen objects implemented | I-1006

### I-1006

Index: <b>I-1006</b>	Name: <b>Communication cycle period</b>					
Subindex	Default setting	Setting range (min. value   unit   max. value)			Access	Data type
0: Communication cycle period	0 µs	0	µs	65535000	rw	U32

Setting the sync telegram cycle time.

- The cycle time can be selected as "1000" or as an integer multiple of it.
- If "0 µs" is set (Lenze setting), no sync telegrams are created.
- This object is related to the Lenze code [C00369](#).

### I-100C

Index: <b>I-100C</b>	Name: <b>Guard time</b>					
Subindex	Default setting	Setting range (min. value   unit   max. value)			Access	Data type
0: Guard time	0 ms	0	ms	65535	rw	U16

Monitoring time for node guarding. ▶ [Node guarding protocol](#) (331)

- Time within the NMT slave expects the RTRs from the NMTmaster.
- The node life time is the product of the guard time and the life time factor:  
**Node Life Time = Guard Time (I-100C) x Life Time Factor (I-100D)**
- The "life guarding event" occurs in the NMT slave if the slave has not been triggered by the NMT master through an RTR within the node life time.
- With "0 ms" (Lenze setting), monitoring is not supported by the slave.
- This object is related to the Lenze code [C00382](#).

### I-100D

Index: <b>I-100D</b>	Name: <b>Life time factor</b>					
Subindex	Default setting	Setting range (min. value   unit   max. value)			Access	Data type
0: Life time factor	0	0		255	rw	U8

Life Time Factor for node guarding. ▶ [Node guarding protocol](#) (331)

- The node life time is the product of the guard time and the life time factor:  
**Node Life Time = Guard Time (I-100C) x Life Time Factor (I-100D)**
- The "life guarding event" occurs in the NMT slave if the slave has not been triggered by the NMT master through an RTR within the node life time.
- With "0" (Lenze setting), monitoring is not supported by the slave.
- This object is related to the Lenze code [C00383](#).

# 9 "CAN on board" system bus

9.10 CANopen objects implemented | I-1010

## I-1010

Index: <b>I-1010</b>	Name: <b>Store parameters</b>				
Subindex	Default setting	Setting range (min. value   unit   max. value)		Access	Data type
0: highest subindex supported	1	- (read access only)		ro	U32
1: Save all parameters	-	0	4294967295	rw	U32

Save parameters with mains failure protection.

- Corresponds to device command [C00002](#) = "11: Save start parameters".
- This command serves to save the current parameter settings of the active application with mains failure protection in the memory module of the controller.

Subindex	Meaning	
	Read	Write
0	Max. supported subindex: 1	- (A write attempt triggers the error message 0x06010002.)
1	Reading memory functions of all parameters.	Save parameters with mains failure protection.

### Read subindex 1

8th byte	7th byte	6. byte	5th byte	
Data 4	Data 3	Data 2	Data 1	
Bit 31 ... bit 2			Bit 1	Bit 0
0			0/1	0/1

[9-13] Assignment of the data telegram (read access)

Bit	Meaning	
Bit 0	0	No saving of parameters on command.
	1	Saving of parameters on command (Lenze).
Bit 1	0	No automatic saving of parameters (Lenze).
	1	Automatic saving of parameters.

### Write subindex 1

In addition to the index and subindex, the telegram data must also include the "save" signature (ASCII characters; ISO 8859) so that the parameters are stored.

- A response according to the DS301 V4.02 specification occurs while writing with a wrong identifier.

8th byte	7th byte	6. byte	5th byte
Data 4	Data 3	Data 2	Data 1
"e" = 0x65	"v" = 0x76	"a" = 0x61	"s" = 0x73

[9-14] Assignment of the data telegram (write access)

# 9 "CAN on board" system bus

9.10 CANopen objects implemented | I-1011

## I-1011

Index: <b>I-1011</b>	Name: <b>Restore default parameters</b>				
Subindex	Default setting	Setting range (min. value   unit   max. value)		Access	Data type
0: highest subindex supported	1	- (read access only)		ro	U32
1: restore all default parameters	-	0	4294967295	rw	U32

Load Lenze setting.

- Corresponds to the device command [C00002](#) = "0: Load Lenze setting".
- This command serves to reset the parameters of the active application to the Lenze setting which is stored in the firmware.

Subindex	Meaning	
	Read	Write
0	Max. supported subindex: 1	- (A write attempt triggers the error message 0x06010002.)
1	Loading of all parameters possible.	Load Lenze setting.

### Read subindex 1

8th byte	7th byte	6. byte	5th byte
Data 4	Data 3	Data 2	Data 1
Bit 31 ... bit 1			Bit 0
0			0/1

[9-15] Assignment of the data telegram (read)

Bit	setting
Bit 0	0 Parameters cannot be loaded.
	1 Parameters can be loaded (Lenze).

### Write subindex 1

In addition to the index and subindex, the telegram data must include the "load" signature (ASCII characters; ISO 8859) so that the Lenze setting can be loaded.

- A response according to the DS301 V4.02 specification occurs while writing with a wrong identifier.

8th byte	7th byte	6. byte	5th byte
Data 4	Data 3	Data 2	Data 1
"d" = 0x64	"a" = 0x61	"o" = 0x6F	"l" = 0x6C

[9-16] Assignment of the data telegram (write)

# 9 "CAN on board" system bus

## 9.10 CANopen objects implemented | I-1014

### I-1014

Index: <b>I-1014</b>	Name: <b>COB-ID EMCY</b>				
Subindex	Default setting	Setting range (min. value   unit   max. value)		Access	Data type
0: COB-ID EMCY	0x80 + node ID	0		4294967295	rw U32

If a communication error or an internal error of the communication module or the controller occurs or is acknowledged (e. g. "trouble"), an error message is sent via the system bus. For each error, the telegram is interrupted once. By means of bit 31 this function can be activated or deactivated.

- This object is related to the Lenze code [C00391](#).

8th byte		7th byte		6. byte		5th byte	
Data 4		Data 3		Data 2		Data 1	
Bit 31	Bit 30	Bit 29 ... bit 11				Bit 10 ... bit 0	
<b>0/1</b>	<b>0</b>	<b>Extended identifier*</b>				<b>11-bit identifier</b>	
* The extended identifier is not supported. Bit 11 ... bit 29 must be set to "0".							

[9-17] Data frame assignment

Bit	setting	
Bit 31	0	Emergency object is valid.
	1	Emergency object is invalid.



### Note!

The identifier can only be changed in the "emergency object invalid" status (bit 31 = 1).

### I-1015

Index: <b>I-1015</b>	Name: <b>Inhibit time EMCY</b>				
Subindex	Default setting	Setting range (min. value   unit   max. value)		Access	Data type
0: inhibit time EMCY	0	0	0.1 ms	65535	rw U32

Time which must elapse after an error message ([I-1014](#)) has been transmitted before further error messages can be sent via the bus.

- The entered value multiplied by "0.1" gives the delay time in [ms]. The values are automatically rounded up to whole values in [ms].
- This object is related to the Lenze code [C00392](#).

# 9 "CAN on board" system bus

## 9.10 CANopen objects implemented | I-1016

### I-1016

Index: <b>I-1016</b>	Name: <b>Consumer heartbeat time</b>					
Subindex	Default setting	Setting range (min. value   unit   max. value)		Access	Data type	
0: Highest subindex supported	32	- (read access only)		ro	U32	
1 ... 32: consumer heartbeat time	0	0		4294967295	rw	U32

Monitoring time for the nodes 1 ... 32 to be monitored via heartbeat. ▶ [Heartbeat protocol \(📖 337\)](#)

- The parameterised time is rounded down to an integer multiple of 5 ms and must have a greater value than the heartbeat producer time of the node to be monitored.

Subindex	Meaning	Lenze code
0	Number of nodes to be monitored	
1 ... 32	Node-ID and heartbeat time of the node 1 ... 32 to be monitored	<a href="#">C00385/1...32</a>

8th byte	7th byte	6. byte	5th byte
Data 4	Data 3	Data 2	Data 1
Bit 31 ... bit 24	Bit 23 ... Bit 16	Bit 15 ... Bit 0	
<b>0</b> (Reserved)	<b>Node ID</b>	<b>Heartbeat time</b> in [ms]	

[9-18] Data frame assignment

### I-1017

Index: <b>I-1017</b>	Name: <b>Producer heartbeat time</b>					
Subindex	Default setting	Setting range (min. value   unit   max. value)		Access	Data type	
0: Producer heartbeat time	0	0	ms	65535	rw	U32

Time interval for the transmission of the heartbeat telegram to one or several consumers. ▶ [Heartbeat protocol \(📖 337\)](#)

- The parameterised time is rounded down to an integer multiple of 5 ms.
- The heartbeat telegram is automatically sent as soon as a time > 0 ms is entered. In this case, the "node guarding" monitoring function is deactivated.
- This object is related to the Lenze code [C00381](#).

## I-1018

Index: <b>I-1018</b>	Name: <b>Identity object</b>					
Subindex	Default setting	Display range (min. value   unit   max. value)			Access	Data type
0: Highest subindex supported	see below	0		4294967295	ro	U32
1: Vendor ID						
2: Product code						
3: Revision number						
4: Serial number						

Subindex	Meaning
1	Manufacturer's identification number <ul style="list-style-type: none"> <li>The identification number allocated to Lenze by the organisation "CAN in Automation e. V." is "0x0000003B".</li> </ul>
2	Product code
	0x94001 9400 StateLine
	0x94002 9400 HighLine / ServoPLC
	0x94004 9400 regenerative power supply module
3	Main and subversion of firmware
4	Serial number

## I-1029

Index: <b>I-1029</b>	Name: <b>Error behaviour</b>					
Subindex	Default setting	Setting range (min. value   unit   max. value)			Access	Data type
0: Highest subindex supported	1	- (read access only)			ro	U8
1: Communication error	0	0		2	rw	U8

This object serves to set the communication status to which the controller is to change after a bus off, a node/life guarding event or a heartbeat event.

Subindex	Meaning	Lenze code
1	Status change after bus off, node/life guarding event or heartbeat event:	<a href="#">C00625</a>
	0 State change from "Operational" to "Pre-operational"	
	1 No state change	
	2 State change to "Stopped"	



## I-1200

Index: <b>I-1200</b>	Name: <b>SDO1 server parameter</b>					
Subindex	Default setting	Display range (min. value   unit   max. value)		Access	Data type	
0: Highest subindex supported	2	2		2	ro	U8
1: COB-ID client -> server (rx)	node ID + 0x600	0		4294967295	ro	U32
2: COB-ID server -> client (tx)	node ID + 0x580	0		4294967295	ro	U32

Identifiers for SDO server channel 1 (basic SDO channel).

- According to DS301 V4.02, the basic SDO channel can neither be changed nor deactivated.

Subindex	Meaning
1	Specification of receive identifier <ul style="list-style-type: none"> <li>• For SDO server channel 1: node address (C00350) + 0x600</li> </ul>
2	Specification of send identifier <ul style="list-style-type: none"> <li>• For SDO server channel 1: node address (C00350) + 0x580</li> </ul>

8th byte		7th byte		6. byte		5th byte	
Data 4		Data 3		Data 2		Data 1	
Bit 31	Bit 30	Bit 29 ... bit 11				Bit 10 ... bit 0	
0	0	Extended identifier*				11-bit identifier	

\* The extended identifier is not supported. Bit 11 ... bit 29 must be set to "0".

[9-19] Data frame assignment

## I-1201

Index: <b>I-1201</b>	Name: <b>SDO2 server parameter</b>				
Subindex	Default setting	Setting range (min. value   unit   max. value)		Access	Data type
0: Highest subindex supported	3	- (read access only)		ro	U8
1: COB-ID client -> server (rx)	0x80000000	0		4294967295	rw U32
2: COB-ID server -> client (tx)	0x80000000	0		4294967295	rw U32
3: Node-ID of the SDO client	1 ... 127	- (read access only)		ro	U32

Identifiers for SDO server channel 2.

- The SDO server parameter is only valid, if bit 31 is set to "0" for both transmission directions (subindex 1 and 2).
- In the Lenze setting, the SDO server channels 2 ... 10 are deactivated (bit 31 = "1").
- The identifier can only be changed if the SDO is invalid (bit 31 = "1").

Subindex	Meaning
1	Specification of receive identifier
2	Specification of send identifier
3	Node address of the client

8th byte		7th byte		6. byte		5th byte	
Data 4		Data 3		Data 2		Data 1	
Bit 31	Bit 30	Bit 29 ... bit 11				Bit 10 ... bit 0	
<b>0/1</b>	<b>0</b>	<b>Extended identifier*</b>				<b>11-bit identifier</b>	
* The extended identifier is not supported. Bit 11 ... bit 29 must be set to "0".							

[9-20] Data frame assignment

Bit	setting	
Bit 31	0	SDO is valid.
	1	SDO is invalid.

How to change the identifier:

1. Deactivate identifier (set bit 31 to "1").
2. Change identifier.
3. Activate identifier (set bit 31 to "0").

# 9 "CAN on board" system bus

9.10 CANopen objects implemented | I-1201

## Example

Parameter data channel 2 of the controller with node address 4 shall be activated.

- For this purpose, bit 31 in the subindexes 1 and 2 of the [I-1201](#) object must be set to the value "0" (≡ "SDO valid").
- The master must send the two "write request" commands to the nodes via the basic SDO channel.

### Identifier calculation

- Identifier (COB-ID) = basic identifier + node address (node ID)
- Basic identifier SDO2 from master to drive: 1600 (0x640)  
→ Identifier = 0x640 + 0x4 = 0x644
- Basic identifier SDO2 from drive to master: 1472 (0x5C0)  
→ Identifier = 0x5C0 + 0x4 = 0x5C4

### Resulting data (data 1 ... data 4)

8th byte		7th byte		6. byte		5th byte	
Data 4		Data 3		Data 2		Data 1	
Bit 31	Bit 30	Bit 29 ... bit 11				Bit 10 ... bit 0	
0	0	Extended identifier = 0				11-bit identifier = 0x644	
0x00		0x00		0x06		0x44	

[9-21] Data telegram assignment for subindex 1

8th byte		7th byte		6. byte		5th byte	
Data 4		Data 3		Data 2		Data 1	
Bit 31	Bit 30	Bit 29 ... bit 11				Bit 10 ... bit 0	
0	0	Extended identifier = 0				11-bit identifier = 0x5C4	
0x00		0x00		0x05		0xC4	

[9-22] Data telegram assignment for subindex 2

### User data assignment

1st byte	2nd byte	3rd byte	4th byte	5th byte	6. byte	7th byte	8th byte
Command	Index		Subindex	Data 1	Data 2	Data 3	Data 4
0x23	0x01	0x12	0x01	0x44	0x06	0x00	0x00

[9-23] User data assignment for writing to subindex 1

1st byte	2nd byte	3rd byte	4th byte	5th byte	6. byte	7th byte	8th byte
Command	Index		Subindex	Data 1	Data 2	Data 3	Data 4
0x23	0x01	0x12	0x02	0xC4	0x05	0x00	0x00

[9-24] User data assignment for writing to subindex 2

# 9 "CAN on board" system bus

## 9.10 CANopen objects implemented | I-1202

### I-1202

Index: <b>I-1202</b>	Name: <b>SDO3 server parameter</b>				
Subindex	Default setting	Setting range (min. value   unit   max. value)		Access	Data type
0: Highest subindex supported	3	- (read access only)		ro	U8
1: COB-ID client -> server (rx)	0x80000000	0	4294967295	rw	U32
2: COB-ID server -> client (tx)	0x80000000	0	4294967295	rw	U32
3: Node-ID of the SDO client	1 ... 127	- (read access only)		ro	U32

Setting of the identifiers for the SDO server channel 3. For description see object [I-1201](#).

### I-1203

Index: <b>I-1203</b>	Name: <b>SDO4 server parameter</b>				
Subindex	Default setting	Setting range (min. value   unit   max. value)		Access	Data type
0: Highest subindex supported	3	- (read access only)		ro	U8
1: COB-ID client -> server (rx)	0x80000000	0	4294967295	rw	U32
2: COB-ID server -> client (tx)	0x80000000	0	4294967295	rw	U32
3: Node-ID of the SDO client	1 ... 127	- (read access only)		ro	U32

Setting of the identifiers for the SDO server channel 4. For description see object [I-1201](#).

### I-1204

Index: <b>I-1204</b>	Name: <b>SDO5 server parameter</b>				
Subindex	Default setting	Setting range (min. value   unit   max. value)		Access	Data type
0: Highest subindex supported	3	- (read access only)		ro	U8
1: COB-ID client -> server (rx)	0x80000000	0	4294967295	rw	U32
2: COB-ID server -> client (tx)	0x80000000	0	4294967295	rw	U32
3: Node-ID of the SDO client	1 ... 127	- (read access only)		ro	U32

Setting of the identifiers for the SDO server channel 5. For description see object [I-1201](#).

### I-1205

Index: <b>I-1205</b>	Name: <b>SDO6 server parameter</b>				
Subindex	Default setting	Setting range (min. value   unit   max. value)		Access	Data type
0: Highest subindex supported	3	- (read access only)		ro	U8
1: COB-ID client -> server (rx)	0x80000000	0	4294967295	rw	U32
2: COB-ID server -> client (tx)	0x80000000	0	4294967295	rw	U32
3: Node-ID of the SDO client	1 ... 127	- (read access only)		ro	U32

Setting of the identifiers for the SDO server channel 6. For description see object [I-1201](#).

# 9 "CAN on board" system bus

## 9.10 CANopen objects implemented | I-1206

### I-1206

Index: <b>I-1206</b>	Name: <b>SDO7 server parameter</b>				
Subindex	Default setting	Setting range (min. value   unit   max. value)		Access	Data type
0: Highest subindex supported	3	- (read access only)		ro	U8
1: COB-ID client -> server (rx)	0x80000000	0	4294967295	rw	U32
2: COB-ID server -> client (tx)	0x80000000	0	4294967295	rw	U32
3: Node-ID of the SDO client	1 ... 127	- (read access only)		ro	U32

Setting of the identifiers for the SDO server channel 7. For description see object [I-1201](#).

### I-1207

Index: <b>I-1207</b>	Name: <b>SDO8 server parameter</b>				
Subindex	Default setting	Setting range (min. value   unit   max. value)		Access	Data type
0: Highest subindex supported	3	- (read access only)		ro	U8
1: COB-ID client -> server (rx)	0x80000000	0	4294967295	rw	U32
2: COB-ID server -> client (tx)	0x80000000	0	4294967295	rw	U32
3: Node-ID of the SDO client	1 ... 127	- (read access only)		ro	U32

Setting of the identifiers for the SDO server channel 8. For description see object [I-1201](#).

### I-1208

Index: <b>I-1208</b>	Name: <b>SDO9 server parameter</b>				
Subindex	Default setting	Setting range (min. value   unit   max. value)		Access	Data type
0: Highest subindex supported	3	- (read access only)		ro	U8
1: COB-ID client -> server (rx)	0x80000000	0	4294967295	rw	U32
2: COB-ID server -> client (tx)	0x80000000	0	4294967295	rw	U32
3: Node-ID of the SDO client	1 ... 127	- (read access only)		ro	U32

Setting of the identifiers for the SDO server channel 9. For description see object [I-1201](#).

### I-1209

Index: <b>I-1209</b>	Name: <b>SDO10 server parameter</b>				
Subindex	Default setting	Setting range (min. value   unit   max. value)		Access	Data type
0: Highest subindex supported	3	- (read access only)		ro	U8
1: COB-ID client -> server (rx)	0x80000000	0	4294967295	rw	U32
2: COB-ID server -> client (tx)	0x80000000	0	4294967295	rw	U32
3: Node-ID of the SDO client	1 ... 127	- (read access only)		ro	U32

Setting of the identifiers for the SDO server channel 10. For description see object [I-1201](#).

## I-1400

Index: <b>I-1400</b>	Name: <b>RPDO1 communication parameter</b>				
Subindex	Default setting	Setting range (min. value   unit   max. value)		Access	Data type
0: Highest subindex supported	5	- (read access only)		ro	U8
1: COB-ID used by RPDO	0x200 + node ID	0	4294967295	rw	U32
2: Transmission type	254	0	255	rw	U8
3: Inhibit time	-	- (not used for RPDOs)		rw	U16
4: Compatibility entry	-	- (reserved, read or write access leads to error message 0x06090011)		rw	U8
5: Event timer	-	- (not used for RPDOs)		rw	U16

Communication parameter for receiving process data via RPDO1

Subindex	Meaning	Lenze code
1	RPDO1 identifier • The basic setting is according to the "Predefined Connection Set": Identifier = 0x200 + node ID	<a href="#">C00321/1</a>
2	RPDO Transmission type according to DS301 V4.02 ▶ <a href="#">Transmission type</a> (□ 311)	<a href="#">C00323/1</a>

8th byte		7th byte		6. byte		5th byte	
Data 4		Data 3		Data 2		Data 1	
Bit 31	Bit 30	Bit 29 ... bit 11				Bit 10 ... bit 0	
0/1	0/1	Extended identifier*				11-bit identifier	
* The extended identifier is not supported. Bit 11 ... bit 29 must be set to "0".							

[9-25] Data frame assignment

Bit	setting	
Bit 30	0	RTR to this PDO possible (cannot be set).
	1	RTR to this PDO not possible (Lenze).
Bit 31	0	PDO active
	1	PDO inactive

How to change the identifier:

1. Deactivate identifier (set bit 31 to "1").
2. Change identifier.
3. Activate identifier (set bit 31 to "0").

## I-1401

Index: <b>I-1401</b>		Name: <b>RPDO2 communication parameter</b>			
Subindex	Default setting	Setting range (min. value   unit   max. value)		Access	Data type
0: Highest subindex supported	5	- (read access only)		ro	U8
1: COB-ID used by RPDO	0x300 + node ID	0		4294967295	rw U32
2: Transmission type	254	0		255	rw U8
3: Inhibit time	-	- (not used for RPDOs)		rw	U16
4: Compatibility entry	-	- (reserved, read or write access leads to error message 0x06090011)		rw	U8
5: Event timer	-	- (not used for RPDOs)		rw	U16

Communication parameter for receiving process data via RPDO2

Subindex	Meaning	Lenze code
1	RPDO2 identifier • The basic setting is according to the "Predefined Connection Set": Identifier = 0x300 + node ID	<a href="#">C00321/2</a>
2	RPDO Transmission type according to DS301 V4.02 ▶ <a href="#">Transmission type</a> (□ 311)	<a href="#">C00323/2</a>

- For assignment of the data telegram see object [I-1400](#).

## I-1402

Index: <b>I-1402</b>		Name: <b>RPDO3 communication parameter</b>			
Subindex	Default setting	Setting range (min. value   unit   max. value)		Access	Data type
0: Highest subindex supported	5	- (read access only)		ro	U8
1: COB-ID used by RPDO	0x400 + node ID	0		4294967295	rw U32
2: Transmission type	254	0		255	rw U8
3: Inhibit time	-	- (not used for RPDOs)		rw	U16
4: Compatibility entry	-	- (reserved, read or write access leads to error message 0x06090011)		rw	U8
5: Event timer	-	- (not used for RPDOs)		rw	U16

Communication parameter for receiving process data via RPDO3

Subindex	Meaning	Lenze code
1	RPDO3 identifier • The basic setting is according to the "Predefined Connection Set": Identifier = 0x400 + node ID	<a href="#">C00321/3</a>
2	RPDO Transmission type according to DS301 V4.02 ▶ <a href="#">Transmission type</a> (□ 311)	<a href="#">C00323/3</a>

- For assignment of the data telegram see object [I-1400](#).

# 9 "CAN on board" system bus

## 9.10 CANopen objects implemented | I-1403

### I-1403

Index: <b>I-1403</b>		Name: <b>RPDO4 communication parameter</b>			
Subindex	Default setting	Setting range (min. value   unit   max. value)		Access	Data type
0: Highest subindex supported	5	- (read access only)		ro	U8
1: COB-ID used by RPDO	0x500 + node ID	0		4294967295	rw U32
2: Transmission type	254	0		255	rw U8
3: Inhibit time	-	- (not used for RPDOs)		rw	U16
4: Compatibility entry	-	- (reserved, read or write access leads to error message 0x06090011)		rw	U8
5: Event timer	-	- (not used for RPDOs)		rw	U16

Communication parameter for receiving process data via RPDO4

Subindex	Meaning	Lenze code
1	Identifier RPDO4 • The basic setting is according to the "Predefined Connection Set": Identifier = 0x500 + node ID	<a href="#">C00321/4</a>
2	RPDO Transmission type according to DS301 V4.02 ▶ <a href="#">Transmission type</a> (□ 311)	<a href="#">C00323/4</a>

- For assignment of the data telegram see object [I-1400](#).

### I-1600

Index: <b>I-1600</b>		Name: <b>RPDO1 mapping parameter</b>			
Subindex	Default setting	Setting range (min. value   unit   max. value)		Access	Data type
0: Number of mapped application objects in PDO	0	0		8	rw U8
1 ... 8: application object 1 ... 8	0	0		4294967295	rw U32

The object I-1600 serves to receive parameter data as RPDO1.

Subindex	Meaning
0	Number of mapped objects
1 ... 8	Mapping entries 1 ... 8 for RPDO1

8th byte	7th byte	6. byte	5th byte
Data 4	Data 3	Data 2	Data 1
Bit 31 ... bit 16		Bit 15 ... bit 8	Bit 7 ... bit 0
Index		Subindex	Length

[9-26] Data frame assignment

IEC 61131 process data words are mapped. Only whole bytes can be mapped (the granularity of the mapping entries is one byte).



**I-1601**

Index: <b>I-1601</b>	Name: <b>RPDO2 mapping parameter</b>					
Subindex	Default setting	Setting range (min. value   unit   max. value)			Access	Data type
0: Number of mapped application objects in PDO	0	0		8	rw	U8
1 ... 8: application object 1 ... 8	0	0		4294967295	rw	U32

The object I-1601 serves to receive parameter data as RPDO2.

Subindex	Meaning
0	Number of mapped objects
1 ... 8	Mapping entries 1 ... 8 for RPDO2

- For data telegram assignment, see object [I-1600](#).

**I-1602**

Index: <b>I-1602</b>	Name: <b>RPDO3 mapping parameter</b>					
Subindex	Default setting	Setting range (min. value   unit   max. value)			Access	Data type
0: Number of mapped application objects in PDO	0	0		8	rw	U8
1 ... 8: application object 1 ... 8	0	0		4294967295	rw	U32

The object I-1602 serves to receive parameter data as RPDO3.

Subindex	Meaning
0	Number of mapped objects
1 ... 8	Mapping entries 1 ... 8 for RPDO3

- For data telegram assignment, see object [I-1600](#).

**I-1603**

Index: <b>I-1603</b>	Name: <b>RPDO4 mapping parameter</b>					
Subindex	Default setting	Setting range (min. value   unit   max. value)			Access	Data type
0: Number of mapped application objects in PDO	0	0		8	rw	U8
1 ... 8: application object 1 ... 8	0	0		4294967295	rw	U32

The object I-1603 serves to receive parameter data as RPDO4.

Subindex	Meaning
0	Number of mapped objects
1 ... 8	Mapping entries 1 ... 8 for RPDO4

- For data telegram assignment, see object [I-1600](#).

## I-1800

Index: <b>I-1800</b>	Name: <b>TPDO1 communication parameter</b>					
Subindex	Default setting	Setting range (min. value   unit   max. value)			Access	Data type
0: Highest subindex supported	5	- (read access only)			ro	U8
1: COB-ID used by TPDO	0x180 + node ID	0		4294967295	rw	U32
2: Transmission type	254	0		255	rw	U8
3: Inhibit time	0 ms	0	0.1 ms	65535	rw	U16
4: Reserved	-	- (reserved, read or write access leads to error message 0x06090011)			rw	U8
5: Event timer	0 ms	0	ms	65535	rw	U16

Communication parameter for sending process data via TPDO1

Subindex	Meaning	Lenze code
1	TPDO1 identifier • The basic setting is according to the "Predefined Connection Set": Identifier = 0x180 + node ID	<a href="#">C00320/1</a>
2	TPDO transmission type according to DS301 V4.02 ▶ <a href="#">Transmission type</a> (□ 311)	<a href="#">C00322/1</a>
3	Minimum time between sending two identical TPDOs (see DS301 V4.02).	<a href="#">C00324/1</a>
5	Cycle time for PDO transmission with transmission type "254".	<a href="#">C00356/1</a>

8th byte		7th byte		6. byte		5th byte	
Data 4		Data 3		Data 2		Data 1	
Bit 31	Bit 30	Bit 29 ... bit 11				Bit 10 ... bit 0	
0/1	0/1	Extended identifier*				11-bit identifier	
* The extended identifier is not supported. Bit 11 ... bit 29 must be set to "0".							

[9-27] Data frame assignment

Bit	setting
Bit 30	0 RTR to this PDO possible (Lenze).
	1 RTR to this PDO not possible (not adjustable)
Bit 31	0 PDO active
	1 PDO inactive

How to change the identifier:

1. Deactivate identifier (set bit 31 to "1").
2. Change identifier.
3. Activate identifier (set bit 31 to "0").

**Subindex 3 - inhibit time**

The delay time can only be changed if the PDO is inactive (subindex 1, bit 31 = 1). The entered value multiplied by 0.1 results in the delay time in [ms]. The calculated delay time is always rounded down to an integer value.

Example:

- Entered value: 26
- Calculated time =  $26 * 0.1 \text{ [ms]} = 2.6 \text{ [ms]} \rightarrow \text{delay time} = 2 \text{ [ms]}$

**I-1801**

Index: <b>I-1801</b>	Name: <b>TPDO2 communication parameter</b>					
Subindex	Default setting	Setting range (min. value   unit   max. value)			Access	Data type
0: Highest subindex supported	5	- (read access only)			ro	U8
1: COB-ID used by TPDO	0x280 + node ID	0		4294967295	rw	U32
2: Transmission type	254	0		255	rw	U8
3: Inhibit time	0 ms	0	0.1 ms	65535	rw	U16
4: Reserved	-	- (reserved, read or write access leads to error message 0x06090011)			rw	U8
5: Event timer	0 ms	0	ms	65535	rw	U16

Communication parameter for sending process data via TPDO2

Subindex	Meaning	Lenze code
1	TPDO2 identifier • The basic setting is according to the "Predefined Connection Set": Identifier = 0x280 + node ID	<a href="#">C00320/2</a>
2	TPDO transmission type according to DS301 V4.02 ▶ <a href="#">Transmission type</a> (□ 311)	<a href="#">C00322/2</a>
3	Minimum time between sending two identical TPDOs (see DS301 V4.02).	<a href="#">C00324/2</a>
5	Cycle time for PDO transmission with transmission type "254".	<a href="#">C00356/2</a>

- For assignment of the data telegram see object [I-1800](#).

## I-1802

Index: I-1802	Name: TPDO3 communication parameter				
Subindex	Default setting	Setting range (min. value   unit   max. value)		Access	Data type
0: Highest subindex supported	5	- (read access only)		ro	U8
1: COB-ID used by TPDO	0x380 + node ID	0		4294967295	rw U32
2: Transmission type	254	0		255	rw U8
3: Inhibit time	0 ms	0	0.1 ms	65535	rw U16
4: Reserved	-	- (reserved, read or write access leads to error message 0x06090011)		rw	U8
5: Event timer	0 ms	0	ms	65535	rw U16

Communication parameter for sending process data via TPDO3

Subindex	Meaning	Lenze code
1	TPDO3 identifier • The basic setting is according to the "Predefined Connection Set": Identifier = 0x380 + node ID	<a href="#">C00320/3</a>
2	TPDO transmission type according to DS301 V4.02 ▶ <a href="#">Transmission type</a> (□ 311)	<a href="#">C00322/3</a>
3	Minimum time between sending two identical TPDOs (see DS301 V4.02).	<a href="#">C00324/3</a>
5	Cycle time for PDO transmission with transmission type "254".	<a href="#">C00356/3</a>

- For assignment of the data telegram see object [I-1800](#).

## I-1803

Index: I-1803	Name: TPDO4 communication parameter				
Subindex	Default setting	Setting range (min. value   unit   max. value)		Access	Data type
0: Highest subindex supported	5	- (read access only)		ro	U8
1: COB-ID used by TPDO	0x480 + node ID	0		4294967295	rw U32
2: Transmission type	254	0		255	rw U8
3: Inhibit time	0 ms	0	0.1 ms	65535	rw U16
4: Reserved	-	- (reserved, read or write access leads to error message 0x06090011)		rw	U8
5: Event timer	0 ms	0	ms	65535	rw U16

Communication parameter for sending process data via TPDO4

Subindex	Meaning	Lenze code
1	Identifier TPDO4 • The basic setting is according to the "Predefined Connection Set": Identifier = 0x480 + node ID	<a href="#">C00320/4</a>
2	TPDO transmission type according to DS301 V4.02 ▶ <a href="#">Transmission type</a> (□ 311)	<a href="#">C00322/4</a>
3	Minimum time between sending two identical TPDOs (see DS301 V4.02).	<a href="#">C00324/4</a>
5	Cycle time for PDO transmission with transmission type "254".	<a href="#">C00356/4</a>

- For assignment of the data telegram see object [I-1800](#).

# 9 "CAN on board" system bus

## 9.10 CANopen objects implemented | I-1A00

### I-1A00

Index: <b>I-1A00</b>	Name: <b>TPDO1 mapping parameter</b>					
Subindex	Default setting	Setting range (min. value   unit   max. value)			Access	Data type
0: Number of mapped application objects in PDO	0	0		8	rw	U8
1 ... 8: application object 1 ... 8	0	0		4294967295	rw	U32

The object I-1A00 serves to send parameter data as TPDO1.

Subindex	Meaning
0	Number of mapped objects
1 ... 8	Mapping entry 1 ... 8 for TPDO1

8th byte	7th byte	6. byte	5th byte
Data 4	Data 3	Data 2	Data 1
Bit 31 ... bit 16		Bit 15 ... bit 8	
Index		Subindex	Length

[9-28] Data frame assignment

IEC 61131 process data words are mapped. Only whole bytes can be mapped (the granularity of the mapping entries is one byte).

### I-1A01

Index: <b>I-1A01</b>	Name: <b>TPDO2 mapping parameter</b>					
Subindex	Default setting	Setting range (min. value   unit   max. value)			Access	Data type
0: Number of mapped application objects in PDO	0	0		8	rw	U8
1 ... 8: application object 1 ... 8	0	0		4294967295	rw	U32

The object I-1A01 serves to send parameter data as TPDO2.

Subindex	Meaning
0	Number of mapped objects
1 ... 8	Mapping entries 1 ... 8 for RPDO2

- For assignment of the data telegram see object [I-1A00](#).

## I-1A02

Index: <b>I-1A02</b>	Name: <b>TPDO3 mapping parameter</b>					
Subindex	Default setting	Setting range (min. value   unit   max. value)			Access	Data type
0: Number of mapped application objects in PDO	0	0		8	rw	U8
1 ... 8: application object 1 ... 8	0	0		4294967295	rw	U32

The object I-1A02 serves to send parameter data as TPDO3.

Subindex	Meaning
0	Number of mapped objects
1 ... 8	Mapping entries 1 ... 8 for RPDO4

- For assignment of the data telegram see object [I-1A00](#).

## I-1A03

Index: <b>I-1A03</b>	Name: <b>TPDO4 mapping parameter</b>					
Subindex	Default setting	Setting range (min. value   unit   max. value)			Access	Data type
0: Number of mapped application objects in PDO	0	0		8	rw	U8
1 ... 8: application object 1 ... 8	0	0		4294967295	rw	U32

The object I-1A03 serves to send parameter data as TPDO4.

Subindex	Meaning
0	Number of mapped objects
1 ... 8	Mapping entries 1 ... 8 for TPDO4

- For assignment of the data telegram see object [I-1A00](#).

# 9 "CAN on board" system bus

## 9.11 System block "LS\_SyncInput"

### 9.11 System block "LS\_SyncInput"

The **LS\_SyncInput** system block provides status information in the function block editor about the sync telegram received via the system block.

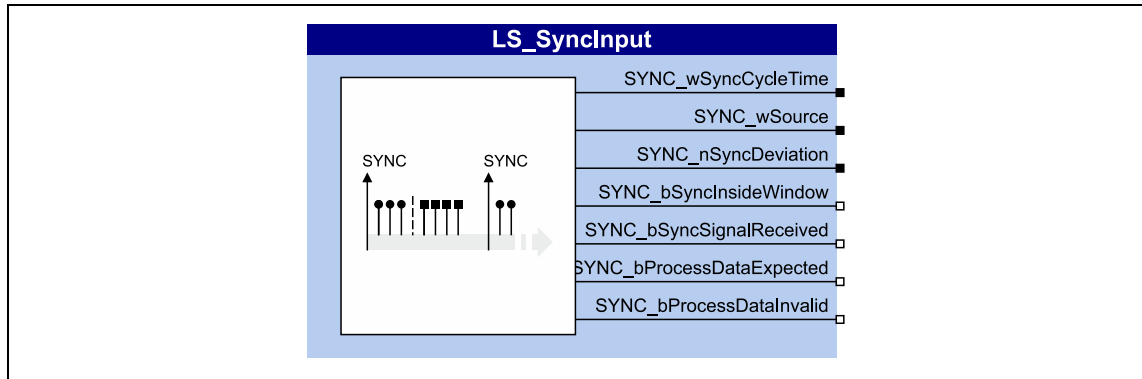

#### Outputs

Identifier	Data type	Value/meaning																										
SYNC_wSyncCycleTime	WORD	Sync cycle time in [µs] • Time with which the internal phase-locking loop (PLL) expects the synchronisation signals. The time must be set in <a href="#">C01121</a> in accordance with the cycle of the synchronisation source selected in <a href="#">C01120</a> .																										
SYNC_wSource	WORD	Synchronisation source selected in <a href="#">C01120</a> : <table border="1"> <tr><td>0</td><td>Off</td></tr> <tr><td>1</td><td>CAN on board</td></tr> <tr><td>2</td><td>CAN module</td></tr> <tr><td>4</td><td>Module in MXI1</td></tr> <tr><td>5</td><td>Module in MXI2</td></tr> <tr><td>6</td><td>Digital input 1</td></tr> <tr><td>7</td><td>Digital input 2</td></tr> <tr><td>8</td><td>Digital input 3</td></tr> <tr><td>9</td><td>Digital input 4</td></tr> <tr><td>10</td><td>Digital input 5</td></tr> <tr><td>11</td><td>Digital input 6</td></tr> <tr><td>12</td><td>Digital input 7</td></tr> <tr><td>13</td><td>Digital input 8</td></tr> </table>	0	Off	1	CAN on board	2	CAN module	4	Module in MXI1	5	Module in MXI2	6	Digital input 1	7	Digital input 2	8	Digital input 3	9	Digital input 4	10	Digital input 5	11	Digital input 6	12	Digital input 7	13	Digital input 8
0	Off																											
1	CAN on board																											
2	CAN module																											
4	Module in MXI1																											
5	Module in MXI2																											
6	Digital input 1																											
7	Digital input 2																											
8	Digital input 3																											
9	Digital input 4																											
10	Digital input 5																											
11	Digital input 6																											
12	Digital input 7																											
13	Digital input 8																											
SYNC_nSyncDeviation	INT	Deviation of the synchronisation signal in [increments] • ±16000 increments ≅ ±1 ms																										
SYNC_bSyncInsideWindow	BOOL	Status signal "Synchronisation signal within time slot" <b>Note!</b> If you use this signal in the application, observe the change in behaviour from software version V7.= onwards described in the following subchapter! ▶ <a href="#">Behaviour of the status signal bSyncInsideWindow (□ 368)</a> <table border="1"> <tr> <td>TRUE</td> <td>The last synchronisation signal has been around the expected value within the time slot parameterised in <a href="#">C01123</a>.</td> </tr> </table>	TRUE	The last synchronisation signal has been around the expected value within the time slot parameterised in <a href="#">C01123</a> .																								
TRUE	The last synchronisation signal has been around the expected value within the time slot parameterised in <a href="#">C01123</a> .																											
SYNC_bSyncSignalReceived	BOOL	Status signal "Receive synchronisation signal" <table border="1"> <tr> <td>TRUE</td> <td>Synchronisation signal has been received.</td> </tr> </table>	TRUE	Synchronisation signal has been received.																								
TRUE	Synchronisation signal has been received.																											
SYNC_bProcessDataExpected	BOOL	Status signal "Synchronous PDO expected" <table border="1"> <tr> <td>TRUE</td> <td>Synchronous PDO is expected</td> </tr> </table>	TRUE	Synchronous PDO is expected																								
TRUE	Synchronous PDO is expected																											

Identifier	Data type	Value/meaning
SYNC_bProcessDataInvalid	BOOL	Status signal "Synchronous PDO invalid"
		TRUE   Synchronous PDO is invalid.

▶ [Synchronisation of PDOs via sync telegram](#) (☰ 313)

### 9.11.1 Behaviour of the status signal `bSyncInsideWindow`

[C01123](#) serves to set a time slot for monitoring the synchronisation signal. If the synchronisation signal received via the bus is in this time slot (around the expected time of the synchronisation signal), the `bSyncInsideWindow` output is set to TRUE.

#### Up to and including software version V6.0 the following applies:

Due to an error in the implementation, the phase position set in [C01122](#) is included in the calculation of the time slot. The time slot effective for monitoring around the expected time of the synchronisation signal is thus increased by the amount of the set phase position.

Example:

- Sync phase position ([C01122](#)) = 400 µs
- Sync tolerance ([C01123](#)) = 20 µs

→ The time slot for monitoring has a size of 420 µs!

#### The following applies from software version V7.0 onwards:

The faulty inclusion of the phase position set in [C01122](#) into the calculation of the time slot has been removed. The time slot for monitoring the synchronisation signal only corresponds to the sync tolerance set in [C01123](#).

Example:

- Sync phase position ([C01122](#)) = 400 µs
- Sync tolerance ([C01123](#)) = 20 µs

→ The time slot for monitoring has a size of 20 µs!

#### Feedbacks and their remedies

If the `bSyncInsideWindow` status signal is used in existing systems, this remedy reduces the monitoring window by the amount of the phase position if it is non-zero. This may cause an unwanted activation of the monitoring of the synchronisation signal programmed by the user.

**Remedy:** When the syn tolerance is increased ([C01123](#)) by the amount of the phase position set in [C01122](#), the compatible state is restored.



### 10 Safety engineering

The controller can be equipped with a safety module. The individual safety module types have a different range of functions to optimally meet different requirements.

"Integrated safety" stands for application-oriented safety functions that can be used on machines for the protection of persons and machines.

The motion functions are furthermore executed by the controller. The safety modules monitor the reliable compliance with limit values and provide safe inputs and outputs. If limit values are exceeded, the safety modules start control functions for the fault scenario in accordance with EN 60204-1 directly in the controller.

The safety functions are suitable for applications according to IEC 61508 to SIL 3 and, depending on the module, achieve the requirements of the EN ISO 13849-1 up to control category 4 and performance level (PL) "e".



#### Note!

For detailed information about the integrated safety technology, please see the manual for the safety module.

## 10.1 Integration into the application

If a safety function is requested, the safety engineering activates a corresponding safe monitoring function. The standstill function, however, is only executed directly if the "Safe torque off" function (STO) is activated. For the other safety functions, an action of the controller is required, which is safely monitored. The implementation of the corresponding action (e.g. braking, braking to standstill, holding of the standstill position) must be carried out by the application.

### "LS\_SafetyModuleInterface" system block

For the transmission of the control and status information from the safety module to the application, the **LS\_SafetyModuleInterface** system block is provided in the function block editor of the »Engineer«. [\(□ 371\)](#)

### "LS\_Limiter" system block/basic function "Limiter"

Furthermore the **LS\_Limiter** system block which contains the basic function "[Limiter](#)" is provided in the function block editor for the connection of safety engineering to the application. [\(□ 506\)](#)

For one thing, the basic function "Limiter" provides a parameterisation interface in »Engineer« for a comfortable setting of limit positions, limited speeds, and limit values, and for another it enables the drive to be braked specifically **after request** through the safety module.

### Basic workflow

1. Activation of the safety function on the safety module (e. g. SS1 - safe stop 1).  
→ Monitoring starts.
2. The safety module informs the controller via a control word that the safety function has been activated.
3. The application evaluates the control word and starts the required motion sequence (e.g. braking).



### Note!

If communication to the controller is interrupted, e.g. by switching off the controller, the safety module responds as follows:

- Fault stop with STO is activated.
- "Warning" error message is transmitted.
- The LED "ME" is blinking.

The required error acknowledgement (AIE) is possible via terminal or safety bus.

10.2 Selecting the required safety module



**Note!**

With online communication via a bus system, there is the possibility that several users access the same drive at the same time and edit the safe parameter set.

After transferring the safe parameters, it must be checked whether the check sums (CRC) of the parameter set, memory module, and the safety module comply with each other in the *Safe Transfer* dialog box.

Access to the safety parameters by several users is currently technically unavoidable; therefore, organisational measures are required to ensure the consistency of the safety parameters.

The safety module expected by the application and the controller is selected in [C00214](#).

- In »Engineer« this setting is carried out automatically by assigning the device modules to the controller, i.e. »Engineer« automatically sets [C00214](#) according to the safety module selected.
- If the safety module set in [C00214](#) does not comply with the plugged-in safety module type, an error (fault) is triggered. The error can only be eliminated by mains switching.

Parameter   Name: <b>C00214   Required safety module</b>		Data type: UNSIGNED_8 Index: 24361 <sub>d</sub> = 5F29 <sub>h</sub>
Setting of the expected safety module		
<b>Selection list</b>		
1	SM0	
2	SM100	
4	SM300	
5	<b>SM301</b>	
<input checked="" type="checkbox"/> Read access <input checked="" type="checkbox"/> Write access <input type="checkbox"/> CINH <input type="checkbox"/> PLC STOP <input type="checkbox"/> No transfer <input type="checkbox"/> COM <input type="checkbox"/> MOT		

10.3 System block "LS\_SafetyModuleInterface"

The **LS\_SafetyModuleInterface** system block is the interface to the safety module in the function block editor.

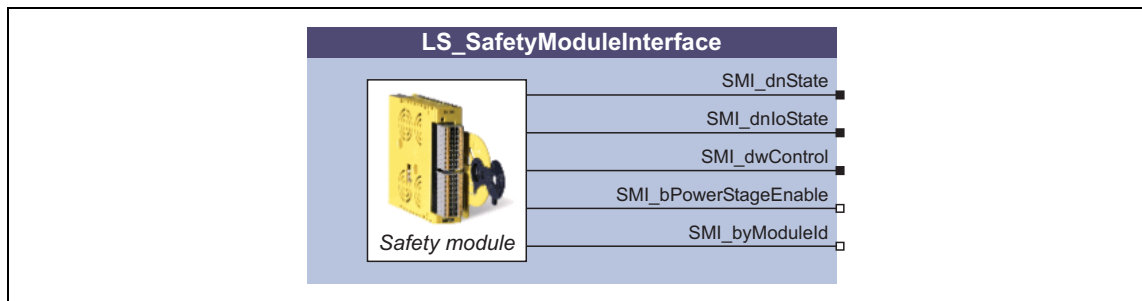

**Outputs**

Identifier	Data type	Value/meaning
SMI_dnState	DINT	Bit coded status information from the safety module ▶ <a href="#">Status information</a> (□ 373)
SMI_dnIoState	DINT	Bit coded I/O status information from the safety module ▶ <a href="#">I/O status information</a> (□ 374)
SMI_dwControl	DWORD	Bit coded control information from the safety module ▶ <a href="#">Control information</a> (□ 374)
SMI_bPowerStageEnable	BOOL	Status signal "Inverter enable"
		TRUE   Inverter is enabled by the safety module.
SMI_byModuleId	BYTE	ID of the safety module available in the controller

### 10.3.1 Status information

Via the bit-coded status signal *SMI\_dnState* of the **LS\_SafetyModuleInterface** SB, the SM3xx safety module transmits the status of safety functions to the application.

- Which bits are supported depends on the safety module used.

Bit coding of the status signal SMI_dnState		
Bit	Name	Meaning
0	STO	"Safe torque off (STO)" function is active. • The drive is safely switched to torqueless operation.
3	EC_STO	Error stop category 0: "Safe torque off (STO)" function is active.
4	EC_SS1	Error stop category 1: "Safe stop 1 (SS1)" function is active.
5	EC_SS2	Error stop category 2: "Safe stop 2 (SS2)" function is active.
8	SLS1 observed	Safely limited speed 1 is activated and complied with.
9	SLS2 observed	Safely limited speed 2 is activated and complied with.
10	SLS3 observed	Safely limited speed 3 is activated and complied with.
11	SLS4 observed	Safely limited speed 4 is activated and complied with.
12	SDIpos observed	Safe positive direction of rotation (SDIpos) is activated and complied with.
13	SDIneg observed	Safe negative direction of rotation (SDIneg) is activated and complied with.
14	Error active	SM3xx safety module has the error status (trouble or warning).

Bits not listed are reserved for future extensions!



#### Tip!

For decoding the status signal into individual boolean status signals, simply connect the *SMI\_dnState* output to the **L\_DevSMStateDecoder** FB which is available in the function library from V2.0.

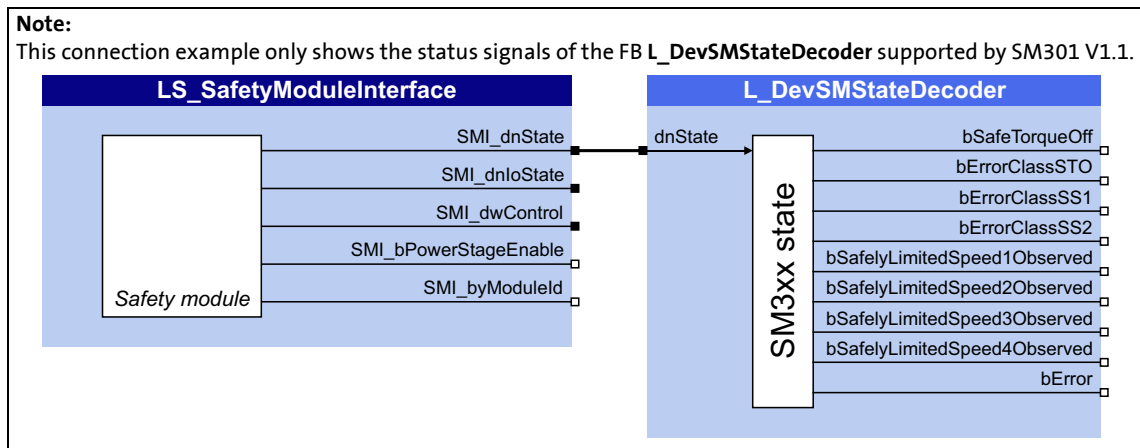

[10-1] Example: Decoding of the *SMI\_dnState* status signal into individual boolean status signals

### 10.3.2 I/O status information

Via the bit coded status signal *SMI\_dnIoState* of the **LS\_SafetyModuleInterface** SB, the SM3xx safety module transmits the status of the safe inputs and outputs to the application.

- Which bits are supported depends on the safety module used.

Bit coding of the SMI_dnIoState status signal		
Bit	Name	Meaning
0	SD-In1	Sensor input 1 in ON state.
1	SD-In2	Sensor input 2 in ON state.
2	SD-In3	Sensor input 3 in the ON state.
3	SD-In4	Sensor input 4 in the ON state.
5	AIS	Restart acknowledgement via terminal effected (negative edge: 1↘0).
6	AIE	Error acknowledgement via terminal effected (negative edge: 1↘0).
8	PS_AIS	Restart acknowledgement via safety bus effected (positive edge: 0↗1)
9	PS_AIE	Error acknowledgement via safety bus effected (positive edge: 0↗1)
12	SD-Out1	Safe output 1 (feedback output) in the ON state.

Bits not listed are reserved for future extensions!



#### Tip!

For decoding the status signal into individual boolean status signals, simply connect the *SMI\_dnIoState* output to the **L\_DevSMStateDecoderIO** FB which is available in the function library from V2.0.

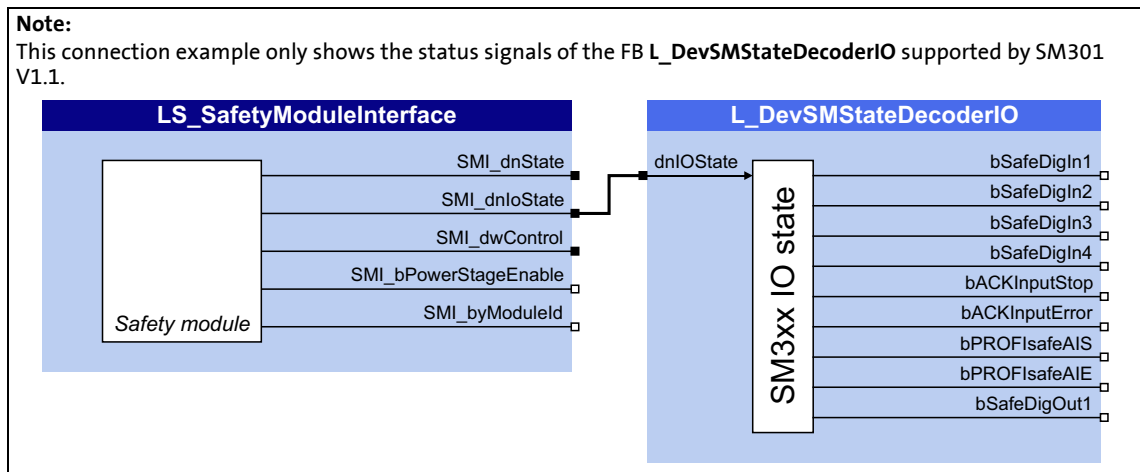

[10-2] Example: Decoding of the SMI\_dnIoState status signal into individual boolean status signals

### 10.3.3 Control information

Via the bit coded control signal *SMI\_dwControl* of the **LS\_SafetyModuleInterface** SB, the SM3xx safety module transmits information on safety functions requested, or on active safety functions to the application.

- Several safety functions can be requested/active at the same time.
- Which bits are supported depends on the safety module used.

Bit coding of the control signal <i>SMI_dwControl</i>		
Bit	Name	Meaning
1	SS1 active	"Safe stop 1 (SS1)" function is active. • After the parameterised stopping time has elapsed, bit 0 of the status signal <i>SMI_dnState</i> (STO active) is set.
2	SS2 active	"Safe stop 2 (SS2)" function is active. • After the parameterised stopping time has elapsed, bit 16 (SOS monitored) is set.
3	SLS1 active	"Safely limited speed 1 (SLS1)" function is active. • After the parameterised braking time <i>Nlim3</i> has elapsed, bit 8 of the status signal <i>SMI_dnState</i> (SLS1 monitored) is set additionally.
4	SLS2 active	"Safely limited speed 2 (SLS2)" function is active. • After the parameterised braking time <i>Nlim2</i> has elapsed, bit 9 of the status signal <i>SMI_dnState</i> (SLS2 monitored) is set additionally.
5	SLS3 active	"Safely limited speed 3 (SLS3)" function is active. • After the parameterised braking time <i>Nlim3</i> has elapsed, bit 10 of the status signal <i>SMI_dnState</i> (SLS3 monitored) is set additionally.
6	SLS4 active	"Safely limited speed 4 (SLS4)" function is active. • After the parameterised braking time has elapsed, bit 11 of the status signal <i>SMI_dnState</i> (SLS4 monitored) is additionally set.
7	SDIpos active	"Safe positive direction of rotation (SDIpos)" function is active. • After the parameterised SDI delay time has elapsed, bit 12 of the status signal <i>SMI_dnState</i> (SDIpos monitored) is set additionally.
8	SDIneg active	"Safe negative direction of rotation (SDIneg)" function is active. • After the parameterised SDI delay time has elapsed, bit 13 of the status signal <i>SMI_dnState</i> (SDIneg monitored) is set additionally.
9	ES active	"Confirm button (ES)" function for motion functions in special operation is active.
10	SLI active	"Safely limited increment (SLI)" function is active.
11	OMS	"Operation mode selector (OMS)" function for special operation has been requested.
16	SOS active	"Safe operating stop (SOS)" function is active. • The safe operating stop is monitored. • The function becomes active after the "Safe stop 2 (SS2)" function has been executed.
23	SSE active	Emergency stop function (SSE) is active. • At the end of the function, bit 1 (SS1 active) or bit 0 of the status signal <i>SMI_dnState</i> (STO active) is set according to the emergency stop function parameterised.
29	OMS active	Special operation is active.

Bits not listed are reserved for future extensions!



### Note!

To effect the corresponding action (e.g. braking to standstill, holding the standstill position), the application engineer has to provide an appropriate interconnection in the application.

- To integrate the basic function "Limiter", the output *SMI\_dwControl* is to be connected to the input *LIM\_dwControl* of the **LS\_Limiter** system block.



### Tip!

For decoding/coding the control signal, the function blocks **L\_DevSMControlDecoder** and **L\_DevSMControlEncoder** are available in the function library from V2.0.

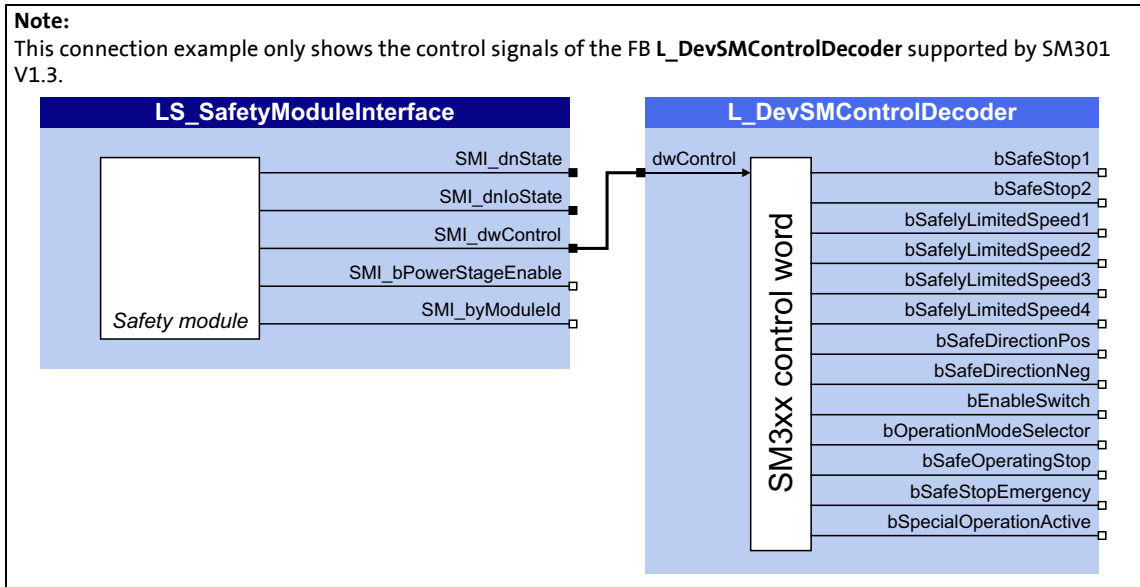

[10-3] Example: Decoding of the `SMI_dwControl` control signal into individual boolean control signals



## 11 Basic drive functions

In this chapter the basic (drive) functions of the "Servo Drives 9400" are described, to which the active application can access via defined, internal interfaces, and which can be carried out in the following way, depending on the controller type (StateLine or HighLine) and the Motion Control licence available:

### **Parameter setting by means of »Engineer« or keypad**

In each licence level the basic functions can be parameterised in »Engineer« via a corresponding dialog or alternatively via the keypad.

In the case of the 9400 StateLine (licence level Motion Control StateLevel), the interconnection of the internal interfaces is defined by the technology application selected.

### **Configuration in the »Engineer« function block editor**

»Engineer« additionally provides the graphic function block editor for the 9400 HighLine which can be used to reconfigure and extend the application interconnection by individual functions using the function library.

### **Programming according to IEC 61131-3 in »PLC Designer«\***

For the 9400 HighLine with the licence level Motion Control PLC the basic functions are also provided as separate system blocks in »PLC Designer«, which, if required, can be integrated in the control configuration, and which then can be accessed from the IEC 61131-3 program via the corresponding system variables.

\* In preparation!

# 11 Basic drive functions

## 11.1 General information

### 11.1 General information

#### 11.1.1 Internal state machine

The execution of the different basic functions is internally controlled by a state machine which can adopt the following "function states":



[11-1] Function states of the state machine "Basic functions"

The state machine ensures that:

- one basic function at a time adopts the control of the drive.
- only the basic function with the highest priority (= smallest number) is executed if several basic functions are activated at the same time. ▶ [Priorities](#) (383)
- the drive always has a defined state both in case of error and in normal operation.



**Note!**

The basic functions "[Limiter](#)" and "[Brake control](#)" run autonomously, but are able to control the state machine to a certain function state, if required.

The function states are not to be confused with the device states ("Operation", "Fault active", "Device is switched on", etc.) of the controller. ▶ [Device states](#) (100)

From software version V7.0 onwards, the basic functions "[Manual jog, encoderless](#)" and "[Pole position identification](#)" are additionally available for the setting-up operation. Both basic functions can only be requested when the controller is inhibited and with the "Controller not ready" function state:

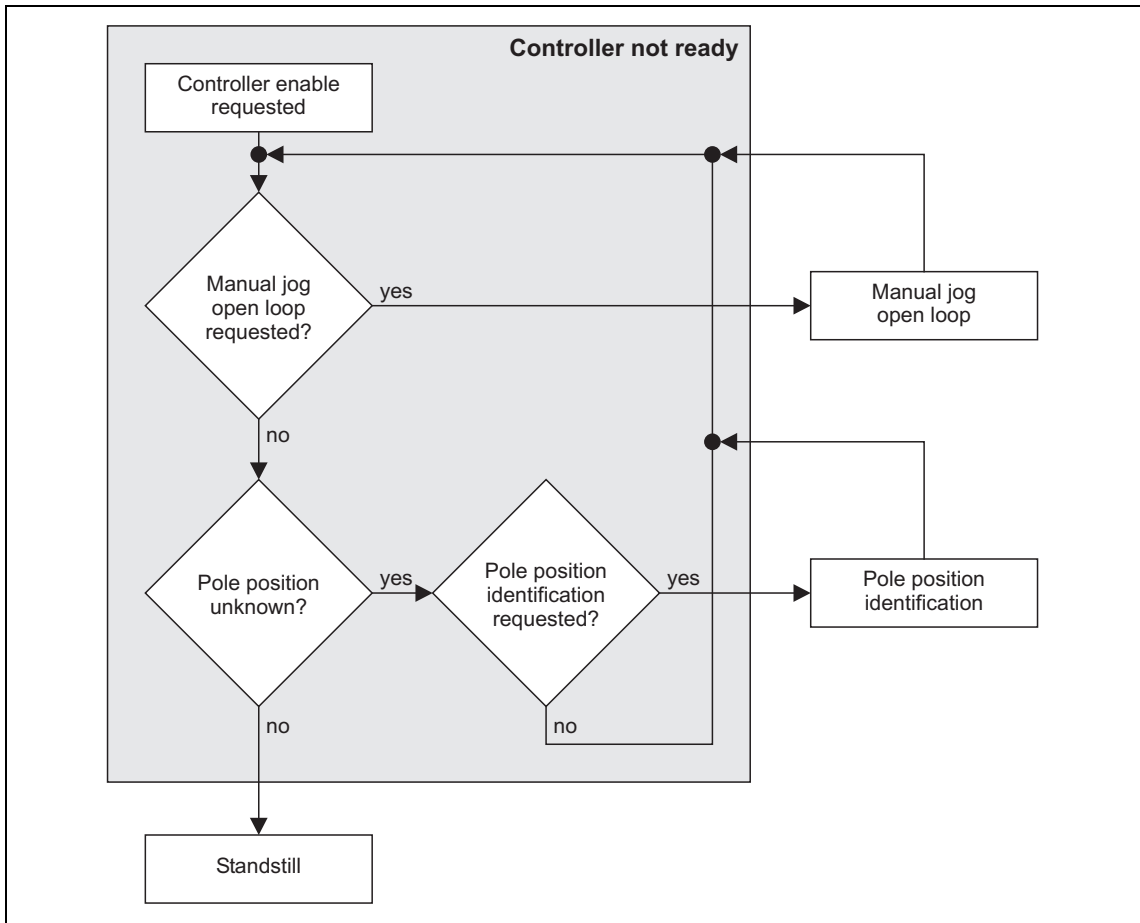

[11-2] Sequence diagram for basic functions "[Manual jog, encoderless](#)" and "[Pole position identification](#)"

### 11.1.2 Function states

**Tip!**

In [C02530](#) the currently active function state is displayed.

**"Initialisation" state**

If the controller has completed the device initialisation, the function state "Initialisation" is passed through automatically.

- In the "Initialisation" function state, the process data required for processing the basic functions are initialised.
- The monitoring functions are not active yet.
- The basic functions are not yet processed (e.g. brake control) and cannot yet be parameterised or activated either.
- If the initialisation of the basic functions is completed and no fault is available, a change-over to the basic state "Drive at standstill" is automatically effected.

**State "Controller not ready"**

In this function state the pulse inhibit is set in the controller, which means that the power output stages are high-resistance and the drive cannot be controlled.

**State "Manual jog, encoderless active"**

From software version V7.0 onwards, the drive can be controlled without feedback (encoderless) in this function state, e.g. for a setting-up operation or in the event of service when the feedback system fails. ▶ [Manual job, encoderless](#) (□ 412)

**State "Identification of pole position active"**

From software version V7.0 onwards, an identification of pole position can be executed in this function state in order to detect the pole position for the motor encoder that is currently activated in [C00495](#). ▶ [Pole position identification](#) (□ 575)

**State "Drive at standstill"**

This "basic state" is automatically adopted if no other state is active.

- The setpoints for speed and acceleration are set to "0".
- The drive is position-controlled.
- No error has occurred and quick stop is not active.
- Every basic function can be activated out of this state.

**State "Drive is stopped"**

This function state is automatically passed through when a basic function is deactivated.

- If the drive is not yet in the standstill state, it is decelerated to standstill via a parameterisable deceleration ramp.
- If a basic function is activated during the "stopping" process, this basic function takes over the control of the drive from the current speed on and the function state "Drive is stopped" is abandoned.
- If the drive is at standstill, a change-over to the basic state "Drive at standstill" is automatically effected.

**State "Manual jog active"**

In this function state, the drive can be operated manually clockwise or anti-clockwise ("Manual jog, encoderless"). ▶ [Manual jog](#) (☞ 400)

- If the home position is known to the controller, the software limit positions set and a potentially connected travel range limit switch are monitored.
- "Retracting" from an activated travel range limit switch is also possible.

**State "Homing active"**

In this function state the home position and the machine measuring system for the drive can be determined. ▶ [Homing](#) (☞ 421)

- The home position can be specified by an active homing or by reference setting.
- A redetermination of the home position is only required in case of recommissioning or in case of service (e.g. when drive components are exchanged) or after travel commands have been executed which reset the reference.

**State "Positioning active"**

In this function state all positioning types (absolute, relative, modulo, continuous, touch probe etc.) can be executed. ▶ [Positioning](#) (☞ 479)

- In the position-controlled mode, the drive executes a time-controlled point-to-point setpoint generation based on the defined motion profile.

**State "Setpoint follower active"**

In this function state the drive directly follows the defined setpoint.

- The setpoint can be optionally defined as speed, torque, or position via three separate basic functions:
  - [Speed follower](#) (☞ 496)
  - [Torque follower](#) (☞ 501)
  - [Position follower](#) (☞ 490)

**State "Quick stop active"**

This function state is active if quick stop has been activated by the user. ▶ [Quick stop](#) (📖 393)

- The drive is brought to standstill within the deceleration time parameterised, irrespective of the setpoint defined.
- If the quick stop is cancelled again by the user, a change-over to a setpoint-generating basic function (e. g. "Speed follower") is effected, if requested.

**Note!**

**For the encoderless motor control types (from software version V3.0) the following applies:**

The "Quick stop active" function state is also activated when DC-injection braking is executed.

**Tip!**

Quick stop can also be set as error response for many monitoring functions ("quick stop by trouble"). Detailed information can be found in the chapter "Diagnostics & fault analysis".

The source that activated quick stop is displayed bit-coded in [C00159](#).

**"Error" status**

This function state is active if a fault has occurred and the controller is in the "Fault active" or "Quick stop by trouble active" device state.

- The function state can only be abandoned by acknowledging the error if the error is removed.

**11.1.3 Interrupting/replacing states**

An active function state cannot be interrupted or replaced by the activation of another function state. However, the following exceptions apply:

- The "Initialisation" state replaces all other states.
- The "Fault" state can replace all other states except "Initialisation".
- The "Controller not ready" state can replace all other states except "Error" and "Initialisation".
- The "Quick stop active" state can replace all other states except "Initialisation", "Error" and "Controller not ready".

#### 11.1.4 Priorities

The function states are assigned to priorities so that, if several basic functions are activated at the same time, it is always changed to the function state with the highest priority:

Priority	Function state	Executable basic function
1	Initialisation	-
2	Error	-
3	Controller is not ready	-
4	Quick stop active	▶ <a href="#">Quick stop</a> (☞ 393)
5	Manual jog active	▶ <a href="#">Manual jog</a> (☞ 400)
6	Homing active	▶ <a href="#">Homing</a> (☞ 421)
7	Positioning active	▶ <a href="#">Positioning</a> (☞ 479)
8	Setpoint follower (position) active	▶ <a href="#">Position follower</a> (☞ 490)
9	Setpoint follower (speed) active	▶ <a href="#">Speed follower</a> (☞ 496)
10	Setpoint follower (torque) active	▶ <a href="#">Torque follower</a> (☞ 501)
10	Brake check	▶ <a href="#">Brake control</a> (☞ 521)
12	Drive is stopped	▶ <a href="#">Stop</a> (☞ 389)
13	Manual jog, encoderless active	▶ <a href="#">Manual job, encoderless</a> (☞ 412)
14	Pole position identification active	▶ <a href="#">Pole position identification</a> (☞ 575)

1 = highest priority; 14 = lowest priority



#### Note!

The basic state "Drive at standstill" is automatically adopted if no other state is active.

### 11.1.5 Requesting control via a basic function

#### Enable input "bEnable"

The basic functions "[Manual jog](#)", "[Homing](#)" and "[Positioning](#)" and the three setpoint followers each possess an *bEnable* enable input, via which the control of the corresponding basic function can be requested.

- If no other basic function and no error status is active, a change-over to the corresponding function state is effected, and the basic function can be controlled now.
- If several enable inputs are set to TRUE at the same time, the change-over to the function state is effected with the highest priority.

#### Status outputs "bEnabled", "bActive" and "bDone"

If the basic function is enabled, the *bEnabled* status output of the basic function is set to TRUE and the corresponding drive motion can be started via the control inputs of the basic function.

- If the basic function is currently carrying out a drive movement, this is shown by a TRUE signal at the status output *bActive*.
- The basic functions "[Speed follower](#)", "[Torque follower](#)", and "[Position follower](#)" are only provided with the status output *bEnabled*, as the drive directly follows the setpoint selection after being enabled.
- The basic functions "[Homing](#)" and "[Positioning](#)" are furthermore provided with a status output *bDone* showing that the drive movement started (Homing or positioning) has been completed.

Priority	Basic function	Status outputs		
		<i>bEnabled</i>	<i>bActive</i>	<i>bDone</i>
1	<a href="#">Manual jog</a>	☑	☑	
2	<a href="#">Homing</a>	☑	☑	☑
3	<a href="#">Positioning</a>	☑	☑	☑
4	<a href="#">Speed follower</a>	☑		
5	<a href="#">Torque follower</a>	☑		
6	<a href="#">Position follower</a>	☑		

#### Re-deactivating the enable of a basic function

When the *bEnable* enable input of the active basic function is reset to FALSE, the control inputs of the basic function are inhibited and the status outputs *bEnabled*, *bActive* and *bDone* are reset to FALSE.

- If the drive is not at standstill, it is brought to standstill within the deceleration time for [Stop](#) if no other basic function takes over the control of the drive. Here a change-over from the active function state via the function state "Drive is stopped" back to the basic state "Drive at standstill" is effected.
- When the enable input of another basic function is set to TRUE, this basic function adopts the control of the drive immediately.



### 11.1.6 Start acceleration/acceleration reduction when the basic function changes

In order to make the transitions during the changeover between the single basic functions as jerk-free as possible, i.e. preventing acceleration steps, the current setpoint acceleration is used as starting value for the new basic function (see the following table).

from	to						
	Position, speed or torque follower	Manual jog	Homing	Positioning	Error/controller not ready	Stop	Quick stop*
<a href="#">Position follower</a>	0	A	A	A	0	A	0
<a href="#">Speed follower</a>	0	A	A	A	0	A	0
<a href="#">Torque follower</a>	0	0	0	0	0	0	0
<a href="#">Manual jog</a>	0	-	B	B	0	B	0
<a href="#">Homing</a>	0	B	-	B	0	B	0
<a href="#">Positioning</a>	0	B	B	-	0	B	0
Error/controller not ready	0	0	0	0	-	0	0
<a href="#">Stop</a>	0	B	B	B	0	-	0
<a href="#">Quick stop*</a>	0	A	A	A	0	A	-

**Legend:**

0	The start acceleration is defined with "0", thus no acceleration reduction is required.
A	<ul style="list-style-type: none"> <li>Acceleration value is generated from the differentiation and filtering (<a href="#">C02562</a>) of the active setpoint speed.</li> <li>Jerk = Maximum value from transition jerk (defined via <a href="#">C02545</a>) and jerk of the "new" profile data.</li> </ul>
B	<ul style="list-style-type: none"> <li>Acceleration value is taken from the setpoint generator (e.g. profile generator).</li> <li>Jerk = maximum value from the jerk of the "old" and "new" profile data.</li> </ul>

\* Also quick stop by trouble

#### Reduction of the start acceleration

Depending on the acceleration and S-ramp time parameterised in the basic function, the start acceleration is reduced.

The following applies for software versions lower than V7.0:

- The start acceleration is reduced with the maximum jerk of the old or new basic function. ▶ [Setting the S-ramp time](#) (□ 387)



#### Note!

Very low jerks cause very high speeds!

See also the following chapter "[Setting the S-ramp time](#)". (□ 387)

Since this behaviour is mostly not wanted or expected, the acceleration is reduced from software version V7.0 as described in the following section.

The following applies from software version V7.0 onwards:

- The start acceleration is reduced with the maximum jerk of the old or new basic function.

#### Transition of a profile-generating to a profile-generating basic function

The corresponding jerk results from the profile data:

$$\text{Jerk} = \frac{\text{Profile acceleration/deceleration}}{\text{S-ramp time}}$$

#### Transition of a non-profile-generating to a profile-generating basic function

- The jerk of the profile-generating basic function results from the profile data:

$$\text{Jerk} = \frac{\text{Profile acceleration/deceleration}}{\text{S-ramp time}}$$

- Since a non-profile-generating basic function has no defined jerk, a "transition jerk" is used which results from the reference acceleration and the reference S-ramp time parameterised in [C02545](#).

$$\text{Transition jerk} = \frac{\text{Reference acceleration}}{\text{Reference Jerktime}} = \frac{\text{C00011} / 1 \text{ ms}}{\text{C02545} \times 10}$$

- With a Lenze setting [C02545](#) = 0.001 s, a maximum jerk occurs, i.g. the start acceleration is reduced in one cycle (1 ms).
- The setting [C02545](#) = 0.000 s results in a compatible behaviour lower than V7.0.



#### Tip!

Profile-generating basic functions are:

"[Stop](#)", "[Manual jog](#)", "[Homing](#)", "[Positioning](#)"

Non-profile-generating basic functions are:

"[Quick stop](#)", "[Position follower](#)", "[Speed follower](#)", "[Torque follower](#)"

# 11 Basic drive functions

## 11.1 General information

---

### 11.1.7 Setting the S-ramp time

For path planning, various basic functions serve to build up or reduce the acceleration linearly. The motion profile causes less structural vibrations and the gearboxes are protected.

The smoothing (jerk) is calculated via the S-ramp time and the maximum acceleration permitted in the profile:

$$\text{Jerk} = \frac{\text{maximum acceleration}}{\text{S-ramp time}}$$

[11-3] Formula for calculating the jerk for acceleration and deceleration phases

S-ramp times can be set in the given parameters for the following basic functions:

Basic function	Parameter for S-ramp time
<a href="#">Stop</a>	<a href="#">C02611</a>
<a href="#">Quick stop</a>	<a href="#">C00106</a>
<a href="#">Manual jog</a>	<a href="#">C02624</a>
<a href="#">Homing</a>	<a href="#">C02648</a>
<a href="#">Positioning</a>	The S-ramp time is defined via FB L_PosPositionerTable or FB L_PosProfileTable.



#### Stop!

When it is switched to another basic function, the start acceleration is reduced with the jerk of the new basic function. **A small jerk causes very high speeds!**

**Remedy:** Avoid unnecessarily long S-ramp times. Set the profile parameters of the different basic functions so that the jerk is roughly the same for all basic functions.

Examples

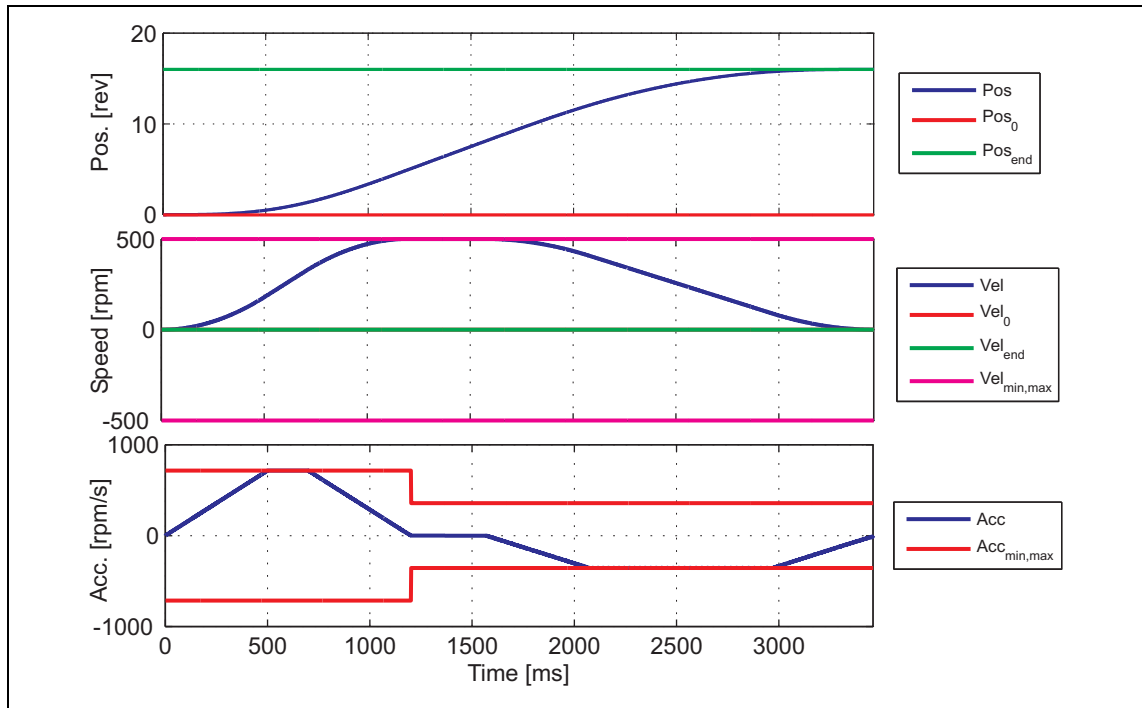

[11-4] Example 1: Point-to-point positioning from standstill without start acceleration

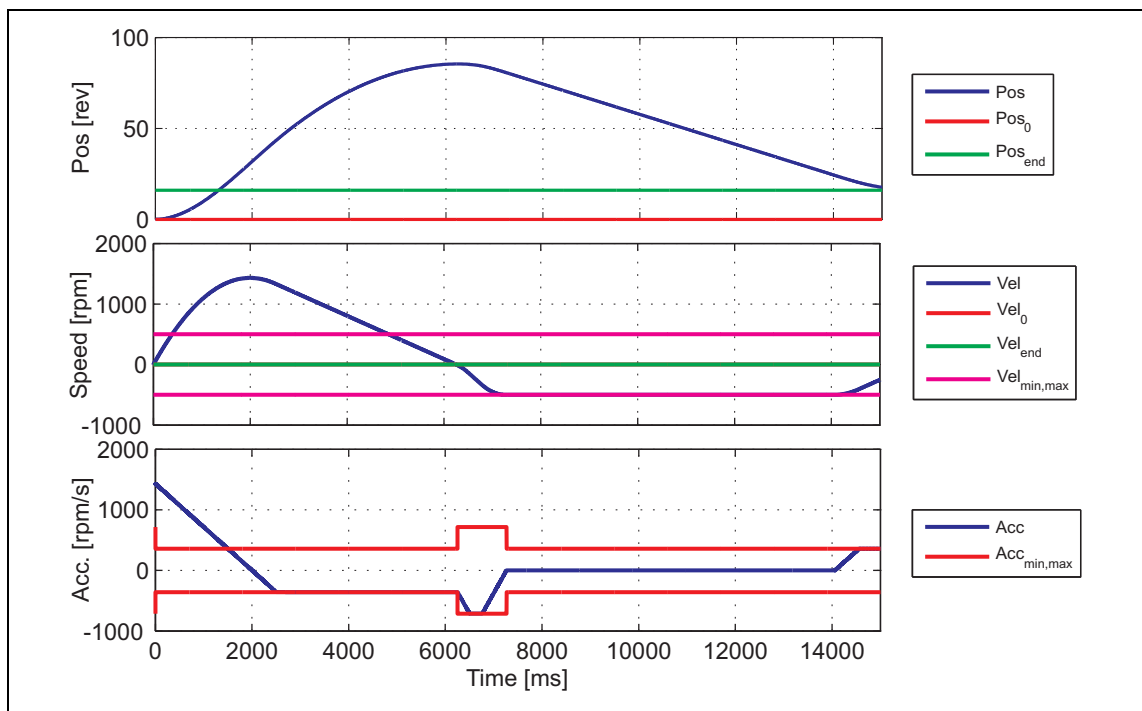

[11-5] Example 2: Point-to-point positioning from standstill with start acceleration

In the example 2, the slow reduction of the start acceleration results in very high speeds!

### 11.2 Stop

The standard stop (in the following called "stop") of the drive will be automatically activated by the internal state machine if a basic function is deactivated and the drive is not yet at standstill.

- The drive is decelerated to standstill along a parameterised deceleration ramp
  - While the drive is braked to standstill, the state machine is in the "Drive is stopped" function state.
  - If meanwhile another basic function is activated, this basic function takes over the control of the drive from the current speed on and the function state "Drive is stopped" is abandoned.
  - If the drive is at standstill, a change-over to the basic state "Drive at standstill" is automatically effected.
- An acceleration phase active at the time of activated stopping process is considered by the normal stop, i.e. the current acceleration is first lead to "0" with the parameterised S-ramp time before the real deceleration process starts.
- If the controller is enabled with the shaft coasting (controller inhibit and pulse inhibit are deactivated), the drive is lead to standstill from the current speed.



#### Stop!

The basic functions "[Speed follower](#)", "[Torque follower](#)", and "[Position follower](#)" do not take over the control of the from the current speed, but immediately with the setpoint defined, which may cause a jerk!



#### Note!

- As the stop function takes into account the acceleration active at the moment of activation, the deceleration of the stop function should always be set greater than the deceleration of the active process in order to avoid a possible overshoot.
  - If the stop function is activated while the basic function "[Torque follower](#)" or the states "Controller inhibited" or "Error" are active, the drive is braked to standstill starting from the current speed and without taking into account the current acceleration.
- ▶ [Start acceleration/acceleration reduction when the basic function changes](#) (📖 385)

### 11.2.1 Internal interfaces | "LS\_Stop" system block

The **LS\_Stop** system block provides the internal interfaces for the basic function "Stop" in the function block editor.

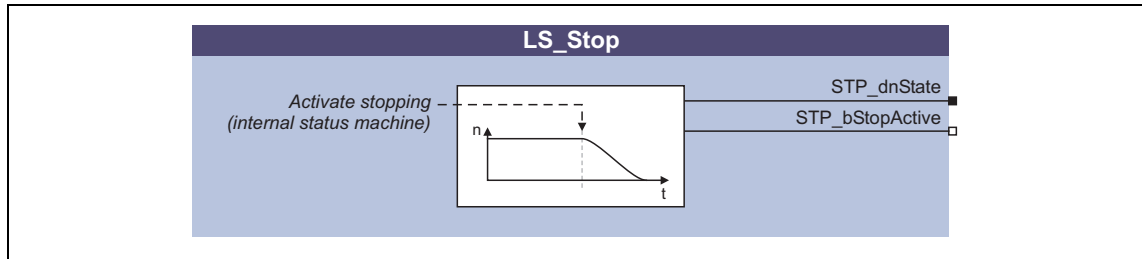

#### Note!

Ensure that the system block is called in a cyclic application task.

Basically, projects which only contain an unsolicited task and no cyclic task are not permissible!

#### Outputs

Identifier <small>DIS code   data type</small>	Value/meaning
STP_dnState <small><a href="#">C02616</a>   DINT</small>	Status (bit coded) <ul style="list-style-type: none"> <li>When the basic function is not active, all bits are set to "0".</li> <li>Bits which are not listed are not assigned with a status (always "0").</li> </ul>
	Bit 1 Drive is braked to standstill. <ul style="list-style-type: none"> <li>The internal state machine is in the "Drive is stopped" function state.</li> </ul>
	Bit 2 Drive is at standstill. <ul style="list-style-type: none"> <li>The internal state machine is in the "Drive at standstill" function state.</li> </ul>
	Bit 3 Deceleration phase is active.
	Bit 5 CCW rotation is active.
STP_bStopActive <small><a href="#">C02617</a>   BOOL</small>	Status signal "Stop is active"
	TRUE The drive is braked to standstill or is at standstill. <ul style="list-style-type: none"> <li>The internal state machine is in the "Drive is stopped" or "Drive at standstill" function state.</li> </ul>

### 11.2.2 Parameter setting

- Parameterisation dialog in »Engineer«: Tab **Application parameter** → Dialog level *Overview* → *All basic functions* → *Stop*
- Short overview of parameters for standard stop :

Parameters	Info
<a href="#">C02610</a>	Deceleration time for stop
<a href="#">C02611</a>	S-ramp time for stop
<a href="#">C02612</a>	Ref. for decel. time of stop

#### Parameter setting of stop

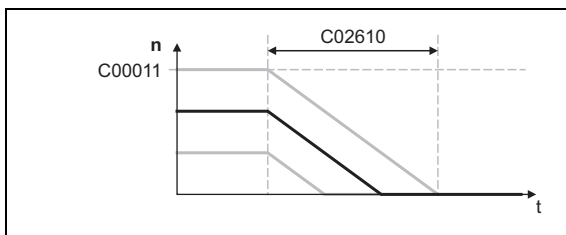

[11-6] Deceleration time referred to the motor reference speed

- The deceleration time for stop set in [C02610](#) refers to a speed variation from the motor reference speed ([C00011](#)) to standstill, i. e. the deceleration is constant.

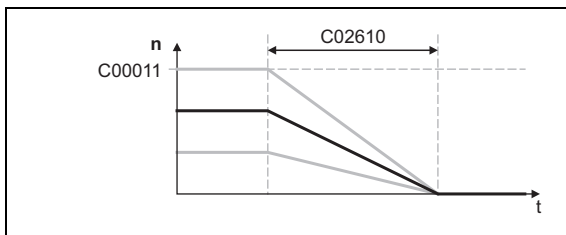

[11-7] Deceleration time referred to the current speed

- When [C02612](#) is set = "1", the deceleration time refers to the current speed, i. e. the braking time is constant.

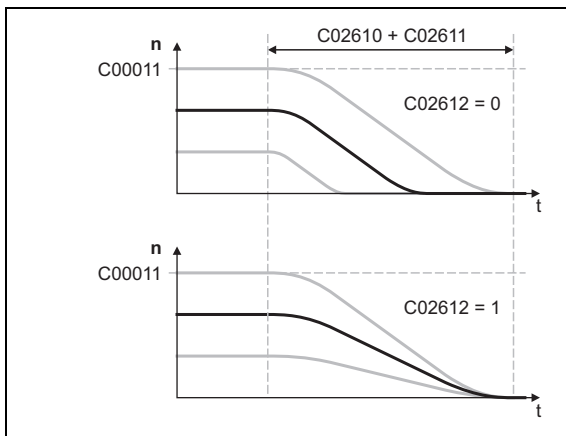

[11-8] S-shaped deceleration ramp through selection of a relative S-ramp time

- By entering an S-ramp time in [C02611](#), the deceleration ramp can be set in an S-shaped manner for purposes of jerk limitation; the total time until standstill is then extended by the S-ramp time set. ▶ [Setting the S-ramp time](#) (□ 387)
- Braking time at motor reference speed or [C02612](#) = "1":

$$C02610 [s] + C02611 [s]$$

### 11.2.3 Behaviour of the function (example)

In the following example the enable of manual jog is deactivated during an active manual jog. Then the drive is braked to standstill within the deceleration time ❶ set for stop.

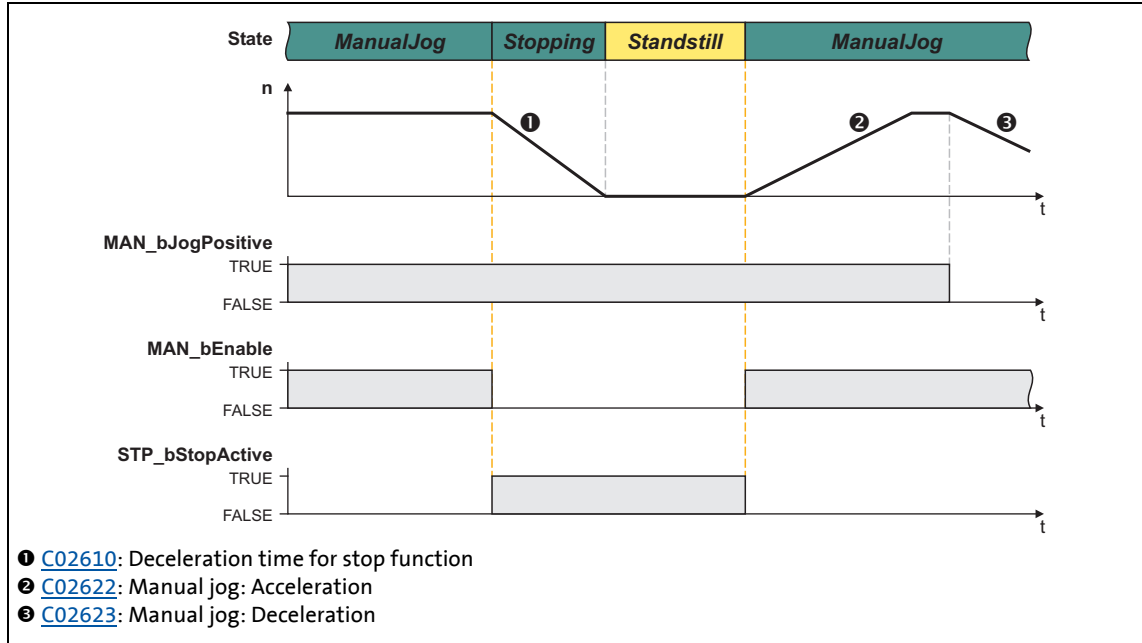

[11-9] Example: Stop with reaching standstill

If the basic function "Manual Jog" is reactivated within the deceleration time ❶, this basic function takes over the control of the drive from the current speed and the function state "Drive is stopped" is abandoned immediately:

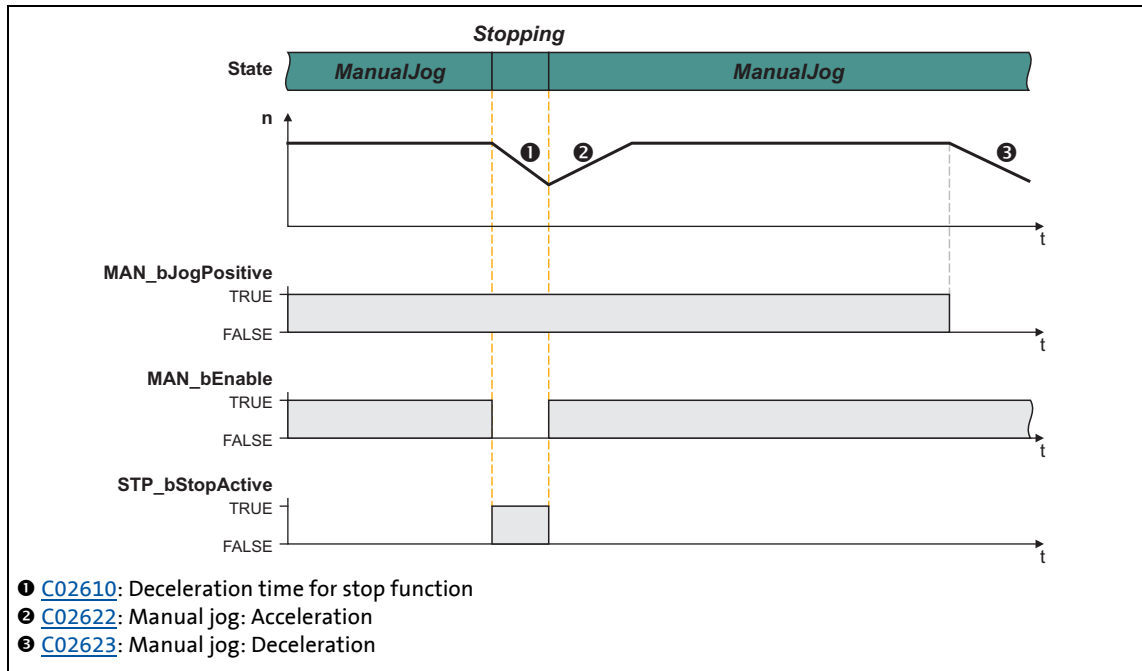

[11-10] Example: Stop without reaching standstill



# 11 Basic drive functions

## 11.3 Quick stop

### 11.3 Quick stop

In contrast to [Stop](#), the purpose of quick stop (QSP) is a stop in case of error. If quick stop is activated, the drive is brought to standstill within the deceleration time set irrespective of the setpoint that is preselected.



#### Note!

Through this, superimposed controls (e.g. synchronous or position control) may produce following errors. If several drives execute a coordinated motion, the quick stop function should only be used for the motion master (master drive) in order to maintain the coordination.

When the basic function is activated, a start acceleration is considered. ▶ [Start acceleration/acceleration reduction when the basic function changes](#) (📖 385)



#### Tip!

Quick stop can also be set as error response for many monitoring functions ("quick stop by trouble"). Detailed information can be found in the chapter "[Diagnostics & fault analysis](#)". (📖 608)

The source that activated quick stop is displayed bit-coded in [C00159](#).

#### 11.3.1 Internal interfaces | "LS\_Quickstop" system block

The **LS\_Quickstop** system block provides the internal interfaces for the basic function "Stop" in the function block editor.

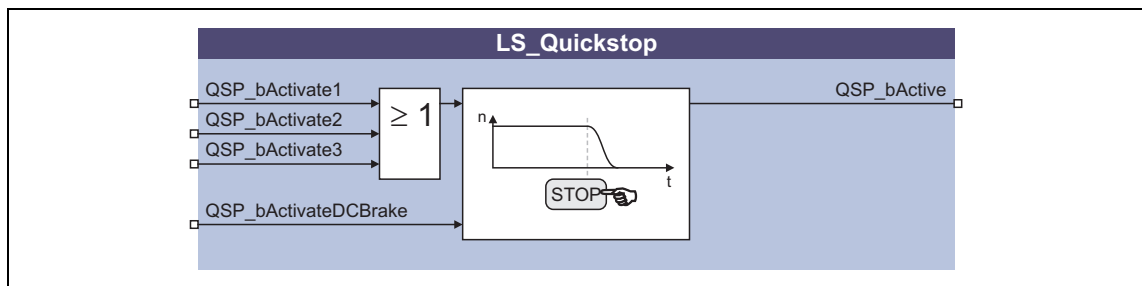

#### Note!

Ensure that the system block is called in a cyclic application task.

Basically, projects which only contain an unsolicited task and no cyclic task are not permissible!

## Inputs

Identifier DIS code   data type	Information/possible settings	
QSP_bActivate1 <a href="#">C02619/1</a>   BOOL	Activate quick stop <ul style="list-style-type: none"> <li>The three inputs are linked via a logic OR gate.</li> </ul>	
QSP_bActivate2 <a href="#">C02619/2</a>   BOOL		TRUE
QSP_bActivate3 <a href="#">C02619/3</a>   BOOL		TRUE↯FALSE
QSP_bActivateDCBrake <a href="#">C02619/5</a>   BOOL From V3.0	Activate <a href="#">DC-injection braking</a> . (☰ 397) <ul style="list-style-type: none"> <li>Only possible if V/f control or sensorless vector control is selected as motor control type in <a href="#">C00006</a>!</li> <li>This input has a higher priority than the three inputs <i>QSP_bActivate1 ... 3</i>.</li> </ul>	
	TRUE	A change-over to the "Quick stop active" function state is effected and the drive is decelerated with the braking current set in <a href="#">C00974</a> .
	TRUE↯FALSE	DC-injection braking is activated again. <ul style="list-style-type: none"> <li>If flying restart is activated in <a href="#">C00990</a>, a flying restart process is automatically started to determine the current motor speed.</li> </ul>

## Outputs

Identifier DIS code   data type	Value/meaning	
QSP_bActive <a href="#">C02619/4</a>   BOOL	Status signal "Quick stop through application active" <ul style="list-style-type: none"> <li><i>QSP_bActive</i> is not set to TRUE if quick stop has been activated by another source, e. g. via device command or as an error response ("Quick stop by trouble").</li> </ul>	
	TRUE	Quick stop has been requested via one of the three inputs <i>QSP_bActivate1 ... 3</i> and is active. - or - <a href="#">DC-injection braking</a> has been requested via <i>QSP_bActivateDCBrake</i> and is active (only for motor control mode without encoder).

## 11.3.2

## Parameter setting

- Parameterisation dialog in »Engineer«: Tab **Application parameter** → Dialog level *Overview* → *All basic functions* → *Quick stop*
- Short overview of the parameters for quick stop:

Parameters	Info
<a href="#">C00105</a>	Decel. time - quick stop
<a href="#">C00106</a>	Quick stop S-ramp time
<a href="#">C00107</a>	Reference for quick stop deceleration time

Parameter setting of quick stop

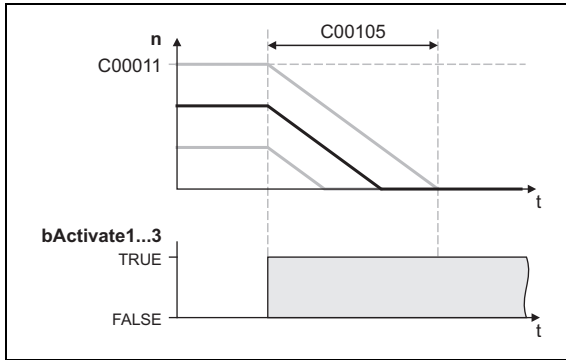

[11-11] Deceleration time referred to the motor reference speed

- The deceleration time for the quick stop function set in [C00105](#) refers to a speed variation from the motor reference speed ([C00011](#)) to standstill.

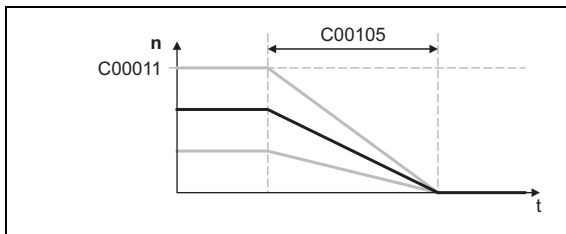

[11-12] Deceleration time referred to the current speed

- When [C00107](#) is set = "1", the deceleration time refers to the current speed.

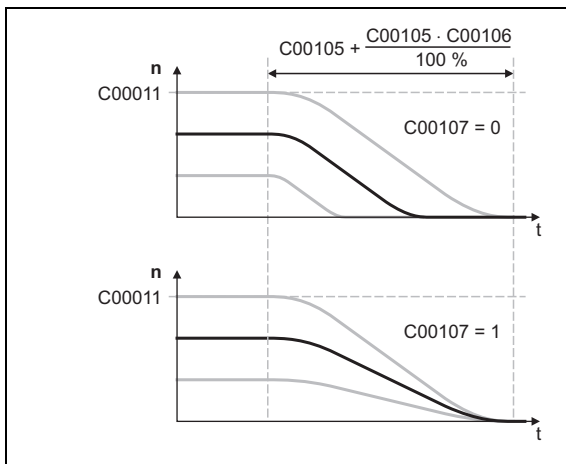

[11-13] S-shaped deceleration ramp through selection of a relative S-ramp time

- By entering a relative S-ramp time in [C00106](#), the deceleration ramp can be set in an S-shaped manner for purposes of jerk limitation; the total time until standstill is then extended by the S-ramp time set. ▶ [Setting the S-ramp time](#) (387)

- Braking time at motor reference speed or [C00107](#) = "1":

$$C00105 + \frac{C00105 \cdot C00106 [\%]}{100 \%}$$



Tip!

After reaching standstill, the standstill position can be maintained while a torque is applied.

- For this purpose, select the phase controller gain in [C00254](#) > "0".
- With [C00254](#) > "0" the phase control is automatically activated after the standstill is reached.

### 11.3.3 Activate/deactivate quick stop

For activation/deactivation of quick stop by the application, the three inputs *QSP\_bActivate1...3* are provided. ([📖 393](#))

- The three control inputs are linked via a logic OR gate, i.e. in order to activate quick stop, only one of the three inputs must be set to TRUE. To deactivate quick stop, though, all three inputs must be reset to FALSE.
- The control inputs can be linked with terminals (digital inputs) and/or process data in the function block editor.



#### Note!

In the standard technology applications the control input *QSP\_bActivate1* is linked with the digital input DI1 in the Lenze setting.

#### Further options for activating quick stop

- Via device command "Activate quick stop" ([C00002](#) = "45"), e.g. via a corresponding SDO of a higher-level control, an HMI or »Engineer«.
- Via the  key at the keypad, unless the Lenze setting of [C00469](#) (assignment of the key) has been changed.
- Through the response "quick stop by trouble" parameterised for monitoring.

# 11 Basic drive functions

## 11.3 Quick stop

---

### 11.3.4 DC-injection braking

This function extension is available from software version V3.0!

---



#### Note!

DC-injection braking is only possible if V/f control or sensorless vector control is selected as motor control type in [C00006](#)!

#### Activate DC-injection braking

To activate DC-injection braking through the application, the *bActivateDCBrake* control input must be set to TRUE.

- A change-over to the "Quick stop active" function state is effected and DC-injection braking with the braking current set in [C00974](#) is carried out.

#### Flying restart process after cancelling DC injection braking

If the flying restart mode is activated in [C00990](#) and DC-injection braking is cancelled, a flying restart process is automatically started to determine the current motor speed if the following conditions are met:

- V/f control or sensorless vector control are selected as motor control in [C00006](#).
- The position control structure is set to "Phase controller is active" in [C02570](#).
- The *MI\_bFlyingSyncBlocked* control input of the motor interface is not assigned or set to FALSE.
- The holding brake, if available, is not applied.

### 11.3.4.1 DC-injection braking and flying restart process

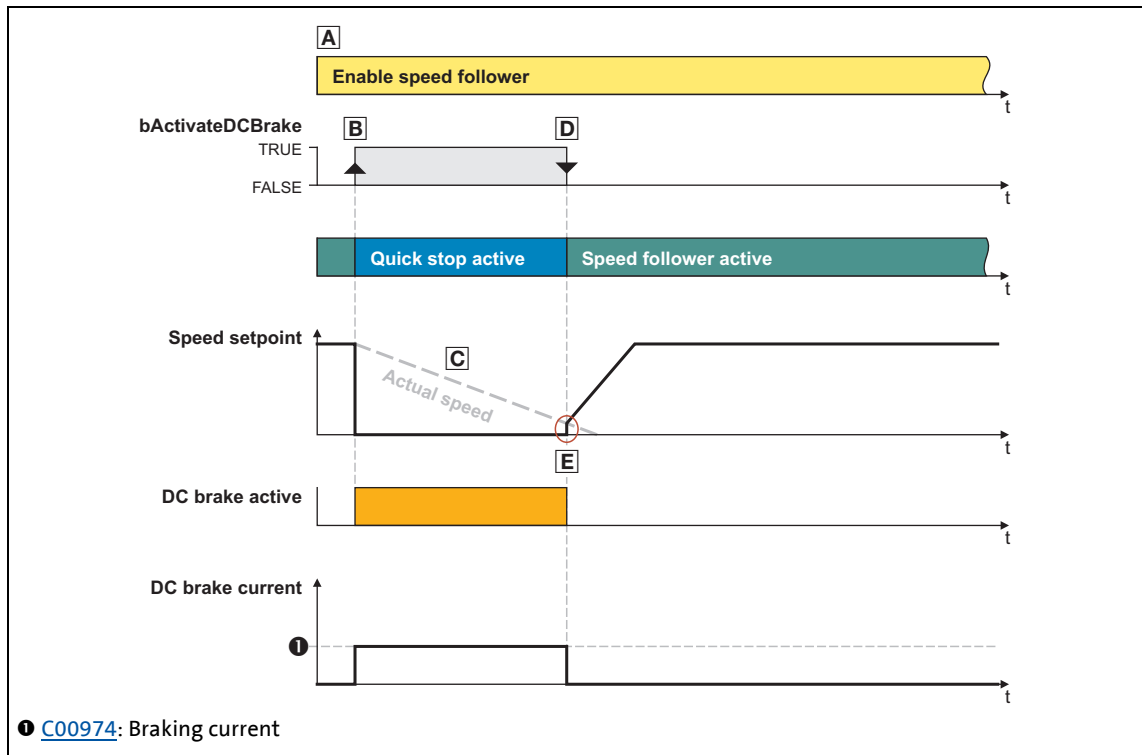

[11-14] Process example: speed follower is active → QSP\_bActivateDCBrake is active → speed follower is active

- A. Initial situation: basic function "Speed follower" is enabled and active.
- B. *QSP\_bActivateDCBrake* control input is set to TRUE through the application to activate DC-injection braking.
- C. DC-injection braking is executed with the braking current set in [C00974](#).
- D. *QSP\_bActivateDCBrake* control input is reset to FALSE through the application to deactivate DC-injection braking.
- E. The flying restart process starts, i.e. the controller calculates the output frequency required for the momentary motor speed, then connects to the system, and accelerates the motor to the defined setpoint again.

### 11.3.4.2 DC-injection braking when quick stop is activated

If DC-injection braking is activated in [C00976](#) instead of quick stop, DC-injection braking is executed automatically when quick stop is activated.

- After activating quick stop, a change-over to the "Quick stop active" function state is effected, and for the quick stop deceleration time set in [C00105](#) a DC-injection braking process with the braking current set in [C00975](#) is carried out.
- After this time has elapsed, a change-over to the braking current parameterised in [C00974](#) is carried out and DC-injection braking is continued with this braking current.
- The DC-injection braking in this case is also carried out when the "Quick stop by trouble" error response is actuated; however, instead of the "Quick stop active" function state, the "Fault" function state is active, and the controller is in the "Quick stop by trouble active" device state.

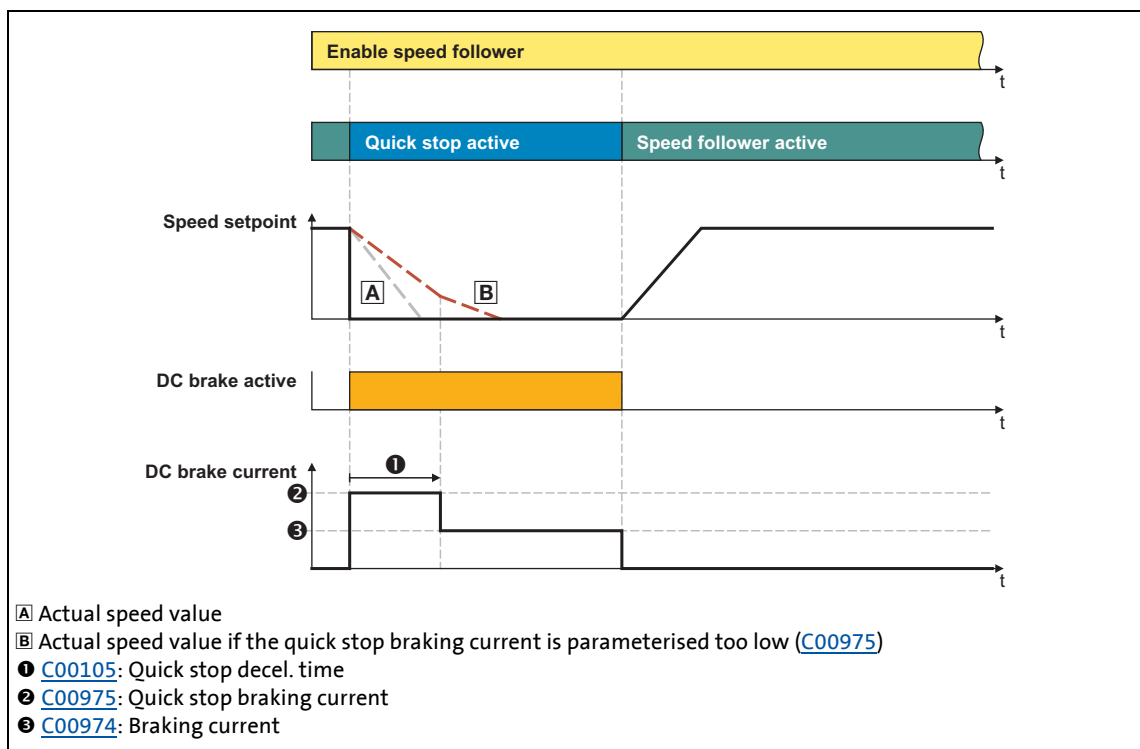

[11-15] Process example: speed follower is active → quick stop activation → speed follower is active



### Note!

The quick stop braking current in [C00975](#) has to be set so that the drive can be decelerated from the maximum operating speed to standstill within the deceleration time for quick stop set in [C00105](#)!

### 11.4 Manual jog

The basic function "Manual jog" serves to traverse the drive manually, e.g. to clean or exchange the tool.

- As an option, it is possible to change over to a second speed during traversing.
- "Retraction" of operated (travel range) limit switches is also supported. Only traversing in the corresponding retracting direction is then possible.



#### Danger!

During manual jogging, specially assigned profile parameters are active. If they have not been set correctly, the drive can engage in uncontrolled movement!



#### Stop!

In manual mode a travel range monitoring via limit switches and software limit positions is carried out via the basic function "[Limiter](#)". ([□ 506](#))

If no limit switches are connected and no software limit positions are set, and the reference is not known, the drive can travel into a mechanical barrier during manual mode and machine parts can be destroyed or damaged!



#### Note!

For manual jog setpoint speeds greater than 30000 rpm are not possible. The speeds defined for these basic function are internally limited to 30000 rpm.

When the basic function is activated, a start acceleration is considered. ▶ [Start acceleration/acceleration reduction when the basic function changes](#) ([□ 385](#))

**For the encoderless motor control types (from software version V3.0) the following applies:**

If no position controller has been selected for position control in case of V/f control or sensorless vector control ([C02570](#) = "1: Phase controller is active"), the manual jog is only executed via the speed profile resulting from the manual jog parameters.



### 11.4.1 Internal interfaces | "LS\_ManualJog" system block

The **LS\_ManualJog** system block provides the internal interfaces for the basic function "Manual jog" in the function block editor.

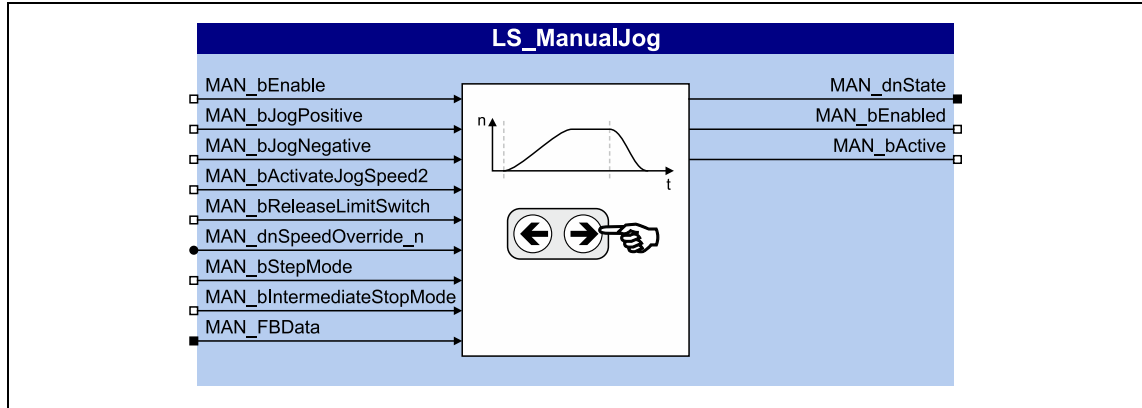

#### Note!

Ensure that the system block is called in a cyclic application task.

Basically, projects which only contain an unsolicited task and no cyclic task are not permissible!

#### Inputs

Identifier <small>DIS code   data type</small>	Information/possible settings			
MAN_bEnable <a href="#">C02639/1</a>   BOOL	Request control of basic function			
	<table border="1"> <tr> <td>TRUE</td> <td>If no other basic function is active, a change-over to the "Manual jog active" function state is effected and manual jog can be carried out via the control inputs.</td> </tr> <tr> <td>TRUE↔FALSE</td> <td>Active manual jog is stopped, i. e. a change-over from the active "Manual jog active" function state via the "Drive is stopped" function state back to the basic state "Drive at standstill" is carried out.</td> </tr> </table>	TRUE	If no other basic function is active, a change-over to the "Manual jog active" function state is effected and manual jog can be carried out via the control inputs.	TRUE↔FALSE
TRUE	If no other basic function is active, a change-over to the "Manual jog active" function state is effected and manual jog can be carried out via the control inputs.			
TRUE↔FALSE	Active manual jog is stopped, i. e. a change-over from the active "Manual jog active" function state via the "Drive is stopped" function state back to the basic state "Drive at standstill" is carried out.			
MAN_bJogPositive <a href="#">C02639/2</a>   BOOL	▶ <a href="#">Manual jog in positive/negative direction</a> (☞ 407)			
MAN_bJogNegative <a href="#">C02639/3</a>   BOOL				
MAN_bActivateJogSpeed2 <a href="#">C02639/4</a>   BOOL	Change over to speed 2 for manual jog			
	<table border="1"> <tr> <td>FALSE</td> <td>Speed 1 (<a href="#">C02620</a>) active.</td> </tr> <tr> <td>TRUE</td> <td>Speed 2 (<a href="#">C02621</a>) active.</td> </tr> </table>	FALSE	Speed 1 ( <a href="#">C02620</a> ) active.	TRUE
FALSE	Speed 1 ( <a href="#">C02620</a> ) active.			
TRUE	Speed 2 ( <a href="#">C02621</a> ) active.			
MAN_bReleaseLimitSwitch <a href="#">C02639/5</a>   BOOL	Retracting of an activated limit switch			
	<table border="1"> <tr> <td>TRUE</td> <td>Retracting of the accordingly operated limit switch in the corresponding retracting direction until the limit switch is cleared again (no longer operated) and the drive is within the software limit positions again. Afterwards the drive is braked to standstill with the deceleration set unless the control input <i>MAN_bJogPositive</i> or <i>MAN_bJogNegative</i> is activated for the corresponding retracting direction.</td> </tr> </table>	TRUE	Retracting of the accordingly operated limit switch in the corresponding retracting direction until the limit switch is cleared again (no longer operated) and the drive is within the software limit positions again. Afterwards the drive is braked to standstill with the deceleration set unless the control input <i>MAN_bJogPositive</i> or <i>MAN_bJogNegative</i> is activated for the corresponding retracting direction.	
TRUE	Retracting of the accordingly operated limit switch in the corresponding retracting direction until the limit switch is cleared again (no longer operated) and the drive is within the software limit positions again. Afterwards the drive is braked to standstill with the deceleration set unless the control input <i>MAN_bJogPositive</i> or <i>MAN_bJogNegative</i> is activated for the corresponding retracting direction.			

Identifier DIS code   data type	Information/possible settings		
MAN_dnSpeedOverride_n <small>C02637   DINT</small> <small>From V5.0</small>	Value for speed override <ul style="list-style-type: none"> <li>• Percentage multiplier for the currently active speed (<a href="#">C02620</a> or <a href="#">C02621</a>).</li> <li>• In the case of active manual jog, the speed override is always active and does not have to be activated separately.</li> <li>• Changes are accepted in each cycle.</li> <li>• <math>2^{30} \equiv 100\%</math> of the speed parameterised in <a href="#">C02620</a> or <a href="#">C02621</a>.</li> <li>• For values <math>\leq 1\%</math> the status bit 19 is set.</li> <li>• Values <math>\leq 0\%</math> are set to 0% internally and lead to the standstill of the drive.</li> </ul>		
MAN_bStepMode <small>C02639/8   BOOL</small> <small>From V5.0</small>	▶ <a href="#">Manual jog with step limitation</a> (☐ 408) <ul style="list-style-type: none"> <li>• Only possible if the "Manual jog with intermediate stop" mode is not active.</li> </ul> <table border="1" data-bbox="608 629 1441 667"> <tr> <td>TRUE</td> <td>Manual jog with step limitation active.</td> </tr> </table>	TRUE	Manual jog with step limitation active.
TRUE	Manual jog with step limitation active.		
MAN_bIntermediateStopMode <small>C02639/9   BOOL</small> <small>From V5.0</small>	▶ <a href="#">Manual jog with intermediate stop</a> (☐ 409) <ul style="list-style-type: none"> <li>• This mode has a higher priority than the "Manual jog with step limitation" mode.</li> </ul> <table border="1" data-bbox="608 734 1441 772"> <tr> <td>TRUE</td> <td>Manual jog with intermediate stop active.</td> </tr> </table>	TRUE	Manual jog with intermediate stop active.
TRUE	Manual jog with intermediate stop active.		
MAN_FBData <small>From V5.0</small>	Interface for the transfer of the function block instance data for determining the positions for intermediate stop <ul style="list-style-type: none"> <li>• Connect this input to the output <i>FBData</i> of the function block instance of type <b>L_PosPositionerTable</b> or <b>L_PosProfileTable</b>.</li> </ul>		

## Outputs

Identifier DIS code   data type	Value/meaning																																				
MAN_dnState <a href="#">C02638</a>   DINT	Status (bit coded) <ul style="list-style-type: none"> <li>• When the basic function is not enabled, all bits are set to "0".</li> <li>• Bits which are not listed are not assigned with a status (always "0").</li> </ul> <table border="1" data-bbox="608 483 1442 1491"> <tr><td>Bit 1</td><td>Manual jog active.</td></tr> <tr><td>Bit 2</td><td>Manual jog is completed.</td></tr> <tr><td>Bit 3</td><td>Acceleration/deceleration phase is active.</td></tr> <tr><td>Bit 5</td><td>CCW rotation is active.</td></tr> <tr><td>Bit 15</td><td>Fault in basic function active (group signal).</td></tr> <tr><td>Bit 16</td><td>Stop by simultaneous selection of negative direction and retraction of limit switch.</td></tr> <tr><td>Bit 17</td><td>Stop by simultaneous selection of positive and negative direction.</td></tr> <tr><td>Bit 18</td><td>Stop by simultaneous selection of positive direction and retraction of limit switch.</td></tr> <tr><td>Bit 19</td><td>Speed override ≤1 % • This status is only available from software version V5.0.</td></tr> <tr><td>Bit 20</td><td>Speed 2 (<a href="#">C02621</a>) active.</td></tr> <tr><td>Bit 21</td><td>Speed 1 (<a href="#">C02620</a>) active.</td></tr> <tr><td>Bit 22</td><td>Stop by selection of positive direction and simultaneous activation of the positive software limit position or the positive limit switch.</td></tr> <tr><td>Bit 23</td><td>Stop by selection of negative direction and simultaneous activation of the negative software limit position or the negative limit switch.</td></tr> <tr><td>Bit 24</td><td>General abort process (ramp down of the speed setpoint) • Takes place e.g. when a manual direction initiator is released or due to an impermissible state (see bit 16, 17, 18, 22, 23).</td></tr> <tr><td>Bit 25</td><td>Stopping is active. • Basic function enabled for the first time but no manual jog has been requested/is active yet or current speed is higher than the manual jog speed.</td></tr> <tr><td>Bit 26</td><td>Home position is not known. • This status is only available from software version V5.0.</td></tr> <tr><td>Bit 27</td><td>No intermediate stop position available. • This status is only available from software version V5.0.</td></tr> <tr><td>Bit 30</td><td>Profile generation error.</td></tr> </table>	Bit 1	Manual jog active.	Bit 2	Manual jog is completed.	Bit 3	Acceleration/deceleration phase is active.	Bit 5	CCW rotation is active.	Bit 15	Fault in basic function active (group signal).	Bit 16	Stop by simultaneous selection of negative direction and retraction of limit switch.	Bit 17	Stop by simultaneous selection of positive and negative direction.	Bit 18	Stop by simultaneous selection of positive direction and retraction of limit switch.	Bit 19	Speed override ≤1 % • This status is only available from software version V5.0.	Bit 20	Speed 2 ( <a href="#">C02621</a> ) active.	Bit 21	Speed 1 ( <a href="#">C02620</a> ) active.	Bit 22	Stop by selection of positive direction and simultaneous activation of the positive software limit position or the positive limit switch.	Bit 23	Stop by selection of negative direction and simultaneous activation of the negative software limit position or the negative limit switch.	Bit 24	General abort process (ramp down of the speed setpoint) • Takes place e.g. when a manual direction initiator is released or due to an impermissible state (see bit 16, 17, 18, 22, 23).	Bit 25	Stopping is active. • Basic function enabled for the first time but no manual jog has been requested/is active yet or current speed is higher than the manual jog speed.	Bit 26	Home position is not known. • This status is only available from software version V5.0.	Bit 27	No intermediate stop position available. • This status is only available from software version V5.0.	Bit 30	Profile generation error.
Bit 1	Manual jog active.																																				
Bit 2	Manual jog is completed.																																				
Bit 3	Acceleration/deceleration phase is active.																																				
Bit 5	CCW rotation is active.																																				
Bit 15	Fault in basic function active (group signal).																																				
Bit 16	Stop by simultaneous selection of negative direction and retraction of limit switch.																																				
Bit 17	Stop by simultaneous selection of positive and negative direction.																																				
Bit 18	Stop by simultaneous selection of positive direction and retraction of limit switch.																																				
Bit 19	Speed override ≤1 % • This status is only available from software version V5.0.																																				
Bit 20	Speed 2 ( <a href="#">C02621</a> ) active.																																				
Bit 21	Speed 1 ( <a href="#">C02620</a> ) active.																																				
Bit 22	Stop by selection of positive direction and simultaneous activation of the positive software limit position or the positive limit switch.																																				
Bit 23	Stop by selection of negative direction and simultaneous activation of the negative software limit position or the negative limit switch.																																				
Bit 24	General abort process (ramp down of the speed setpoint) • Takes place e.g. when a manual direction initiator is released or due to an impermissible state (see bit 16, 17, 18, 22, 23).																																				
Bit 25	Stopping is active. • Basic function enabled for the first time but no manual jog has been requested/is active yet or current speed is higher than the manual jog speed.																																				
Bit 26	Home position is not known. • This status is only available from software version V5.0.																																				
Bit 27	No intermediate stop position available. • This status is only available from software version V5.0.																																				
Bit 30	Profile generation error.																																				
MAN_bEnabled <a href="#">C02639/6</a>   BOOL	Status signal "Basic function is enabled" <table border="1" data-bbox="608 1532 1442 1621"> <tr> <td>TRUE</td> <td>Manual jog via the control inputs is possible. • The <i>MAN_bEnable</i> enable input is set to TRUE and the controller is in the "Manual jog active" function state.</td> </tr> </table>	TRUE	Manual jog via the control inputs is possible. • The <i>MAN_bEnable</i> enable input is set to TRUE and the controller is in the "Manual jog active" function state.																																		
TRUE	Manual jog via the control inputs is possible. • The <i>MAN_bEnable</i> enable input is set to TRUE and the controller is in the "Manual jog active" function state.																																				
MAN_bActive <a href="#">C02639/7</a>   BOOL	Status signal "Basic function is active" <table border="1" data-bbox="608 1662 1442 1697"> <tr> <td>TRUE</td> <td>Manual jog is active (the drive axis is moving).</td> </tr> </table>	TRUE	Manual jog is active (the drive axis is moving).																																		
TRUE	Manual jog is active (the drive axis is moving).																																				

### 11.4.2 Parameter setting

- Parameterisation dialog in »Engineer«: Tab **Application parameters** → Dialog level *Overview* → *All basic functions* → *Manual jog*
- Short overview of the parameters for manual jog:

Parameters	Info
<a href="#">C02620</a>	Manual jog: Speed 1
<a href="#">C02621</a>	Manual jog: Speed 2
<a href="#">C02622</a>	Manual jog: Acceleration
<a href="#">C02623</a>	Manual jog: Deceleration
<a href="#">C02624</a>	Manual jog: S-ramp time
<a href="#">C02625</a>	Manual jog: Step distance
<a href="#">C02626/1...16</a>	Manual jog: Index stop position
<a href="#">C02627/1...16</a>	Manual jog: Selected stop position

Greyed out = display parameter

#### 11.4.2.1 Smooth start and quick stop of the drive

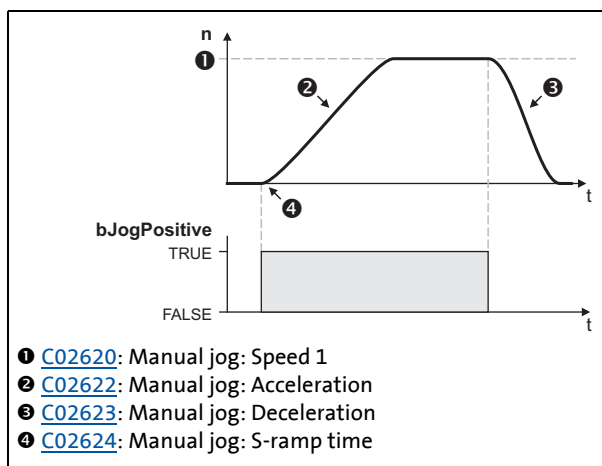

[11-16] Example: Smooth start and quick stop



#### Tip!

A quick deceleration ([C02623](#)) reduces the time from letting go of the "Jog key" to the actual stop of the drive, so that the drive can thus be better positioned "by eye" and the desired stop position is not overtravelled.

- Different values for acceleration and deceleration can be set in [C02622/](#) [C02623](#) in order to implement a smooth start and a quick stop of the drive.
- By entering a relative S-ramp time in [C02624](#) both ramps can be set in S-shape for jerk reduction. ▶ [Setting the S-ramp time](#) (□ 387)

### 11.4.2.2 Second speed

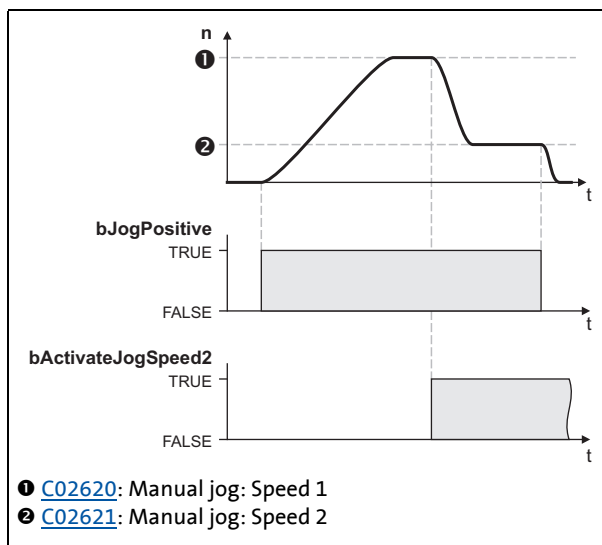

- By setting the input *MAN\_bActivateJogSpeed2* to TRUE, a change-over to a second speed ([C02621](#)) can be carried out during the traversing process.

[11-17] Example: Change-over to second speed

### 11.4.3 Executing manual jogging

#### Prerequisites

- The controller is in the "Operation" device state.
- The basic function "manual jog" is part of the active application.
- No other basic function is active.

#### Activation

To request the control via the basic function, the *MAN\_bEnable* enable input in the application must be set to TRUE.

- If no other basic function is active, a change-over to the "Manual jog active" function state is effected and manual jog can be carried out via the control inputs.
- A successful change to the function state "Manual jog active" is displayed by a TRUE signal at the *MAN\_bEnabled* status output.

#### Deactivation

If the *MAN\_bEnable* enable input is reset to FALSE, an active manual jog is reset, i.e. the control inputs for manual jog are inhibited and the drive is braked to standstill within the deceleration time for [Stop](#). ([📖 389](#))

- The status output *MAN\_bEnabled* is reset to FALSE and a change-over from the active "Manual jog active" function state via the "Drive is stopped" function state back to the basic state "Drive at standstill" is carried out.

### 11.4.3.1 Manual jog in positive/negative direction

In the "Manual jog active" function state the drive can be traversed manually according to the following truth table via the control inputs:

MAN_bJogNegative	MAN_bJogPositive	MAN_bActivateJogSpeed2	Job title
FALSE	FALSE	-	Stop <ul style="list-style-type: none"> <li>The drive is controlled to standstill at the set rate of deceleration.</li> </ul>
FALSE	TRUE	FALSE	Manual jog <ul style="list-style-type: none"> <li>In positive direction</li> <li>Using speed 1 (<a href="#">C02620</a>)</li> </ul>
		TRUE	Manual jog <ul style="list-style-type: none"> <li>In positive direction</li> <li>Using speed 2 (<a href="#">C02621</a>)</li> </ul>
TRUE	FALSE	FALSE	Manual jog <ul style="list-style-type: none"> <li>In negative direction</li> <li>Using speed 1 (<a href="#">C02620</a>)</li> </ul>
		TRUE	Manual jog <ul style="list-style-type: none"> <li>In negative direction</li> <li>Using speed 2 (<a href="#">C02621</a>)</li> </ul>
TRUE	TRUE	-	When both inputs are set to TRUE at the same time: <ul style="list-style-type: none"> <li>The drive is controlled to standstill at the set rate of deceleration.</li> </ul> If not both inputs are set to TRUE at the same time: <ul style="list-style-type: none"> <li>The drive continues to traverse in the direction that was selected first.</li> </ul>



#### Note!

In the standard technology applications "Actuating drive – speed" and "Actuating drive – torque", in the Lenze setting the control inputs are linked to the following digital inputs:

- **DI6:** Activate manual mode
- **DI7:** Manual jog in positive direction
- **DI8:** Manual jog in negative direction

### 11.4.3.2 Manual jog with step limitation

This function extension is available from software version V5.0 onwards!

---

This mode can be activated via the control input *MAN\_bStepMode*.

In the "Manual jog with step limitation" mode the drive traverses by the "step distance" parameterised in [C02625](#) if a direction is requested via the control inputs *MAN\_bJogPositive*/*MAN\_bJogNegative*. After traversing this distance, the drive stops.

- A new positive edge for the routing request causes a restart of the function or a reset of the distance counter, even if the drive is not at standstill yet.
- If the routing request is reset before the distance is reached, the drive stops immediately (with the deceleration set).



#### Note!

The two modes "Manual jog with step limitation" and "Manual jog with intermediate stop" cannot be active at the same time.

If there is a simultaneous request via the control inputs *MAN\_bStepMode* and *MAN\_bIntermediateStopMode*, only the "Manual jog with intermediate stop" mode is active. ▶ [Manual jog with intermediate stop](#) (📖 409)



### 11.4.3.3 Manual jog with intermediate stop

This function extension is available from software version V5.0 onwards!

This mode can be activated via the control input *MAN\_bIntermediateStopMode*.

In the "Manual jog with intermediate stop" mode, in the case of a routing request via the control inputs *MAN\_bJogPositive*/*MAN\_bJogNegative* the drive traverses to the defined "Intermediate stop position" that is next in the corresponding direction.

MAN_bJogNegative	MAN_bJogPositive	Job title
FALSE	TRUE	Drive traverses from the current position to the next target in positive direction of the intermediate positions defined.
TRUE	FALSE	Drive traverses from the current position to the next target in negative direction of the intermediate positions defined.

- The drive stops on the intermediate position that is approached.
- If the routing request is reset before the intermediate position is reached, the drive stops immediately (with the deceleration set).
- After the drive has stopped on the intermediate position, it can only continue after a new positive edge for the routing request.
- If the drive is in the outmost intermediate position defined and a new routing request is effected, the drive stops.



#### Note!

Requirements for manual jog with intermediate stop:

- The home position is known (otherwise status bit 26 is set).
- At least one intermediate stop position is defined (otherwise status bit 27 is set).

#### Selection of the intermediate stop positions

The max. 16 intermediate stop positions are selected/defined via a function block instance of type **L\_PosPositionerTable** or **L\_PosProfileTable**.

- For the transfer of the intermediate stop positions the output *FBData* of the respective function block instance is to be connected to the input *MAN\_FBData* of the **LS\_ManualJog** SB.
- The positions defined by the function block instance, which are to be used as intermediate stop positions are selected via [C02626/1...16](#).
  - In connection with a function block instance of type **L\_PosPositionerTable**:  
In [C02626/x](#) the index [1...75] of the table position in the VTPOS table has to be specified, which contains the intermediate stop position x that is to be used.
  - In connection with a function block instance of type **L\_PosProfileTable**:  
In [C02626/x](#) the index [1...4] of the profile data set has to be specified, which contains the intermediate stop position x that is to be used.
- The positions selected are shown in [C02627/1...16](#).

### 11.4.3.4 Manual jog to limit position



#### Note!

Detailed information on travel range monitoring via limit switches and software limit positions can be found in the description of the basic function "[Limiter](#)". ([506](#))

#### Manual jog to software limit position

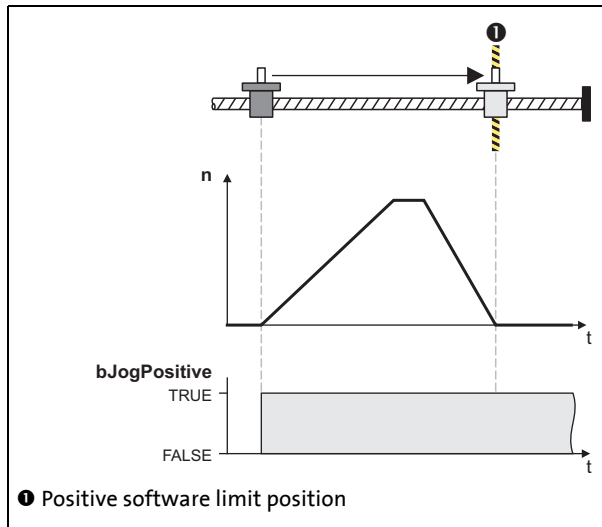

[11-18] Example: Manual jog to positive software limit position

- If the reference is known and the software limit positions are set, a positioning to the corresponding software limit position is carried out, if manual jog was not exited manually before by resetting *MAN\_bJogNegative* or *MAN\_bJogPositive*.
- The drive brakes with the deceleration set ([C02623](#)) to the position of the corresponding software limit position.

#### Manual jog to hardware limit position (limit switch)

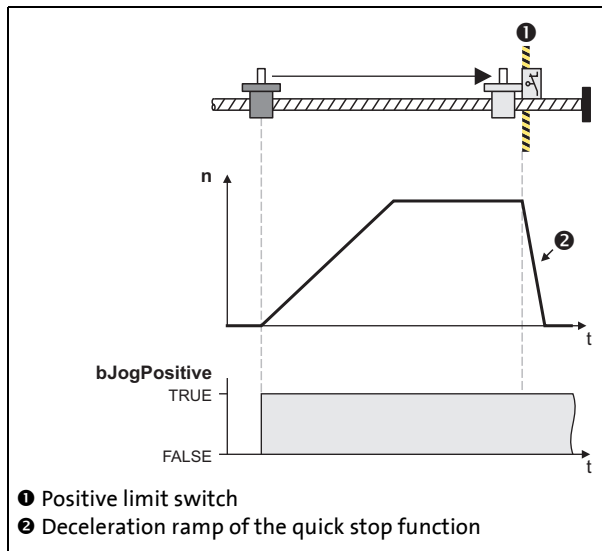

[11-19] Example: Manual jog to positive limit switch

- When a limit switch is approached during manual jog, the drive is braked to standstill within the deceleration time set for the quick stop function.

See also: [▶ Software limit positions](#) ([512](#))  
[▶ Hardware limit positions \(limit switch\)](#) ([515](#))

### 11.4.3.5 Retracting of an activated limit switch

By setting *MAN\_bReleaseLimitSwitch* to TRUE, retracting from an operated limit switch is possible. The traversing process in the corresponding retracting direction is carried out until the limit switch is no longer activated.

- If, while retracting, a direction is selected additionally via the control inputs *MAN\_bJogPositive* or *MAN\_bJogNegative* towards the retracting direction, the travel is continued even after the limit switch has been abandoned until *MAN\_bJogPositive* or *MAN\_bJogNegative* are reset to FALSE.
- If the direction opposite to the retracting direction is preselected instead, the drive stops, and a corresponding status is shown via the status output *MAN\_dnState*.



#### Note!

Retracting from a limit switch is only possible if it is still activated, i. e. if the corresponding limit switch input of the limiter is still activated. Therefore ensure that if a limit switch is approached, its trigger mechanics is not "overtravelled", for instance by a too great mass or drive, so that by this the limit switch is no longer activated.



#### Tip!

An activated limit switch can also be exited again by manual jog in the retracting direction via the control input *MAN\_bJogPositive* or *MAN\_bJogNegative*.

*See also:* [▶ Hardware limit positions \(limit switch\) \(📖 515\)](#)

# 11 Basic drive functions

## 11.5 Manual job, encoderless

### 11.5 Manual job, encoderless

This function extension is available from software version V7.0!



#### Danger!

In this basic function, the extent of the useable operating modes of the holding brake is restricted. Only the following operating modes function:

- Directly with brake module ([C02580, selection 1](#)) and
- Direct switching externally ([C02580, selection 11](#))

The basic function "Manual jog (OL)", which is implemented in the motor control system of the drive controller, enables the user to operate the drive without control (i.e. "open loop", encoderless) and independently of the selected operating mode:

- If the motor is asynchronous, the speed depends on the load.
- A synchronous motor turns with a prescribed field frequency.



#### Stop!

It is only permissible to activate controlled operation of synchronous machines if the following parameters have been set correctly, in addition to correct assignment of the encoder image and the motor's rotating field:

- Motor control SC, "Servo control of sync motor" ([C00006, selection 1](#))
- Pole position of the motor encoder ([C00058](#))
- Motor data ([C00081 ... C00091](#))
- Active resolver feedback or encoder feedback as motor encoder ([C00420 ... C00422](#))

#### The basic function "Manual jog (OL)"

- is based on the I-rotation test mode and is especially suitable for the operation of synchronous motors. There is a corresponding dialog box in »Engineer«
- is not identical with sensorless operation of synchronous machines. In the basic function "Manual jog (OL)", neither parameters relevant to the motor model nor parameters relevant to the motor type are used
- can be activated and controlled by means of process data (system block inputs) or by accessing codes (e.g. via keypad).

#### Uses of "Manual job, encoderless"

- Test of hardware (e.g. connection system, rotating field and motor cables) during initial commissioning and during servicing
- Movement of the drive or machine to a service position in the event of defective encoder feedback
- Functional test of the discretely structured feedback system of a torque or linear motor.

# 11 Basic drive functions

## 11.5 Manual job, encoderless

- Support for [Pole position identification](#) (☰ 131) in the case of torque and linear motors by means of
  - movement to a machine position in which pole position identification can be carried out in a reproducible manner and
  - setting of the pole position angle with the "PL touch probe signal"

### 11.5.1 Parameter setting

- Parameterising dialog box in »Engineer«: Tab **Application parameters** → Dialog level *Overview* → *All basic functions* → *Manual jog (OL)*
- Short overview of the parameters for manual jog, encoderless:

Parameters	Info	Lenze setting	
		Value	Unit
<a href="#">C02770/1</a>	EnableManualMode	0: Deactivate	
<a href="#">C02770/2</a>	JogPositive	0: Deactivate	
<a href="#">C02770/3</a>	JogNegative	0: Deactivate	
<a href="#">C02770/4</a>	ActivateDataBit1	0: Deactivate	
<a href="#">C02770/5</a>	ActivateDataBit2	0: Deactivate	
<a href="#">C02771/1...4</a>	Frequency <ul style="list-style-type: none"><li>• Field frequency <math>f_d</math> with which the current vector rotates.</li></ul>	1.0	Hz
<a href="#">C02772/1...4</a>	Start angle	0.0	°
<a href="#">C02773/1...4</a>	Current <ul style="list-style-type: none"><li>• R.m.s. value of the current vector which is injected with the parameterised frequency/starting angle.</li><li>• 100 % <math>\equiv I_{\max\_device}</math> (<a href="#">C00022</a>)</li></ul>	10.00	%
<a href="#">C02774/1...4</a>	Acceleration time	1.000	s
<a href="#">C02775/1...4</a>	Deceleration time	1.000	s
<a href="#">C02776/1...4</a>	Max. activation time	1.000	s
<a href="#">C02779</a>	Mol_SetpointCurrent	-	A
<a href="#">C02780</a>	Mol_dnState	-	
<a href="#">C02781</a>	ManualJogOpenLoop: Dig. signals	-	

Greyed out = display parameter



### Stop!

At the frequency  $f_d = 0$  Hz, the r.m.s. value increases to 141 % of the current parameterised in [C02773/x](#). As a result, the connected motor can be destroyed!

**Remedy:** Activation of a derating curve in i2xt monitoring or limitation of the parameterised current in [C02773/x](#) to 71 % of the rated motor current. ▶ [Motor monitoring \(I<sup>2</sup>xt\)](#) (☰ 218)

### 11.5.2 Carrying out encoderless manual jogging

The procedure for using this basic function is described with reference to the signal characteristic shown below.

Please refer to the following chapters for more information

- ▶ [Prerequisites](#)
- ▶ [Activation / Deactivation](#)
- ▶ [Selection and contents of the profile parameter set](#)
- ▶ [Encoderless manual jogging in a positive/negative direction](#)

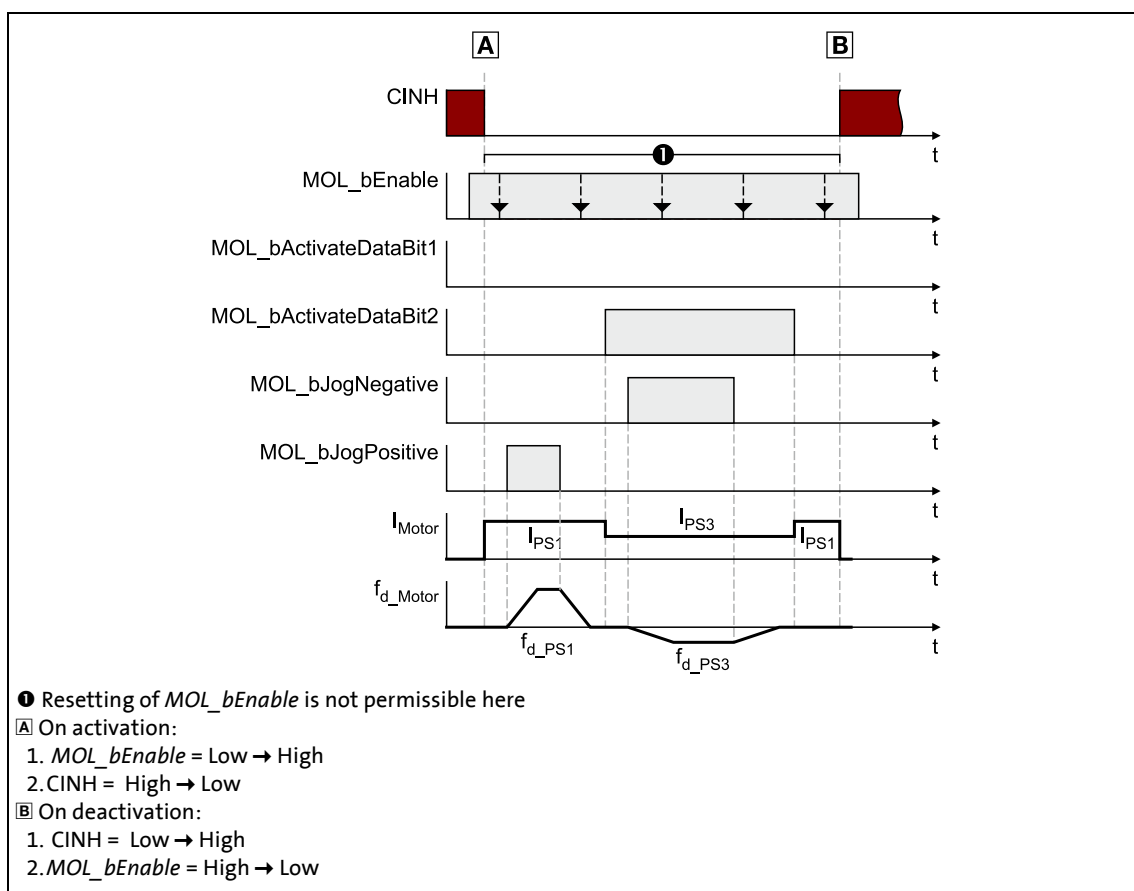

[11-20] Signal characteristic: activation/deactivation of basic function "manual jog (OL)"

### 11.5.2.1 Prerequisites

- Check and, if necessary, adjust the basic parameterisation:
  - Optimisation of the current controller in the case of non-Lenze motors or motors that are not included in the »Engineer« motor catalogue. ▶ [Optimise current controller](#) (☞ 181)
  - Parameterisation of motor monitoring corresponding to the existing motor with the monitoring response "Fault". ▶ [Motor monitoring \(I<sup>2</sup>xt\)](#) (☞ 218)
  - This function is especially important for monitoring the permissible r.m.s. current load on motors at  $f_d = 0$  Hz.
  - Activation of maximum current monitoring with the monitoring response "Fault" in the case of non-Lenze motors or motor that are not included in the »Engineer« motor catalogue. ▶ [Maximum current monitoring](#) (☞ 233)
  - Activation of motor temperature monitoring via PTC and/or KTY. ▶ [Motor temperature monitoring](#) (☞ 225)
- The controller inhibit is active.
- The controller is in the "Controller not ready" state ▶ [Device states](#) (☞ 100).
- The basic function "Manual jog (OL)" is part of the active application; see ▶ [Internal interfaces | "LS\\_ManualJogOpenLoop" system block](#) (☞ 419).
- No other basic function is active.

### 11.5.2.2 Activation

In order to request the control via the basic function, the *MOL\_bEnable* enable input in the application must be set to TRUE or [C02770/1](#) to "1".

- If no other basic function is active, a changeover to the function state "Manual jog, encoderless active" takes place and controlled traversing can be carried out by means of the control inputs or by writing values into [C02770/2...5](#).
- A successful changeover to the function state "Manual jog, encoderless active" is indicated by a TRUE signal at the status output *MOL\_bEnabled*.

# 11 Basic drive functions

## 11.5 Manual job, encoderless

### 11.5.2.3 Deactivation



#### Stop!

Before the basic function is deactivated, the controller inhibit must be set. Otherwise, unsteady drive behaviour can occur when a changeover is made from the basic function "Manual jog, encoderless" to the basic function "Stop".

The basic function is deactivated by

- setting the input "MOL\_bEnable" to FALSE or
- removing the checkmark (if there is one) in the »Engineer« dialog box entitled *Manual control (parameter set 1)*.

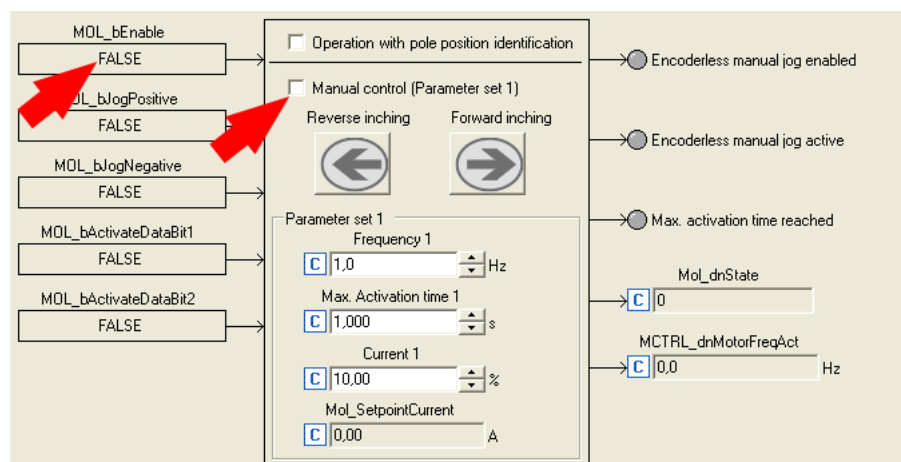

[11-21] Deactivation of the basic function "Manual jog, encoderless"



### 11.5.2.4 Selection and contents of the profile parameter set

For controlled traversing, four different profiles can be parameterised. The profile parameter set to be used is selected by means of the control inputs *MOL\_bActivateDataBit1* [C02781/4](#) and *MOL\_bActivateDataBit2* [C02781/5](#) or alternatively by means of the parameters [C02770/4](#) (*ActivateDataBit1*) and [C02770/5](#) (*ActivateDataBit2*):

<i>MOL_bActivateDataBit2</i> <a href="#">C02781/5</a>	<i>MOL_bActivateDataBit1</i> <a href="#">C02781/4</a>	Selected profile parameter set
FALSE	FALSE	Profile parameter set 1
FALSE	TRUE	Profile parameter set 2
TRUE	FALSE	Profile parameter set 3
TRUE	TRUE	Profile parameter set 4

Setpoint	Profile parameter set 1	Profile parameter set 2	Profile parameter set 3	Profile parameter set 4
Frequency	<a href="#">C02771/1</a>	<a href="#">C02771/2</a>	<a href="#">C02771/3</a>	<a href="#">C02771/4</a>
Start angle	<a href="#">C02772/1</a>	<a href="#">C02772/2</a>	<a href="#">C02772/3</a>	<a href="#">C02772/4</a>
Current	<a href="#">C02773/1</a>	<a href="#">C02773/2</a>	<a href="#">C02773/3</a>	<a href="#">C02773/4</a>
Acceleration time	<a href="#">C02774/1</a>	<a href="#">C02774/2</a>	<a href="#">C02774/3</a>	<a href="#">C02774/4</a>
Deceleration time	<a href="#">C02775/1</a>	<a href="#">C02775/2</a>	<a href="#">C02775/3</a>	<a href="#">C02775/4</a>
Max. activation time	<a href="#">C02776/1</a>	<a href="#">C02776/2</a>	<a href="#">C02776/3</a>	<a href="#">C02776/4</a>



#### Note!

The four profile parameter sets must be dealt with sequentially, i.e. a selected profile parameter set must first be completed with  $f_d = 0$  Hz before a further profile parameter set can be activated.

- The signal characteristic in Fig. [\[11-20\]](#) (□ 414) shows that the drive must ramp down completely in the case of each parameter set before the next parameter set can be started.
- Lenze recommends to control the basic function in accordance with this signal characteristic.

# 11 Basic drive functions

## 11.5 Manual job, encoderless

---

### 11.5.2.5 Encoderless manual jogging in a positive/negative direction

In the function state "Manual jog, encoderless active", the drive can be traversed manually in accordance with the following truth table by means of the indicated control inputs:

MOL_bJogNegative <a href="#">C02770/3</a>	MOL_bJogPositive <a href="#">C02770/2</a>	Job title
FALSE	FALSE	Stop • The drive is braked to standstill with the deceleration time in <a href="#">(C02775/x)</a> set for the selected profile.
FALSE	TRUE	Controlled traversing in positive direction • The drive is led to the setpoint frequency with the acceleration time <a href="#">(C02774/x)</a> set for the selected profile <a href="#">(C02771/x)</a> .
TRUE	FALSE	Controlled traversing in negative direction • The drive is led to the setpoint frequency with the acceleration time <a href="#">(C02774/x)</a> set for the selected profile <a href="#">(C02771/x)</a> .
TRUE	TRUE	When both inputs are set to TRUE at the same time: • The drive is braked to standstill with the deceleration time in <a href="#">(C02775/x)</a> set for the selected profile. If not both inputs are set to TRUE at the same time: • The drive continues to traverse in the direction that was selected first.
		x = number (1...4) of the selected profile parameter set

# 11 Basic drive functions

## 11.5 Manual job, encoderless

### 11.5.3 Internal interfaces | "LS\_ManualJogOpenLoop" system block

In the function block editor, the system block **LS\_ManualJogOpenLoop** makes the internal interfaces to the basic function "Manual jog, encoderless" available.

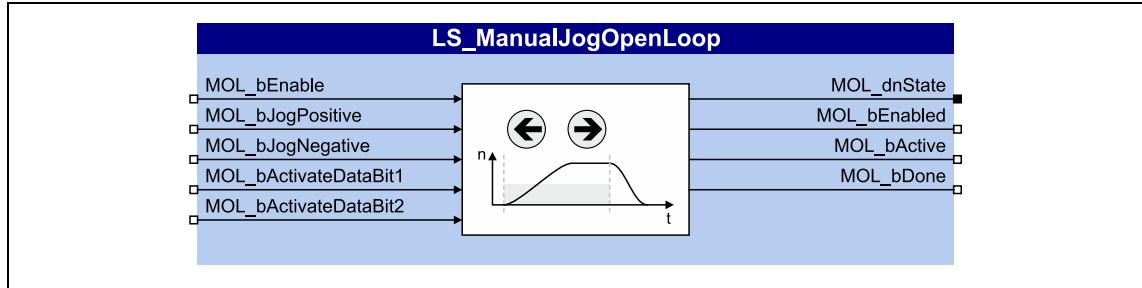

#### Note!

For the basic function "Manual jog, encoderless", the system block must be integrated into the application task. When the FB editor is activated, the basic dialog boxes of the corresponding technology application in »Engineer« change.

In the dialog box entitled "All basic functions", the "Manual jog, encoderless" button is not shown until the project has been updated.

#### Inputs

Identifier <small>DIS code   data type</small>	Information/possible settings
MOL_bEnable <a href="#">C02781/1</a>   BOOL	Request control of basic function <ul style="list-style-type: none"> <li>Request is also possible via <a href="#">C02770/1</a>.</li> </ul>
	TRUE If no other basic function is active, a changeover to the function state "Manual jog, encoderless active" takes place and controlled traversing of the drive can be carried out by means of the control inputs
	TRUE↘FALSE Actively controlled traversing is ended, i.e. a changeover from the active function state "Manual jog, encoderless active" back to the basic state "Controller not ready" takes place.
MOL_bJogPositive <a href="#">C02781/2</a>   BOOL	▶ <a href="#">Encoderless manual jogging in a positive/negative direction (418)</a> <ul style="list-style-type: none"> <li>Control is also possible via <a href="#">C02770/2</a> and <a href="#">C02770/3</a>.</li> </ul>
MOL_bJogNegative <a href="#">C02781/3</a>   BOOL	
MOL_bActivateDataBit1 <a href="#">C02781/4</a>   BOOL	▶ <a href="#">Selection and contents of the profile parameter set (417)</a> <ul style="list-style-type: none"> <li>Selection is also possible via <a href="#">C02770/4</a> and <a href="#">C02770/5</a>.</li> </ul>
MOL_bActivateDataBit2 <a href="#">C02781/5</a>   BOOL	

## Outputs

Identifier DIS code   data type	Value/meaning
Mol_dnState <a href="#">C02780</a>   DINT	Status (bit coded) <ul style="list-style-type: none"> <li>When the basic function is not enabled, all bits are set to "0".</li> <li>Bits which are not listed are not assigned with a status (always "0").</li> </ul>
	Bit 1   Manual jog, encoderless active.
	Bit 2   Profile executed.
	Bit 16   Request for "Quick stop" (QSP) active
MOL_bEnabled <a href="#">C02781/6</a>   BOOL	Status signal "Basic function is enabled"
	TRUE   Controlled traversing via the control inputs is possible. <ul style="list-style-type: none"> <li>The enable input <i>MOL_bEnable</i> has been set to TRUE and the controller is in the function state "Manual job, encoderless active".</li> </ul>
MOL_bActive <a href="#">C02781/7</a>   BOOL	Status signal "Basic function is active"
	TRUE   Controlled traversing is active (the drive axis moves according to the defined profile).
MOL_bDone <a href="#">C02781/8</a>   BOOL	Status signal "Max. activation time reached" <ul style="list-style-type: none"> <li>The status signal indicates that the respective parameterised max. activation time has been reached.</li> <li>The counter of the max. activation time is reset every time there is a TRUE-FALSE edge at <i>MOL_bJogPositive</i>/<i>MOL_bJogNegative</i>.</li> <li>The setpoint frequency and therefore the rotating field at the motor terminals is generated within the acceleration time parameterised in <a href="#">C02774/1...4</a> for the selected profile and the drive movement starts accordingly.</li> <li>At the instant of "Max. activation time reached", the drive is still moving and ramping down within the deceleration time parameterised in <a href="#">C02775/1...4</a> for the selected profile is initiated.</li> </ul>
	TRUE   Controlled manual jogging is active <ul style="list-style-type: none"> <li>The max. activation time parameterised for the selected profile in <a href="#">C02776/1...4</a> has expired.</li> <li><i>MOL_bJogPositive</i> or <i>MOL_bJogNegative</i> is TRUE</li> <li>The setpoint frequency still corresponds to the setpoint frequency parameterised in <a href="#">C02771/1...4</a> for the selected profile.</li> </ul>

### 11.6 Homing

With the basic function "Homing" the measuring system of the machine is transmitted to the controller within the travel range that is physically possible.

- The reference (e.g. zero position of the drive axis in the machine measuring system) can be defined by reference search or reference setting.
- In case of reference search, the drive travels according to the defined homing mode to detect the reference in the measuring system independently.
  - In the reference point, the home position parameterised in [C02642](#) is set as the current position. Afterwards, an absolute positioning to the target position parameterised in [C02643](#) takes place (if [C02641](#) = "0").
- If the reference is set in the homing mode "100: Set reference directly" or via the control input *HM\_bLoadHomePos*, the drive can also be referenced manually if the motor is at standstill. The measuring system is set by means of the home position parameterised in [C02642](#) or applied at the input *HM\_dnHomePos\_p*.



#### Danger!

During homing, specially assigned profile parameters are active. If they have not been set correctly, the drive can engage in uncontrolled movement!



#### Note!

Normally homing is only required once during commissioning of systems for which the machine cycle can be represented in the display area of the encoder, e. g. if multiturn absolute value encoders or singleturn absolute value encoders/resolvers are used during the machine cycle on one motor revolution.

- The encoder position is stored safe against mains failure in the memory module and is therefore known to the drive control even after the mains has been switched. ▶ [Behaviour of the home position after mains switching](#) (□ 426)
- A renewed reference setting is only required in case of a renewed commissioning or in case of service (e.g. when drive components are exchanged).
- When multipole resolvers ([C00080](#) > 1) are used, a renewed homing is required after mains switching due to the ambiguity of the evaluated position.

**Note!**

For homing, setpoint speeds greater than 30000 rpm are not possible. The speeds defined for these basic function are internally limited to 30000 rpm.

When the basic function is activated, a start acceleration is considered. ▶ [Start acceleration/acceleration reduction when the basic function changes](#) (□ 385)

**For the encoderless motor control types (from software version V3.0) the following applies:**

The basic function "Homing" can only be activated for V/f control or sensorless vector control if the position controller has been selected for the position control ([C02570](#) = "2: position controller active").

- The homing modes 14 & 15 are not permissible for the V/f control. If the selection is impermissible, the error message "Homing mode not allowed" is output.

**For the encoderless motor control types (from software version V5.0) the following applies:**

If the V/f control or sensorless vector control is selected, the basic function "Homing" can be activated, irrespective of the use of the position controller.

- If no position controller has been selected for the position control in case of V/f control or sensorless vector control ([C02570](#) = "1: Phase controller is active"), homing is only carried out via the speed profile resulting from the homing parameters. Because of this, the target positions set will only "roughly" be reached.

### 11.6.1 Internal interfaces | "LS\_Homing" system block

The **LS\_Homing** system block provides the internal interfaces for the basic function "Homing" in the function block editor.

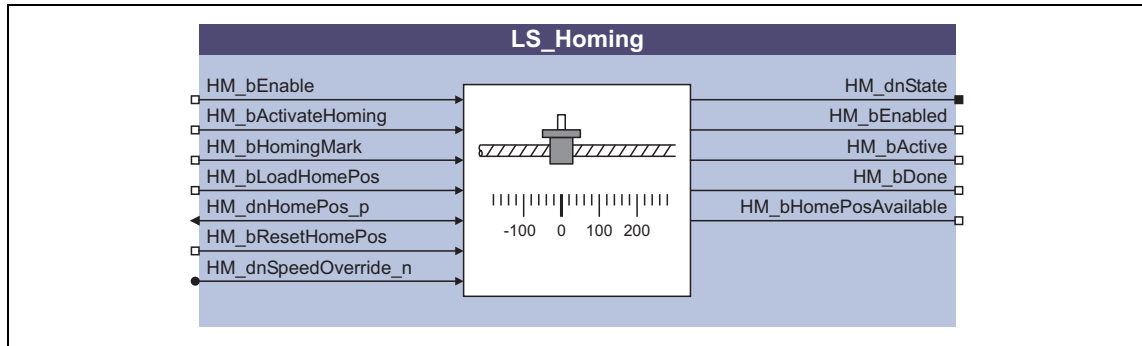

#### Note!

Ensure that the system block is called in a cyclic application task.

Basically, projects which only contain an unsolicited task and no cyclic task are not permissible!

#### Inputs

Identifier <small>DIS code   data type</small>	Information/possible settings
HM_bEnable <a href="#">C02659/1</a>   BOOL	Request control of basic function
	TRUE If no other basic function is active, a change-over to the "Homing active" function state is effected and homing can be carried out via the control inputs.
	TRUE↔FALSE An active reference search is stopped, i. e. a change-over from the active "Homing active" function state via the "Drive is stopped" function state back to the basic state "Drive at standstill" is carried out.
HM_bActivateHoming <a href="#">C02659/2</a>   BOOL	Start homing/set home position directly
	TRUE Reference search is started in the homing mode selected ( <a href="#">C02640</a> ). In the homing mode "100: Set reference directly" no reference search is started, but the home position set in <a href="#">C02642</a> is directly accepted.
	TRUE↔FALSE Active reference search is completed/cancelled.
HM_bHomingMark <a href="#">C02659/3</a>   BOOL	Input for reference switch
	TRUE Reference switch is activated.
HM_bLoadHomePos <a href="#">C02659/4</a>   BOOL	Load home position
	FALSE↔TRUE The position applied to input <i>HM_dnHomePos_p</i> is accepted as home position.
HM_dnHomePos_p <a href="#">C02658</a>   DINT	Home position in [increments] for acceptance with <i>HM_bLoadHomePos</i>

Identifier DIS code   data type	Information/possible settings
HM_bResetHomePos <a href="#">C02659/5</a>   BOOL	Reset the "Reference known" status FALSE → TRUE The internal "Home position known" status is reset. • The status outputs <i>HM_bDone</i> and <i>HM_bHomePosAvailable</i> are reset to FALSE.
HM_dnSpeedOverride_n <a href="#">C02655</a>   DINT From V5.0	Value for speed override • Percentage multiplier for the currently active speed ( <a href="#">C02644</a> or <a href="#">C02646</a> ). • In the case of active homing, the speed override is always active and does not have to be activated separately. • Changes are accepted in each cycle. • $2^{30} \equiv 100\%$ of the speed parameterised in <a href="#">C02644</a> or <a href="#">C02646</a> . • For values $\leq 1\%$ the status bit 19 is set. • Values $\leq 0\%$ are set to 0% internally and lead to the standstill of the drive.

### Outputs

Identifier DIS code   data type	Value/meaning
HM_dnState <a href="#">C02657</a>   DINT	Status (bit coded) • When the basic function is not enabled, all bits are set to "0". • Bits which are not listed are not assigned with a status (always "0"). Bit 1 Reference search is active. Bit 2 Reference search is completed. Bit 3 Acceleration/deceleration phase is active. Bit 5 CCW rotation is active. Bit 7 Reference known. Bit 15 Fault in basic function active (group signal). Bit 16 Pre-switch-off (reference switch) has been detected. Bit 17 Touch probe/zero pulse has been detected. Bit 19 Speed override $\leq 1\%$ • This status is only available from software version V5.0. Bit 21 Profile data are limited by basic function " <a href="#">Limiter</a> ". Bit 22 Traversing direction is inhibited by basic function " <a href="#">Limiter</a> ". Bit 23 Abort by basic function " <a href="#">Limiter</a> ". Bit 25 Stopping is active. • Basic function is enabled for the first time but no referencing has been requested / is active yet or speed $\neq 0$ . Bit 30 Profile generation error.
HM_bEnabled <a href="#">C02659/6</a>   BOOL	Status signal "Basic function is enabled" TRUE Homing via the control inputs is possible. • The <i>HM_bEnable</i> enable input is set to TRUE and the controller is in the "Homing active" function state.
HM_bActive <a href="#">C02659/7</a>   BOOL	Status signal "Basic function is active" TRUE Reference search is active (the drive axis is moving).
HM_bDone <a href="#">C02659/8</a>   BOOL	Status signal "Basic function is ready" TRUE Reference search is completed. • Output is reset to FALSE when input <i>HM_bActivateHoming</i> is reset to FALSE.
HM_bHomePosAvailable <a href="#">C02659/9</a>   BOOL	Status signal "Home position is known" TRUE The drive knows the home position.



### 11.6.2 Parameter setting

- Parameterisation dialog in »Engineer«: Tab **Application parameters** → Dialog level *Overview* → *All basic functions* → *Homing*
- Short overview of the parameters for homing:

Parameters	Info
<a href="#">C02528</a>	Traversing range
<a href="#">C02640</a>	Homing mode
<a href="#">C02641</a>	Action after detect Home position
<a href="#">C02642</a>	Home position
<a href="#">C02643</a>	Homing: target position
<a href="#">C02644</a>	Homing: Speed 1
<a href="#">C02645</a>	Homing: Acceleration 1
<a href="#">C02646</a>	Homing: veloc. 2
<a href="#">C02647</a>	Homing: acceleration 2
<a href="#">C02648</a>	Homing: S-ramp time
<a href="#">C02649</a>	Homing: Torque limit
<a href="#">C02650</a>	Homing: Blocking time
<a href="#">C02651</a>	Homing: TP configuration
<a href="#">C02652</a>	Home pos. following mains switching
<a href="#">C02653</a>	Max. rot. ang. aft. mns. swtch.
<a href="#">C02656</a>	Actual position (homing)

### 11.6.2.1 Behaviour of the home position after mains switching

If the home position/information is also to be available after mains switching, the setting [C02652](#) = "1: Received" is required.

Another condition for keeping the home position/information after mains switching is the compliance with the maximum permissible angle of rotation of the encoder.

- The maximally permissible angle of rotation can be set in [C02653](#) in angular degree [°] with regard to the encoder shaft ( $360^\circ \equiv$  one encoder shaft rotation).



#### Note!

Due to the internal numerical format and the resolution of one encoder revolution according to [C00100](#), the position may not be reconstructed over the complete encoder range!

- The possible number of revolutions can be calculated as follows:  
Number of revolutions =  $2^{(31 - C00100)}$
- Example: For a standard multiturn absolute value encoder with an absolute display area of 4096 revolutions ( $\pm 2048$ ), a maximum position resolution of 20 bits per revolution can be used!

When resolvers or single-turn absolute value encoders are used and the mains is switched off (24 V supply off), the encoder may only be moved by  $\frac{1}{2}$  revolution since otherwise the home position will get lost due to the ambiguity of the encoder information.

When multipole resolvers ([C00080](#) > 1) are used, a renewed homing is required after mains switching due to the ambiguity of the evaluated position.

### 11.6.2.2 Homing mode

The zero position, also called reference, can be defined by a reference search or reference setting:

- In case of a reference search the drive travels according to a defined mode to detect the reference independently.
- In case of reference setting the reference is manually set when the drive has stopped.



#### Tip!

A reference search is mainly used in the case of continuously running systems, or if the traversing range or machine cycle of the drive cannot be represented in the display area of the encoder, e. g. if incremental encoders are used at the motor, or singleturn absolute value encoders or resolvers are used at the gearbox.

A reference is mainly set in systems/machines that bear the risk of collisions, or every time no homing can be executed (e.g. in case of a cross cutter having material in the machine).

- For reference setting, select the homing mode "100" in [C02640](#).
- For a reference search the homing modes 0..."15" are provided in [C02640](#).
  - For process descriptions see the chapter "[Overview of the Lenze homing modes](#)". ([432](#))
  - [From software version V3.0](#) according to the DS402 device profile, additionally the homing modes 1001"..."1035" are provided in [C02640](#). Process descriptions for these homing modes can be found in the chapter "[Overview of DS402 homing modes](#)". ([432](#))



#### Note!

##### Profile data switch-over

For the reference search, two profile data sets with different velocities and accelerations can be parameterised. Like this, the homing time can be reduced, and at the same time accuracy can be increased.

▶ [Profile data switch-over](#) ([429](#))

The process descriptions in the following chapters provide information on the time the change-over to the profile data set 2 takes place in the corresponding homing mode.

▶ [Overview of the Lenze homing modes](#) ([432](#))

▶ [Overview of DS402 homing modes](#) ([445](#))

If the speed 2 ([C02646](#)) is set to "0" (Lenze setting), no change-over to the profile data set 2 takes place and the reference search and positioning to the target position is only executed with the profile parameters of the profile data set 1.



#### Note!

##### Drive behaviour after setting the reference

[From software version V4.0 onwards](#), [C02641](#) serves to parameterise the drive behaviour after setting the home position.

▶ [Drive behaviour after setting the home position](#) ([428](#))

In the Lenze setting ([C02641](#) = "0"), the drive traverses to the absolute target position set in [C02643](#) similarly to the behaviour known from the previous versions.

**Note!****Conditions for new homing**

A new homing must not be started if

- the drive is between a software and hardware limit position at the starting time and
- is to move towards the hardware limit position.

For the described case, the old homing must be reset first.

**11.6.2.3 Home position & target position**

When the home position is set during the reference search, the position detected in the machine measuring system corresponds to the value set in [C02642](#).

For software versions lower than V4.0 the following applies:

- Afterwards the drive travels to the target position set in [C02643](#).

The following applies from software version V4.0:

- The subsequent drive behaviour is determined by the mode parameterised in [C02641](#). See the below chapter "[Drive behaviour after setting the home position](#)".

**11.6.2.4 Drive behaviour after setting the home position**

This function extension is available from software version V4.0!

---

[C02641](#) can be used to select the drive behaviour after setting the home position.

**Selection "0: Move absolute on Target position"**

After setting the home position ([C02642](#)), the drive moves to the absolute target position set in [C02643](#).

This selection is the Lenze setting and corresponds to the behaviour known from the previous versions.

**Selection "1: Move relative by Target position"**

After setting the home position ([C02642](#)), the drive moves relatively by the target position set in [C02643](#).

**Selection "2: Stop immediately"**

After setting the home position ([C02642](#)), the drive stops immediately.

### 11.6.2.5 Profile data switch-over

For the reference search two profile data sets can be parameterised to reduce the homing time and increase the accuracy:

Profile data set 1		Profile data set 2	
<a href="#">C02644</a>	Speed 1	<a href="#">C02646</a>	Speed 2
<a href="#">C02645</a>	Acceleration 1 (and deceleration 1)	<a href="#">C02647</a>	Acceleration 2 (and deceleration 2)
<a href="#">C02648</a>	S-ramp time (identical in the two profile data sets) ▶ <a href="#">Setting the S-ramp time</a> (📖 387)	<a href="#">C02648</a>	S-ramp time (identical in the two profile data sets) ▶ <a href="#">Setting the S-ramp time</a> (📖 387)

- With the profile data set 1 first the limit switch/reference switch (depending on the mode selected) is quickly approached.
- After reversing on the limit switch/reference switch, the slower – but more accurate – approach of the encoder zero pulse/touch probe sensor and the positioning to the target position ([C02643](#)) are effected with profile data set 2.



#### Note!

The change-over to profile data set 2 is only effected if speed 2 ([C02646](#)) is set > "0"!

In the Lenze setting ([C02646](#) = "0") no change-over to the profile data set 2 takes place and the reference search and positioning to the target position is only executed with the profile parameters of the profile data set 1.

The process descriptions of the homing modes provide information about when the change-over to profile data set 2 takes place in the respective homing mode. ▶ [Overview of the Lenze homing modes](#) (📖 432)

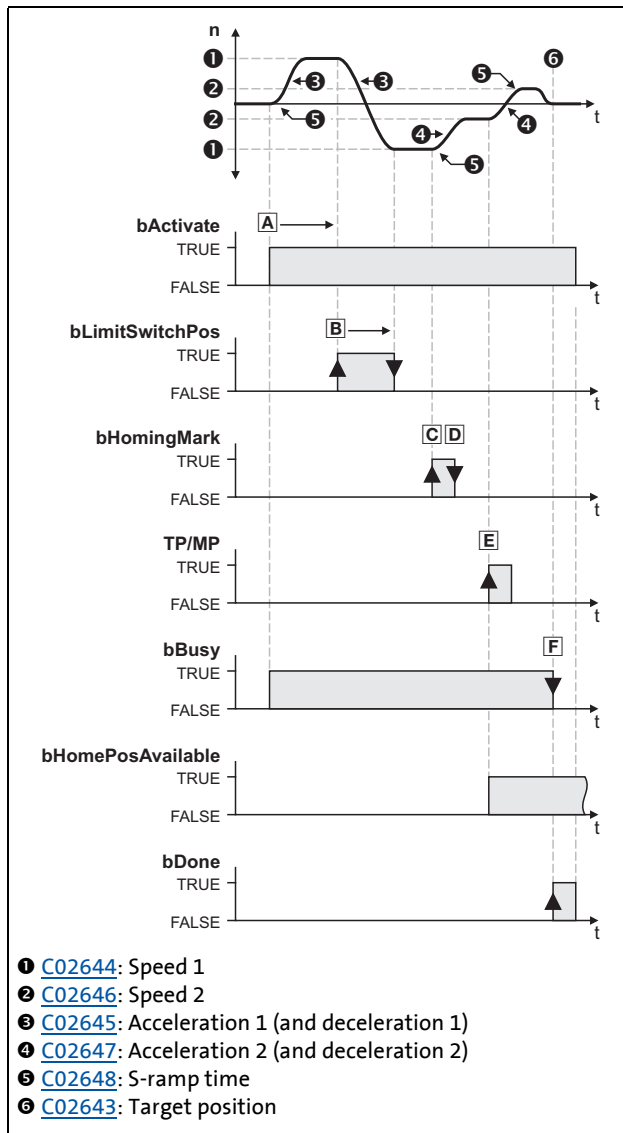

**Example: Procedure of mode 2:**

- A. Movement in positive direction with profile data set 1.
- B. Reversing to positive travel range limit switch.
- C. Positive edge at *HM\_bHomingMark* activates profile data set 2 for the further reference search.
- D. Negative edge at *HM\_bHomingMark* enables home position detection.
- E. The following positive edge of the encoder zero pulse (MP) sets the reference.
- F. Drive has reached defined target position.

### 11.6.2.6 Homing to end stop

By selecting the homing modes 14 & 15, homing to end stop can be executed as follows:

1. The drive travels with reduced torque in positive direction (mode 14) or negative direction (mode 15).
2. When the drive hits an end stop so that the torque limit set in [C02649](#) is exceeded for the blocking time defined in [C02650](#), the reference is set.
  - If a reference offset is set, traversing takes place around this offset in a correctly signed manner.

▶ [Mode 14: positive direction to torque limit](#) (📖 443)

▶ [Mode 15: negative direction to torque limit](#) (📖 443)

### 11.6.2.7 Reference switch connection

For the homing modes with reference switch, the *HM\_bHomingMark* control input must be connected to the digital input which is connected to the reference switch.

### 11.6.2.8 Touch probe interface configuration

The touch probe channel to be used for homing with touch probe detection in »Engineer« is selected on the **Application parameters** tab in the dialog level *Overview* → *All basic functions* → *Homing* → *TP interface*.

- The setting carried out in this parameterisation dialog directly affects the setting of [C02651](#) ("Homing: TP configuration") and vice versa.
- For directly setting [C02651](#) (e. g. by means of the keypad) the corresponding decimal values are listed for all configuration options in the following table:

Selection Touch probe channel	Touch probe response		
	Positive edge	Negative edge	Both edges
Digital input 1	1	2	3
Digital input 2	4	8	12
Digital input 3	16	32	48
Digital input 4	64	128	192
Digital input 5	256	512	768
Digital input 6	1024	2048	3072
Digital input 7	4096	8192	12288
Digital input 8	16384	32768	49152
Motor encoder zero pulse	65536		
Position encoder zero pulse	262144		

- Example: For selecting the touch probe channel "Digital input 1" and a response only to a negative edge, the decimal value "2" has to be set in [C02651](#).

### 11.6.3 Overview of the Lenze homing modes

In the following subchapters the procedures of homing modes 0 ... 15 are described, which can be selected in [C02640](#).

Homing mode <a href="#">C02640</a>	Evaluated signals/sensors			Reference switch at <i>HM_bHomingMark</i>
	Touch probe sensor/ encoder zero pulse	Travel range limit switch		
		Negative limit switch	Positive limit switch	
0	<input checked="" type="checkbox"/>			<input checked="" type="checkbox"/>
1	<input checked="" type="checkbox"/>			<input checked="" type="checkbox"/>
2	<input checked="" type="checkbox"/>		<input checked="" type="checkbox"/>	<input checked="" type="checkbox"/>
3	<input checked="" type="checkbox"/>	<input checked="" type="checkbox"/>		<input checked="" type="checkbox"/>
4	<input checked="" type="checkbox"/>			<input checked="" type="checkbox"/>
5	<input checked="" type="checkbox"/>			<input checked="" type="checkbox"/>
8	<input checked="" type="checkbox"/>			
9	<input checked="" type="checkbox"/>			
10	<input checked="" type="checkbox"/>		<input checked="" type="checkbox"/>	
11	<input checked="" type="checkbox"/>	<input checked="" type="checkbox"/>		
12			<input checked="" type="checkbox"/>	
13		<input checked="" type="checkbox"/>		
14	Positive direction of rotation to torque limit.			
15	Negative direction of rotation to torque limit.			
100	Set reference directly.			

The switches/sensors are evaluated via the following internal interfaces:

Switch/sensor	Internal interface for digital input signal
Touch probe sensor	<i>DIGIN_bIn1 ... DIGIN_bIn8</i> • Alternatively the motor encoder or position encoder zero pulse can be evaluated. ▶ <a href="#">Touch probe interface configuration</a> (431)
Positive travel range limit switch	<i>LIM_bLimitSwitchPositive</i> (basic function " <a href="#">Limiter</a> ")
Negative travel range limit switch	<i>LIM_bLimitSwitchNegative</i> (basic function " <a href="#">Limiter</a> ")
Reference switch	<i>HM_bHomingMark</i> (basic function " <a href="#">Homing</a> ")



#### Note!

##### Profile data switch-over

For the reference search, two profile data sets with different velocities and accelerations can be parameterised. Like this, the homing time can be reduced, and at the same time accuracy can be increased.

▶ [Profile data switch-over](#) (429)

The following process descriptions give information about the time the change-over to the profile data set 2 takes place in the corresponding homing mode.

If the speed 2 ([C02646](#)) is set to "0" (Lenze setting), no change-over to the profile data set 2 takes place and the reference search and positioning to the target position is only executed with the profile parameters of the profile data set 1.





### Note!

#### Drive behaviour after setting the reference

From software version V4.0 onwards, [C02641](#) serves to parameterise the drive behaviour after setting the home position.

▶ [Drive behaviour after setting the home position](#) (☰ 428)

In the Lenze setting ([C02641](#) = "0"), the drive traverses to the absolute target position set in [C02643](#) similarly to the behaviour known from the previous versions.

#### Mode 0: pos. direction - via home mark - to TP

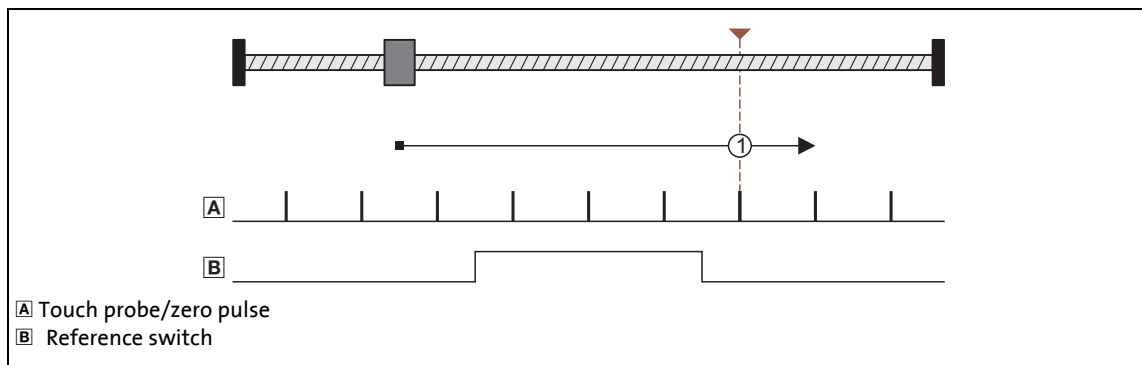

#### Procedure:

1. Movement in positive direction with profile data set 1.
2. Positive edge at *HM\_bHomingMark* activates profile data set 2 for the further reference search.
3. Negative edge at *HM\_bHomingMark* enables home position detection.
4. The following positive edge of the encoder zero pulse/touch probe sensor sets the reference.
5. Absolute positioning to target position ([C02643](#)) with profile data set 2 (if [C02641](#) = "0").

### Mode 1: neg. direction - via home mark - to TP

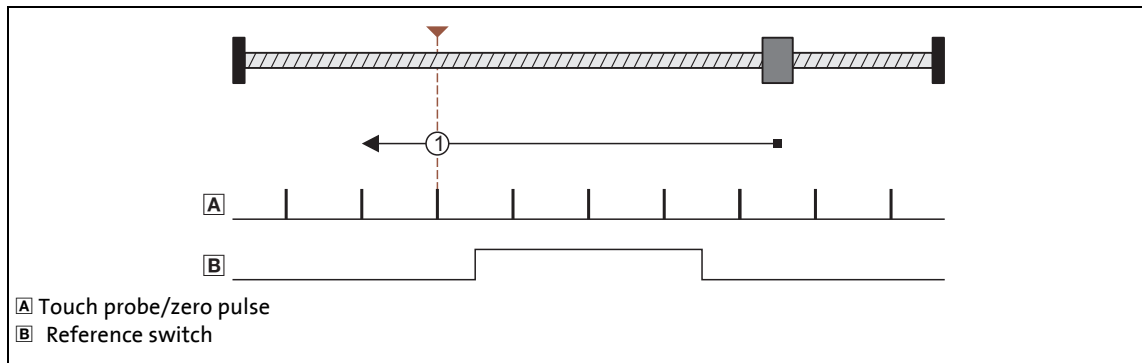

#### Procedure:

1. Movement in negative direction with profile data set 1.
2. Positive edge at *HM\_bHomingMark* activates profile data set 2 for the further reference search.
3. Negative edge at *HM\_bHomingMark* enables home position detection.
4. The following positive edge of the encoder zero pulse/touch probe sensor sets the reference.
5. Absolute positioning to target position ([C02643](#)) with profile data set 2 (if [C02641](#) = "0").

### Mode 2: pos. direction - reversing to limit switch - via home mark - to TP

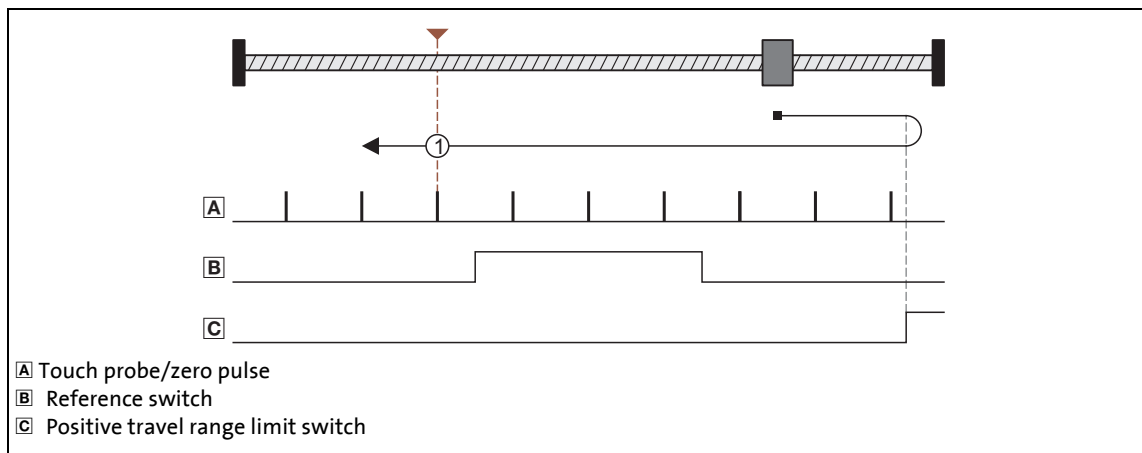

#### Procedure:

1. Movement in positive direction with profile data set 1.
2. Reversing to positive travel range limit switch.
3. Positive edge at *HM\_bHomingMark* activates profile data set 2 for the further reference search.
4. Negative edge at *HM\_bHomingMark* enables home position detection.
5. The following positive edge of the encoder zero pulse/touch probe sensor sets the reference.
6. Absolute positioning to target position ([C02643](#)) with profile data set 2 (if [C02641](#) = "0").

# 11 Basic drive functions

## 11.6 Homing

Mode 3: neg. direction - reversing to limit switch - via home mark - to TP

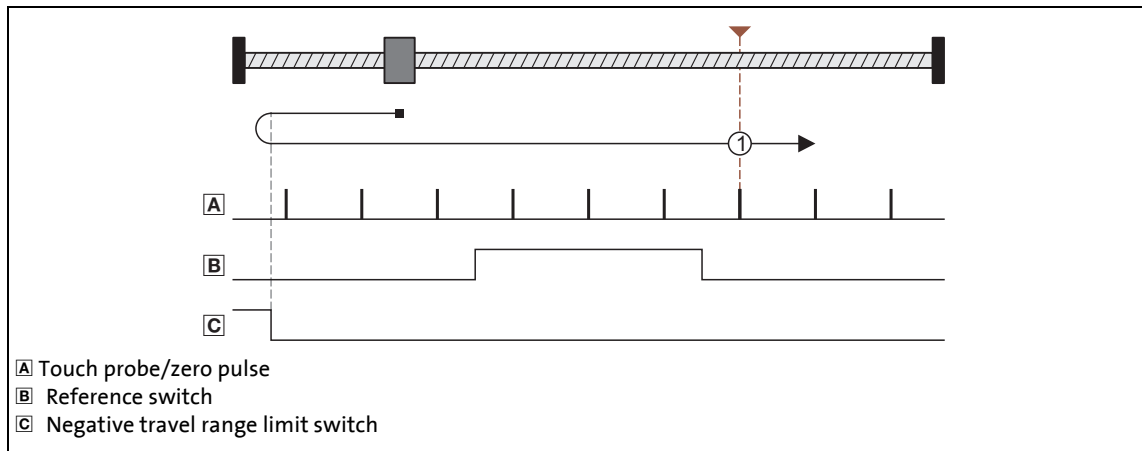

### Procedure:

1. Movement in negative direction with profile data set 1.
2. Reversing to negative travel range limit switch.
3. Positive edge at *HM\_bHomingMark* activates profile data set 2 for the further reference search.
4. Negative edge at *HM\_bHomingMark* enables home position detection.
5. The following positive edge of the encoder zero pulse/touch probe sensor sets the reference.
6. Absolute positioning to target position ([C02643](#)) with profile data set 2 (if [C02641](#) = "0").

### Mode 4: pos. direction - reversing to home mark - to TP

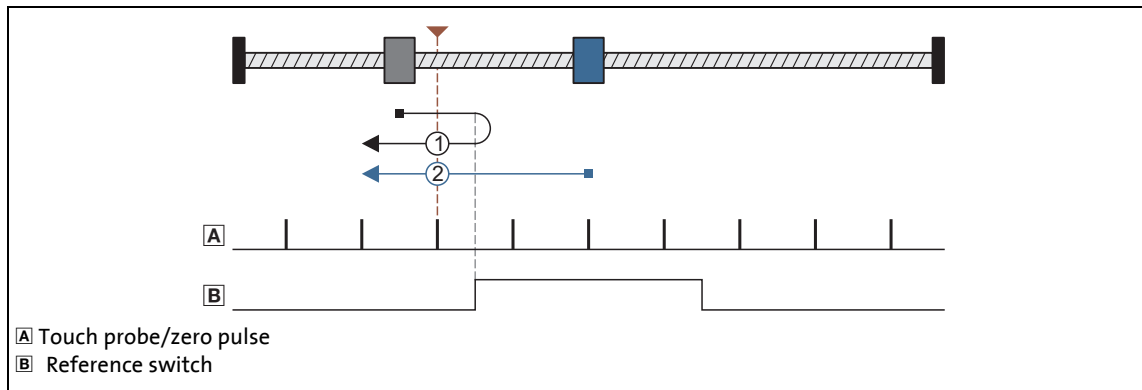

#### Procedures:

Case 1:

Axis has not activated reference switch yet:

1. Movement in positive direction with profile data set 1.
2. Reversing with positive edge at *HM\_bHomingMark* and simultaneous activation of the profile data set 2 for further reference search.
3. Negative edge at *HM\_bHomingMark* enables home position detection.
4. The following positive edge of the encoder zero pulse/touch probe sensor sets the reference.
5. Absolute positioning to target position ([C02643](#)) with profile data set 2 (if [C02641](#) = "0").

Case 2:

Axis is already positioned on reference switch:

1. Movement in negative direction with profile data set 2.
2. Negative edge at *HM\_bHomingMark* enables home position detection.
3. The following positive edge of the encoder zero pulse/touch probe sensor sets the reference.
4. Absolute positioning to target position ([C02643](#)) with profile data set 2 (if [C02641](#) = "0").

### Mode 5: neg. direction - reversing to home mark - to TP

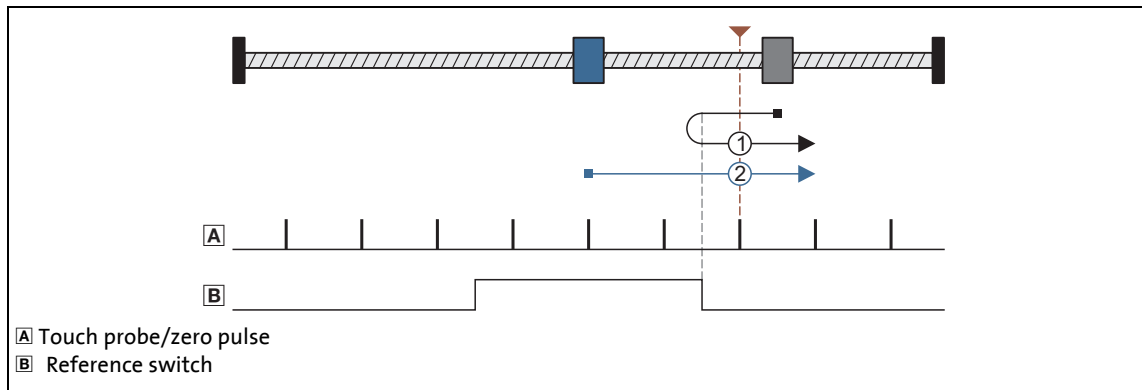

#### Procedures:

Case 1:

Axis has not activated reference switch yet:

1. Movement in negative direction with profile data set 1.
2. Reversing with positive edge at *HM\_bHomingMark* and simultaneous activation of the profile data set 2 for further reference search.
3. Negative edge at *HM\_bHomingMark* enables home position detection.
4. The following positive edge of the encoder zero pulse/touch probe sensor sets the reference.
5. Absolute positioning to target position ([C02643](#)) with profile data set 2 (if [C02641](#) = "0").

Case 2:

Axis is already positioned on reference switch:

1. Movement in positive direction with profile data set 2.
2. Negative edge at *HM\_bHomingMark* enables home position detection.
3. The following positive edge of the encoder zero pulse/touch probe sensor sets the reference.
4. Absolute positioning to target position ([C02643](#)) with profile data set 2 (if [C02641](#) = "0").

# 11 Basic drive functions

## 11.6 Homing

### Mode 8: positive direction to touch probe

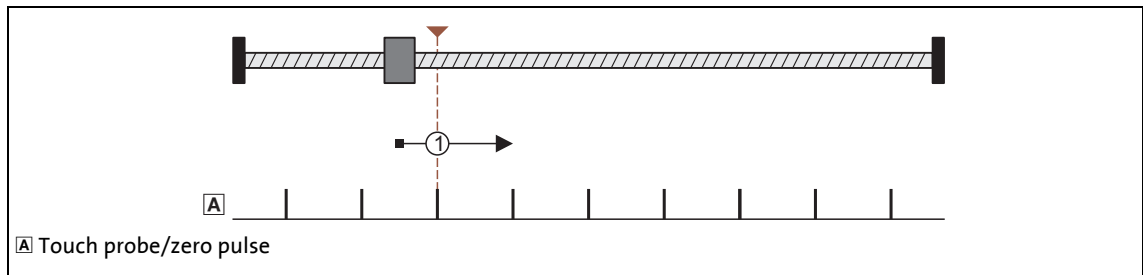

#### Procedure:

1. Movement in positive direction with profile data set 1.
2. The following positive edge of the touch probe sensor sets the reference.
3. Absolute positioning to target position ([C02643](#)) with profile data set 2 (if [C02641](#) = "0").

### Mode 9: negative direction to touch probe

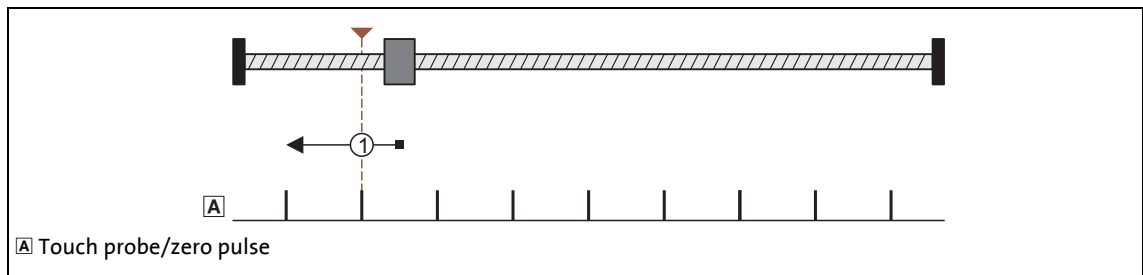

#### Procedure:

1. Movement in negative direction with profile data set 1.
2. The following positive edge of the touch probe sensor sets the reference.
3. Absolute positioning to target position ([C02643](#)) with profile data set 2 (if [C02641](#) = "0").

### Mode 10: pos. direction - reversing to limit switch - to TP

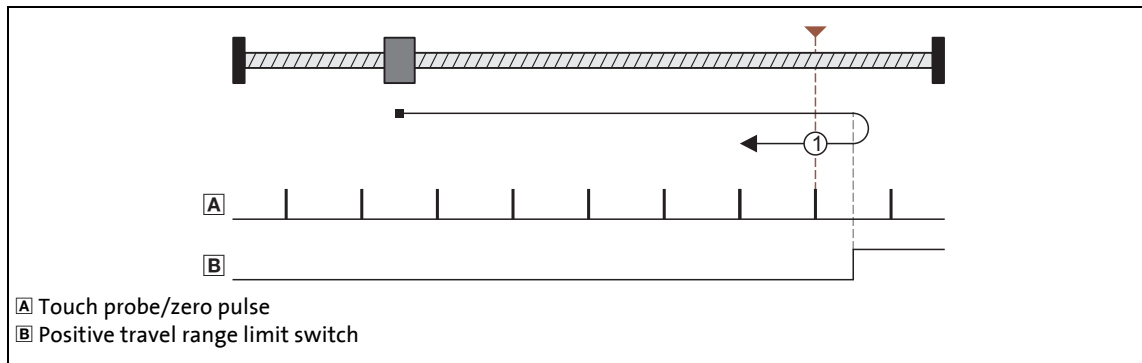

#### Procedure:

1. Movement in positive direction with profile data set 1.
2. Reversing when the edge of the positive travel range limit switch is positive and, at the same time, activation of profile data set 2 for continued reference searching.
3. The touch probe signal is evaluated while reversing the limit switch.
4. The following positive edge of the touch probe sensor sets the reference.
5. Absolute positioning to target position ([C02643](#)) with profile data set 2 (if [C02641](#) = "0").



#### Note!

The touch probe detection is already activated after reversing to the travel range limit switch, i.e. the home position may be set to the travel range limit switch.

- We therefore recommend to set a target position ([C02643](#)) unequal to the home position ([C02642](#)), in order to reenble the activated limit switch. Otherwise, the positioning process to the target position may be aborted by the basic function "[Limiter](#)" (see status signal *HM\_dnState*).
- We recommend the use of the DS402 homing methods 1 and 2 if the touch probe detection (especially the one of the motor zero pulse) is to be activated after the travel range switch has been left. ▶ [Overview of DS402 homing modes](#) ([book 445](#))

### Mode 11: neg. direction - reversing to limit switch - to TP

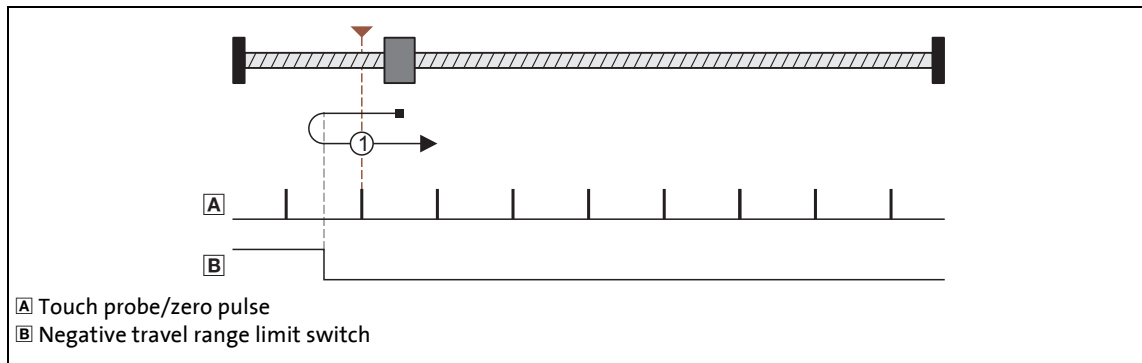

#### Procedure:

1. Movement in negative direction with profile data set 1.
2. Reversing when the edge of the negative travel range limit switch is positive and, at the same time, activation of profile data set 2 for continued reference searching.
3. The touch probe signal is evaluated while reversing the limit switch.
4. The following positive edge of the touch probe sensor sets the reference.
5. Absolute positioning to target position ([C02643](#)) with profile data set 2 (if [C02641](#) = "0").



#### Note!

The touch probe detection is already activated after reversing to the travel range limit switch, i.e. the home position may be set to the travel range limit switch.

- We therefore recommend to set a target position ([C02643](#)) unequal to the home position ([C02642](#)), in order to reenble the activated limit switch. Otherwise, the positioning process to the target position may be aborted by the basic function "[Limiter](#)" (see status signal *HM\_dnState*).
- We recommend the use of the DS402 homing methods 1 and 2 if the touch probe detection (especially the one of the motor zero pulse) is to be activated after the travel range switch has been left. ▶ [Overview of DS402 homing modes](#) (445)



### Mode 12: positive direction to limit switch

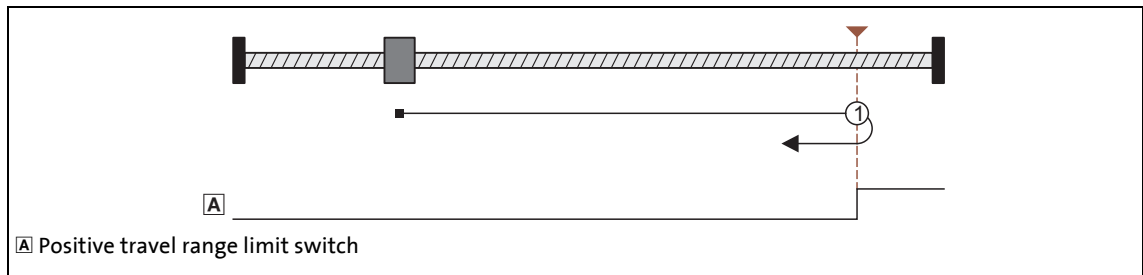

#### Procedure:

1. Movement in positive direction with profile data set 1.
2. Positive edge of the travel range limit switch sets reference.
3. Absolute positioning to target position ([C02643](#)) with profile data set 2 (if [C02641](#) = "0").



#### Note!

The load machine can also leave the travel range limit switch. There follows a return to the home position that was set with the positive edge of the travel range limit switch.

- It is possible that, as a result, the machine will remain on an operated limit switch.
- Therefore it is recommended to set a target position ([C02643](#)) that is unequal to the home position ([C02642](#)) to release the activated limit switch again.

---

## Mode 13: negative direction to limit switch

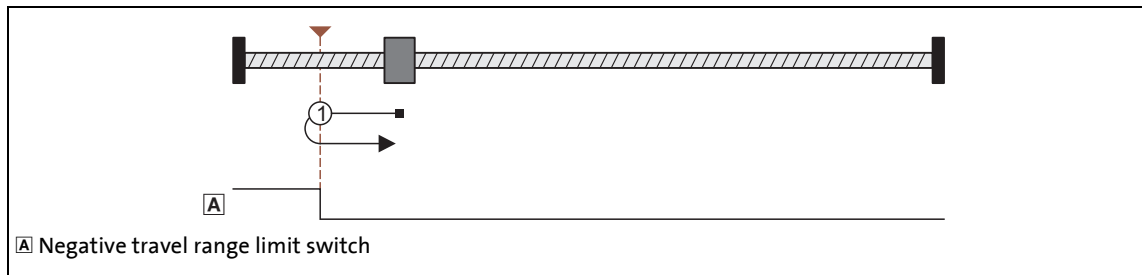

### Procedure:

1. Movement in negative direction with profile data set 1.
2. Positive edge of the travel range limit switch sets reference.
3. Absolute positioning to target position ([C02643](#)) with profile data set 2 (if [C02641](#) = "0").



### Note!

The load machine can also leave the travel range limit switch. There follows a return to the home position that was set with the positive edge of the travel range limit switch.

- It is possible that, as a result, the machine will remain on an operated limit switch.
- Therefore it is recommended to set a target position ([C02643](#)) that is unequal to the home position ([C02642](#)) to release the activated limit switch again.

### Mode 14: positive direction to torque limit

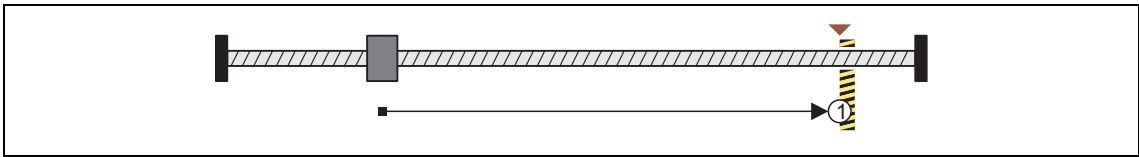

#### Procedure:

1. Movement in positive direction with reduced torque and profile data set 1.
2. The reference is set if the two following conditions for the time set in [C02650](#) are fulfilled at the same time:
  - The current speed is lower than the threshold for standstill detection set in [C00019](#).
  - Current torque is greater than the torque limit set in [C02649](#) ("Homing to end stop").
3. Absolute positioning to target position ([C02643](#)) with profile data set 2 (if [C02641](#) = "0").

### Mode 15: negative direction to torque limit

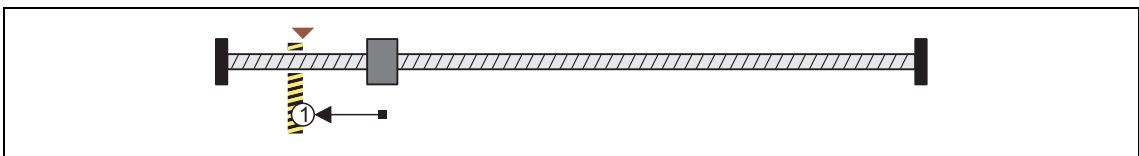

#### Procedure:

1. Movement in negative direction with reduced torque and profile data set 1.
2. The reference is set if the two following conditions for the time set in [C02650](#) are fulfilled at the same time:
  - The current speed is lower than the threshold for standstill detection set in [C00019](#).
  - Current torque is greater than the torque limit set in [C02649](#) ("Homing to end stop").
3. Absolute positioning to target position ([C02643](#)) with profile data set 2 (if [C02641](#) = "0").

# 11 Basic drive functions

## 11.6 Homing

---

### Mode 100: Set reference directly

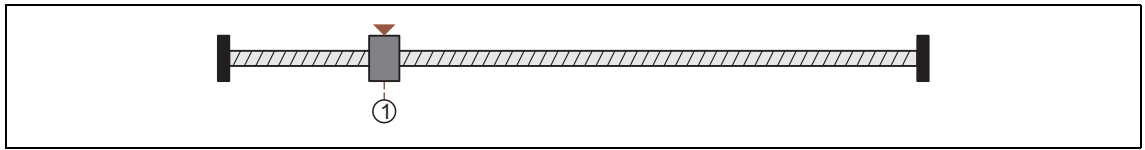

During the drive is at standstill, the measuring system is set by means of the home position parameterised in [C02642](#).

### 11.6.4 Overview of DS402 homing modes

This function extension is available from software version V3.0!

In addition to the homing modes described in the previous subchapter "[Overview of the Lenze homing modes](#)", from software version V3.0 also the homing modes described in the following can be selected for a homing in [C02640](#), according to the DS402 device profile.

DS402 homing method	Evaluated signals/sensors			Reference switch at <i>HM_bHomingMark</i>
	Touch probe sensor/ encoder zero pulse	Travel range limit switch		
		Negative limit switch	Positive limit switch	
01	<input checked="" type="checkbox"/>	<input checked="" type="checkbox"/>		
02	<input checked="" type="checkbox"/>		<input checked="" type="checkbox"/>	
03	<input checked="" type="checkbox"/>			<input checked="" type="checkbox"/>
04	<input checked="" type="checkbox"/>			<input checked="" type="checkbox"/>
05	<input checked="" type="checkbox"/>			<input checked="" type="checkbox"/>
06	<input checked="" type="checkbox"/>			<input checked="" type="checkbox"/>
07	<input checked="" type="checkbox"/>		<input checked="" type="checkbox"/>	<input checked="" type="checkbox"/>
08	<input checked="" type="checkbox"/>		<input checked="" type="checkbox"/>	<input checked="" type="checkbox"/>
09	<input checked="" type="checkbox"/>		<input checked="" type="checkbox"/>	<input checked="" type="checkbox"/>
10	<input checked="" type="checkbox"/>		<input checked="" type="checkbox"/>	<input checked="" type="checkbox"/>
11	<input checked="" type="checkbox"/>	<input checked="" type="checkbox"/>		<input checked="" type="checkbox"/>
12	<input checked="" type="checkbox"/>	<input checked="" type="checkbox"/>		<input checked="" type="checkbox"/>
13	<input checked="" type="checkbox"/>	<input checked="" type="checkbox"/>		<input checked="" type="checkbox"/>
14	<input checked="" type="checkbox"/>	<input checked="" type="checkbox"/>		<input checked="" type="checkbox"/>
15	Reserved: no homing is executed.			
16	Reserved: no homing is executed.			
17		<input checked="" type="checkbox"/>		
18			<input checked="" type="checkbox"/>	
19				<input checked="" type="checkbox"/>
20				<input checked="" type="checkbox"/>
21				<input checked="" type="checkbox"/>
22				<input checked="" type="checkbox"/>
23			<input checked="" type="checkbox"/>	<input checked="" type="checkbox"/>
24			<input checked="" type="checkbox"/>	<input checked="" type="checkbox"/>
25			<input checked="" type="checkbox"/>	<input checked="" type="checkbox"/>
26			<input checked="" type="checkbox"/>	<input checked="" type="checkbox"/>
27		<input checked="" type="checkbox"/>		<input checked="" type="checkbox"/>
28		<input checked="" type="checkbox"/>		<input checked="" type="checkbox"/>
29		<input checked="" type="checkbox"/>		<input checked="" type="checkbox"/>
30		<input checked="" type="checkbox"/>		<input checked="" type="checkbox"/>
31	Reserved: no homing is executed.			
32	Reserved: no homing is executed.			
33	<input checked="" type="checkbox"/>			
34	<input checked="" type="checkbox"/>			
35	Direct reference setting.			

The switches/sensors are evaluated via the following internal interfaces:

Switch/sensor	Internal interface for digital input signal
Touch probe sensor	<i>DIGIN_bIn1 ... DIGIN_bIn8</i> <ul style="list-style-type: none"> <li>Alternatively the motor encoder or position encoder zero pulse can be evaluated.</li> </ul> <a href="#">▶ Touch probe interface configuration (□ 431)</a>
Positive travel range limit switch	<i>LIM_bLimitSwitchPositive</i> (basic function " <a href="#">Limiter</a> ")
Negative travel range limit switch	<i>LIM_bLimitSwitchNegative</i> (basic function " <a href="#">Limiter</a> ")
Reference switch	<i>HM_bHomingMark</i> (basic function " <a href="#">Homing</a> ")



## Note!

### Profile data switch-over

For the reference search, two profile data sets with different velocities and accelerations can be parameterised. Like this, the homing time can be reduced, and at the same time accuracy can be increased.

▶ [Profile data switch-over \(□ 429\)](#)

The following process descriptions give information about the time the change-over to the profile data set 2 takes place in the corresponding homing mode.

If the speed 2 ([C02646](#)) is set to "0" (Lenze setting), no change-over to the profile data set 2 takes place and the reference search and positioning to the target position is only executed with the profile parameters of the profile data set 1.



## Note!

### Drive behaviour after setting the reference

From software version V4.0 onwards, [C02641](#) serves to parameterise the drive behaviour after setting the home position.

▶ [Drive behaviour after setting the home position \(□ 428\)](#)

In the Lenze setting ([C02641](#) = "0"), the drive traverses to the absolute target position set in [C02643](#) similarly to the behaviour known from the previous versions.

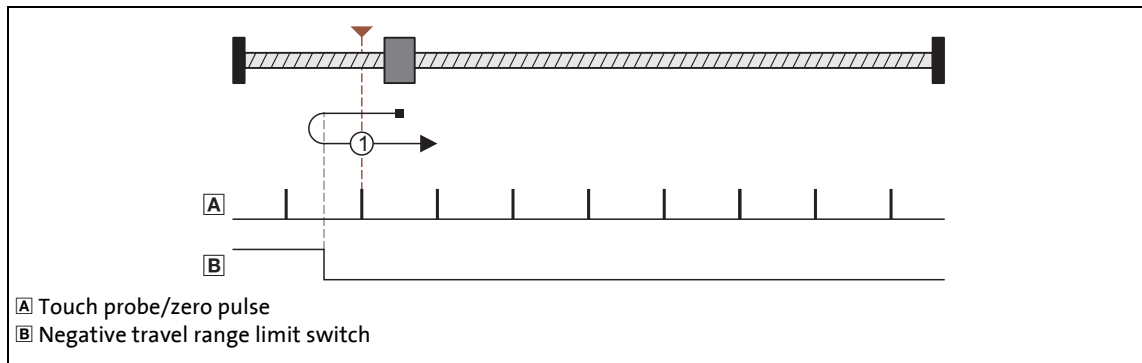
**Mode 1001: DS402 homing method 01****Procedure:**

1. Movement in negative direction with profile data set 1.
2. Reversing to negative travel range limit switch and change-over to profile data set 2.
3. Negative edge of the travel range limit switch activates touch probe recognition.
4. The following positive edge of the encoder zero pulse/touch probe sensor sets the reference.
5. Absolute positioning to target position ([C02643](#)) with profile data set 2 (if [C02641](#) = "0").

### Mode 1002: DS402 homing method 02

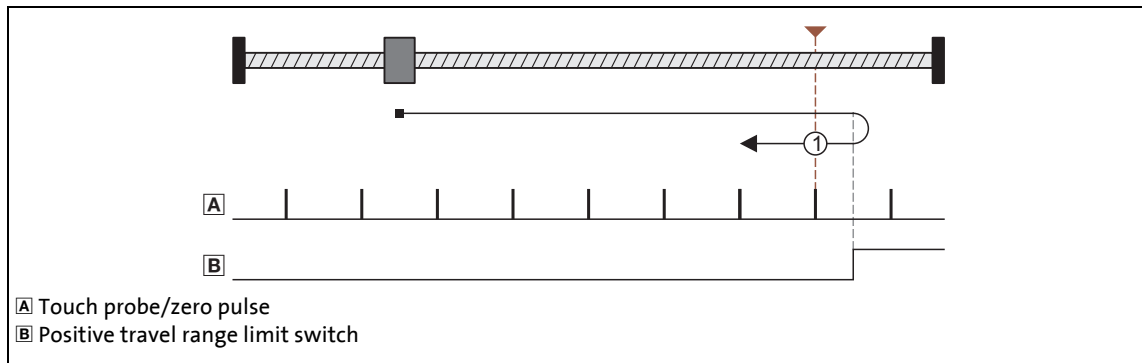

#### Procedure:

1. Movement in positive direction with profile data set 1.
2. Reversing to positive travel range limit switch and change-over to profile data set 2.
3. Negative edge of the travel range limit switch activates touch probe recognition.
4. The following positive edge of the encoder zero pulse/touch probe sensor sets the reference.
5. Absolute positioning to target position ([C02643](#)) with profile data set 2 (if [C02641](#) = "0").



### Mode 1003: DS402 homing method 03

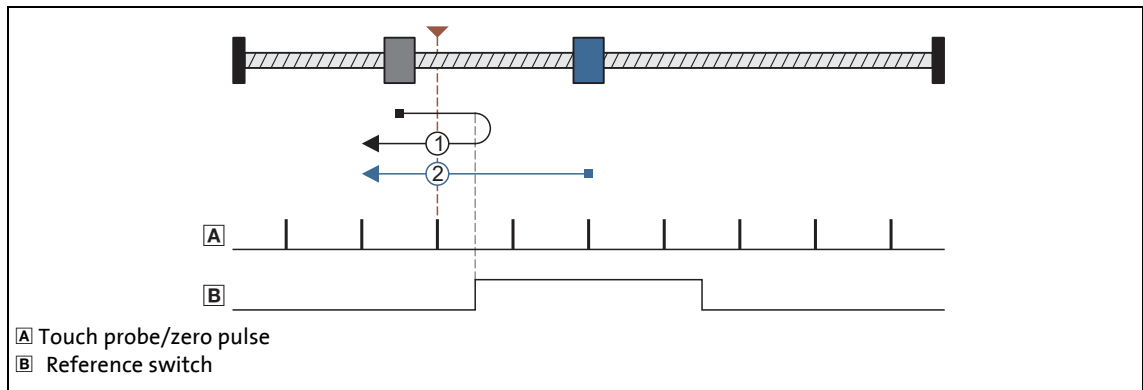

#### Procedures:

Case 1:

Axis has not activated reference switch yet:

1. Movement in positive direction with profile data set 1.
2. Reversing with positive edge of the reference switch and change-over to profile data set 2.
3. Negative edge of the reference switch activates touch probe recognition.
4. The following positive edge of the encoder zero pulse/touch probe sensor sets the reference.
5. Absolute positioning to target position ([C02643](#)) with profile data set 2 (if [C02641](#) = "0").

Case 2:

Axis is already positioned on reference switch:

1. Movement in negative direction with profile data set 2.
2. Negative edge of the reference switch activates touch probe recognition.
3. The following positive edge of the encoder zero pulse/touch probe sensor sets the reference.
4. Absolute positioning to target position ([C02643](#)) with profile data set 2 (if [C02641](#) = "0").

### Mode 1004: DS402 homing method 04

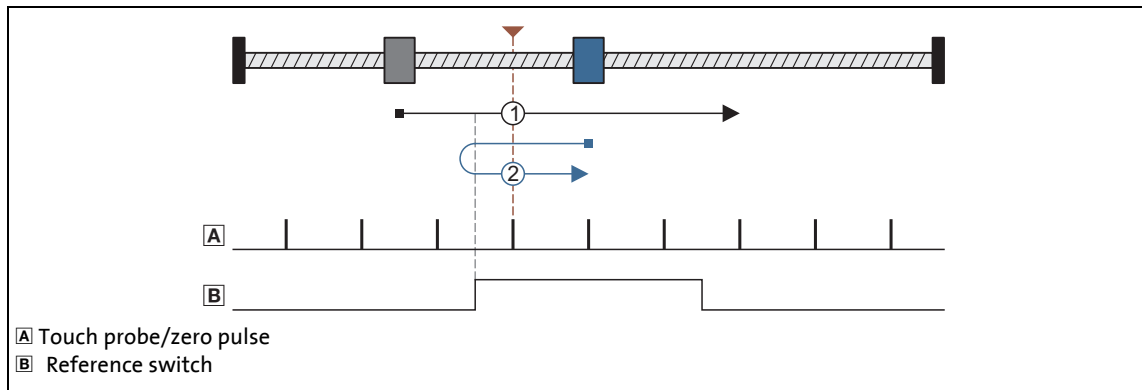

#### Procedures:

Case 1:

Axis has not activated reference switch yet:

1. Movement in positive direction with profile data set 1.
2. Positive edge of the reference switch activates touch probe detection and change to profile data set 2.
3. The following positive edge of the encoder zero pulse/touch probe sensor sets the reference.
4. Absolute positioning to target position ([C02643](#)) with profile data set 2 (if [C02641](#) = "0").

Case 2:

Axis is already positioned on reference switch:

1. Movement in negative direction with profile data set 2.
2. Reversing with negative edge of the reference switch.
3. Positive edge of the reference switch activates touch probe detection.
4. The following positive edge of the encoder zero pulse/touch probe sensor sets the reference.
5. Absolute positioning to target position ([C02643](#)) with profile data set 2 (if [C02641](#) = "0").

### Mode 1005: DS402 homing method 05

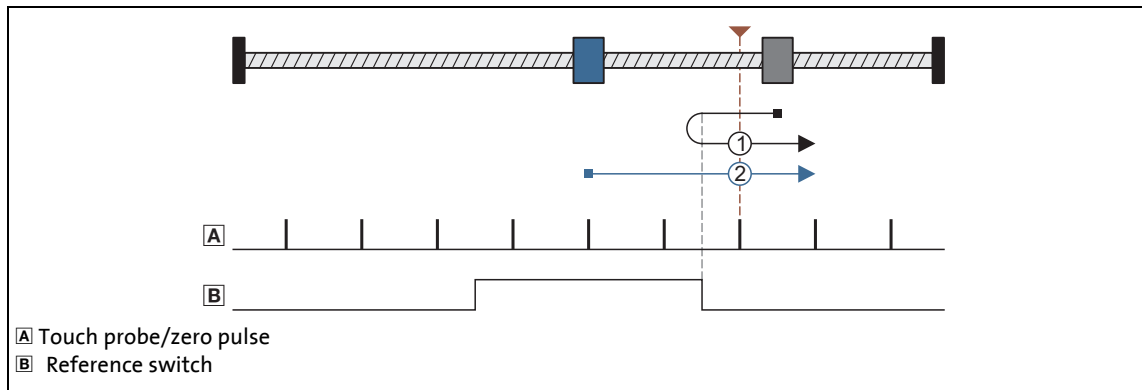

#### Procedures:

Case 1:

Axis has not activated reference switch yet:

1. Movement in negative direction with profile data set 1.
2. Reversing with positive edge of the reference switch and change-over to profile data set 2.
3. Negative edge of the reference switch activates touch probe recognition.
4. The following positive edge of the encoder zero pulse/touch probe sensor sets the reference.
5. Absolute positioning to target position ([C02643](#)) with profile data set 2 (if [C02641](#) = "0").

Case 2:

Axis is already positioned on reference switch:

1. Movement in positive direction with profile data set 2.
2. Negative edge of the reference switch activates touch probe recognition.
3. The following positive edge of the encoder zero pulse/touch probe sensor sets the reference.
4. Absolute positioning to target position ([C02643](#)) with profile data set 2 (if [C02641](#) = "0").

### Mode 1006: DS402 homing method 06

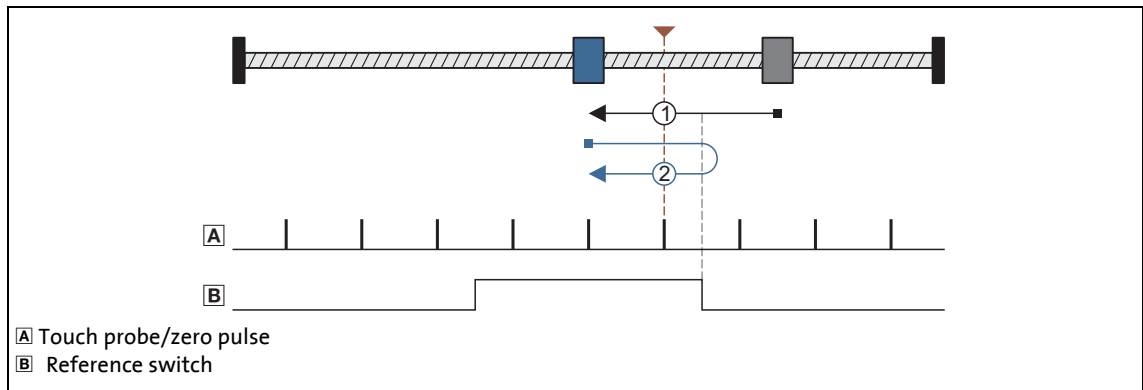

#### Procedures:

Case 1:

Axis has not activated reference switch yet:

1. Movement in negative direction with profile data set 1.
2. Positive edge of the reference switch activates touch probe detection and change to profile data set 2.
3. The following positive edge of the encoder zero pulse/touch probe sensor sets the reference.
4. Absolute positioning to target position ([C02643](#)) with profile data set 2 (if [C02641](#) = "0").

Case 2:

Axis is already positioned on reference switch:

1. Movement in positive direction with profile data set 2.
2. Reversing with negative edge of the reference switch.
3. Positive edge of the reference switch activates touch probe detection.
4. The following positive edge of the encoder zero pulse/touch probe sensor sets the reference.
5. Absolute positioning to target position ([C02643](#)) with profile data set 2 (if [C02641](#) = "0").

### Mode 1007: DS402 homing method 07

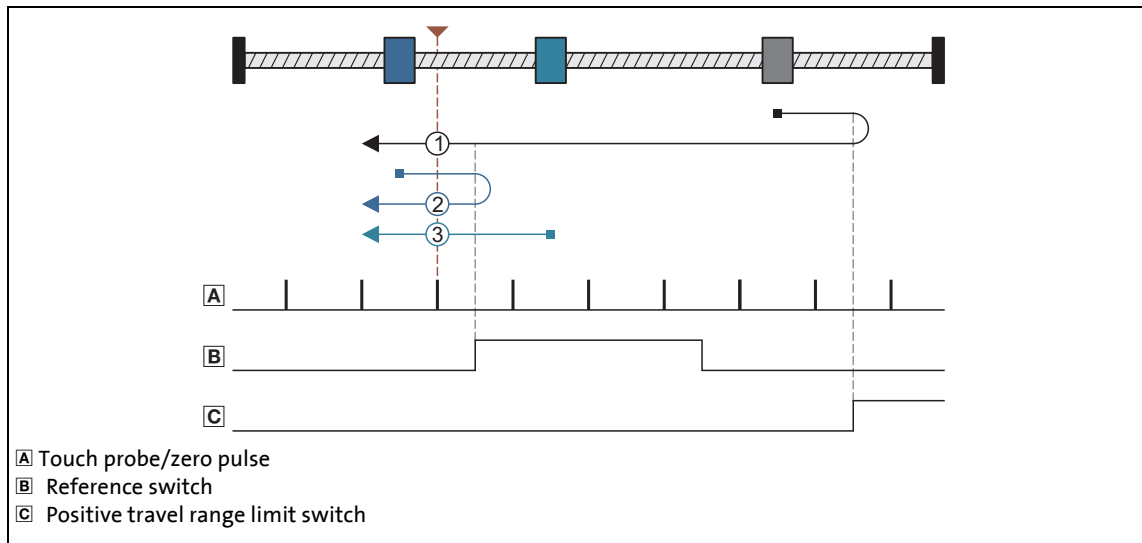

#### Procedures:

- Case 1: Axis does not activate the reference switch while moving towards the limit switch:
1. Movement in positive direction with profile data set 1.
  2. Reversing to positive travel range limit switch.
  3. Positive edge of the reference switch activates profile data set 2.
  4. Negative edge of the reference switch activates touch probe recognition.
  5. The following positive edge of the encoder zero pulse/touch probe sensor sets the reference.
  6. Absolute positioning to target position ([C02643](#)) with profile data set 2 (if [C02641](#) = "0").
- Case 2: Axis first activates the reference switch while moving towards the limit switch:
1. Movement in positive direction with profile data set 1.
  2. Reversing with positive edge of the reference switch and change-over to profile data set 2.
  3. Negative edge of the reference switch activates touch probe recognition.
  4. The following positive edge of the encoder zero pulse/touch probe sensor sets the reference.
  5. Absolute positioning to target position ([C02643](#)) with profile data set 2 (if [C02641](#) = "0").

# 11 Basic drive functions

## 11.6 Homing

Case 3: Axis is already positioned on reference switch:

1. Movement in negative direction with profile data set 2.
2. Negative edge of the reference switch activates touch probe recognition.
3. The following positive edge of the encoder zero pulse/touch probe sensor sets the reference.
4. Absolute positioning to target position ([C02643](#)) with profile data set 2 (if [C02641](#) = "0").

### Mode 1008: DS402 homing method 08

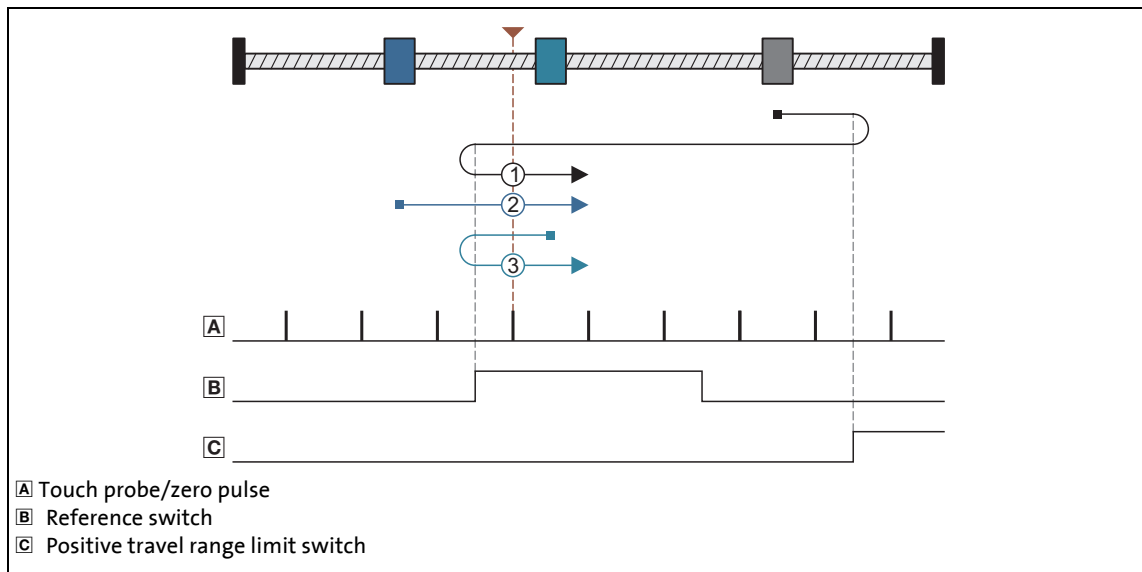

### Procedures:

Case 1: Axis does not activate the reference switch while moving towards the limit switch:

1. Movement in positive direction with profile data set 1.
2. Reversing to positive travel range limit switch.
3. Positive edge of the reference switch activates profile data set 2.
4. Reversing with negative edge of the reference switch.
5. Positive edge of the reference switch activates touch probe detection.
6. The following positive edge of the encoder zero pulse/touch probe sensor sets the reference.
7. Absolute positioning to target position ([C02643](#)) with profile data set 2 (if [C02641](#) = "0").

# 11 Basic drive functions

## 11.6 Homing

---

Case 2: Axis first activates the reference switch while moving towards the limit switch:

1. Movement in positive direction with profile data set 1.
2. Positive edge of the reference switch activates touch probe detection and change to profile data set 2.
3. The following positive edge of the encoder zero pulse/touch probe sensor sets the reference.
4. Absolute positioning to target position ([C02643](#)) with profile data set 2 (if [C02641](#) = "0").

Case 3: Axis is already positioned on reference switch:

1. Movement in negative direction with profile data set 2.
2. Reversing with negative edge of the reference switch.
3. Positive edge of the reference switch activates touch probe detection.
4. The following positive edge of the encoder zero pulse/touch probe sensor sets the reference.
5. Absolute positioning to target position ([C02643](#)) with profile data set 2 (if [C02641](#) = "0").

### Mode 1009: DS402 homing method 09

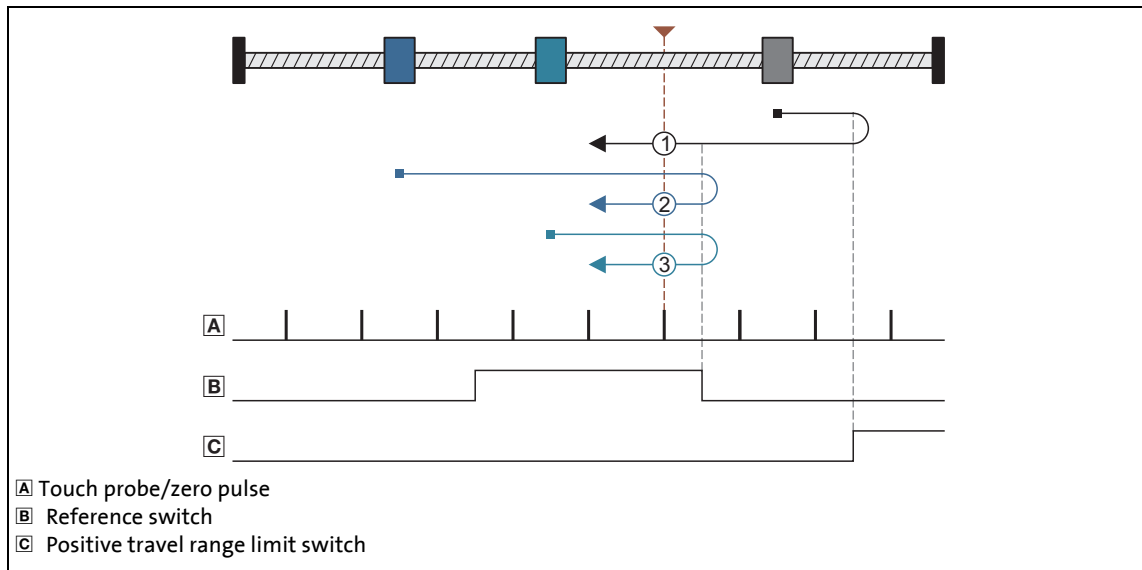

#### Procedures:

- Case 1: Axis does not activate the reference switch while moving towards the limit switch:
1. Movement in positive direction with profile data set 1.
  2. Reversing to positive travel range limit switch.
  3. Positive edge of the reference switch activates touch probe detection and change to profile data set 2.
  4. The following positive edge of the encoder zero pulse/touch probe sensor sets the reference.
  5. Absolute positioning to target position (C02643) with profile data set 2 (if C02641 = "0").
- Case 2: Axis first activates the reference switch while moving towards the limit switch:
1. Movement in positive direction with profile data set 1.
  2. Positive edge of the reference switch activates profile data set 2.
  3. Reversing with negative edge of the reference switch.
  4. Positive edge of the reference switch activates touch probe detection.
  5. The following positive edge of the encoder zero pulse/touch probe sensor sets the reference.
  6. Absolute positioning to target position (C02643) with profile data set 2 (if C02641 = "0").
- Case 3: Axis is already positioned on reference switch:
1. Movement in positive direction with profile data set 2.
  2. Reversing with negative edge of the reference switch.
  3. Positive edge of the reference switch activates touch probe detection.
  4. The following positive edge of the encoder zero pulse/touch probe sensor sets the reference.
  5. Absolute positioning to target position (C02643) with profile data set 2 (if C02641 = "0").



### Mode 1010: DS402 homing method 10

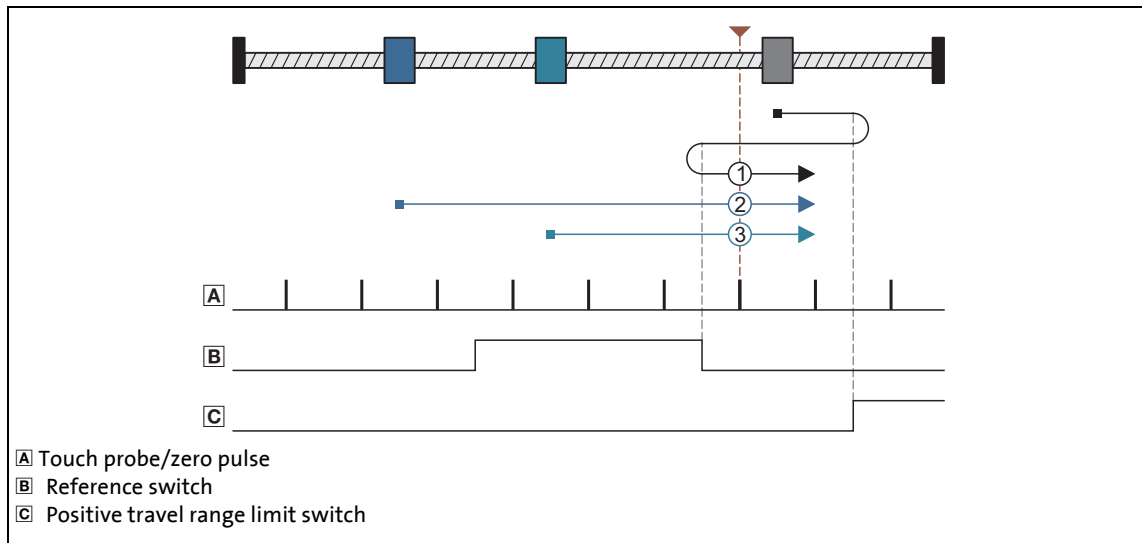

#### Procedures:

- Case 1: Axis does not activate the reference switch while moving towards the limit switch:
1. Movement in positive direction with profile data set 1.
  2. Reversing to positive travel range limit switch.
  3. Reversing with positive edge of the reference switch and change-over to profile data set 2.
  4. Negative edge of the reference switch activates touch probe recognition.
  5. The following positive edge of the encoder zero pulse/touch probe sensor sets the reference.
  6. Absolute positioning to target position ([C02643](#)) with profile data set 2 (if [C02641](#) = "0").
- Case 2: Axis first activates the reference switch while moving towards the limit switch:
1. Movement in positive direction with profile data set 1.
  2. Negative edge of the reference switch activates touch probe recognition.
  3. The following positive edge of the encoder zero pulse/touch probe sensor sets the reference.
  4. Absolute positioning to target position ([C02643](#)) with profile data set 2 (if [C02641](#) = "0").
- Case 3: Axis is already positioned on reference switch:
1. Movement in positive direction with profile data set 2.
  2. Negative edge of the reference switch activates touch probe recognition.
  3. The following positive edge of the encoder zero pulse/touch probe sensor sets the reference.
  4. Absolute positioning to target position ([C02643](#)) with profile data set 2 (if [C02641](#) = "0").

### Mode 1011: DS402 homing method 11

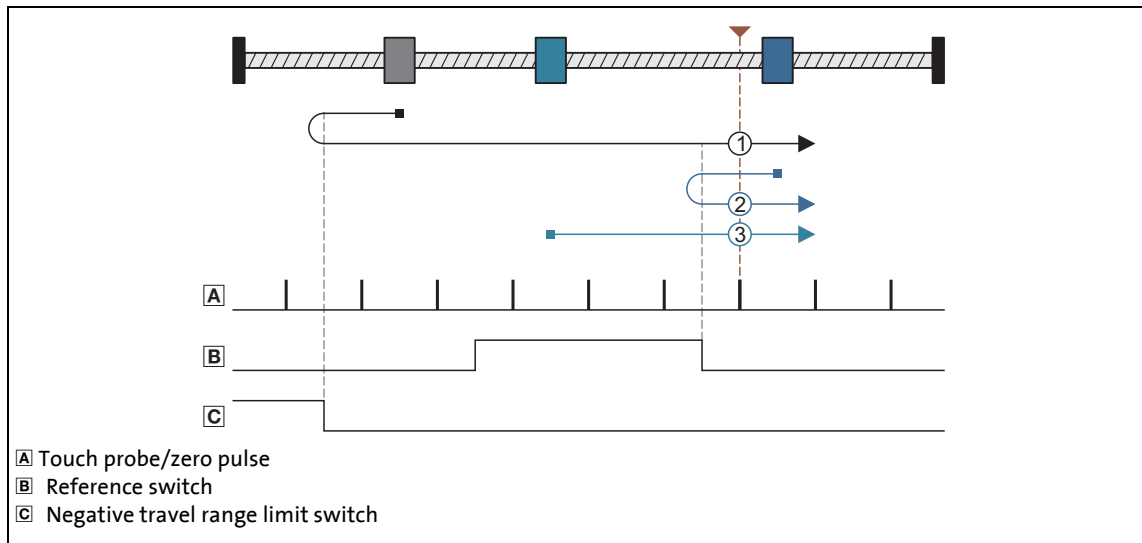

#### Procedures:

- Case 1: Axis does not activate the reference switch while moving towards the limit switch:
1. Movement in negative direction with profile data set 1.
  2. Reversing to negative travel range limit switch.
  3. Positive edge of the reference switch activates profile data set 2.
  4. Negative edge of the reference switch activates touch probe recognition.
  5. The following positive edge of the encoder zero pulse/touch probe sensor sets the reference.
  6. Absolute positioning to target position ([C02643](#)) with profile data set 2 (if [C02641](#) = "0").
- Case 2: Axis first activates the reference switch while moving towards the limit switch:
1. Movement in negative direction with profile data set 1.
  2. Reversing with positive edge of the reference switch and change-over to profile data set 2.
  3. Negative edge of the reference switch activates touch probe recognition.
  4. The following positive edge of the encoder zero pulse/touch probe sensor sets the reference.
  5. Absolute positioning to target position ([C02643](#)) with profile data set 2 (if [C02641](#) = "0").
- Case 3: Axis is already positioned on reference switch:
1. Movement in positive direction with profile data set 2.
  2. Negative edge of the reference switch activates touch probe recognition.
  3. The following positive edge of the encoder zero pulse/touch probe sensor sets the reference.
  4. Absolute positioning to target position ([C02643](#)) with profile data set 2 (if [C02641](#) = "0").

### Mode 1012: DS402 homing method 12

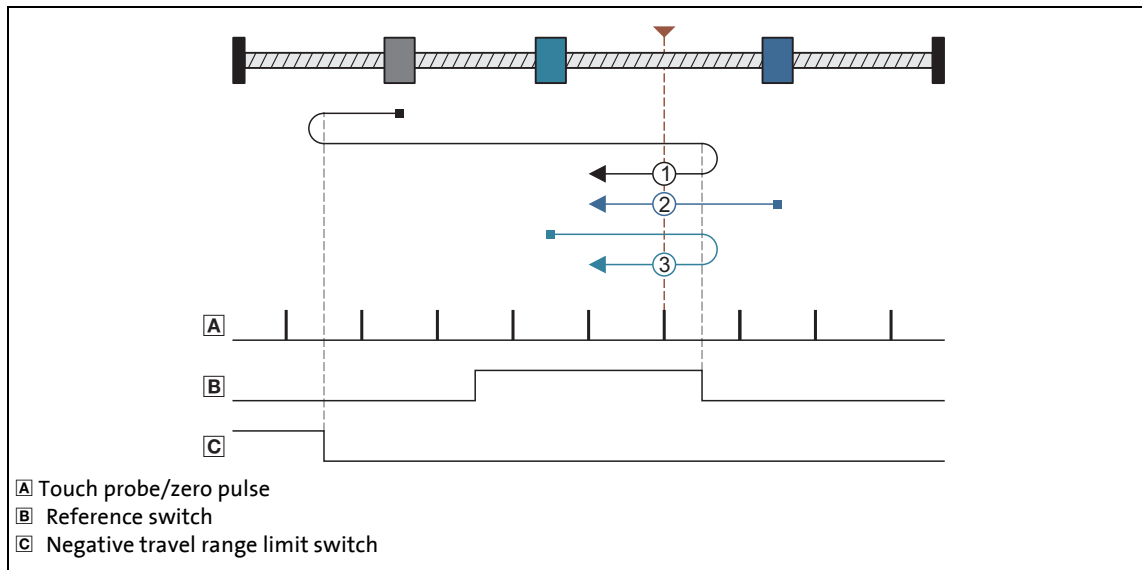

#### Procedures:

- Case 1: Axis does not activate the reference switch while moving towards the limit switch:
1. Movement in negative direction with profile data set 1.
  2. Reversing to negative travel range limit switch.
  3. Positive edge of the reference switch activates profile data set 2.
  4. Reversing with negative edge of the reference switch.
  5. Positive edge of the reference switch activates touch probe detection.
  6. The following positive edge of the encoder zero pulse/touch probe sensor sets the reference.
  7. Absolute positioning to target position ([C02643](#)) with profile data set 2 (if [C02641](#) = "0").
- Case 2: Axis first activates the reference switch while moving towards the limit switch:
1. Movement in negative direction with profile data set 1.
  2. Positive edge of the reference switch activates touch probe detection and change to profile data set 2.
  3. The following positive edge of the encoder zero pulse/touch probe sensor sets the reference.
  4. Absolute positioning to target position ([C02643](#)) with profile data set 2 (if [C02641](#) = "0").
- Case 3: Axis is already positioned on reference switch:
1. Movement in positive direction with profile data set 2.
  2. Reversing with negative edge of the reference switch.
  3. Positive edge of the reference switch activates touch probe detection.
  4. The following positive edge of the encoder zero pulse/touch probe sensor sets the reference.
  5. Absolute positioning to target position ([C02643](#)) with profile data set 2 (if [C02641](#) = "0").

### Mode 1013: DS402 homing method 13

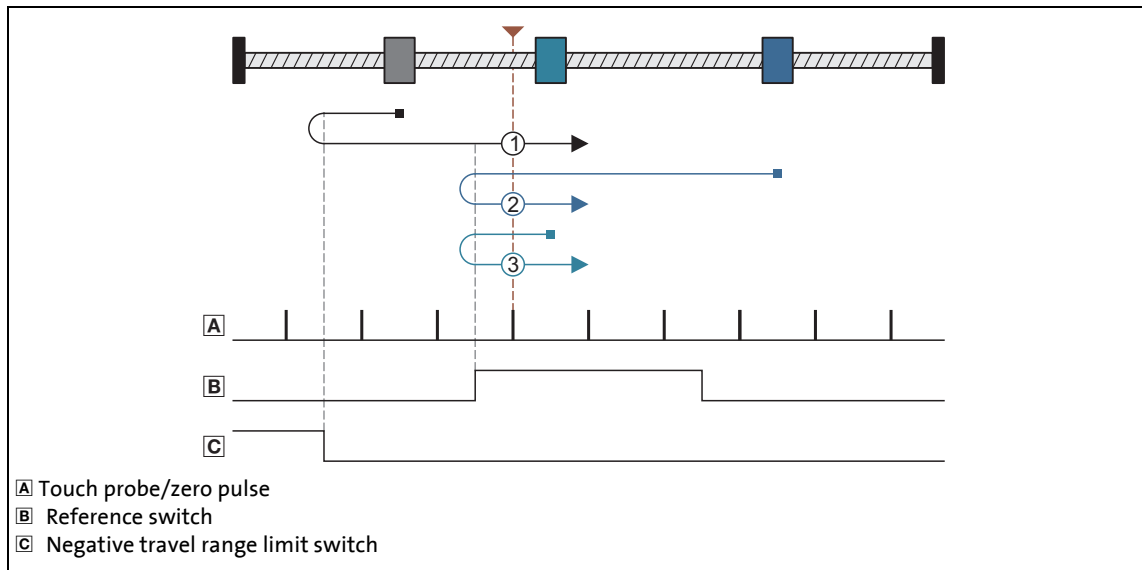

#### Procedures:

- Case 1: Axis does not activate the reference switch while moving towards the limit switch:
1. Movement in negative direction with profile data set 1.
  2. Reversing to negative travel range limit switch.
  3. Positive edge of the reference switch activates touch probe detection and change to profile data set 2.
  4. The following positive edge of the encoder zero pulse/touch probe sensor sets the reference.
  5. Absolute positioning to target position ([C02643](#)) with profile data set 2 (if [C02641](#) = "0").
- Case 2: Axis first activates the reference switch while moving towards the limit switch:
1. Movement in negative direction with profile data set 1.
  2. Positive edge of the reference switch activates profile data set 2.
  3. Reversing with negative edge of the reference switch.
  4. Positive edge of the reference switch activates touch probe detection.
  5. The following positive edge of the encoder zero pulse/touch probe sensor sets the reference.
  6. Absolute positioning to target position ([C02643](#)) with profile data set 2 (if [C02641](#) = "0").
- Case 3: Axis is already positioned on reference switch:
1. Movement in negative direction with profile data set 2.
  2. Reversing with negative edge of the reference switch.
  3. Positive edge of the reference switch activates touch probe detection.
  4. The following positive edge of the encoder zero pulse/touch probe sensor sets the reference.
  5. Absolute positioning to target position ([C02643](#)) with profile data set 2 (if [C02641](#) = "0").

## Mode 1014: DS402 homing method 14

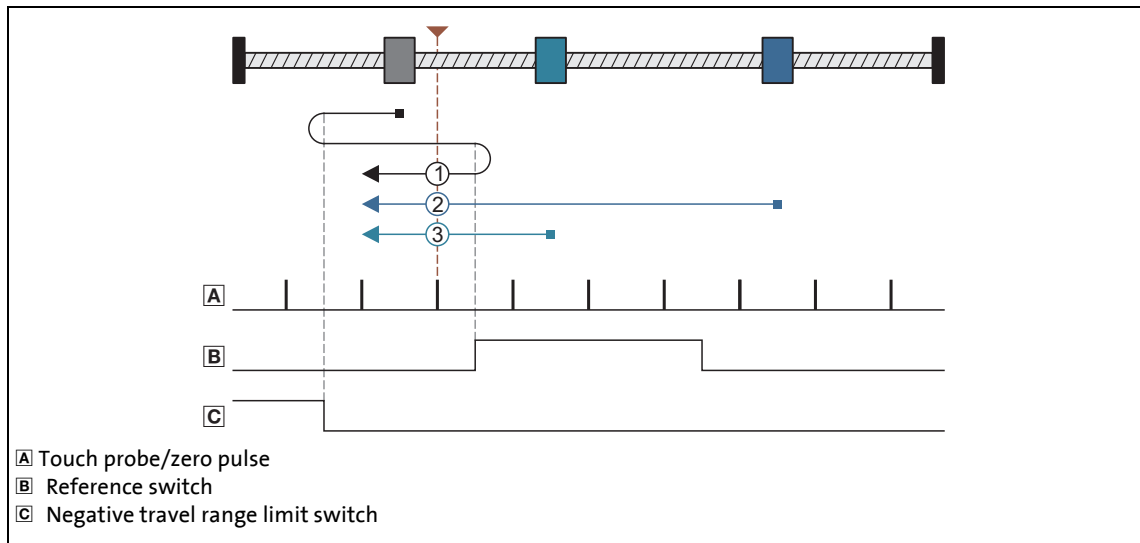
**Procedures:**

Case 1:

Axis does not activate the reference switch while moving towards the limit switch:

1. Movement in negative direction with profile data set 1.
2. Reversing to negative travel range limit switch.
3. Reversing with positive edge of the reference switch and change-over to profile data set 2.
4. Negative edge of the reference switch activates touch probe recognition.
5. The following positive edge of the encoder zero pulse/touch probe sensor sets the reference.
6. Absolute positioning to target position ([C02643](#)) with profile data set 2 (if [C02641](#) = "0").

Case 2:

Axis first activates the reference switch while moving towards the limit switch:

1. Movement in negative direction with profile data set 1.
2. Positive edge of the reference switch activates profile data set 2.
3. Negative edge of the reference switch activates touch probe recognition.
4. The following positive edge of the encoder zero pulse/touch probe sensor sets the reference.
5. Absolute positioning to target position ([C02643](#)) with profile data set 2 (if [C02641](#) = "0").

Case 3:

Axis is already positioned on reference switch:

1. Movement in negative direction with profile data set 2.
2. Negative edge of the reference switch activates touch probe recognition.
3. The following positive edge of the encoder zero pulse/touch probe sensor sets the reference.
4. Absolute positioning to target position ([C02643](#)) with profile data set 2 (if [C02641](#) = "0").

# 11 Basic drive functions

## 11.6 Homing

### Mode 1015: DS402 homing method 15

Reserved: no homing is executed.

### Mode 1016: DS402 homing method 16

Reserved: no homing is executed.

### Mode 1017: DS402 homing method 17

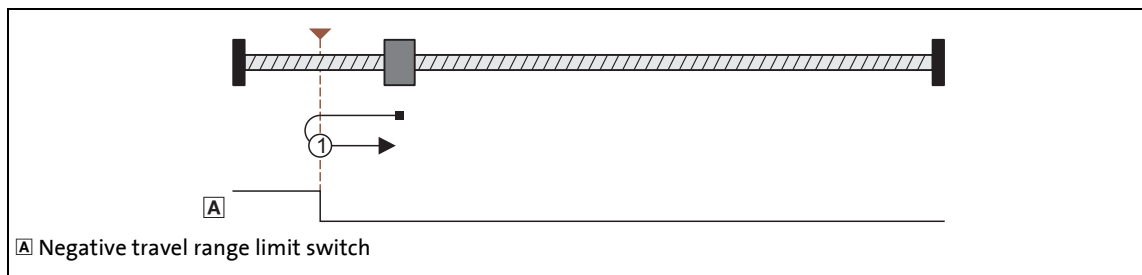

#### Procedure:

1. Movement in negative direction with profile data set 1.
2. Reversing to negative travel range limit switch and change-over to profile data set 2.
3. The following negative edge of the travel range limit switch sets the reference.
4. Absolute positioning to target position ([C02643](#)) with profile data set 2 (if [C02641](#) = "0").

### Mode 1018: DS402 homing method 18

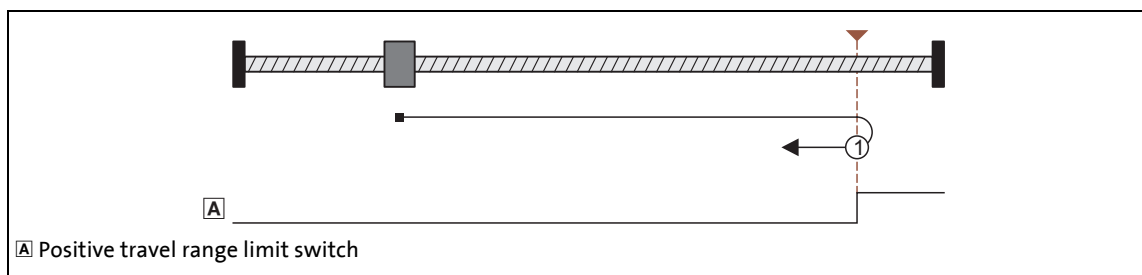

#### Procedure:

1. Movement in positive direction with profile data set 1.
2. Reversing to positive travel range limit switch and change-over to profile data set 2.
3. The following negative edge of the travel range limit switch sets the reference.
4. Absolute positioning to target position ([C02643](#)) with profile data set 2 (if [C02641](#) = "0").

# 11 Basic drive functions

## 11.6 Homing

### Mode 1019: DS402 homing method 19

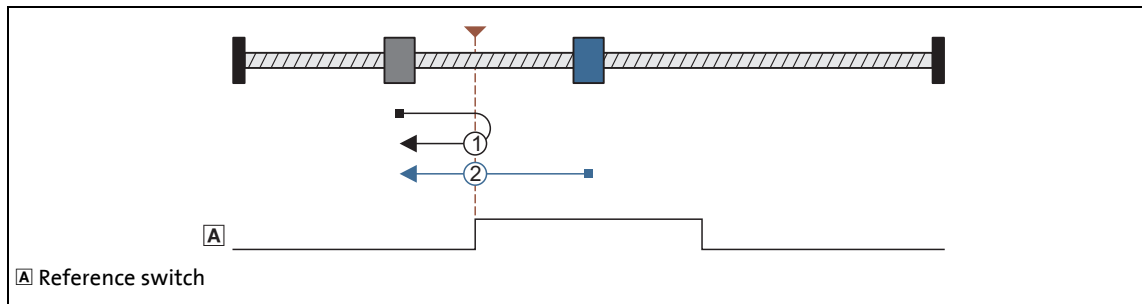

#### Procedures:

Case 1: Axis has not activated reference switch yet:

1. Movement in positive direction with profile data set 1.
2. Reversing with positive edge of the reference switch and change-over to profile data set 2.
3. The following negative edge of the reference switch sets the reference.
4. Absolute positioning to target position ([C02643](#)) with profile data set 2 (if [C02641](#) = "0").

Case 2: Axis is already positioned on reference switch:

1. Movement in negative direction with profile data set 2.
2. The following negative edge of the reference switch sets the reference.
3. Absolute positioning to target position ([C02643](#)) with profile data set 2 (if [C02641](#) = "0").

### Mode 1020: DS402 homing method 20

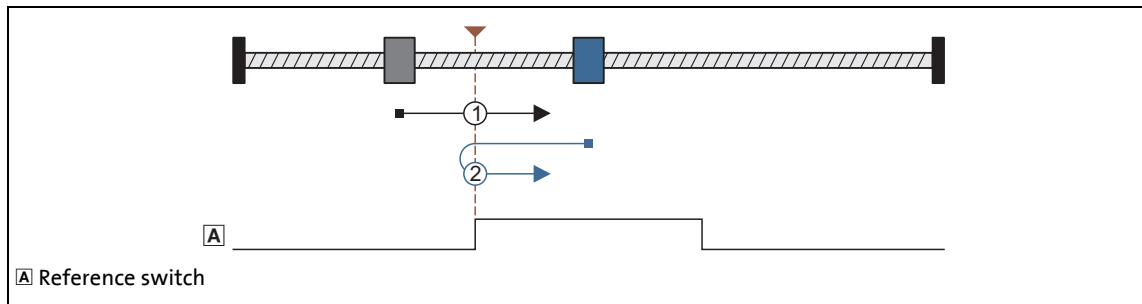

#### Procedures:

Case 1: Axis has not activated reference switch yet:

1. Movement in positive direction with profile data set 1.
2. The following positive edge of the reference switch sets the reference.
3. Absolute positioning to target position ([C02643](#)) with profile data set 2 (if [C02641](#) = "0").

Case 2: Axis is already positioned on reference switch:

1. Movement in negative direction with profile data set 2.
2. Reversing with negative edge of the reference switch.
3. The following positive edge of the reference switch sets the reference.
4. Absolute positioning to target position ([C02643](#)) with profile data set 2 (if [C02641](#) = "0").



### Mode 1021: DS402 homing method 21

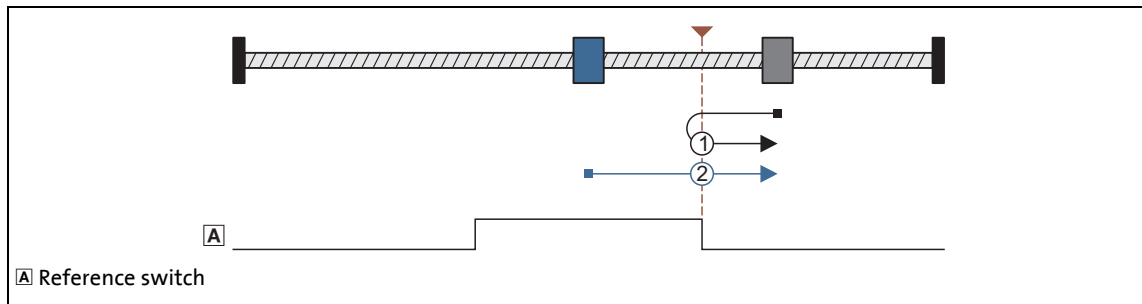

#### Procedures:

Case 1: Axis has not activated reference switch yet:

1. Movement in negative direction with profile data set 1.
2. Reversing with positive edge of the reference switch and change-over to profile data set 2.
3. The following negative edge of the reference switch sets the reference.
4. Absolute positioning to target position ([C02643](#)) with profile data set 2 (if [C02641](#) = "0").

Case 2: Axis is already positioned on reference switch:

1. Movement in positive direction with profile data set 2.
2. The following negative edge of the reference switch sets the reference.
3. Absolute positioning to target position ([C02643](#)) with profile data set 2 (if [C02641](#) = "0").

### Mode 1022: DS402 homing method 22

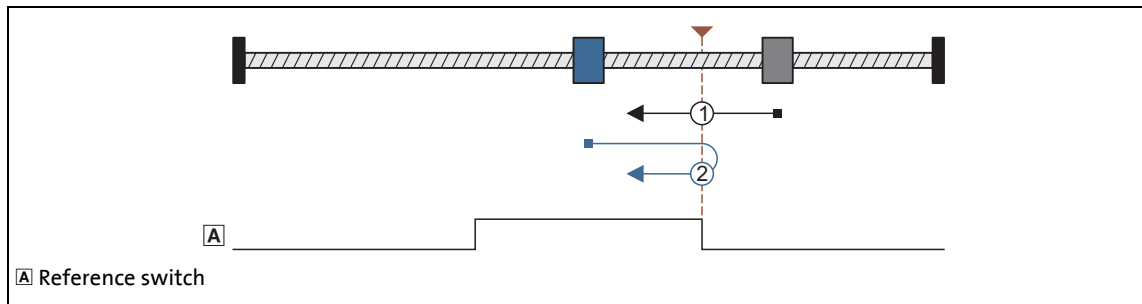

#### Procedures:

Case 1: Axis has not activated reference switch yet:

1. Movement in negative direction with profile data set 1.
2. The following positive edge of the reference switch sets the reference.
3. Absolute positioning to target position ([C02643](#)) with profile data set 2 (if [C02641](#) = "0").

Case 2: Axis is already positioned on reference switch:

1. Movement in positive direction with profile data set 2.
2. Reversing with negative edge of the reference switch.
3. The following positive edge of the reference switch sets the reference.
4. Absolute positioning to target position ([C02643](#)) with profile data set 2 (if [C02641](#) = "0").

### Mode 1023: DS402 homing method 23

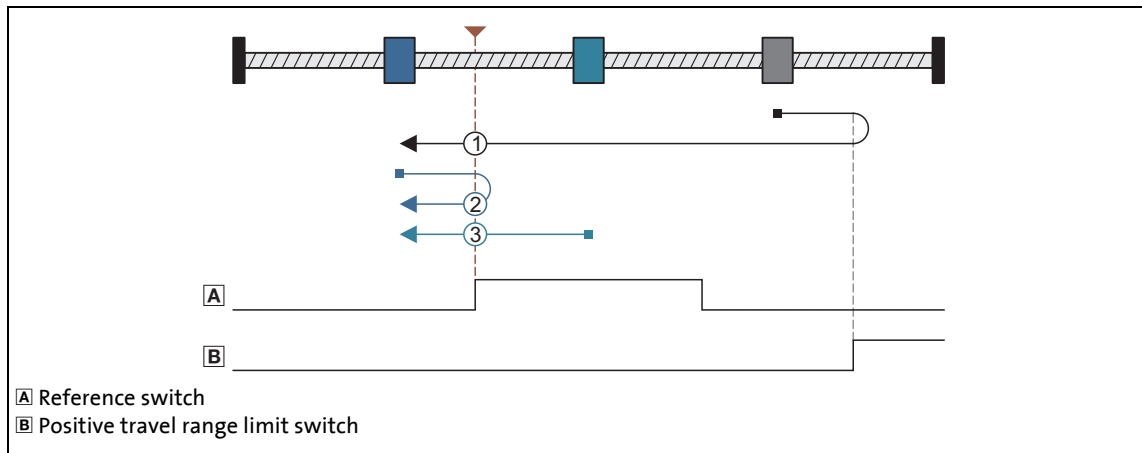

#### Procedures:

- Case 1: Axis does not activate the reference switch while moving towards the limit switch:
1. Movement in positive direction with profile data set 1.
  2. Reversing to positive travel range limit switch.
  3. Positive edge of the reference switch activates profile data set 2.
  4. The following negative edge of the reference switch sets the reference.
  5. Absolute positioning to target position ([C02643](#)) with profile data set 2 (if [C02641](#) = "0").
- Case 2: Axis first activates the reference switch while moving towards the limit switch:
1. Movement in positive direction with profile data set 1.
  2. Reversing with positive edge of the reference switch and change-over to profile data set 2.
  3. The following negative edge of the reference switch sets the reference.
  4. Absolute positioning to target position ([C02643](#)) with profile data set 2 (if [C02641](#) = "0").
- Case 3: Axis is already positioned on reference switch:
1. Movement in negative direction with profile data set 2.
  2. The following negative edge of the reference switch sets the reference.
  3. Absolute positioning to target position ([C02643](#)) with profile data set 2 (if [C02641](#) = "0").

### Mode 1024: DS402 homing method 24

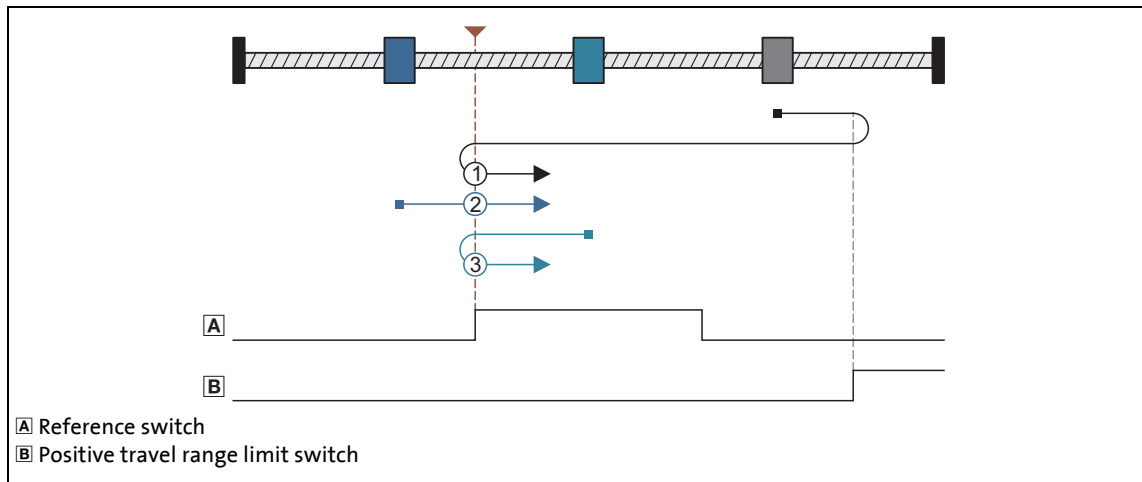

#### Procedures:

- Case 1: Axis does not activate the reference switch while moving towards the limit switch:
1. Movement in positive direction with profile data set 1.
  2. Reversing to positive travel range limit switch.
  3. Positive edge of the reference switch activates profile data set 2.
  4. Reversing with negative edge of the reference switch.
  5. The following positive edge of the reference switch sets the reference.
  6. Absolute positioning to target position ([C02643](#)) with profile data set 2 (if [C02641](#) = "0").
- Case 2: Axis first activates the reference switch while moving towards the limit switch:
1. Movement in positive direction with profile data set 1.
  2. The following positive edge of the reference switch sets the reference.
  3. Absolute positioning to target position ([C02643](#)) with profile data set 2 (if [C02641](#) = "0").
- Case 3: Axis is already positioned on reference switch:
1. Movement in negative direction with profile data set 2.
  2. Reversing with negative edge of the reference switch.
  3. The following positive edge of the reference switch sets the reference.
  4. Absolute positioning to target position ([C02643](#)) with profile data set 2 (if [C02641](#) = "0").

### Mode 1025: DS402 homing method 25

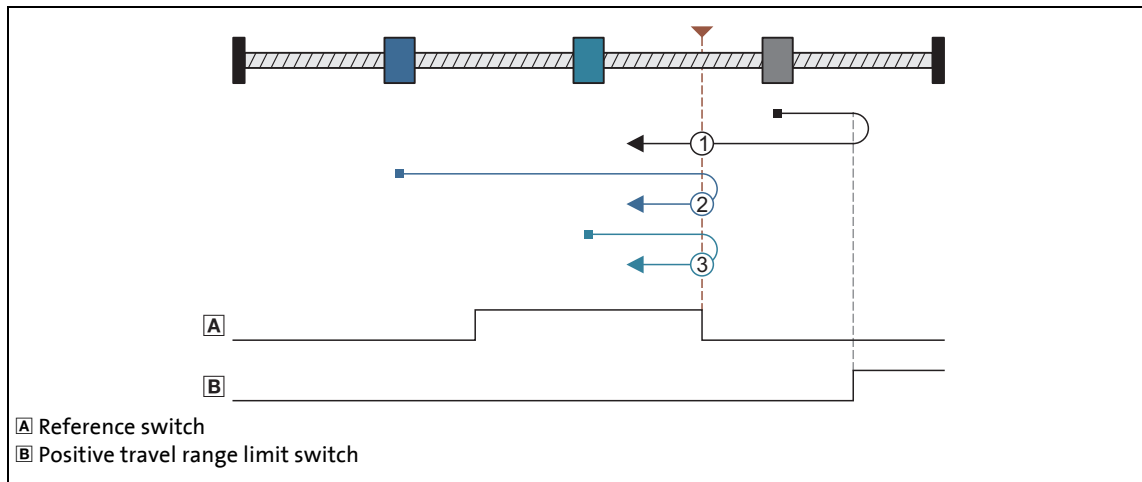

#### Procedures:

- Case 1: Axis does not activate the reference switch while moving towards the limit switch:
1. Movement in positive direction with profile data set 1.
  2. Reversing to positive travel range limit switch.
  3. The following positive edge of the reference switch sets the reference.
  4. Absolute positioning to target position ([C02643](#)) with profile data set 2 (if [C02641](#) = "0").
- Case 2: Axis first activates the reference switch while moving towards the limit switch:
1. Movement in positive direction with profile data set 1.
  2. The following positive edge of the reference switch sets the reference.
  3. Absolute positioning to target position ([C02643](#)) with profile data set 2 (if [C02641](#) = "0").
- Case 3: Axis already stands on the reference switch:
1. Movement in positive direction with profile data set 2.
  2. Reversing with negative edge of the reference switch.
  3. The following positive edge of the reference switch sets the reference.
  4. Absolute positioning to target position ([C02643](#)) with profile data set 2 (if [C02641](#) = "0").

### Mode 1026: DS402 homing method 26

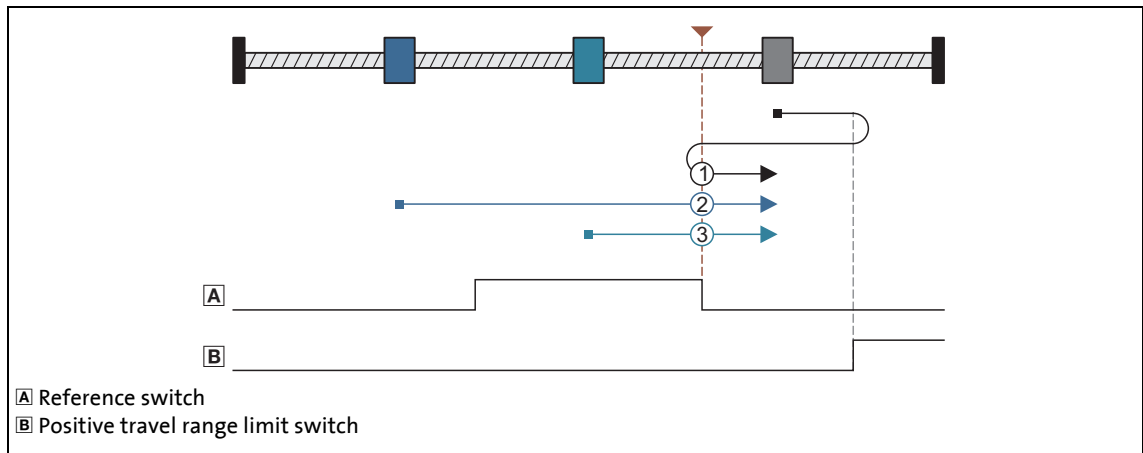

#### Procedures:

- Case 1: Axis does not activate the reference switch while moving towards the limit switch:
1. Movement in positive direction with profile data set 1.
  2. Reversing to positive travel range limit switch.
  3. Reversing with positive edge of the reference switch and change-over to profile data set 2.
  4. The following negative edge of the reference switch sets the reference.
  5. Absolute positioning to target position ([C02643](#)) with profile data set 2 (if [C02641](#) = "0").
- Case 2: Axis first activates the reference switch while moving towards the limit switch:
1. Movement in positive direction with profile data set 1.
  2. Positive edge of the reference switch activates profile data set 2.
  3. The following negative edge of the reference switch sets the reference.
  4. Absolute positioning to target position ([C02643](#)) with profile data set 2 (if [C02641](#) = "0").
- Case 3: Axis is already positioned on reference switch:
1. Movement in positive direction with profile data set 2.
  2. The following negative edge of the reference switch sets the reference.
  3. Absolute positioning to target position ([C02643](#)) with profile data set 2 (if [C02641](#) = "0").

### Mode 1027: DS402 homing method 27

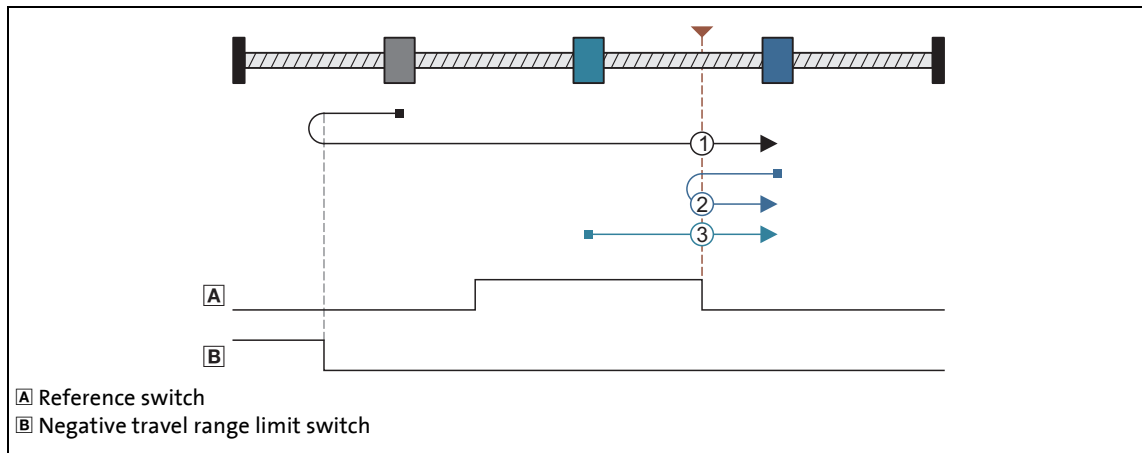

#### Procedures:

- Case 1: Axis does not activate the reference switch while moving towards the limit switch:
1. Movement in negative direction with profile data set 1.
  2. Reversing to negative travel range limit switch.
  3. Positive edge of the reference switch activates profile data set 2.
  4. The following negative edge of the reference switch sets the reference.
  5. Absolute positioning to target position ([C02643](#)) with profile data set 2 (if [C02641](#) = "0").
- Case 2: Axis first activates the reference switch while moving towards the limit switch:
1. Movement in negative direction with profile data set 1.
  2. Reversing with positive edge of the reference switch and change-over to profile data set 2.
  3. The following negative edge of the reference switch sets the reference.
  4. Absolute positioning to target position ([C02643](#)) with profile data set 2 (if [C02641](#) = "0").
- Case 3: Axis is already positioned on reference switch:
1. Movement in positive direction with profile data set 2.
  2. The following negative edge of the reference switch sets the reference.
  3. Absolute positioning to target position ([C02643](#)) with profile data set 2 (if [C02641](#) = "0").

### Mode 1028: DS402 homing method 28

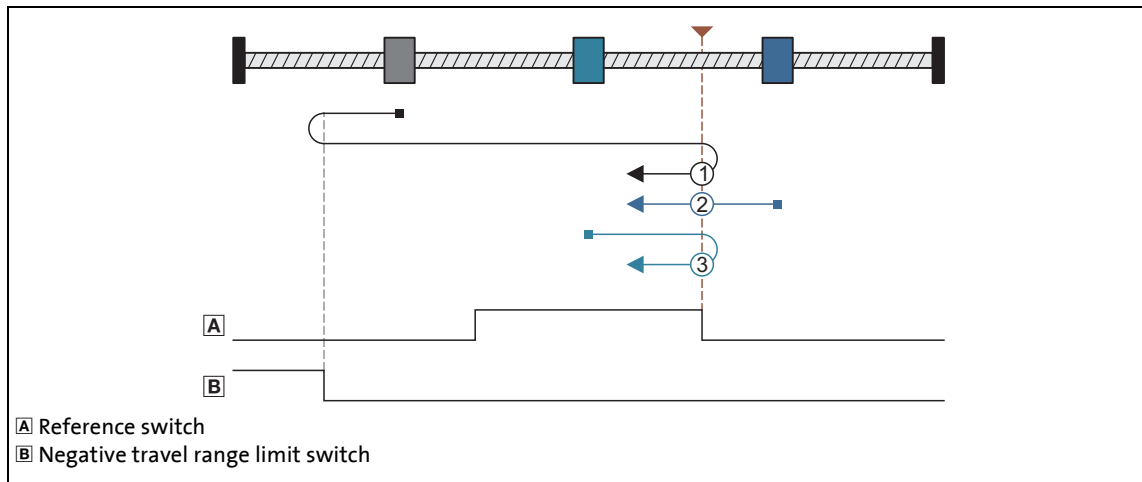

#### Procedures:

- Case 1: Axis does not activate the reference switch while moving towards the limit switch:
1. Movement in negative direction with profile data set 1.
  2. Reversing to negative travel range limit switch.
  3. Positive edge of the reference switch activates profile data set 2.
  4. Reversing with negative edge of the reference switch.
  5. The following positive edge of the reference switch sets the reference.
  6. Absolute positioning to target position ([C02643](#)) with profile data set 2 (if [C02641](#) = "0").
- Case 2: Axis first activates the reference switch while moving towards the limit switch:
1. Movement in negative direction with profile data set 1.
  2. The following positive edge of the reference switch sets the reference.
  3. Absolute positioning to target position ([C02643](#)) with profile data set 2 (if [C02641](#) = "0").
- Case 3: Axis is already positioned on reference switch:
1. Movement in positive direction with profile data set 2.
  2. Reversing with negative edge of the reference switch.
  3. The following positive edge of the reference switch sets the reference.
  4. Absolute positioning to target position ([C02643](#)) with profile data set 2 (if [C02641](#) = "0").



### Mode 1029: DS402 homing method 29

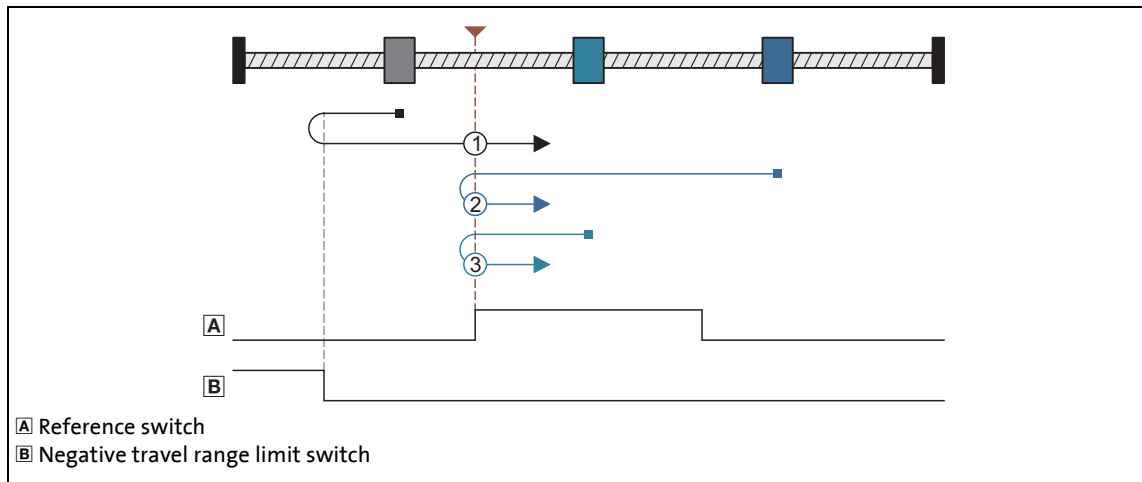

#### Procedures:

- Case 1: Axis does not activate the reference switch while moving towards the limit switch:
1. Movement in negative direction with profile data set 1.
  2. Reversing to negative travel range limit switch.
  3. The following positive edge of the reference switch sets the reference.
  4. Absolute positioning to target position ([C02643](#)) with profile data set 2 (if [C02641](#) = "0").
- Case 2: Axis first activates the reference switch while moving towards the limit switch:
1. Movement in negative direction with profile data set 1.
  2. Positive edge of the reference switch activates profile data set 2.
  3. Reversing with negative edge of the reference switch.
  4. The following positive edge of the reference switch sets the reference.
  5. Absolute positioning to target position ([C02643](#)) with profile data set 2 (if [C02641](#) = "0").
- Case 3: Axis is already positioned on reference switch:
1. Movement in negative direction with profile data set 2.
  2. Reversing with negative edge of the reference switch.
  3. The following positive edge of the reference switch sets the reference.
  4. Absolute positioning to target position ([C02643](#)) with profile data set 2 (if [C02641](#) = "0").

### Mode 1030: DS402 homing method 30

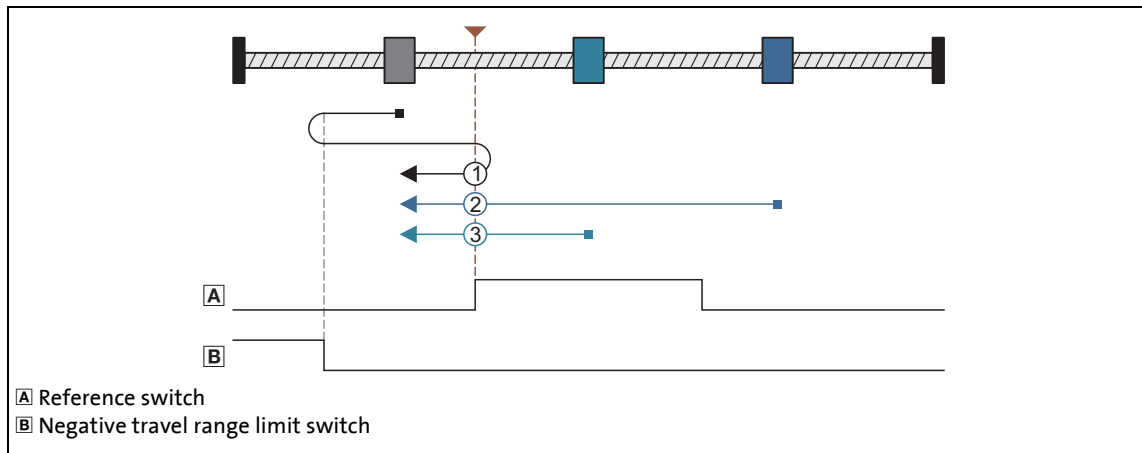

#### Procedures:

- Case 1: Axis does not activate the reference switch while moving towards the limit switch:
1. Movement in negative direction with profile data set 1.
  2. Reversing to negative travel range limit switch.
  3. Reversing with positive edge of the reference switch and change-over to profile data set 2.
  4. The following negative edge of the reference switch sets the reference.
  5. Absolute positioning to target position ([C02643](#)) with profile data set 2 (if [C02641](#) = "0").
- Case 2: Axis first activates the reference switch while moving towards the limit switch:
1. Movement in negative direction with profile data set 1.
  2. Positive edge of the reference switch activates profile data set 2.
  3. The following negative edge of the reference switch sets the reference.
  4. Absolute positioning to target position ([C02643](#)) with profile data set 2 (if [C02641](#) = "0").
- Case 3: Axis is already positioned on reference switch:
1. Movement in negative direction with profile data set 2.
  2. The following negative edge of the reference switch sets the reference.
  3. Absolute positioning to target position ([C02643](#)) with profile data set 2 (if [C02641](#) = "0").

# 11 Basic drive functions

## 11.6 Homing

---

### Mode 1031: DS402 homing method 31

Reserved: no homing is executed.

### Mode 1032: DS402 homing method 32

Reserved: no homing is executed.

### Mode 1033: DS402 homing method 33

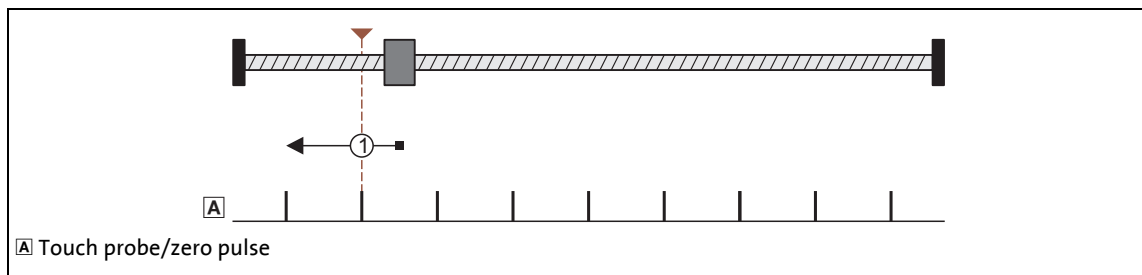

#### Procedure:

1. Movement in negative direction with profile data set 1 and activation of the touch probe recognition.
2. The following positive edge of the touch probe sensor sets the reference.
3. Absolute positioning to target position ([C02643](#)) with profile data set 2 (if [C02641](#) = "0").

### Mode 1034: DS402 homing method 34

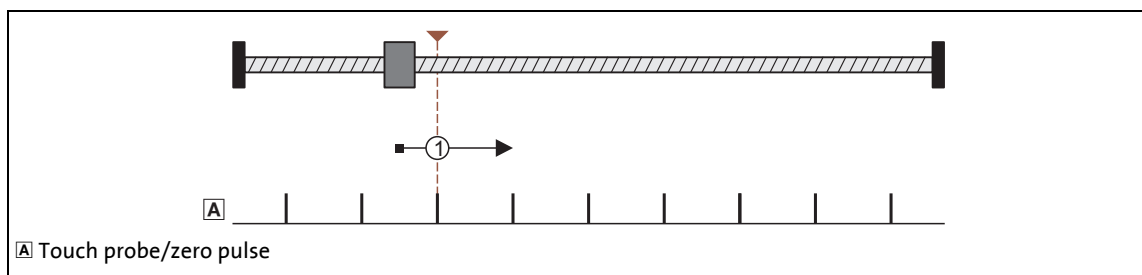

#### Procedure:

1. Movement in positive direction with profile data set 1 and activation of the touch probe recognition.
2. The following positive edge of the touch probe sensor sets the reference.
3. Absolute positioning to target position ([C02643](#)) with profile data set 2 (if [C02641](#) = "0").

### Mode 1035: DS402 homing method 35

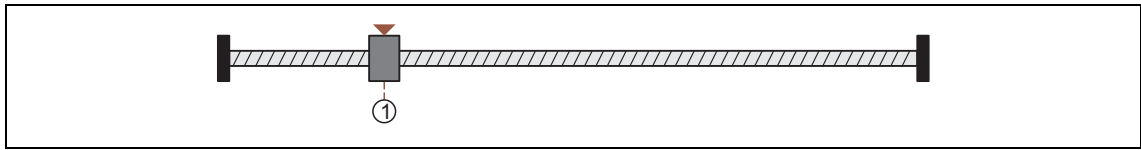

Direct reference setting.

### 11.6.5 Execute homing

#### Prerequisites

- The controller is in the "Operation" device state.
- The basic function "Homing" is part of the active application.
- No other basic function is active.

#### Activation

To request the control via the basic function, the *HM\_bEnable* enable input in the application must be set to TRUE.

- If no other basic function is active, a change-over to the "Homing active" function state is effected and homing can be carried out via the control inputs.
- A successful change to the "Homing active" function state is displayed by a TRUE signal at the *HM\_bEnabled* status output.

#### Deactivation

When the *HM\_bEnable* enable input is reset to FALSE, an active homing is stopped, i.e. the control inputs for homing are inhibited and the drive is braked to standstill within the deceleration time for stop.

- The status output *HM\_bEnabled* is reset to FALSE and a change-over from the active "Homing active" function state via the "Drive is stopped" function state back to the basic state "Drive at standstill" is carried out.

### 11.6.5.1 Starting reference search/setting the reference directly

By setting the *HM\_bActivateHoming* control input to TRUE, the reference search in the selected homing mode is started.

- During reference search, the *HM\_bActive* status output is set to TRUE.
- By setting the status output *HM\_bHomePosAvailable* to TRUE, it is already signalled during the reference search that the home position has been found. Depending on the homing mode selected, the drive traverses further on to the target position set in [C02643](#).
- When the reference search is completed, the *HM\_bActive* status output is reset to FALSE and the *HM\_bDone* status output is set to TRUE.



#### Note!

In the homing mode "100: Set reference directly" no reference search is started, but the home position set in [C02642](#) is directly accepted.

### 11.6.5.2 Loading home position via input

By setting the control input *HM\_bLoadHomePos* to TRUE, the "Tool position" that is pending at input *HM\_dnHomePos\_p* is manually accepted as home position during the drive is at standstill. This is also possible if the controller is inhibited.

- The *HM\_bDone* status output is set to TRUE for one cycle.
- The *HM\_bHomePosAvailable* status output is set to TRUE.



#### Note!

**For the encoderless motor control types (from software version V3.0) the following applies:**

If V/f control or sensorless vector control has been selected, this function is only effective if the position controller has also been selected for the position control ([C02570](#) = "2: position controller active").

**For the encoderless motor control types (from software version V5.0) the following applies:**

If the V/f control or sensorless vector control is selected, this function can be activated irrespective of the use of the position controller.

### 11.6.5.3 Reset home position

By setting the control input *HM\_bResetHomePos* to TRUE, the "Home position known" status can be reset.

- The status outputs *HM\_bDone* and *HM\_bHomePosAvailable* are reset to FALSE.



#### Note!

**For the encoderless motor control types (from software version V3.0) the following applies:**

If V/f control or sensorless vector control has been selected, this function is only effective if the position controller has also been selected for the position control (*C02570* = "2: position controller active").

**For the encoderless motor control types (from software version V5.0) the following applies:**

If the V/f control or sensorless vector control is selected, this function can be activated irrespective of the use of the position controller.

---

## 11.7 Positioning

The basic function "Positioning" provides the functions for executing the (travel) profiles and supports an "override" of speed and acceleration.

- A profile describes a motion request which can be implemented by this basic function into a rotary motion.
- A profile is described via the following profile parameters: Mode (type of positioning), position, speed, acceleration, deceleration, S-ramp time, final speed, standard sequence profile, TP sequence profile, TP window starting and end position and touch probe signal source(s).



### Note!

For positioning, setpoint speeds greater than 30000 rpm are not possible. The speeds defined for these basic function are internally limited to 30000 rpm.

If the basic function is activated for a speed greater than 30000 rpm (e. g. if the basic function "Speed follower" is replaced), the internal limitation of the speed setpoint causes a speed step.

When the basic function is activated, a start acceleration is considered. ▶ [Start acceleration/acceleration reduction when the basic function changes](#) (□ 385)

**For the encoderless motor control types (from software version V3.0) the following applies:**

If no position controller has been selected for the position control in case of V/f control or sensorless vector control ([C02570](#) = "1: Phase controller is active"), positioning is only executed via the speed profile resulting from the profile parameters. Because of this, the target positions set will only "roughly" be reached.

### 11.7.1 Internal interfaces | "LS\_Positioner" system block

The **LS\_Positioner** system block provides the internal interfaces for the basic function "Positioning" in the function block editor.

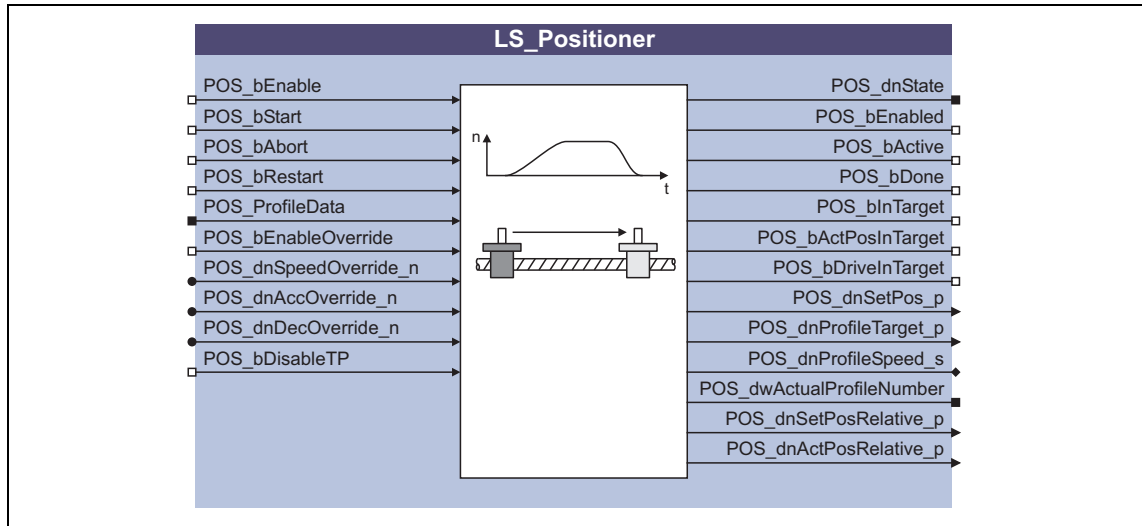

#### Note!

Ensure that the system block is called in a cyclic application task.

Basically, projects which only contain an unsolicited task and no cyclic task are not permissible!

#### Inputs

Identifier <small>DIS code   data type</small>	Information/possible settings
POS_bEnable <a href="#">C02679/1</a>   BOOL	Request control of basic function
	<p>TRUE: If no other basic function is active, a change-over to the "Positioning active" function state is effected and positioning can be carried out via the control inputs.</p> <p>TRUE↔FALSE: Active positioning is stopped, i. e. a change-over from the active "Positioning active" function state via the "Drive is stopped" function state back to the basic state "Drive at standstill" is carried out.</p>
POS_bStart <a href="#">C02679/2</a>   BOOL	Start positioning
	<p>FALSE↗TRUE: The profile <i>POS_ProfileData</i> is executed.</p> <p>FALSE↗TRUE (once again): "Restart"</p> <ul style="list-style-type: none"> <li>During an active positioning process, another profile can be specified via the input <i>POS_ProfileData</i> which is executed after restart.</li> <li>Distances of a relative positioning that have already been covered are <u>not</u> taken into consideration.</li> </ul>



Identifier DIS code   data type	Information/possible settings
POS_bAbort <a href="#">C02679/3</a>   BOOL	Abort or interrupt positioning
	FALSE↗TRUE The current profile is not completed but braked to standstill with the deceleration defined in the profile data.
	TRUE A restart via <i>POS_bStart</i> or the continuation of an interrupted positioning via <i>POS_bRestart</i> is inhibited.
	FALSE A restart via <i>POS_bStart</i> or the continuation of an interrupted positioning via <i>POS_bRestart</i> is possible again. • If the restart signal <i>POS_bRestart</i> is already effected during the deceleration phase, positioning is continued immediately.
POS_bRestart <a href="#">C02679/4</a>   BOOL	Continue interrupted positioning • Only possible if <i>POS_bAbort</i> has been reset from TRUE to FALSE.
	TRUE The positioning interrupted before via <i>POS_bAbort</i> is completed. • Distances of a relative positioning already covered are taken into account.
	FALSE↗TRUE (once again) "Restart" • During an active positioning process, another profile can be specified via the input <i>POS_ProfileData</i> which is executed after restart. • Distances of a relative positioning already covered are taken into account.
POS_ProfileData	Pointer to the profile to be executed in internal units (increments) • A profile linkage results from the fact that a pointer to the sequence profile is contained within the profile.
POS_bEnableOverride <a href="#">C02679/5</a>   BOOL	Activate override
	TRUE Override of the speed, acceleration, and deceleration is active. • If the <i>POS_dnDecOverride_n</i> input is triggered with a very low value after the override function is activated, the drive decelerates correspondingly slow. The target position may be overtravelled.
POS_dnSpeedOverride_n <a href="#">C02677/1</a>   DINT	Value for speed override • Percentage multiplier for the current profile parameter "Speed". • Changes are accepted in each cycle. • $2^{30} \equiv 100\%$ of the speed defined in the profile. • For values $\leq 1\%$ the status bit 18 is set. • Values $\leq 0\%$ are set to $0\%$ internally and lead to the standstill of the drive.
POS_dnAccOverride_n <a href="#">C02677/2</a>   DINT	Value for acceleration override • Percentage multiplier for the current profile parameter "Acceleration". • Changes are accepted in each cycle. • $2^{30} \equiv 100\%$ of the acceleration defined in the profile. • For values $\leq 1\%$ the status bit 19 is set. • Values $\leq 0\%$ are internally set to $0\%$ ("no acceleration").
POS_dnDecOverride_n <a href="#">C02677/3</a>   DINT From V5.0	Value for deceleration override • Percentage multiplier for the current profile parameter "Deceleration". • Changes are accepted in each cycle. • $2^{30} \equiv 100\%$ of the acceleration defined in the profile. • For values $\leq 1\%$ the status bit 19 is set. • Values $\leq 0\%$ are internally set to $0\%$ ("no deceleration").
POS_bDisableTP <a href="#">C02679/6</a>   BOOL	Deactivating touch probe positioning
	TRUE Detected touch probes are ignored. There is no automatic change-over to the TP sequence profile defined in the profile data.

## Outputs

Identifier DIS code   data type	Value/meaning			
POS_dnState <a href="#">C02675</a>   DINT	Status (bit coded) <ul style="list-style-type: none"> <li>When the basic function is not enabled, all bits are set to "0".</li> <li>Bits which are not listed are not assigned with a status (always "0").</li> </ul>			
	Bit 1 Positioning active.			
	Bit 2 Positioning is completed (all profiles have been executed).			
	Bit 3 Acceleration/deceleration phase is active.			
	Bit 4 Actual position in the target <ul style="list-style-type: none"> <li>The actual position value of the drive has reached the target of the last profile to be traversed within the tolerance window set in <a href="#">C02670</a>.</li> </ul>			
	Bit 5 CCW rotation is active.			
	Bit 6 Set position reached (in case of sequence profiles the drive continues to travel).			
	Bit 10 Zero crossing in the positioning mode "modulo".			
	Bit 11 Positioning cannot be continued.			
	Bit 12 Drive in the target (actual position <u>and</u> set position in the target). <ul style="list-style-type: none"> <li>This status is available from software version V5.0.</li> </ul>			
	Bit 15 Fault in basic function active (group signal).			
	Bit 16 Positioning is aborted.			
	Bit 17 Reversing phase is active.			
	Bit 18 Speed override ≤1 %			
	Bit 19 Acceleration or deceleration override ≤ 1 %			
	Bit 20 Position is limited by basic function " <a href="#">Limiter</a> ".			
	Bit 21 Profile data are limited by basic function " <a href="#">Limiter</a> ".			
	Bit 22 Direction is inhibited by basic function " <a href="#">Limiter</a> ".			
	Bit 23 Abort by basic function " <a href="#">Limiter</a> ".			
	Bit 24 Home position is not known.			
	Bit 25 Stopping is active. <ul style="list-style-type: none"> <li>Basic function is enabled for the first time but no positioning has been requested / is active yet.</li> </ul>			
	Bit 26 Cycle is not known.			
	Bit 27 Invalid positioning mode.			
	Bit 28 Invalid change of the positioning mode.			
	Bit 29 Profile data are not plausible or incorrect.			
	Bit 30 Profile generation error.			
	POS_bEnabled <a href="#">C02679/7</a>   BOOL	Status signal "Basic function is enabled" <table border="1"> <tr> <td>TRUE</td> <td>Positioning via the control inputs is possible. <ul style="list-style-type: none"> <li>The <i>POS_bEnable</i> enable input is set to TRUE and the controller is in the "Positioning active" function state.</li> </ul> </td> </tr> </table>	TRUE	Positioning via the control inputs is possible. <ul style="list-style-type: none"> <li>The <i>POS_bEnable</i> enable input is set to TRUE and the controller is in the "Positioning active" function state.</li> </ul>
	TRUE	Positioning via the control inputs is possible. <ul style="list-style-type: none"> <li>The <i>POS_bEnable</i> enable input is set to TRUE and the controller is in the "Positioning active" function state.</li> </ul>		
	POS_bActive <a href="#">C02679/8</a>   BOOL	Status signal "Basic function is active" <table border="1"> <tr> <td>TRUE</td> <td>Positioning is active (the drive axis is moving).</td> </tr> </table>	TRUE	Positioning is active (the drive axis is moving).
	TRUE	Positioning is active (the drive axis is moving).		
	POS_bDone <a href="#">C02679/9</a>   BOOL	Status signal "Basic function is ready" <table border="1"> <tr> <td>TRUE</td> <td>Positioning is completed. <ul style="list-style-type: none"> <li>The profile is executed and no sequence profile is defined.</li> </ul> </td> </tr> </table>	TRUE	Positioning is completed. <ul style="list-style-type: none"> <li>The profile is executed and no sequence profile is defined.</li> </ul>
TRUE	Positioning is completed. <ul style="list-style-type: none"> <li>The profile is executed and no sequence profile is defined.</li> </ul>			

Identifier DIS code   data type	Value/meaning			
POS_bInTarget <a href="#">C02679/10</a>   BOOL	Status signal "Setpoint has reached target position"			
	<table border="1"> <tr> <td>FALSE</td> <td>Positioning is still active or has been aborted.</td> </tr> <tr> <td>TRUE</td> <td>The current position setpoint has reached the target position.</td> </tr> </table>	FALSE	Positioning is still active or has been aborted.	TRUE
FALSE	Positioning is still active or has been aborted.			
TRUE	The current position setpoint has reached the target position.			
POS_bActPosInTarget <a href="#">C02679/11</a>   BOOL	Status signal "Actual position in the target" <ul style="list-style-type: none"> <li>In the case of sequence profiles, the target position of the last profile to be processed.</li> <li>▶ <a href="#">Actual value-based evaluation "Target position reached"</a> (□ 485)</li> </ul>			
	<table border="1"> <tr> <td>FALSE</td> <td>Positioning is still active or has been aborted.</td> </tr> <tr> <td>TRUE</td> <td>The current actual position value of the drive has reached the target of the last profile to be traversed within the tolerance window set in <a href="#">C02670</a>.</td> </tr> </table>	FALSE	Positioning is still active or has been aborted.	TRUE
FALSE	Positioning is still active or has been aborted.			
TRUE	The current actual position value of the drive has reached the target of the last profile to be traversed within the tolerance window set in <a href="#">C02670</a> .			
POS_bDriveInTarget <a href="#">C02679/12</a>   BOOL From V5.0	Status signal "Drive in target" <ul style="list-style-type: none"> <li>In the case of sequence profiles, the target position of the last profile to be processed.</li> <li>The status is also output when the basic function "Positioning" is deactivated.</li> <li>▶ <a href="#">Actual value- and setpoint-based evaluation "Drive in the target"</a> (□ 486)</li> </ul>			
	<table border="1"> <tr> <td>FALSE</td> <td>Positioning is still active or has been aborted.</td> </tr> </table>	FALSE	Positioning is still active or has been aborted.	
	FALSE	Positioning is still active or has been aborted.		
	<table border="1"> <tr> <td>FALSE↗TRUE</td> <td>The current actual position value of the drive has reached the target position within the profile to be traversed last within the tolerance window set in <a href="#">C02671</a>. At this time, the current position setpoint has already reached the target position. <ul style="list-style-type: none"> <li>In positioning processes with sequence profiles, the output will only be set to TRUE when the last profile has been processed.</li> </ul> </td> </tr> </table>	FALSE↗TRUE	The current actual position value of the drive has reached the target position within the profile to be traversed last within the tolerance window set in <a href="#">C02671</a> . At this time, the current position setpoint has already reached the target position. <ul style="list-style-type: none"> <li>In positioning processes with sequence profiles, the output will only be set to TRUE when the last profile has been processed.</li> </ul>	
	FALSE↗TRUE	The current actual position value of the drive has reached the target position within the profile to be traversed last within the tolerance window set in <a href="#">C02671</a> . At this time, the current position setpoint has already reached the target position. <ul style="list-style-type: none"> <li>In positioning processes with sequence profiles, the output will only be set to TRUE when the last profile has been processed.</li> </ul>		
<table border="1"> <tr> <td>TRUE↘FALSE</td> <td>The current actual position value of the drive has exited the tolerance and hysteresis window set in <a href="#">C02671</a> and <a href="#">C02672</a> again after a positioning process has been completed.</td> </tr> </table>	TRUE↘FALSE	The current actual position value of the drive has exited the tolerance and hysteresis window set in <a href="#">C02671</a> and <a href="#">C02672</a> again after a positioning process has been completed.		
TRUE↘FALSE	The current actual position value of the drive has exited the tolerance and hysteresis window set in <a href="#">C02671</a> and <a href="#">C02672</a> again after a positioning process has been completed.			
<table border="1"> <tr> <td>FALSE↗TRUE (once again)</td> <td>If <a href="#">C02673</a> = "1", a modulo evaluation is carried out in all cycles (Lenze setting): <ul style="list-style-type: none"> <li>The output is set to TRUE again if the current actual position value of the drive enters the tolerance and hysteresis window <u>in an optional modulo cycle</u> again.</li> </ul> If <a href="#">C02673</a> = "0", a modulo evaluation is only carried out in the modulo cycle of the target setpoint: <ul style="list-style-type: none"> <li>The output is set to TRUE again if the current actual position value of the drive enters the tolerance and hysteresis window <u>in the same modulo cycle</u> again.</li> </ul> </td> </tr> </table>	FALSE↗TRUE (once again)	If <a href="#">C02673</a> = "1", a modulo evaluation is carried out in all cycles (Lenze setting): <ul style="list-style-type: none"> <li>The output is set to TRUE again if the current actual position value of the drive enters the tolerance and hysteresis window <u>in an optional modulo cycle</u> again.</li> </ul> If <a href="#">C02673</a> = "0", a modulo evaluation is only carried out in the modulo cycle of the target setpoint: <ul style="list-style-type: none"> <li>The output is set to TRUE again if the current actual position value of the drive enters the tolerance and hysteresis window <u>in the same modulo cycle</u> again.</li> </ul>		
FALSE↗TRUE (once again)	If <a href="#">C02673</a> = "1", a modulo evaluation is carried out in all cycles (Lenze setting): <ul style="list-style-type: none"> <li>The output is set to TRUE again if the current actual position value of the drive enters the tolerance and hysteresis window <u>in an optional modulo cycle</u> again.</li> </ul> If <a href="#">C02673</a> = "0", a modulo evaluation is only carried out in the modulo cycle of the target setpoint: <ul style="list-style-type: none"> <li>The output is set to TRUE again if the current actual position value of the drive enters the tolerance and hysteresis window <u>in the same modulo cycle</u> again.</li> </ul>			
POS_dnSetPos_p <a href="#">C02678/1</a>   DINT	Current position setpoint in [increments] <ul style="list-style-type: none"> <li>Reference point is the home position.</li> </ul>			
POS_dnProfileTarget_p <a href="#">C02678/2</a>   DINT	Target position of the current profile in [increments] <ul style="list-style-type: none"> <li>Reference point is the home position.</li> </ul>			
POS_dnProfileSpeed_s <a href="#">C02676</a>   DINT	Current setpoint speed of the current profile as speed in [rpm] <ul style="list-style-type: none"> <li>Taking a speed override into consideration.</li> </ul>			
POS_dwActualProfileNumber <a href="#">C02674</a>   DWORD	Profile number (1 .... 100) of the current profile			

Identifier DIS code   data type	Value/meaning
POS_dnSetPosRelative_p From V5.0 <a href="#">C02678/3</a>   DINT	Current relative position setpoint of the current positioning in [increments] <ul style="list-style-type: none"> <li>• The value is also output if the basic function "Positioning" is deactivated.</li> <li>• Reference point is the starting position of the current profile.</li> <li>• After a positioning process has been completed, the output keeps the last relative value of the setpoint profile.</li> <li>• The output is reset when a new positioning is started, or when the home position is set.</li> </ul>
POS_dnActPosRelative_p From V5.0 <a href="#">C02678/4</a>   DINT	Current relative actual position value of the current positioning in [increments] <ul style="list-style-type: none"> <li>• The value is also output if the basic function "Positioning" is deactivated.</li> <li>• Reference point is the starting position of the current profile.</li> <li>• The output follows the current position even if the basic function "Positioning" is no longer active.</li> <li>• The output is reset when a new positioning is started, or when the home position is set.</li> </ul>

### 11.7.1.1 Possibilities for the selection of the profile

For specifying as well as storing and managing (travel) profiles, the following function blocks are available:

Function block	Job title
L_PosPositionerTable	...serves to store and manage up to 100 (travel) profiles and to "Teach" positions, speeds, accelerations/decelerations and S-ramp times. <ul style="list-style-type: none"> <li>• A further important task of this FB is the conversion of the table values according to the preselected scaling in the <b>LS_DriveInterface</b> SB.</li> </ul>
L_PosProfileTable	...serves to store and manage up to four (travel) profiles and allows the "teaching" of target positions. <ul style="list-style-type: none"> <li>• In contrast to the FB <b>L_PosPositionerTable</b> this FB does not use any variable tables but the data of the profile parameters are entered directly into the assigned codes.</li> <li>• The position at the input <i>dnExtPos_p</i> is used as target position as a further specific feature for the selection of profile no. 1.</li> </ul>
L_PosProfileInterface	...provides a profile data set for the <b>LS_Positioner</b> SB.

#### Related topics:

- ▶ [Setting the S-ramp time](#) (📖 387)

### 11.7.2 Parameter setting

Setting parameters is not required for the basic function "Positioning".

- After activating the function, the profile is executed which has been transferred from the application to the basic function via the input *POS\_ProfileData*.
- For profiles with touch probe positioning mode (residual path positioning) touch probe is detected implicitly.

**Related topics:**

▶ [Setting the S-ramp time](#) (📖 387)

#### 11.7.2.1 Actual value-based evaluation "Target position reached"

An actual value-based evaluation on whether the drive has reached the target position can be carried out by means of the output *POS\_bActPosInTarget* and parameterisation of [C02670](#).

- The output *POS\_bActPosInTarget* is set to TRUE if the current actual position value of the drive has reached the target position of the profile to be traversed last within the tolerance window set in [C02670](#).
  - Hence, for sequence profiles the evaluation is only valid for the target position of the last profile.
- If [C02670](#) is set to "0" (Lenze setting), the evaluation is setpoint-based and the signal at the *POS\_bActPosInTarget* output corresponds to the *POS\_bDone* signal.



**Tip!**

In many cases the signal *POS\_bActPosInTarget* only has to be evaluated if the setpoint has also reached the target position. This can for instance be implemented in the function block editor by a logic "AND" operation with the signal *POS\_bDone*.

From software version V5.0 it is displayed whether the set position and the actual position are in the target via the output *POS\_bDriveInTarget*. ▶ [Actual value- and setpoint-based evaluation "Drive in the target"](#) (📖 486)

### 11.7.2.2 Actual value- and setpoint-based evaluation "Drive in the target"

This function extension is available from software version V5.0 onwards!

An actual value- and setpoint-based evaluation on whether the drive is in the target can be carried out by means of the output *POS\_bDriveInTarget* and parameterisation of [C02671](#), [C02672](#), and [C02673](#).

- The output *POS\_bDriveInTarget* is set to TRUE if the current actual position value of the drive has reached the target position of the profile to be traversed last within the tolerance window set in [C02671](#).
  - At this time, the current setpoint value has already reached the target position, i. e. the actual position and set position are in the target.
  - In positioning processes with sequence profiles, the output will only be set to TRUE when the last profile has been processed.
- The output *POS\_bDriveInTarget* is reset to FALSE if the current actual position value of the drive has exited the tolerance and hysteresis window set in [C02671](#) and [C02672](#) again after a positioning process has been completed.
- How the modulo evaluation is to be carried out if the actual position value enters the tolerance and hysteresis window again can be set in [C02673](#):
  - Modulo evaluation in all cycles (Lenze setting):  
The output *POS\_bDriveInTarget* is set to TRUE again if the current actual position value of the drive enters the tolerance window again in an optional modulo cycle.
  - Modulo evaluation only in the modulo cycle of the target setpoint:  
The output *POS\_bDriveInTarget* is set to TRUE again if the current actual position value of the drive enters the tolerance window again in the same modulo cycle.
- A new FALSE $\rightarrow$ TRUE edge at the output *POS\_bDriveInTarget* after a positioning process has been completed can for instance occur when the basic function is deactivated afterwards, and if the drive axis is skewed so that the tolerance and hysteresis window is exited and then the tolerance range is entered again.

#### Short overview of the parameters for the actual value- and setpoint-based evaluation:

Parameters	Info	Lenze setting	
		Value	Unit
<a href="#">C02671</a>	Tolerance for target position	2.0000	Unit
<a href="#">C02672</a>	Hysteresis for target position	1.0000	Unit
<a href="#">C02673</a>	Activate DriveInTarget Modulo	All cycles	

### 11.7.3 Carrying out positioning

#### Prerequisites

- The controller is in the "Operation" device state.
- The basic function "Positioning" is part of the active application.
- No other basic function is active.

#### Activation

To request the control via the basic function, the *POS\_bEnable* enable input in the application must be set to TRUE.

- If no other basic function is active, a change-over to the "Positioning active" function state is effected and positioning can be carried out via the control inputs.
- A successful change to the function state "Positioning active" is displayed by a TRUE signal at the *POS\_bEnabled* status output.

#### Deactivation

When the *POS\_bEnable* enable input is reset to FALSE, an active positioning is stopped, i.e. the control inputs for positioning are inhibited and the drive is braked to standstill within the deceleration time for stop.

- The status output *POS\_bEnabled* is reset to FALSE and a change-over from the active "Positioning active" function state via the "Drive is stopped" function state back to the basic state "Drive at standstill" is carried out.

#### 11.7.3.1 Start positioning

By setting the control input *POS\_bStart* to TRUE, the positioning process is started.

- The (travel) profile that has been transferred to the basic function via the input *POS\_ProfileData* is traversed.

#### 11.7.3.2 Aborting/interrupting positioning

By setting the control input *POS\_bAbort* to TRUE, the active positioning can be aborted or interrupted.

- The current profile is not completed but braked to standstill with the deceleration defined in the profile data.
- If the control input *POS\_bAbort* remains on TRUE, a restart or the continuation of an interrupted positioning is inhibited.
- After resetting the control input *POS\_bAbort* to FALSE, a restart or the continuation of an interrupted positioning process is possible again.

---

### 11.7.3.3 Continue interrupted positioning

By setting the control input *POS\_bRestart* to TRUE, an interrupted positioning process can be continued if the control input *POS\_bAbort* has been reset to FALSE before.

- Distances of a relative positioning already covered are taken into account.
- If the continuation of a positioning process via the input *POS\_bRestart* is not possible, this is displayed via bit 11 of the status output *POS\_dnState*.

The following applies to software versions lower than V3.0:

- If during an active or cancelled positioning process a change-over to the states "Quick stop active", "Drive is stopped", or "Drive at standstill" is effected, it is also possible to continue a positioning process via *POS\_bRestart*, taking the distance that has already been covered into consideration.

The following applies from software version V3.0:

- If during an active or cancelled positioning process a change-over is effected (e. g. by activating a quick stop or inhibiting the controller), it is also possible to continue a positioning process via *POS\_bRestart*, taking the distance that has already been covered into consideration.
- However, after a homing has been carried out again, or after the following machine parameters have been changed, a continuation of an interrupted positioning process via the control input *POS\_bRestart* is no longer possible:
  - Encoder resolution ([C00100](#))
  - Position encoder selection ([C00490](#)), motor encoder selection ([C00495](#))
  - Gearbox factors ([C02520](#), [C02521](#), [C02522](#), [C02523](#))
  - Feed constant ([C02524](#))
  - Motor mounting direction ([C02527](#)), position encoder mounting direction ([C02529](#))
  - Traversing range ([C02528](#))
  - Cycle ([C02536](#)) for modulo traversing range
  - Position control structure ([C02570](#))



### 11.7.3.4 Activate override

An "Override" is the change of profile parameters and their acceptance during the positioning process.

- When the input *POS\_bEnableOverride* is set to TRUE, a speed and acceleration override occurs according to the override values applied to the inputs *POS\_dnSpeedOverride\_n* and *POS\_dnAccOverride\_n*.
  - The override values represent percentage multipliers with regard to the current profile parameters for speed and acceleration.
  - For override values  $\leq 1\%$  a status bit is set.
  - Override values  $\leq 0\%$  are internally set to  $0\%$ .
  - Changes of the override values are accepted in each cycle.



#### Note!

The online change of speed and acceleration is in effect from the start of the profile until the deceleration phase begins. Changing the deceleration phase by means of an override is therefore not possible!

- In the case of an override value of  $0\%$  for the speed, the drive is brought to a standstill.
- In the case of an override value of  $0\%$  for the acceleration, acceleration does not take place any longer.

- From software version V5.0 also a deceleration override via the input *POS\_dnDecOverride\_n* can be carried out if the input *POS\_bEnableOverride* is set to TRUE.

The deceleration override is effective:

- During the deceleration phase of a profile
- During an abort process
- In the case of a speed change-over from a high to a low speed within a profile (e. g. if the speed override is used)



#### Note!

If the override value for deceleration is  $0\%$ , there is no deceleration, i. e. the drive does not come to a standstill!

- If the input *POS\_bEnableOverride* is reset to FALSE again, the speeds, accelerations, and decelerations are run again, which have been defined via the profile parameters. There is an immediate acceleration from the override speed to the speed set in the profile.

## 11.8 Position follower

This basic function is used as setpoint interface for position-controlled drives.

- The specified position setpoint can either refer to the encoder on the motor side or to the (position) encoder used additionally to detect the machine position. The selection of the encoder configuration serves to adapt the internal control structure accordingly.
- Instead of a position setpoint alternatively also a speed setpoint can be specified by an according selection in [C02680](#); the set position is then calculated by the integration of the speed setpoint on the basis of the current actual position (relative positioning).
- If the direction of rotation of the motor has to be inverted due to the mounting position of the motor or the gearbox ratio available, the use of the control signals can be accordingly changed over by means of parameterisation.
- The speed feedforward control can also be executed with the position setpoint by a corresponding selection in [C02681](#). Then, the speed is calculated by differentiation of the position setpoint.



### Stop!

If a limit switch is approached by means of the basic function "Position follower" and by this a fault with the "Quick stop by trouble" response is activated, always a set/actual adjustment of the position has to be carried out before the fault is acknowledged, as otherwise an uncontrolled motor movement may result after the fault is acknowledged!

▶ [Hardware limit positions \(limit switch\)](#) (📖 515)



### Note!

When the basic function is activated, a start acceleration is considered. ▶ [Start acceleration/acceleration reduction when the basic function changes](#) (📖 385)

**For the encoderless motor control types (from software version V3.0) the following applies:**

The basic function "Position follower" can only be activated for V/f control or sensorless vector control if the position controller has been selected for the position control ([C02570](#) = "2: position controller active").

### 11.8.1 Internal interfaces | "LS\_PositionFollower" system block

The **LS\_PositionFollower** system block provides the internal interfaces for the basic function "Position follower" in the function block editor.

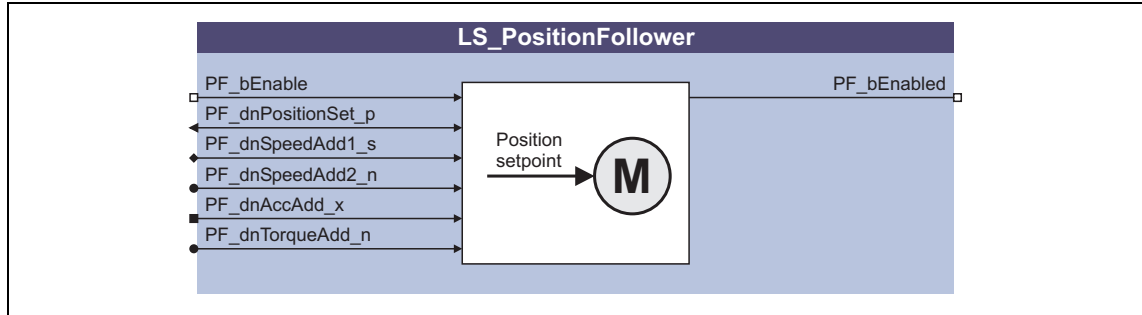

#### Note!

Ensure that the system block is called in a cyclic application task.

Basically, projects which only contain an unsolicited task and no cyclic task are not permissible!

#### Inputs

Identifier <small>DIS code   data type</small>	Information/possible settings				
PF_bEnable <a href="#">C02689/1</a>   BOOL	Request control of basic function <table border="1"> <tr> <td>TRUE</td> <td>If no other basic function is active, a change-over to the "Position follower active" function state is carried out, and the setpoints defined are accepted.</td> </tr> <tr> <td>TRUE⇒FALSE</td> <td>If no other basic function takes over the control of the drive, the drive is brought to standstill, i. e. a change-over from the active function state "Position follower active" via the "Drive is stopped" function state back to the basic state "Drive at standstill" is carried out.</td> </tr> </table>	TRUE	If no other basic function is active, a change-over to the "Position follower active" function state is carried out, and the setpoints defined are accepted.	TRUE⇒FALSE	If no other basic function takes over the control of the drive, the drive is brought to standstill, i. e. a change-over from the active function state "Position follower active" via the "Drive is stopped" function state back to the basic state "Drive at standstill" is carried out.
TRUE	If no other basic function is active, a change-over to the "Position follower active" function state is carried out, and the setpoints defined are accepted.				
TRUE⇒FALSE	If no other basic function takes over the control of the drive, the drive is brought to standstill, i. e. a change-over from the active function state "Position follower active" via the "Drive is stopped" function state back to the basic state "Drive at standstill" is carried out.				
PF_dnPositionSet_p <a href="#">C02688/1</a>   DINT	Position setpoint in [increments]				
PF_dnSpeedAdd1_s <a href="#">C02686</a>   DINT	Speed feedforward control value in [rpm]				
PF_dnSpeedAdd2_n <a href="#">C02687/1</a>   DINT	Additional speed setpoint in [%] • 100 % ≙ Motor reference speed ( <a href="#">C00011</a> )				
PF_dnAccAdd_x <a href="#">C02685</a>   DINT	Motor acceleration • For calculating the acceleration torque (for setting <a href="#">C00276</a> = "0"). • Selection as speed variation/time in [rpm/s]				
PF_dnTorqueAdd_n <a href="#">C02687/2</a>   DINT	Additive torque feedforward control value in [%] • 100 % ≙ motor reference torque (display in <a href="#">C00057/2</a> ).				

#### Outputs

Identifier <small>DIS code   data type</small>	Value/meaning		
PF_bEnabled <a href="#">C02689/2</a>   BOOL	Status signal "Basic function is enabled" <table border="1"> <tr> <td>TRUE</td> <td>The defined setpoints are accepted.</td> </tr> </table>	TRUE	The defined setpoints are accepted.
TRUE	The defined setpoints are accepted.		

11.8.2 Signal flow

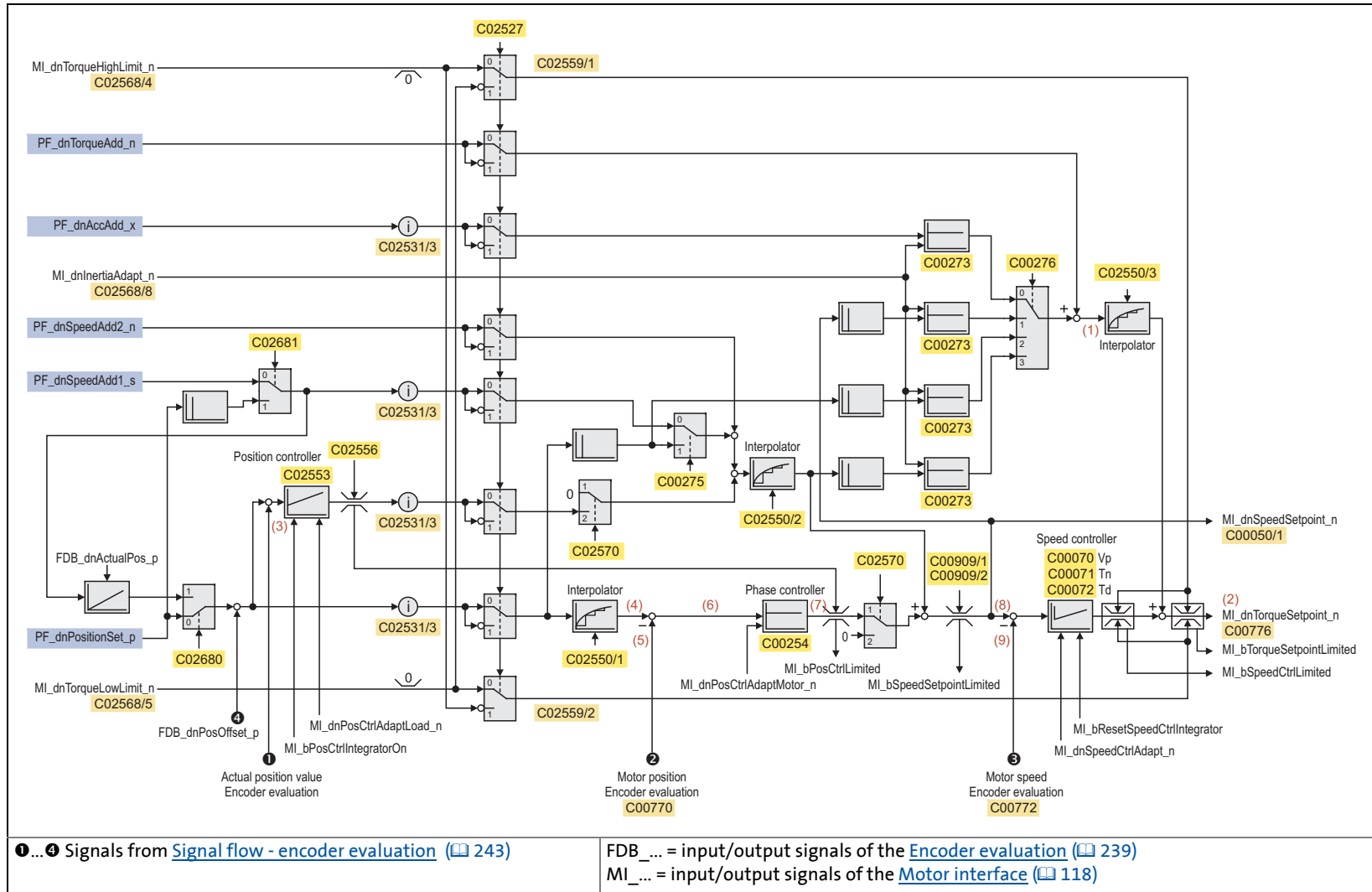

[11-22] Signal flow - position follower

**Internal variables of the motor control (oscilloscope signals)**

- The red numbers in brackets listed in the signal flow stand for internal variables of the motor control, which you can record by means of the [Oscilloscope](#) for purposes of diagnostics and documentation. ([📄 585](#))

No.	Variable of the motor control	Meaning
(1)	Torque.dnTotalTorqueAdd	Additive torque feedforward control value
(2)	Torque.dnTorqueSetpoint	Torque setpoint
(3)	Position.dnActualLoadPos	Actual position
(4)	Position.dnPositionSetpoint	Position setpoint
(5)	Position.dnActualMotorPos	Current motor position
(6)	Position.dnContouringError	Following error
(7)	Speed.dnOutputPosCtrl	Output signal - phase controller
(8)	Speed.dnSpeedSetpoint	Speed setpoint
(9)	Speed.dnActualMotorSpeed	Current motor speed

### 11.8.3 Parameter setting

- Parameterisation dialog in »Engineer«: Tab **Application parameters** → Dialog level *Overview* → *All basic functions* → *Position follower*
- Short overview of the parameters for the position follower:

Parameters	Info
<a href="#">C00050/1</a>	Speed setpoint 1 [rpm]
<a href="#">C00070</a>	Speed controller gain
<a href="#">C00071</a>	Speed controller reset time
<a href="#">C00072</a>	Speed controller rate time
<a href="#">C00273/1</a>	Motor moment of inertia
<a href="#">C00273/2</a>	Load moment of inertia
<a href="#">C00275</a>	Signal source - speed setpoint
<a href="#">C00276</a>	Signal source - torque setpoint
<a href="#">C00909/1</a>	Upper speed limit value
<a href="#">C00909/2</a>	Lower speed limit value
<a href="#">C02520</a>	Gearbox factor numerator: Motor
<a href="#">C02521</a>	Gearbox factor denom.: Motor
<a href="#">C02522</a>	Gearbox factor num.: Pos. enc.
<a href="#">C02523</a>	Gearbox fac. denom.: Pos. enc.
<a href="#">C02527</a>	Motor mounting direction
<a href="#">C02550/1</a>	Position setpoint interpolat.
<a href="#">C02550/2</a>	Speed setpoint interpolation
<a href="#">C02550/3</a>	Torque setpoint interpolation
<a href="#">C02553</a>	Position controller gain
<a href="#">C02554</a>	Position controller reset time
<a href="#">C02555</a>	D component position controller
<a href="#">C02559</a>	Internal torque limit
<a href="#">C02680</a>	Source position setpoint
<a href="#">C02681</a>	Source add. speed
Greyed out = display parameter	

### 11.8.3.1 Setpoint interpolation

When the setpoint interpolation is activated, the motor control creates intermediate values to "smoothly" follow the setpoints which may be transferred from a slower task.

- [C02550/1](#) = "1": The motor control follows the position setpoint in interpolated steps.
- [C02550/2](#) = "1": The motor control follows the speed setpoint in interpolated steps.
- [C02550/3](#) = "1": The motor control follows the torque setpoint in interpolated steps.

### 11.8.3.2 Inversion of the direction of rotation

Depending on the motor mounting position, if required, the direction of rotation can be inverted:

- [C02527](#) = "0": Clockwise rotating motor  $\equiv$  positive machine direction.
- [C02527](#) = "1": Counter-clockwise rotating motor  $\equiv$  positive machine direction.

#### 11.8.4 Activating setpoint interface

##### Prerequisites

- The controller is in the "Operation" device state.
- The basic function "Position follower" is part of the active application.
- No other basic function is active.

##### Activation

To request the control via the basic function, the *PF\_bEnable* enable input in the application must be set to TRUE.

- If no other basic function is active, a change-over to the "Position follower active" function state is carried out. Setpoints can now be defined via the corresponding inputs. ▶ [Signal flow](#)
- A successful change to the "Position follower active" function state is displayed by a TRUE signal at the status output *PF\_bEnabled*.



### Stop!

The basic function does not take over the control of the drive from the current speed, but immediately with the setpoint defined, which may cause a jerk!

##### Deactivation

When the *PF\_bEnable* enable input is reset to FALSE, the setpoint inputs are inhibited. If the drive is not at standstill, it is braked to standstill within the deceleration time set for stop unless another basic function takes over the control of the drive.

- The status output *PF\_bEnabled* is reset to FALSE and a change-over from the active "Position follower active" function state via the "Drive is stopped" function state back to the basic state "Drive at standstill" is carried out.



### 11.9 Speed follower

This basic function is used as setpoint interface for speed-controlled drives.

- The motor control is switched over automatically to speed control with torque limitation.
- If the direction of rotation of the motor has to be inverted due to the mounting position of the motor or the gearbox ratio available, the use of the control signals can be accordingly changed over by means of parameterisation.



#### Note!

When the basic function is activated, a start acceleration is considered. ▶ [Start acceleration/acceleration reduction when the basic function changes](#) (385)

#### 11.9.1 Internal interfaces | "LS\_SpeedFollower" system block

The **LS\_SpeedFollower** system block provides the internal interfaces for the basic function "Speed follower" in the function block editor.

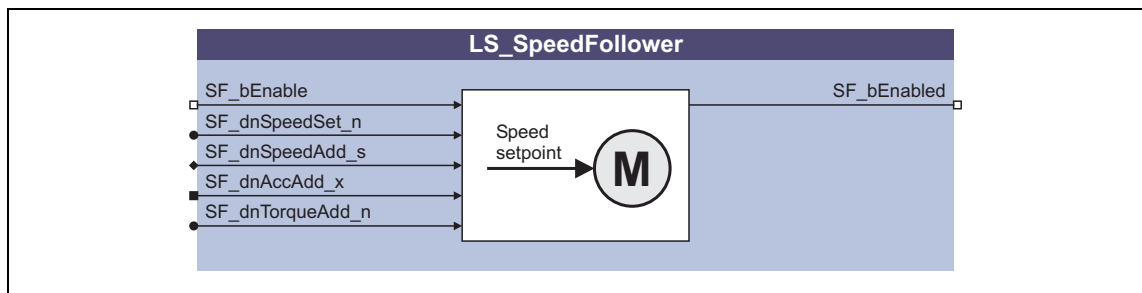

#### Note!

Ensure that the system block is called in a cyclic application task.

Basically, projects which only contain an unsolicited task and no cyclic task are not permissible!

#### Inputs

Identifier <small>DIS code   data type</small>	Information/possible settings				
SF_bEnable <a href="#">C02695/1</a>   BOOL	Request control of basic function <table border="1"> <tr> <td>TRUE</td> <td>If no other basic function is active, a change-over to the "Speed follower active" function state is carried out, and the setpoints defined are accepted.</td> </tr> <tr> <td>TRUE↔FALSE</td> <td>If no other basic function takes over the control of the drive, the drive is brought to standstill, i. e. a change-over from the active function state "Speed follower active" via the "Drive is stopped" function state back to the basic state "Drive at standstill" is carried out.</td> </tr> </table>	TRUE	If no other basic function is active, a change-over to the "Speed follower active" function state is carried out, and the setpoints defined are accepted.	TRUE↔FALSE	If no other basic function takes over the control of the drive, the drive is brought to standstill, i. e. a change-over from the active function state "Speed follower active" via the "Drive is stopped" function state back to the basic state "Drive at standstill" is carried out.
TRUE	If no other basic function is active, a change-over to the "Speed follower active" function state is carried out, and the setpoints defined are accepted.				
TRUE↔FALSE	If no other basic function takes over the control of the drive, the drive is brought to standstill, i. e. a change-over from the active function state "Speed follower active" via the "Drive is stopped" function state back to the basic state "Drive at standstill" is carried out.				
SF_dnSpeedSet_n <a href="#">C02694/1</a>   DINT	Speed setpoint in [%] <ul style="list-style-type: none"> <li>• 100 % ≙ Motor reference speed (<a href="#">C00011</a>)</li> </ul>				
SF_dnSpeedAdd_s <a href="#">C02693</a>   DINT	Additive speed setpoint in [rpm] <ul style="list-style-type: none"> <li>• Without position control function.</li> </ul>				

Identifier DIS code   data type	Information/possible settings
SF_dnAccAdd_x <a href="#">C02692</a>   DINT	Motor acceleration <ul style="list-style-type: none"> <li>• For calculating the acceleration torque (for setting <a href="#">C00276</a> = "0").</li> <li>• Selection as speed variation/time in [rpm/s]</li> </ul>
SF_dnTorqueAdd_n <a href="#">C02694/2</a>   DINT	Additive torque feedforward control value in [%] <ul style="list-style-type: none"> <li>• 100 % ≙ motor reference torque (display in <a href="#">C00057/2</a>).</li> </ul>

### Outputs

Identifier DIS code   data type	Value/meaning
SF_bEnabled <a href="#">C02695/2</a>   BOOL	Status signal "Basic function is enabled"
	TRUE   The defined setpoints are accepted.

### 11.9.2 Signal flow

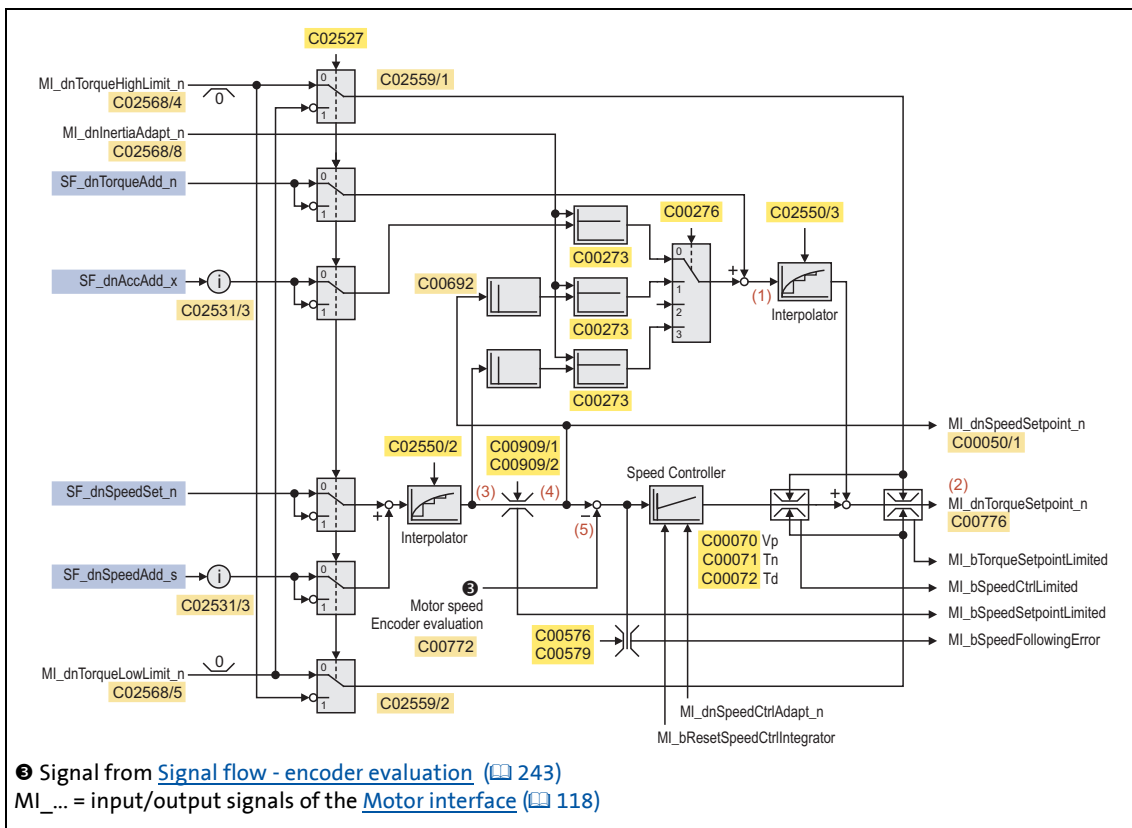

[11-23] Signal flow - speed follower

#### Internal variables of the motor control (oscilloscope signals)

- The red numbers in brackets listed in the signal flow stand for internal variables of the motor control, which you can record by means of the [Oscilloscope](#) for purposes of diagnostics and documentation. (📖 585)

No.	Variable of the motor control	Meaning
(1)	Torque.dnTotalTorqueAdd	Additive torque feedforward control value
(2)	Torque.dnTorqueSetpoint	Torque setpoint
(3)	Speed.dnTotalSpeedAdd	Additive speed setpoint
(4)	Speed.dnSpeedSetpoint	Speed setpoint
(5)	Speed.dnActualMotorSpeed	Current motor speed

### 11.9.3 Parameter setting

- Parameterisation dialog in »Engineer«: Tab **Application parameters** → Dialog level *Overview* → *All basic functions* → *Speed follower*
- Short overview of the parameters for the speed follower:

Parameters	Info
<a href="#">C00050/1</a>	Speed setpoint 1
<a href="#">C00070</a>	Speed controller gain
<a href="#">C00071</a>	Speed controller reset time
<a href="#">C00072</a>	Speed controller rate time
<a href="#">C00273/1</a>	Motor moment of inertia
<a href="#">C00273/2</a>	Load moment of inertia
<a href="#">C00276</a>	Signal source - torque setpoint
<a href="#">C00576</a>	Speed monitoring window
<a href="#">C00579</a>	Resp. to speed monitoring
<a href="#">C00909/1</a>	Upper speed limit value
<a href="#">C00909/2</a>	Lower speed limit value
<a href="#">C02520</a>	Gearbox factor numerator: Motor
<a href="#">C02521</a>	Gearbox factor denom.: Motor
<a href="#">C02522</a>	Gearbox factor num.: Pos. enc.
<a href="#">C02523</a>	Gearbox fac. denom.: Pos. enc.
<a href="#">C02527</a>	Motor mounting direction
<a href="#">C02531/3</a>	Effective gearbox factor (dec.)
<a href="#">C02550/2</a>	Speed setpoint interpolation
<a href="#">C02550/3</a>	Torque setpoint interpolation
<a href="#">C02570</a>	Position control structure
<a href="#">C02559</a>	Internal torque limit

Greyed out = display parameter

#### 11.9.3.1 Setpoint interpolation

When the setpoint interpolation is activated, the motor control creates intermediate values to "smoothly" follow the speed and/or torque setpoints which may be transferred from a slower task.

- [C02550/2](#) = "1": The motor control follows the speed setpoint in interpolated steps.
- [C02550/3](#) = "1": The motor control follows the torque setpoint in interpolated steps.

#### 11.9.3.2 Inversion of the direction of rotation

Depending on the motor mounting position, if required, the direction of rotation can be inverted:

- [C02527](#) = "0": Clockwise rotating motor ≡ positive machine direction.
- [C02527](#) = "1": Counter-clockwise rotating motor ≡ positive machine direction.

#### 11.9.4 Activating setpoint interface

##### Prerequisites

- The controller is in the "Operation" device state.
- The basic function "Speed follower" is part of the active application.
- No other basic function is active.

##### Activation

To request the control via the basic function, the *SF\_bEnable* enable input in the application must be set to TRUE.

- If no other basic function is active, a change-over to the "Speed follower active" function state is carried out, and the motor control is automatically switched over to speed control with torque limitation. Setpoints can now be defined via the corresponding inputs. ▶ [Signal flow](#)
- A successful change to the function state "Speed follower active" is displayed by a TRUE signal at the *SF\_bEnabled* status output.



### Stop!

The basic function does not take over the control of the drive from the current speed, but immediately with the setpoint defined, which may cause a jerk!

##### Deactivation

When the *SF\_bEnable* enable input is reset to FALSE, the setpoint inputs are inhibited. If the drive is not at standstill, it is braked to standstill within the deceleration time set for stop unless another basic function takes over the control of the drive.

- The status output *SF\_bEnabled* is reset to FALSE and a change-over from the active "Speed follower active" function state via the "Drive is stopped" function state back to the basic state "Drive at standstill" is carried out.

### 11.10 Torque follower

This basic function is used as setpoint interface for torque-controlled drives.

- The motor control is switched over automatically to torque control with speed limitation.
- If the direction of rotation of the motor has to be inverted due to the mounting position of the motor or the gearbox ratio available, the use of the control signals can be accordingly changed over by means of parameterisation.
- A stable speed limitation requires a minimum difference of the speed limit values of 50 rpm. If the defined speed limit values fall below this minimum difference, the internal lower speed limit value is lowered accordingly. The upper speed limit value remains unchanged. ▶ [Signal flow - torque follower](#) (□ 503)



#### Note!

When the basic function is activated, a start acceleration is considered. ▶ [Start acceleration/acceleration reduction when the basic function changes](#) (□ 385)

**For the encoderless motor control types (from software version V3.0) the following applies:**

The basic function "Torque follower" cannot be activated when the V/f control has been selected.

### 11.10.1 Internal interfaces | "LS\_TorqueFollower" system block

The **LS\_TorqueFollower** system block provides the internal interfaces for the basic function "Torque follower" in the function block editor.

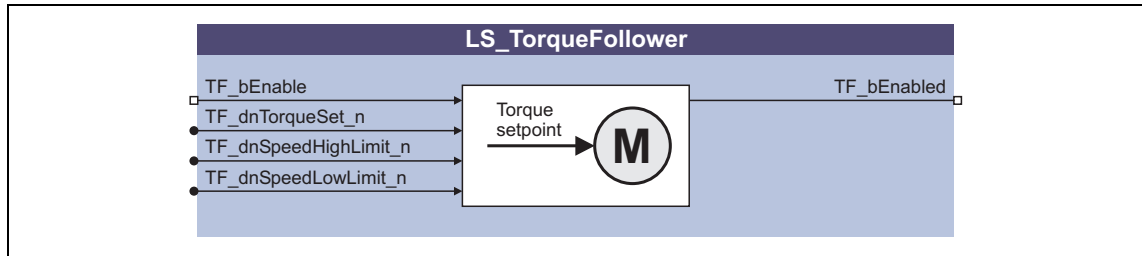

#### Note!

Ensure that the system block is called in a cyclic application task.

Basically, projects which only contain an unsolicited task and no cyclic task are not permissible!

#### Inputs

Identifier <small>DIS code   data type</small>	Information/possible settings
TF_bEnable <a href="#">C02699/1</a>   BOOL	Request control of basic function
	TRUE If no other basic function is active, a change-over to the "Torque follower active" function state is carried out, and the setpoints defined are accepted.
	TRUE↔FALSE If no other basic function takes over the control of the drive, the drive is brought to standstill, i. e. a change-over from the active function state "Torque follower active" via the "Drive is stopped" function state back to the basic state "Drive at standstill" is carried out.
TF_dnTorqueSet_n <a href="#">C02698/1</a>   DINT	Torque setpoint in [%] • 100 % ≙ motor reference torque (display in <a href="#">C00057/2</a> ).
TF_dnSpeedHighLimit_n <a href="#">C02698/2</a>   DINT	Upper speed limit value in [%] for speed limitation • For positive direction of motion. • 100 % ≙ Motor reference speed ( <a href="#">C00011</a> ). • Negative values are limited internally to the value "0".
TF_dnSpeedLowLimit_n <a href="#">C02698/3</a>   DINT	Lower speed limit value in [%] for speed limitation • For negative direction of motion. • 100 % ≙ Motor reference speed ( <a href="#">C00011</a> ). • Positive values are limited internally to the value "0".

#### Outputs

Identifier <small>DIS code   data type</small>	Value/meaning
TF_bEnabled <a href="#">C02699/2</a>   BOOL	Status signal "Basic function is enabled"
	TRUE The defined setpoints are accepted.

### 11.10.2 Signal flow

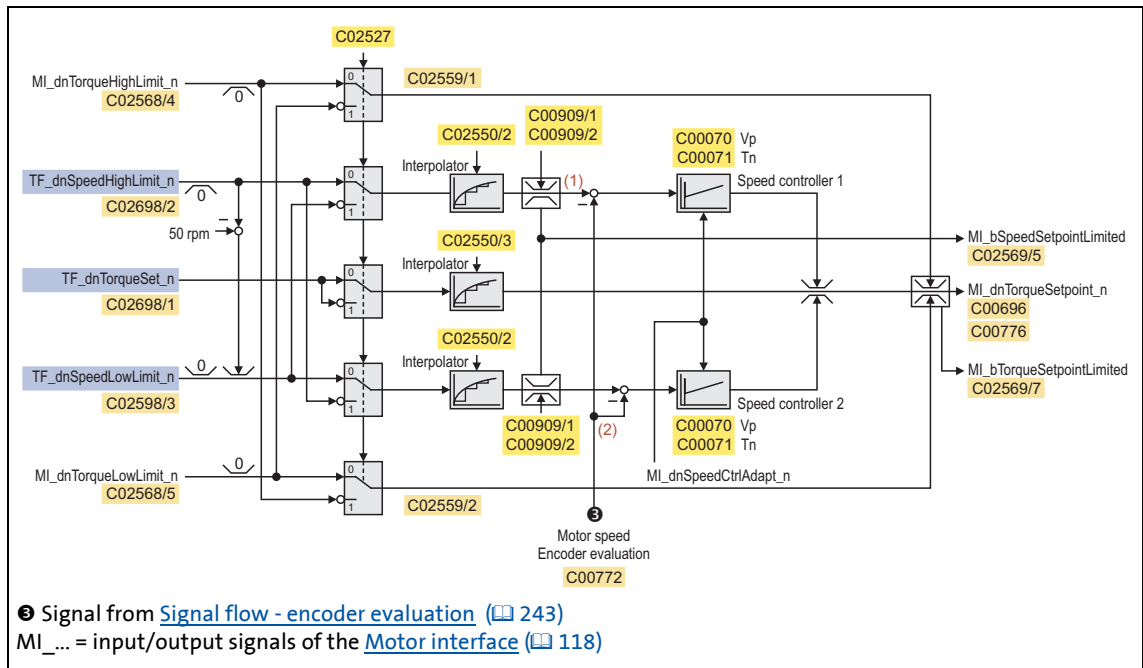

[11-24] Signal flow - torque follower

#### Internal variables of the motor control (oscilloscope signals)

- The red numbers in brackets listed in the signal flow stand for internal variables of the motor control, which you can record by means of the [Oscilloscope](#) for purposes of diagnostics and documentation. (📖 585)

No.	Variable of the motor control	Meaning
(1)	Speed.dnSpeedSetpoint	Speed setpoint
(2)	Speed.dnActualMotorSpeed	Current motor speed



# 11 Basic drive functions

## 11.10 Torque follower

### 11.10.3 Parameter setting

- Parameterisation dialog in »Engineer«: Tab **Application parameters** → Dialog level *Overview* → *All basic functions* → *Torque follower*
- Short overview of the parameters for the torque follower:

Parameters	Info
<a href="#">C00050/1</a>	Speed setpoint 1
<a href="#">C00050/2</a>	Speed setpoint 2
<a href="#">C00070</a>	Speed controller gain
<a href="#">C00071</a>	Speed controller reset time
<a href="#">C00909/1</a>	Upper speed limit value
<a href="#">C00909/2</a>	Lower speed limit value
<a href="#">C02527</a>	Motor mounting direction
<a href="#">C02550/2</a>	Speed setpoint interpolation
<a href="#">C02550/3</a>	Torque setpoint interpolation
<a href="#">C02559</a>	Internal torque limit

Greyed out = display parameter

#### 11.10.3.1 Setpoint interpolation

When the setpoint interpolation is activated, the motor control creates intermediate values to "smoothly" follow the speed and/or torque setpoints which may be transferred from a slower task.

- [C02550/2](#) = "1": The motor control follows the speed setpoint in interpolated steps.
- [C02550/3](#) = "1": The motor control follows the torque setpoint in interpolated steps.

#### 11.10.3.2 Inversion of the direction of rotation

Depending on the motor mounting position, if required, the direction of rotation can be inverted:

- [C02527](#) = "0": Clockwise rotating motor ≡ positive machine direction.
- [C02527](#) = "1": Counter-clockwise rotating motor ≡ positive machine direction.

### 11.10.4 Activating setpoint interface

#### Prerequisites

- The controller is in the "Operation" device state.
- The basic function "Torque follower" is part of the active application.
- No other basic function is active.

#### Activation

To request the control via the basic function, the *TF\_bEnable* enable input in the application must be set to TRUE.

- If no other basic function is active, a change-over to the "Torque follower active" function state is carried out, and the motor control is automatically switched over to torque control with speed limitation. Setpoints can now be defined via the corresponding inputs. ▶ [Signal flow](#)
- A successful change to the function state "Torque follower active" is displayed by a TRUE signal at the *TF\_bEnabled* status output.



#### Stop!

The basic function does not take over the control of the drive from the current speed, but immediately with the setpoint defined, which may cause a jerk!

#### Deactivation

When the *TF\_bEnable* enable input is reset to FALSE, the setpoint inputs are inhibited. If the drive is not at standstill, it is braked to standstill within the deceleration time set for stop unless another basic function takes over the control of the drive.

- The status output *TF\_bEnabled* is reset to FALSE and a change-over from the active "Torque follower active" function state via the "Drive is stopped" function state back to the basic state "Drive at standstill" is carried out.

# 11 Basic drive functions

## 11.11 Limiter

### 11.11 Limiter

The basic function "Limiter" monitors the travel range limits via limit switches and parameterised software limit positions and can lead the drive to defined limit ranges when being requested accordingly by the safety module.



#### Danger!

The safety is exclusively ensured by the safety module!

When the request for the safety function is cancelled, the drive can restarts automatically.

Ensure by external measures that the drive only starts after a confirmation (EN 60204).



#### Note!

In order to make it possible for the basic function "Limiter" to lead the drive to the limit ranges defined **after a corresponding request by the safety module**, before the limits set for the safety module have been reached and it shuts down the drive, the limits for the basic function "Limiter" have to be set lower than the limits of the safety module!

See also: [Safety engineering \(📖 369\)](#)

#### 11.11.1 Internal interfaces | "LS\_Limiter" system block

The **LS\_Limiter** system block provides the internal interfaces for the basic function "Limiter" in the function block editor.

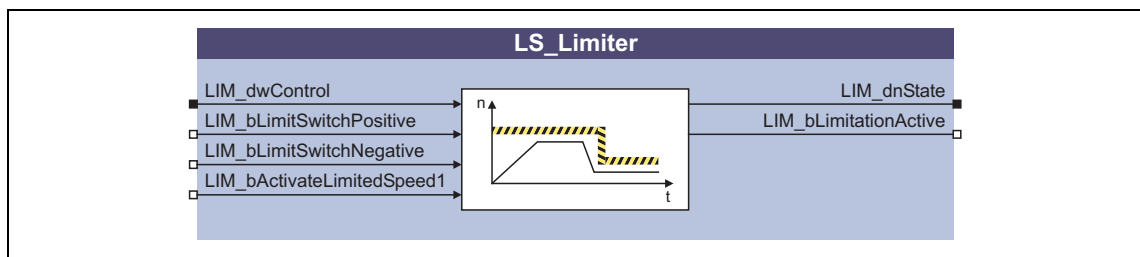

#### Note!

Ensure that the system block is called in a cyclic application task.

Basically, projects which only contain an unsolicited task and no cyclic task are not permissible!

## Inputs

Identifier DIS code   data type	Information/possible settings
LIM_dwControl <a href="#">C02717</a>   DWORD	Interface to the safety module (bit coded) <ul style="list-style-type: none"> <li>• For a simple connection of the safety module to the application, the transmission of the currently valid safety requirement(s) is effected via this bit coded control signal.</li> <li>• It is also possible to make several requirements at the same time via the control signal, e.g. manual jog with limited increment and limited speed 2.</li> <li>• Bits not listed are reserved for future extensions!</li> </ul>
Bit 0	Switched-off torque: request controller inhibit. <ul style="list-style-type: none"> <li>• This bit is no longer supported by the control signal of the <b>LS_SafetyModuleInterface</b> system block.</li> </ul>
Bit 1	Stop 1: request quick stop with subsequent controller inhibit.
Bit 2	Stop 2: request quick stop. <ul style="list-style-type: none"> <li>• If the automatic brake operation is activated, the brake remains open at standstill.</li> </ul>
Bit 3	Request limited speed 1. <ul style="list-style-type: none"> <li>• Change of the traversing profile according to the parameters set for the limited speed 1 (<a href="#">C02708/1</a>, <a href="#">C02710/1</a>, <a href="#">C02711/1</a>).</li> <li>• Only effective for the basic functions "Manual jog", "Homing" and "Positioning".</li> </ul>
Bit 4	Request limited speed 2. <ul style="list-style-type: none"> <li>• Change of the traversing profile according to the parameters set for the limited speed 2 (<a href="#">C02708/2</a>, <a href="#">C02710/2</a>, <a href="#">C02711/2</a>).</li> <li>• Only effective for the basic functions "Manual jog", "Homing" and "Positioning".</li> </ul>
Bit 5	Request limited speed 3. <ul style="list-style-type: none"> <li>• Change of the traversing profile according to the parameters set for the limited speed 3 (<a href="#">C02708/3</a>, <a href="#">C02710/3</a>, <a href="#">C02711/3</a>).</li> <li>• Only effective for the basic functions "Manual jog", "Homing" and "Positioning".</li> </ul>
Bit 6	Request limited speed 4. <ul style="list-style-type: none"> <li>• Change of the traversing profile according to the parameters set for the limited speed 4 (<a href="#">C02708/4</a>, <a href="#">C02710/4</a>, <a href="#">C02711/4</a>).</li> <li>• Only effective for the basic functions "Manual jog", "Homing" and "Positioning".</li> </ul>
Bit 7	Only permit positive direction of rotation. <ul style="list-style-type: none"> <li>• Only effective for the basic functions "Manual jog", "Homing" and "Positioning".</li> </ul>
Bit 8	Only permit negative direction of rotation. <ul style="list-style-type: none"> <li>• Only effective for the basic functions "Manual jog", "Homing" and "Positioning".</li> </ul>
Bit 10	Limited increment <ul style="list-style-type: none"> <li>• Activate maximum distance set in <a href="#">C02713</a> as limited increment for the basic function "Manual jog".</li> </ul>
Bit 12	Defined limit positions <ul style="list-style-type: none"> <li>• Activate software limit positions set in <a href="#">C02701/1</a> and <a href="#">C02701/2</a>.</li> </ul>

Identifier DIS code   data type	Information/possible settings	
LIM_bLimitSwitchPositive <a href="#">C02719/1</a>   BOOL	Input for positive travel range limit switch	
	TRUE	Limit switch is activated.
LIM_bLimitSwitchNegative <a href="#">C02719/2</a>   BOOL	Input for negative travel range limit switch	
	TRUE	Limit switch is activated.
LIM_bActivateLimitedSpeed 1 <a href="#">C02719/3</a>   BOOL	Request limited speed 1 • If a setpoint follower is active, no limitation takes place, but an exceeding of the limit values is displayed via the output <i>LIM_dnState</i> .	
	TRUE	Request limited speed 1.

## Outputs

Identifier DIS code   data type	Value/meaning																																						
LIM_dnState <a href="#">C02718</a>   DINT	Status word (bit coded) • Bits which are not listed are not assigned with a status (always "0"). <table border="1" data-bbox="608 456 1441 1664"> <tr> <td data-bbox="608 456 754 546">Bit 0</td> <td data-bbox="759 456 1441 546">Controller inhibit is initiated. (Safe torque off is requested; bit 0 of the <i>LIM_dwControl</i> control signal is set to "1".)</td> </tr> <tr> <td data-bbox="608 553 754 642">Bit 1</td> <td data-bbox="759 553 1441 642">Quick stop is initiated. (Safe stop 1 is requested; bit 1 of the <i>LIM_dwControl</i> control signal is set to "1".)</td> </tr> <tr> <td data-bbox="608 649 754 739">Bit 2</td> <td data-bbox="759 649 1441 739">Quick stop is initiated. (Safe stop 2 is requested; bit 2 of the <i>LIM_dwControl</i> control signal is set to "1".)</td> </tr> <tr> <td data-bbox="608 745 754 835">Bit 3</td> <td data-bbox="759 745 1441 835">Profile change due to speed limitation. (Limited speed 1 is requested; bit 3 of the <i>LIM_dwControl</i> control signal is set to "1".)</td> </tr> <tr> <td data-bbox="608 842 754 931">Bit 4</td> <td data-bbox="759 842 1441 931">Profile change due to speed limitation. (Limited speed 2 is requested; bit 4 of the <i>LIM_dwControl</i> control signal is set to "1".)</td> </tr> <tr> <td data-bbox="608 938 754 1028">Bit 5</td> <td data-bbox="759 938 1441 1028">Profile change due to speed limitation. (Limited speed 3 is requested; bit 5 of the <i>LIM_dwControl</i> control signal is set to "1".)</td> </tr> <tr> <td data-bbox="608 1034 754 1124">Bit 6</td> <td data-bbox="759 1034 1441 1124">Profile change due to speed limitation. (Limited speed 4 is requested; bit 6 of the <i>LIM_dwControl</i> control signal is set to "1".)</td> </tr> <tr> <td data-bbox="608 1131 754 1220">Bit 7</td> <td data-bbox="759 1131 1441 1220">Only positive direction of rotation is permissible. • When the direction of rotation is negative while requesting "Only positive direction of rotation", the drive is braked to standstill.</td> </tr> <tr> <td data-bbox="608 1227 754 1317">Bit 8</td> <td data-bbox="759 1227 1441 1317">Only negative direction of rotation is permissible. • When the direction of rotation is positive while requesting "Only negative direction of rotation", the drive is braked to standstill.</td> </tr> <tr> <td data-bbox="608 1323 754 1357">Bit 10</td> <td data-bbox="759 1323 1441 1357">Increment in manual jog mode is limited.</td> </tr> <tr> <td data-bbox="608 1364 754 1397">Bit 12</td> <td data-bbox="759 1364 1441 1397">Limitation of the set position is active.</td> </tr> <tr> <td data-bbox="608 1404 754 1438">Bit 16</td> <td data-bbox="759 1404 1441 1438">Positive limit switch inhibits travel in positive direction.</td> </tr> <tr> <td data-bbox="608 1444 754 1478">Bit 17</td> <td data-bbox="759 1444 1441 1478">Negative limit switch inhibits travel in negative direction.</td> </tr> <tr> <td data-bbox="608 1485 754 1518">Bit 18</td> <td data-bbox="759 1485 1441 1518">Positive software limit position inhibits travel in positive direction.</td> </tr> <tr> <td data-bbox="608 1525 754 1559">Bit 19</td> <td data-bbox="759 1525 1441 1559">Negative software limit position inhibits travel in negative direction.</td> </tr> <tr> <td data-bbox="608 1565 754 1599">Bit 20</td> <td data-bbox="759 1565 1441 1599">Limitation of speed is active.</td> </tr> <tr> <td data-bbox="608 1606 754 1639">Bit 21</td> <td data-bbox="759 1606 1441 1639">Limitation of acceleration is active.</td> </tr> <tr> <td data-bbox="608 1646 754 1680">Bit 22</td> <td data-bbox="759 1646 1441 1680">Limitation of deceleration is active.</td> </tr> <tr> <td data-bbox="608 1686 754 1720">Bit 23</td> <td data-bbox="759 1686 1441 1720">Limitation of jerk is active (S-ramp time is increased).</td> </tr> </table>	Bit 0	Controller inhibit is initiated. (Safe torque off is requested; bit 0 of the <i>LIM_dwControl</i> control signal is set to "1".)	Bit 1	Quick stop is initiated. (Safe stop 1 is requested; bit 1 of the <i>LIM_dwControl</i> control signal is set to "1".)	Bit 2	Quick stop is initiated. (Safe stop 2 is requested; bit 2 of the <i>LIM_dwControl</i> control signal is set to "1".)	Bit 3	Profile change due to speed limitation. (Limited speed 1 is requested; bit 3 of the <i>LIM_dwControl</i> control signal is set to "1".)	Bit 4	Profile change due to speed limitation. (Limited speed 2 is requested; bit 4 of the <i>LIM_dwControl</i> control signal is set to "1".)	Bit 5	Profile change due to speed limitation. (Limited speed 3 is requested; bit 5 of the <i>LIM_dwControl</i> control signal is set to "1".)	Bit 6	Profile change due to speed limitation. (Limited speed 4 is requested; bit 6 of the <i>LIM_dwControl</i> control signal is set to "1".)	Bit 7	Only positive direction of rotation is permissible. • When the direction of rotation is negative while requesting "Only positive direction of rotation", the drive is braked to standstill.	Bit 8	Only negative direction of rotation is permissible. • When the direction of rotation is positive while requesting "Only negative direction of rotation", the drive is braked to standstill.	Bit 10	Increment in manual jog mode is limited.	Bit 12	Limitation of the set position is active.	Bit 16	Positive limit switch inhibits travel in positive direction.	Bit 17	Negative limit switch inhibits travel in negative direction.	Bit 18	Positive software limit position inhibits travel in positive direction.	Bit 19	Negative software limit position inhibits travel in negative direction.	Bit 20	Limitation of speed is active.	Bit 21	Limitation of acceleration is active.	Bit 22	Limitation of deceleration is active.	Bit 23	Limitation of jerk is active (S-ramp time is increased).
Bit 0	Controller inhibit is initiated. (Safe torque off is requested; bit 0 of the <i>LIM_dwControl</i> control signal is set to "1".)																																						
Bit 1	Quick stop is initiated. (Safe stop 1 is requested; bit 1 of the <i>LIM_dwControl</i> control signal is set to "1".)																																						
Bit 2	Quick stop is initiated. (Safe stop 2 is requested; bit 2 of the <i>LIM_dwControl</i> control signal is set to "1".)																																						
Bit 3	Profile change due to speed limitation. (Limited speed 1 is requested; bit 3 of the <i>LIM_dwControl</i> control signal is set to "1".)																																						
Bit 4	Profile change due to speed limitation. (Limited speed 2 is requested; bit 4 of the <i>LIM_dwControl</i> control signal is set to "1".)																																						
Bit 5	Profile change due to speed limitation. (Limited speed 3 is requested; bit 5 of the <i>LIM_dwControl</i> control signal is set to "1".)																																						
Bit 6	Profile change due to speed limitation. (Limited speed 4 is requested; bit 6 of the <i>LIM_dwControl</i> control signal is set to "1".)																																						
Bit 7	Only positive direction of rotation is permissible. • When the direction of rotation is negative while requesting "Only positive direction of rotation", the drive is braked to standstill.																																						
Bit 8	Only negative direction of rotation is permissible. • When the direction of rotation is positive while requesting "Only negative direction of rotation", the drive is braked to standstill.																																						
Bit 10	Increment in manual jog mode is limited.																																						
Bit 12	Limitation of the set position is active.																																						
Bit 16	Positive limit switch inhibits travel in positive direction.																																						
Bit 17	Negative limit switch inhibits travel in negative direction.																																						
Bit 18	Positive software limit position inhibits travel in positive direction.																																						
Bit 19	Negative software limit position inhibits travel in negative direction.																																						
Bit 20	Limitation of speed is active.																																						
Bit 21	Limitation of acceleration is active.																																						
Bit 22	Limitation of deceleration is active.																																						
Bit 23	Limitation of jerk is active (S-ramp time is increased).																																						
LIM_bLimitationActive <a href="#">C02715</a>   BOOL	Status signal "Limitation is active" (group signal) <table border="1" data-bbox="608 1704 1441 1738"> <tr> <td data-bbox="608 1704 754 1738">TRUE</td> <td data-bbox="759 1704 1441 1738">A limitation is active.</td> </tr> </table>	TRUE	A limitation is active.																																				
TRUE	A limitation is active.																																						

# 11 Basic drive functions

## 11.11 Limiter

---

### 11.11.1.1 Interface to the safety module

For the simple connection of the safety module to the application, the transmission of the currently valid safety requirement(s) is effected in the form of a bit coded control signal via the following interface:

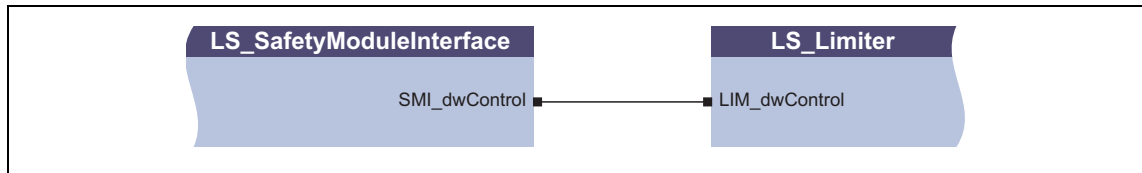

[11-25] Interface to connect the safety module to the basic function "Limiter"

- It is also possible to make several requirements at the same time via the control signal, e.g. manual jog with limited increment and limited speed 2.
- If no safety module is connected, the control signal can also be generated by means of a converter block (FB **L\_DevSMControlEncoder**).

### 11.11.2 Parameter setting

- Parameterisation dialog in »Engineer«: Tab **Application parameters** → Dialog level *Overview* → *All basic functions* → *Limiter*
- Short overview of the parameters for the limiter:

Parameters	Info
<a href="#">C02700</a>	Software limit positions active
<a href="#">C02701/1</a>	Positive software limit position
<a href="#">C02701/2</a>	Negative software limit position
<a href="#">C02702</a>	Limitations effective
<a href="#">C02703</a>	Max. speed
<a href="#">C02704</a>	Max. speed [rpm]
<a href="#">C02705</a>	Max. acceleration
<a href="#">C02706</a>	Min. S-ramp time
<a href="#">C02707</a>	Permissible direction of rotation
<a href="#">C02708/1...4</a>	Limited speed 1 .... 4
<a href="#">C02709/1...4</a>	Limited speed 1 .... 4 (display in [rpm])
<a href="#">C02710/1...4</a>	Dec. limited speed 1 .... 4
<a href="#">C02711/1...4</a>	S-ramp time limited speed 1 .... 4
<a href="#">C02712/1...4</a>	Dec. time limited speed 1 .... 4
<a href="#">C02713</a>	Max. distance manual control
<a href="#">C02714</a>	Max. dist. manual control (display in [increments])
<a href="#">C02715</a>	Limitation active (status display)
<a href="#">C02716/1</a>	Resp. to rotation limitation
<a href="#">C02716/2</a>	Resp. to SW lim. pos. exceeded
<a href="#">C02716/3</a>	Resp. to max. value exceeded
<a href="#">C02720</a>	Observation software limit positions

Greyed out = display parameter



#### Note!

The safety module has its own parameters.

Relevant to the basic function "Limiter" are the parameters of the safety modules for setting "Limited direction of rotation", "Speed with time limit" and "Limited increment (position)".

However, several other parameters of the safety module have no significance for the basic function "Limiter", e. g. the parameters for the configuration of the inputs of the safety module.



### 11.11.2.1 Software limit positions

The parameterisable limit positions serve to limit the traversing range by the software.



#### Note!

Software limit positions are only evaluated and monitored if the drive knows the home position and the software limit positions are active ([C02700](#) = "1").

- When the traversing range is limited ([C02528](#) = "1") and the software limit positions are not active, the range is limited by the software to the internal value range that can be maximally displayed ( $\pm 2^{31}$  increments).
- For the "Modulo" traversing range ([C02528](#) = "2") the software limit positions are generally not effective.
- If the error response that can be set in [C02716/2](#) is deactivated or is only set to "Warning" or "Information", the software limit positions are not effective in an active manner for the basic functions "[Speed follower](#)", "[Torque follower](#)", and "[Position follower](#)"!
- After the software limit positions have been exceeded, it must be ensured before acknowledging a pending error that the setpoint applied to the SB `LS_PositionFollower` is not beyond the software limit positions.

From software version V4.0 onwards, the triggering behaviour of the software limit position monitoring can be parameterised in [C02720](#).

- If you want to maintain the device behaviour known from the previous versions, select "1: Based on set and actual value" in [C02720](#).

▶ [Triggering behaviour of software limit position monitoring](#) (□ 514)

- The positive software limit position is set in [C02701/1](#), and the negative software limit position is set in [C02701/2](#).
- If the software limit positions are active, travelling commands that would result in exiting from the permissible travel range can no longer be executed:

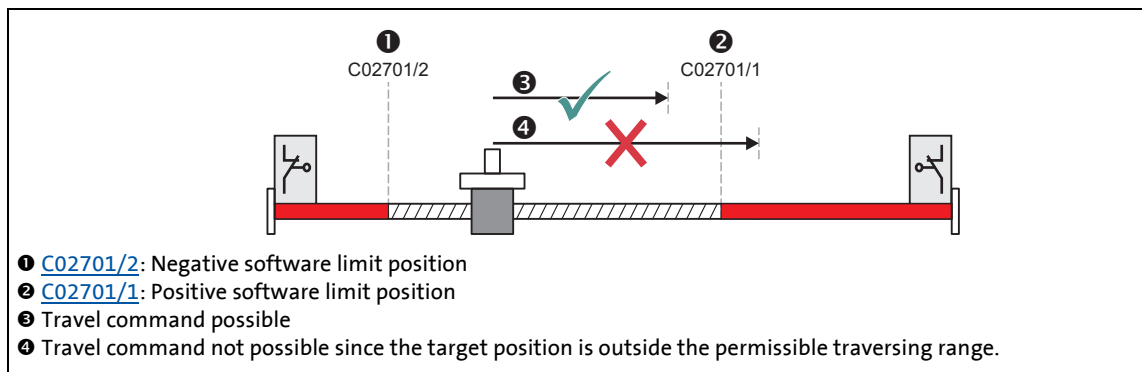

[11-26] Example: Traversing range limitation by means of software limit positions

# 11 Basic drive functions

## 11.11 Limiter

- If the drive is already outside the permissible travel range and the software limit positions have been activated, only travel commands that result in the drive moving back into the permissible travel range can be executed:

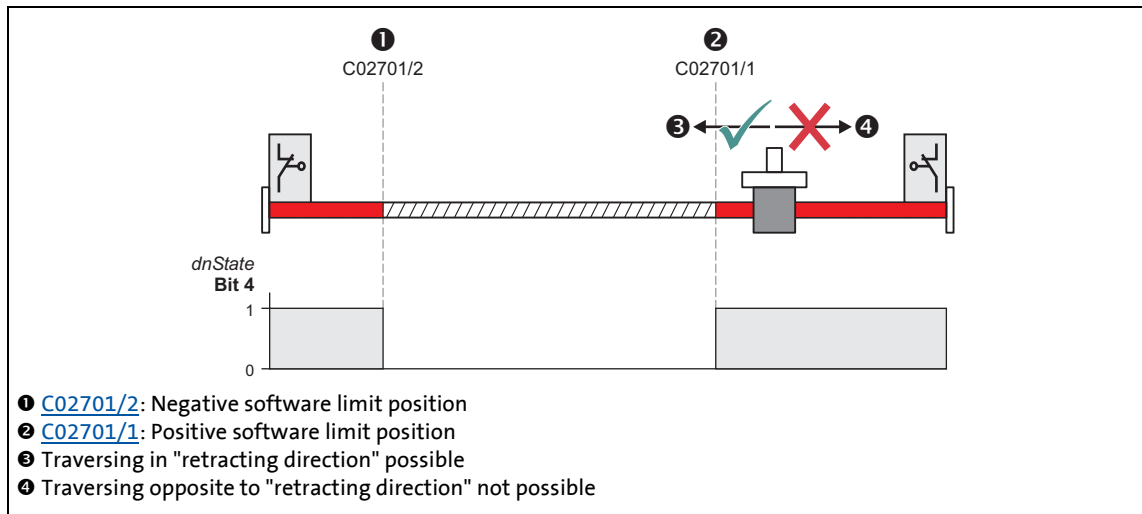

[11-27] Example: Permissible traversing direction if software limit positions active

- If the software limit positions are active and a software limit position is passed ("overtravel"):
  - The error response "quick stop by trouble" is carried out in the Lenze setting, i.e. the drive is braked to standstill within the deceleration time set for the quick stop function irrespective of the setpoint selection. The error response can be parameterised in [C02716/2](#).
  - The fault message "Pos. SW limit switch overtravelled" or "Neg. SW limit overtravelled" is entered in the logbook of the controller.
  - A corresponding status is output via the *LIM\_dnState* output.
  - Depending on the parameterised fault response, the drive cannot traverse until the error has been acknowledged.

See also: [▶ Manual jog to limit position \(📖 410\)](#)

### 11.11.2.2 Triggering behaviour of software limit position monitoring

This function extension is available from software version V4.0!

[C02720](#) can be used to select the triggering behaviour of the software limit position monitoring of non-position-controlled basic functions:

#### Selection "0: Based on set value"

From software version V4.0 onwards, this is the Lenze setting:

- If the basic functions "[Speed follower](#)" and "[Torque follower](#)" are used, the monitoring responds if the drive is outside the software limit positions and a command to travel in the "forbidden" direction is given (depending on the speed setpoint of the application).
- For all other non-position-controlled basic functions, the monitoring does not respond if a software limit position is exceeded.

#### Selection "1: Based on set and actual value"

This selection corresponds to the behaviour known from the previous versions (software versions < V4.0):

- For all non-position-controlled basic functions, the monitoring responds if the actual position exceeds a software limit position.
  - The monitoring also responds in the function states "Controller not ready" and "Error". This may cause the monitoring to trigger permanently if the drive traverses to a software limit position and controller inhibit is set subsequently because the actual position slightly changes around the software limit position.
- If the basic functions "[Speed follower](#)" and "[Torque follower](#)" are used, the monitoring also responds if the drive is outside the software limit positions and a command to travel in the "forbidden" direction is given (depending on the speed setpoint of the application).



#### Note!

If the position-controlled basic functions "[Manual jog](#)", "[Positioning](#)" and "[Position follower](#)" are used, the monitoring responds independently of the triggering behaviour parameterised in [C02720](#) if one of the following cases occurs:

- The setpoint position exceeds a software limit position.
- A travel command is given which would cause the drive to leave the permissible travel range.
- The drive is outside the software limit positions and a command to travel in the "forbidden" direction is given.

If the software limit position monitoring is triggered, the error response parameterised in [C02716/2](#) is carried out.

### 11.11.2.3 Hardware limit positions (limit switch)

Monitoring of the travel range limit by means of limit switches is effected via the inputs *LIM\_bLimitSwitchPositive* and *LIM\_bLimitSwitchNegative* of the **LS\_Limiter** SB.

- The two inputs respond to the TRUE state and are to be connected to the corresponding digital inputs to which the limit switches are connected:

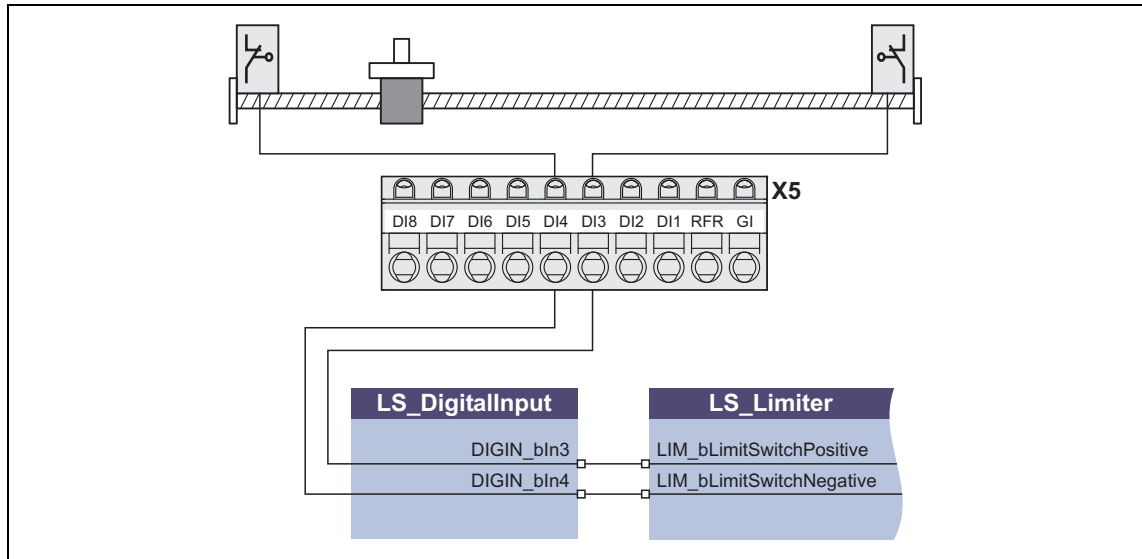

[11-28] Example: Connection of the travel range limit switches to the digital inputs DI3 & DI4

- If the limit switches are connected to decentralised terminals, the two inputs *LIM\_bLimitSwitchPositive* and *LIM\_bLimitSwitchNegative* can be connected to the decentralised terminal via a bus system (e. g. system bus).



#### Note!

If the digital inputs used for the connection of the limit switches are to be designed in a fail-safe manner (activation at LOW level), you simply change the terminal polarity of the corresponding digital inputs in [C00114](#).

- If one of the two monitoring inputs is set to TRUE:
  - The error response "quick stop by trouble" is carried out, i.e. the drive is braked to standstill within the deceleration time set for the quick stop function irrespective of the setpoint selection.
  - The fault message "Pos. SW limit switch has tripped" or "Neg. SW limit has tripped" is entered in the logbook of the controller.
  - A corresponding status is output via the *LIM\_dnState* output.
  - The drive can only be traversed again after the error has been acknowledged.



#### Stop!

If a limit switch is approached by means of the basic function [Position follower](#) and by this a fault with the "Quick stop by trouble" response is activated, always a set/actual adjustment of the position has to be carried out before the fault is acknowledged, as otherwise an uncontrolled motor movement may result after the fault is acknowledged!

# 11 Basic drive functions

## 11.11 Limiter

---



### Tip!

An activated limit switch can be retracted using the function "Retracting the limit switch". ▶ [Retracting of an activated limit switch](#) (📖 411)

*See also:* ▶ [Manual jog to limit position](#) (📖 410)

### 11.11.2.4 Limitations

Limit values for the basic functions "[Manual jog](#)", "[Homing](#)" and "[Positioning](#)" can be set via the following parameters:

Parameters	Info
<a href="#">C02703</a>	Max. speed <ul style="list-style-type: none"> <li>• Max. permissible speed that can be driven by the system.</li> <li>• This parameter depends, among other things, on the max. motor speed.</li> </ul>
<a href="#">C02705</a>	Max. acceleration <ul style="list-style-type: none"> <li>• Max. permissible acceleration or deceleration for positioning processes.</li> <li>• This parameter depends, among other things, on the motor torque and moment of inertia of the entire mechanics which is driven during the positioning process.</li> </ul>
<a href="#">C02706</a>	Min. S-ramp time

- The parameters depend on the mechanics (e.g. the tool used).
- Usually the parameters must be changed when a tool is exchanged, e.g. by means of a recipe management of a superimposed control or via an HMI ("*Human Machine Interface*").



#### Note!

In order that the set limit values are effective, "1" must be selected in [C02702](#).

- Irrespective of this setting, basically, the speed setpoint is limited to the motor reference speed ([C00011](#))!

The limitations are not effective for the basic functions "[Speed follower](#)", "[Torque follower](#)" and "[Position follower](#)"!

- In case of these basic functions only speed and acceleration are monitored.
- If the limit values for speed and acceleration are exceeded, the response parameterised in [C02716/3](#) is activated (Lenze setting: no response).
- **Background:** In the case of technology applications which are synchronised via an electrical shaft, the setpoint followers may not be limited, since synchronism would be lost by this. A possible consequence would be a collision of tools.

- If the limit values are switched effectively and a limit value that is set is exceeded:
  - The setpoints of the active basic function ("[Manual jog](#)", "[Homing](#)" or "[Positioning](#)") are changed (limited).
  - The response parameterised in [C02716/3](#) (Lenze setting: "No response") is activated.
  - A corresponding error message is entered into the logbook of the controller.
  - A corresponding status is output via the *LIM\_dnState* output.
  - The display parameter "Limitation active" ([C02715](#)) is set to "1: Activated".

### 11.11.2.5 Permissible direction of rotation

Via [C02707](#), or alternatively via the input *LIM\_dwControl* (generally by the control word of the safety module) the permissible direction of rotation for the basic functions "[Manual jog](#)", "[Homing](#)", and "[Positioning](#)" can be restricted.



#### Note!

The restriction of the permissible direction of rotation is not actively effective for the basic functions "[Speed follower](#)", "[Torque follower](#)" and "[Position follower](#)"!

- Only the response parameterised in [C02716/1](#) is executed.  
(Lenze setting: "No response")
- If the permissible direction of rotation is restricted and a travel command in the inhibited direction of rotation is requested:
  - The movement of the active basic function ("[Manual jog](#)", "[Homing](#)" or "[Positioning](#)") is cancelled.
  - The response parameterised in [C02716/1](#) (Lenze setting: "No response") is activated.
  - The fault message "Pos. direction of rotation was limited" or "Neg. direction of rotation was limited" is entered in the logbook of the controller.
  - A corresponding status is output via the *LIM\_dnState* output.

### 11.11.2.6 Limited speed

"Limited speeds" for the basic functions "[Manual jog](#)", "[Homing](#)" and "[Positioning](#)" can be set via the following parameters:

Parameters	Info
<a href="#">C02708/1...4</a>	Limited speed 1 .... 4
<a href="#">C02710/1...4</a>	Dec. limited speed 1 .... 4
<a href="#">C02711/1...4</a>	S-ramp time limited speed 1 .... 4
<a href="#">C02712/1...4</a>	Dec. time limited speed 1 .... 4



#### Note!

The limited speeds are not effective for the basic functions "[Speed follower](#)", "[Torque follower](#)" and "[Position follower](#)"!

- The request "Limited speed 1 ... 4" is effected via the input *LIM\_dwControl*, generally by the control word of the safety module. If no safety module is available, the control word for the input *LIM\_dwControl* can also be generated by means of an inverter.
- By means of the input *LIM\_bActivateLimitedSpeed1* additionally the request of "Limited speed 1" can be effected, e. g. via a digital input that is connected to this input.
- If a limited speed is requested and the current speed exceeds the limited speed:
  - The setpoints of the active basic function ("[Manual jog](#)", "[Homing](#)" or "[Positioning](#)") are changed (limited).
  - The response parameterised in [C02716/3](#) (Lenze setting: "No response") is activated.
  - The error message "Speed has been limited" is entered into the logbook of the controller.
  - A corresponding status is output via the *LIM\_dnState* output.
  - The display parameter "Limitation active" ([C02715](#)) is set to "1: Activated".

#### Process example: "Manual jog"

1. Manual jog in positive direction is active and the manual speed is greater than the "Limited speed 1" set.
2. Via the control word of the safety module the "Limited speed 1" is requested.
3. The drive is decelerated to the "Limited speed 1" with the deceleration and S-ramp time set for the "Limited speed 1".
4. At the same time, a corresponding status is output via the *LIM\_dnState* output.



### Priorisation of the limited speeds

The following applies to software versions lower than V3.0:

If several limited speeds are requested at the same time, the parameters of the limited speed with the lowest number are used, i.e. the "Limited speed 1" has the highest priority.

The following applies from software version V3.0:

If several limited speeds are requested at the same time, the lowest speed with the greatest deceleration and the lowest S-ramp time is approached from the parameters of the requested limited speeds.

When activating the profile parameter limitations ([C2702](#) = TRUE), observe the following:

- The SLS deceleration is limited to maximally [C2705](#).
- The SLS jerk time can minimally correspond to the value of the minimum S-ramp ([C2706](#)).

### 11.11.2.7 Limited increment for manual jog

Via [C02713](#) the maximum permissible distance (limited increment) for the basic function "[Manual jog](#)" can be set.

- The request "Limited increment" is effected via the input *LIM\_dwControl*, generally by the control word of the safety module. If no safety module is available, the control word for the input *LIM\_dwControl* can also be generated by means of an inverter.
- In [C02714](#) the maximum permissible distance in [increments] is displayed.

### 11.12 Brake control

This basic function is used for a wear-free control and monitoring of a motor holding brake which in the simplest case is connected to the optionally available motor brake control module (accessories).

Alternatively, the motor holding brake can be controlled via a digital output and monitored via a digital input.

#### Intended use

Motor holding brakes are used to hold axes in the case of controller inhibit or pulse inhibit and in the "Mains OFF" system state. This is not only important for vertical axes, but for instance also for horizontal axes for which an uncontrolled movement can bring about diverse problems.

Examples:

- Loss of the reference information after mains OFF and further spinning of the drive.
- Collision with other moving machine parts.



#### Danger!

Please bear in mind that the motor holding brake is an important element of the safety concept of the entire machine. Thus maintain this system component with special care!



#### Stop!

Motor holding brakes at Lenze motors are not designed for braking during operation. The increased wear resulting from braking during operation may lead to an early destruction of the motor holding brake!



Please observe the notes in the hardware manual for mounting and electrical installation of the motor holding brake!

**Note!**

For the operation with the motor brake control module:

- For single-axis controllers (Single Drive) the control (release) of the motor holding brake is only possible if both the DC-bus voltage and a 24-V supply voltage are available for the motor brake control!
- For multi-axis controllers (Multi Drive) the motor holding brake can also be released without a DC-bus voltage.

**For the encoderless motor control types (from software version V3.0) the following applies:**

The operation of vertical drives/hoists is

- only supported up to 55 kW by the V/f control!
- not supported by the sensorless vector control!

When the V/f control or sensorless vector control are selected, standstill monitoring is always switched off.

# 11 Basic drive functions

## 11.12 Brake control

### 11.12.1 Internal interfaces | "LS\_Brake" system block

The **LS\_Brake** system block provides the internal interfaces for the basic function "Brake control" in the function block editor.

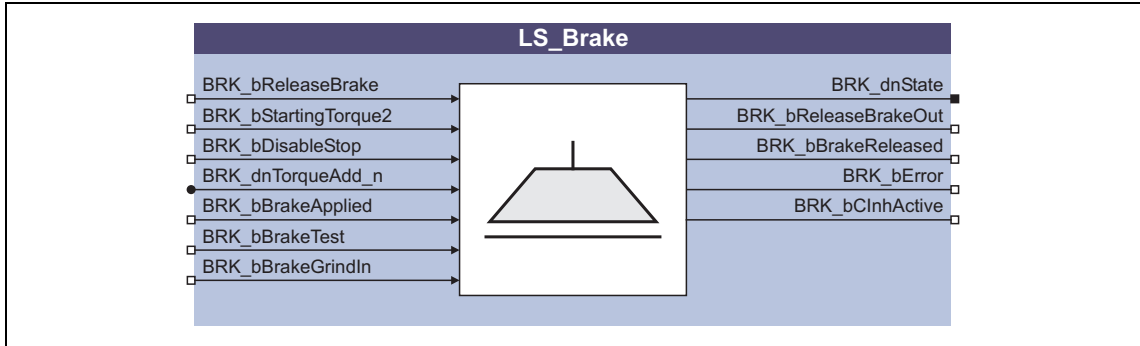

#### Note!

Ensure that the system block is called in a cyclic application task.

Basically, projects which only contain an unsolicited task and no cyclic task are not permissible!

## Inputs

Identifier DIS code   data type	Information/possible settings			
BRK_bReleaseBrake <a href="#">C02609/1</a>   BOOL	Releasing/applying the brake in connection with the selected operating mode			
	<table border="1"> <tr> <td>FALSE</td> <td>Apply brake. • During automatic operation, the internal brake logic controls the brake.</td> </tr> <tr> <td>TRUE</td> <td>Release brake. • During automatic operation, the internal brake logic is deactivated and the brake is released. If the brake control has inhibited the controller, this inhibit is deactivated again.</td> </tr> </table>	FALSE	Apply brake. • During automatic operation, the internal brake logic controls the brake.	TRUE
FALSE	Apply brake. • During automatic operation, the internal brake logic controls the brake.			
TRUE	Release brake. • During automatic operation, the internal brake logic is deactivated and the brake is released. If the brake control has inhibited the controller, this inhibit is deactivated again.			
BRK_bStartingTorque2 <a href="#">C02609/2</a>   BOOL	Selection of the torque feedforward control value • For the general use of the parameterisable starting torque as a feedforward control value, the setting <a href="#">C02588</a> = 0 is required. ▶ <a href="#">Torque feedforward control</a> (□ 537)			
	<table border="1"> <tr> <td>FALSE</td> <td>Starting torque 1 (<a href="#">C02586</a>) is active.</td> </tr> <tr> <td>TRUE</td> <td>Starting torque 2 (<a href="#">C02587</a>) is active.</td> </tr> </table>	FALSE	Starting torque 1 ( <a href="#">C02586</a> ) is active.	TRUE
FALSE	Starting torque 1 ( <a href="#">C02586</a> ) is active.			
TRUE	Starting torque 2 ( <a href="#">C02587</a> ) is active.			
BRK_bDisableStop <a href="#">C02609/10</a>   BOOL	Prevent the brake from being applied in automatic operation • By this the drive remains position-controlled in the function states "Quick stop active", "Drive is stopped", and "Drive at standstill". • The input has no effect when the controller is inhibited.			
	<table border="1"> <tr> <td>TRUE</td> <td>The application of the brake in automatic operation is prevented.</td> </tr> </table>	TRUE	The application of the brake in automatic operation is prevented.	
TRUE	The application of the brake in automatic operation is prevented.			
BRK_dnTorqueAdd_n <a href="#">C02608</a>   DINT	Additive torque value in [%] for torque feedforward control during start • 100 % = <a href="#">C00057/2</a> ▶ <a href="#">Torque feedforward control</a> (□ 537) Note: The input is read out if the brake receives a release signal, e.g. when <i>BRK_bReleaseBrake</i> = TRUE.			
BRK_bBrakeApplied <a href="#">C02609/3</a>   BOOL	Input for status detection via switching contacts at the brake • Activation of the input by setting <a href="#">C02583</a> = 1. ▶ <a href="#">Signal configuration</a> (□ 528)			
	<table border="1"> <tr> <td>FALSE</td> <td>Status "Brake is released".</td> </tr> <tr> <td>TRUE</td> <td>Status "Brake is applied".</td> </tr> </table>	FALSE	Status "Brake is released".	TRUE
FALSE	Status "Brake is released".			
TRUE	Status "Brake is applied".			
BRK_bBrakeTest <a href="#">C02609/4</a>   BOOL	Start/abort of the brake test ▶ <a href="#">Carrying out brake test</a> (□ 554)			
	<table border="1"> <tr> <td>TRUE</td> <td>Carry out brake test</td> </tr> <tr> <td>TRUE↯FALSE</td> <td>Abort brake test (deactivate mode).</td> </tr> </table>	TRUE	Carry out brake test	TRUE↯FALSE
TRUE	Carry out brake test			
TRUE↯FALSE	Abort brake test (deactivate mode).			
BRK_bBrakeGrindIn <a href="#">C02609/5</a>   BOOL	Start/abort of the brake grinding process ▶ <a href="#">Grinding the brake</a> (□ 552)			
	<table border="1"> <tr> <td>TRUE</td> <td>Brake grinding.</td> </tr> <tr> <td>TRUE↯FALSE</td> <td>Abort grinding process (deactivate mode).</td> </tr> </table>	TRUE	Brake grinding.	TRUE↯FALSE
TRUE	Brake grinding.			
TRUE↯FALSE	Abort grinding process (deactivate mode).			

## Outputs

Identifier DIS code   data type	Value/meaning
BRK_dnState <a href="#">C02607</a>   DINT	Status (bit coded) • Bits which are not listed are not assigned with a status (always "0").
	Bit 1 Brake control is active.
	Bit 4 Motor brake control module is used.
	Bit 8 Brake status (internal status signal).
	Bit 9 Torque feedforward control is active.
	Bit 10 Controller inhibit by brake is active or set.
	Bit 15 Fault is active (collective message).
	Bit 16 State "Grinding the brake".
	Bit 17 State "Brake test".
	Bit 18 State "Direct control".
	Bit 19 State "Automatic control".
	Bit 20 Fault: External feedback.
	Bit 21 Fault: Position drift when brake is applied/checked.
	Bit 22 Error: Monitoring of motor brake control module
	Bit 23 Information: Brake activation via waiting time.
Bit 24 Information: Brake grinding process completed.	
Bit 25 Information: Brake test completed.	
Bit 26 Fault: Feedforward control torque could not be established within one second.	
Bit 27 Information: Current speed has fallen below the threshold for brake activation set in <a href="#">C02581</a> .	
BRK_bReleaseBrakeOut <a href="#">C02609/6</a>   BOOL	Control signal for triggering an external brake/status signal for control state
	FALSE Apply brake.
	TRUE Release brake.
BRK_bBrakeReleased <a href="#">C02609/7</a>   BOOL	Status signal of the brake control considering the closing and opening time of the brake
	FALSE Brake applied (after the brake application time has expired).
	TRUE Brake released (after the brake release time has expired).
BRK_bError <a href="#">C02609/8</a>   BOOL	Status signal "Brake error"
	TRUE An error has been detected.
BRK_bCInhActive <a href="#">C02609/9</a>   BOOL	Status signal "Controller inhibit"
	TRUE Controller inhibit has been set by brake control.

### 11.12.2 Parameter setting



#### Danger!

A faultless brake control function requires a correct setting of the different deceleration times in the following parameters!

If the delay times are set incorrectly, a faulty control of the motor holding brake may be caused!

In the case of the basic functions [Manual job, encoderless](#) (□ 412) and [Pole position identification](#) (□ 575), the number of available operating modes of the holding brake is limited. Please refer to the danger notes in the chapters indicated.

- Parameterisation dialog in »Engineer«: Tab **Application parameters** → Dialog level *Overview* → *All basic functions* → *Brake control*
- Short overview of parameters for brake control:

Parameters	Info
<a href="#">C02580</a>	Brake operating mode
<a href="#">C02581</a>	Threshold - brake activation
<a href="#">C02582</a>	Brake resp. to pulse inhibit
<a href="#">C02583</a>	Status input monitoring
<a href="#">C02585</a>	Brake control polarity
<a href="#">C02586</a>	Starting torque 1
<a href="#">C02587</a>	Starting torque 2
<a href="#">C02588</a>	Source of starting torque
<a href="#">C02589</a>	Brake closing time
<a href="#">C02590</a>	Brake opening time
<a href="#">C02591</a>	Waiting time - status monitoring
<a href="#">C02593</a>	Waiting time - brake activation
<a href="#">C02594</a>	Test torque
<a href="#">C02595</a>	Permissible angle of rotation
<a href="#">C02596</a>	Grinding speed
<a href="#">C02597</a>	Accel./decel. time - grinding
<a href="#">C02598</a>	Grinding ON time
<a href="#">C02599</a>	Grinding OFF time
<a href="#">C02600</a>	Acceleration time feedf. control
<a href="#">C02601</a>	Reference for acceleration time of brake
<a href="#">C02602</a>	Source for feedf. control brake
<a href="#">C02603</a>	Threshold 1 for opening brake
<a href="#">C02604</a>	Threshold 2 for opening brake
<a href="#">C02605/1</a>	Acceleration time - brake test
<a href="#">C02605/2</a>	Duration of constant torque - brake test
<a href="#">C02605/3</a>	Deceleration time - brake test
<a href="#">C02606</a>	Minimum starting torque

# 11 Basic drive functions

## 11.12 Brake control

---

### 11.12.2.1 Operating mode

Various operating modes are available in [C02580](#) for different applications and tasks:

- [Mode 0: Brake control is switched off](#) (📖 542)
- [Mode 1/11: Direct control of the brake](#) (📖 543)
  - Without a specific logic or automatic system, can for instance be used to carry out a simple check on whether the brake switches correctly.
- [Mode 2/12: Automatic control of the brake](#) (📖 544)
  - The normal mode for the control of mech. holding brakes with and without holding torque precontrol.

---

Function extension from software version V3.0:

- [Mode 22: Automatic DC-injection braking](#) (📖 549)
    - DC-injection braking for V/f control and sensorless vector control.
-



# 11 Basic drive functions

## 11.12 Brake control

### 11.12.2.2 Signal configuration

The signal configuration of the control and status signals for the brake logic and monitoring function is executed via the parameters shown in the following signal flows.

#### Direct brake control

This triggering of the holding brake does not need the motor brake control module:

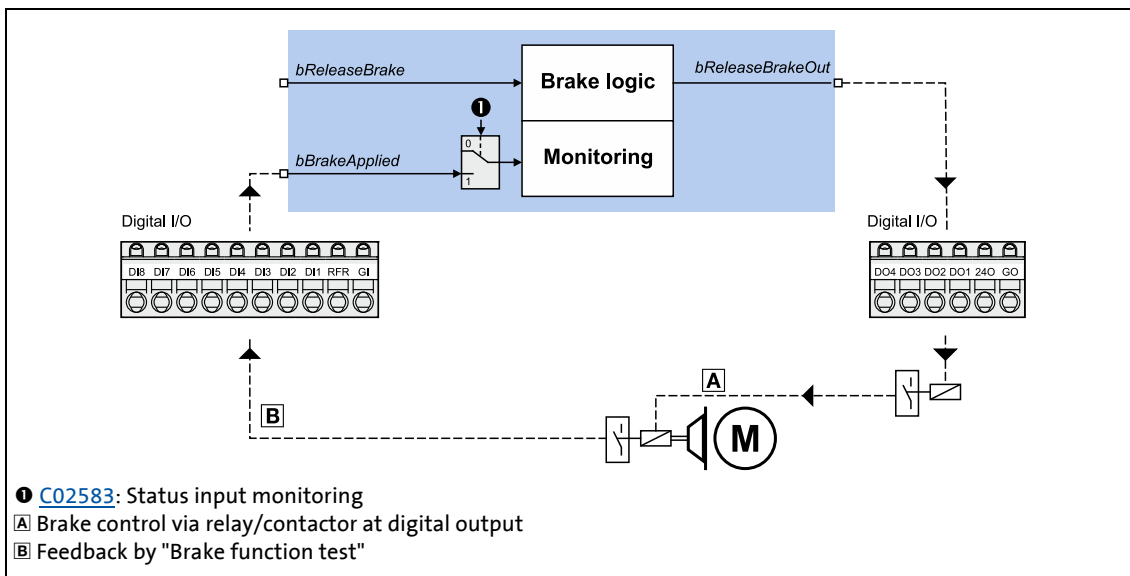

[11-29] Direct control of the motor holding brake

### Triggering the brake via the motor brake control module E94AZHA0051

The design of the motor brake control module E94AZHA0051 enables the external control of the holding brake via an additional 3-pole terminal (X121).

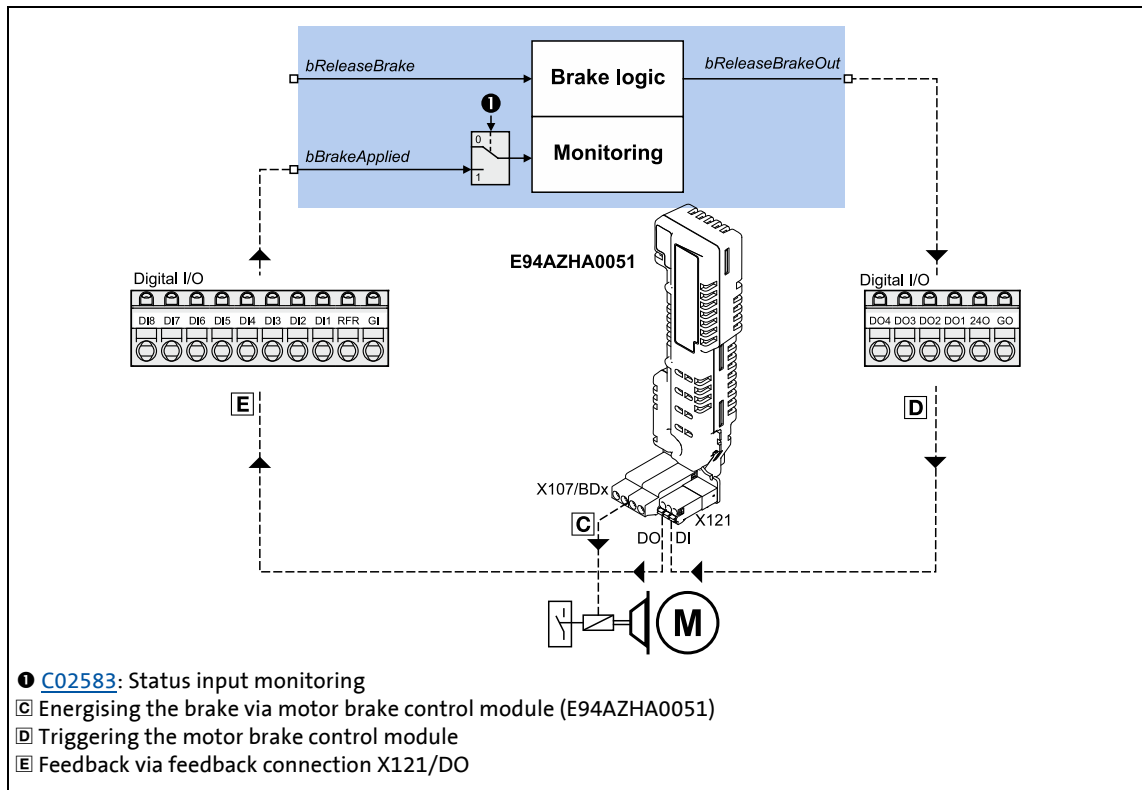

[11-30] Signal configuration of the control and status signal with the motor brake control module E94AZHA0051

### Triggering the brake via the motor brake control module E94AZHX0051

The motor brake control module E94AZHX0051 does **not** include an additional 3-pole terminal for the external control of the holding brake.

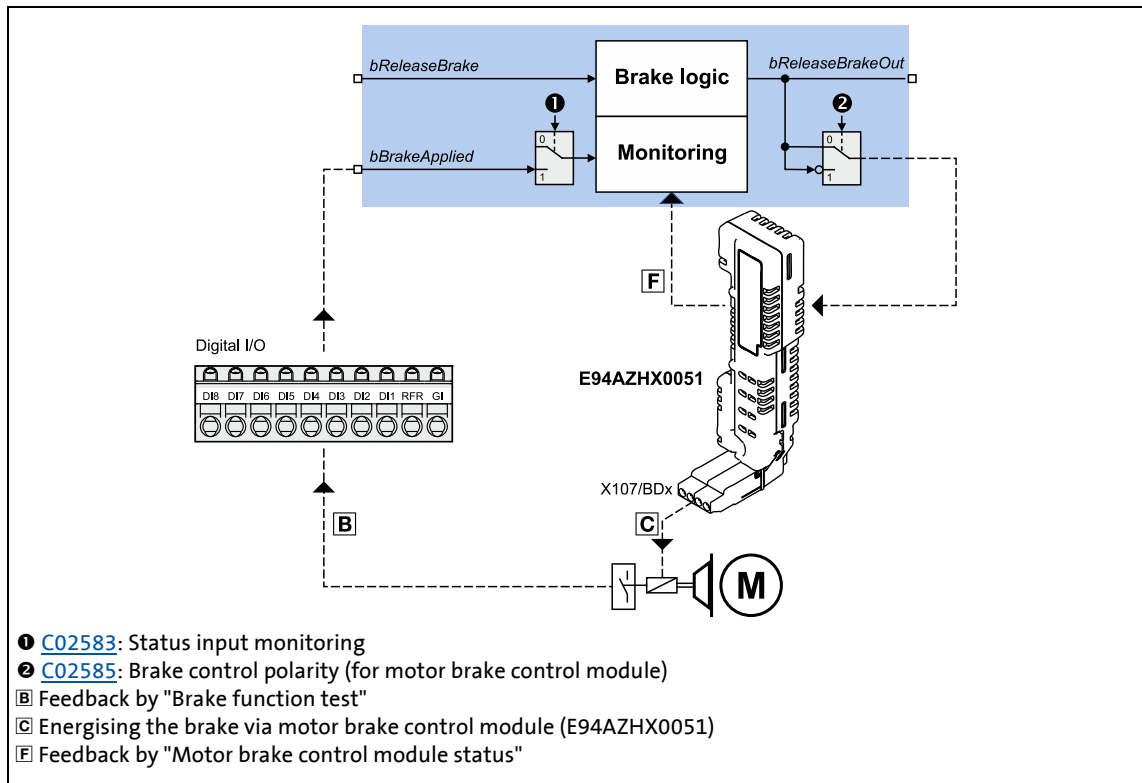

[11-31] Signal configuration of the control and status signal with the motor brake control module E84AZHX0051



### Note!

If an electrically holding (self-releasing) motor holding brake is to be controlled instead of an electrically releasing (self-holding) motor holding brake, the corresponding control and status signals must be inverted!



Please observe the notes in the hardware manual for mounting and electrical installation of the motor holding brake!

### Status monitoring by "Motor brake control module status"

(See signal path [E](#) in fig. [\[11-30\]](#))

- Indirect status detection of the brake function.
- Monitoring of the motor brake control module and the electrical brake circuit.

### Status monitoring by "Brake function test"

(See signal path [B](#) in fig. [\[11-29\]](#) or [\[11-31\]](#))

- Direct function test of the complete brake circuit by microswitches at the brake.
- Wear control of the brake rotor.

### 11.12.2.3 Standstill monitoring

After the brake closing time and the waiting time for the status monitoring have elapsed, the standstill monitoring becomes active, i. e. the holding position is noted and compared to the permissible angle of rotation set in [C02595](#) (Lenze setting: 5°) when the brake is applied.

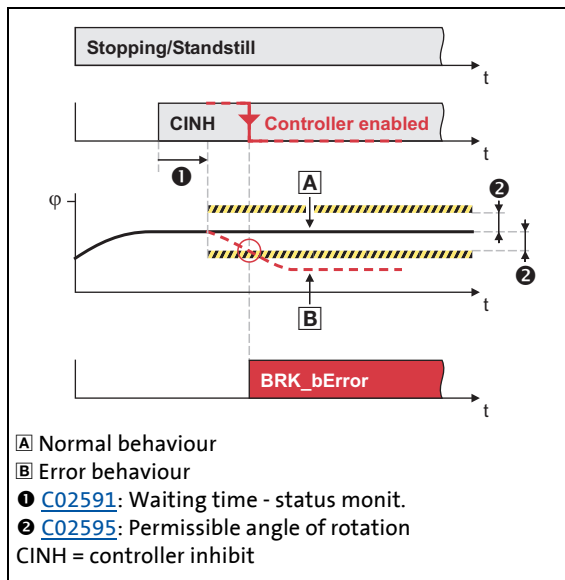

[11-32] Automatic monitoring of the holding position

- If the stop position of the motor axis has changed by more than the permissible angle of rotation set in [C02595](#), although the brake is engaged:
  - The error message "Motor brake: Angular drift with closed brake too high" is entered into the logbook.
  - "Quick stop by trouble" is activated as error response to avoid a further rotation/acceleration of the drive.
  - The error output *BRK\_bError* is set to TRUE for one task cycle.
  - The status "position drift when brake is applied" is displayed at the *BRK\_dnState* status output via bit 21 for one task cycle.



### Note!

The standstill monitoring can be switched off by the setting [C02595](#) = "0".

**For the encoderless motor control types (from software version V3.0) the following applies:**

If the V/f control or the sensorless vector control is selected, the standstill monitoring is generally switched off, irrespective of the setting in [C02595](#).

### 11.12.2.4 Speed watchdog

#### Brake activation through $N < N_{min}$

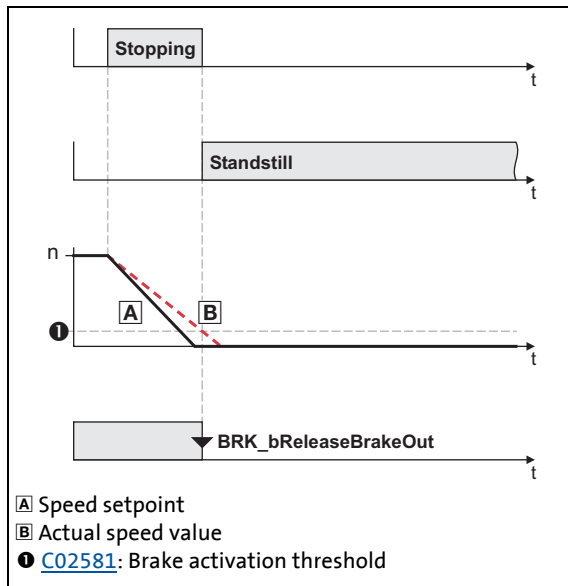

[11-33] Process of brake activation through  $N < N_{min}$



#### Tip!

The value in [C02581](#) should be set to approx. 5 ... 20 % of the maximum speed to minimise the wear of the brake and also provide for an optimum braking behaviour by a low grinding of the brake.

- If the motor speed falls below the threshold for brake activation set in [C02581](#), the function "Close brake" is activated in the automatic operation (mode 2/12).
- Here only the absolute value of the motor speed is considered, the direction of rotation remains unconsidered.
- In manual operation (mode 1/11) [C02581](#) has no function.

### Brake activation through time-out

If a waiting time for the brake activation  $> 0$  s is set in [C02593](#), the time monitoring is active, i. e. the brake at the latest is activated for application after the waiting time has elapsed, even if the actual speed value is still above the threshold for the brake activation set in [C02581](#).



#### Note!

In the Lenze setting the time monitoring is not active ([C02593](#) = "0 s").

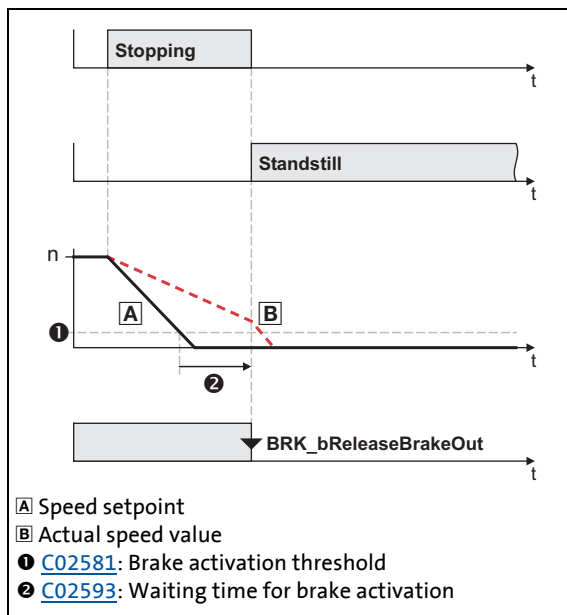

[11-34] Process of brake activation through time-out

- The waiting time starts to elapse if the speed setpoint has reached the threshold for the brake activation.
- If the speed setpoint is still above the threshold after the waiting time has elapsed:
  - The brake is automatically triggered to close in automatic operation (mode 2/12).
  - The "brake activation via waiting time" status is displayed at the *BRK\_dnState* status output via bit 23.
  - The information "Motor brake: Automatically activated after waiting time has elapsed" is entered in the logbook.

### 11.12.2.5 Braking time characteristics

#### Application and release time



#### Danger!

A wrong setting of the closing and opening time can cause a wrong activation of the motor holding brake!

- When the closing time is set too low, the controller is inhibited and the drive gets torqueless before the motor holding brake is closed completely.

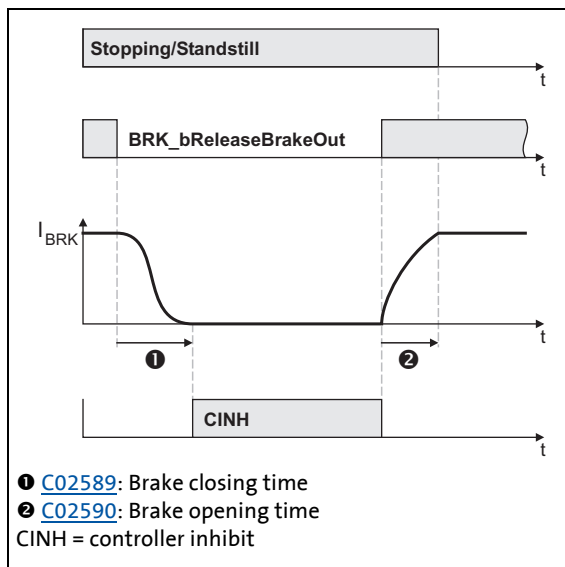

- Every mechanical motor holding brake has a construction-conditioned application and opening time which has to be taken into consideration by the brake control and which for this purpose has to be set in [C02589](#) and in [C02590](#).
- The information on the application and opening time of a Lenze-motor holding brake can be found in the corresponding Operating Instructions in the chapter "Technical data".
- If the application and release times are too long, this is uncritical in respect of safety but leads to unnecessarily long delays during cyclical braking processes.

[11-35] Definition of the application and release time with the example of the PM brake



#### Tip!

The application and release times do not only vary between the brake types but also depend on the basic conditions in the plant:

- Parameters of the hardware (cable length, temperature, level of supply voltage etc.)
- Contact elements used (motor brake control module or contactor at the digital output)
- Type of overvoltage limitation/suppressor circuit

For optimisation purposes, detect in individual cases the response times by measurement.

### Motor magnetising time (only with asynchronous motor)

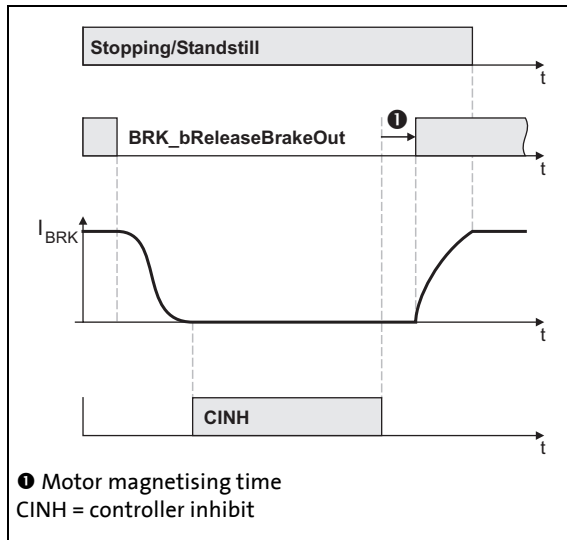

- When an asynchronous motor is used, first the magnetic field required for the holding torque is created (which is already available when a synchronous motor is used) after the controller inhibit is deactivated.
- The brake is only released if the actual torque has reached 90 % of the feedforward control torque.

[11-36] Considering the motor magnetising time taking the PM brake as an example



### Waiting time for status monitoring

Every time the brake status changes, the waiting time set in [C02591](#) is awaited after the brake opening or brake closing time has elapsed, before the monitoring of the motor brake control module and the status input *BRK\_bBrakeApplied* (if activated via [C02583](#)) and the standstill monitoring function are switched active again.

- During the "Closing the brake" process, a mechanical contact must signal the "brake closed" state after the waiting time has elapsed.
- During the "Releasing the brake" process, a mechanical contact must signal the "brake released" state after the waiting time has elapsed.



#### Tip!

The additional waiting time is based on the fact that during the state change of the brake also state changes with regard to the monitored signals within the brake logic can occur, e. g. by bouncing the microswitch on the brake, or activation of the short circuit threshold within the motor brake control module due to discharge current peaks when the brake voltage is switched on. These state changes result in the activation of the monitoring function, although no stationary fault is pending.

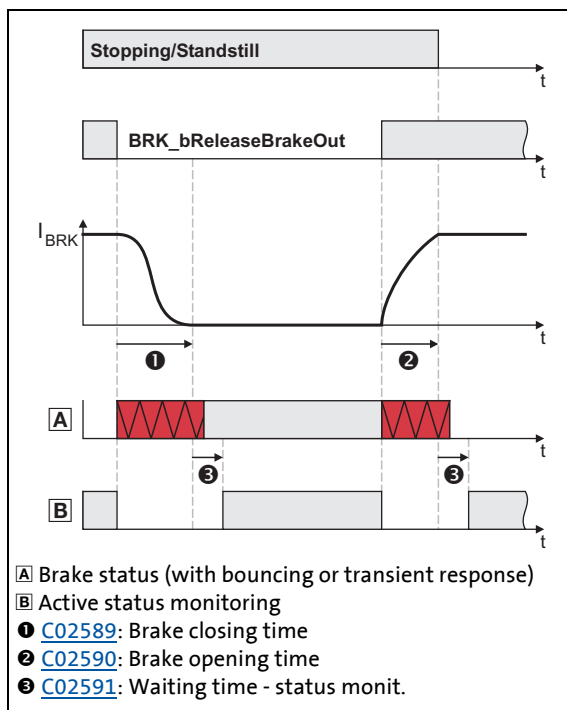

[11-37] Definition of the waiting time for status monitoring

- The waiting time in [C02591](#) must be set so that bouncing of a feedback contact and the transient response of the brake current monitoring will be suppressed completely.
- If no corresponding feedback takes place after the waiting time has elapsed:
  - The error output *BRK\_bError* is set to TRUE until the next trigger attempt starts.
  - The error response "Quick stop by trouble" is activated.
  - The error message "Brake status error" is entered into the logbook.

### 11.12.2.6 Torque feedforward control

In automatic operation (mode 2/12) the brake control offers the possibility of precontrolling the required torque of the drive when the brake is released.



#### Note!

The torque is precontrolled for one second. During this time, the actual torque must have reached 90 % of the set torque, otherwise a fault is tripped!

The torque feedforward control is also supported for the V/f control (from software version V3.0).

Via [C02588](#) first the basic selection on whether a parameterised starting torque or the torque memorised during the last application process is to be used for the feedforward control.

With this setting, [C02606](#) serves to define an additional torque which is to be used for feedforward control. This is for instance reasonable for hoist drives, in order to avoid, for example, that, due to stalling, a counteracting standstill torque is saved.

#### Feedforward control with parameterised starting torque

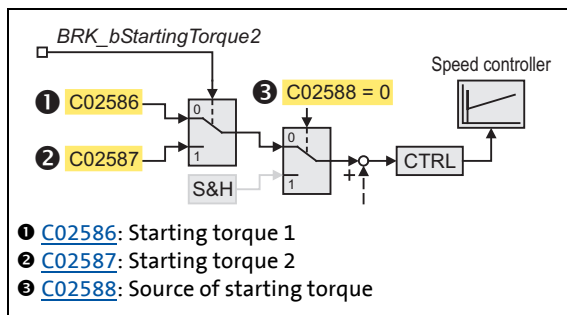

[11-38] Feedforward control with parameterised starting torque

- When [C02588](#) = 0, a change-over between two starting torques is possible via input *BRK\_bStartingTorque2*:
  - *BRK\_bStartingTorque2* = FALSE: Starting torque 1 ([C02586](#)) is used.
  - *BRK\_bStartingTorque2* = TRUE: Starting torque 2 ([C02587](#)) is used.

#### Application example:

A hoist drive is to be operated with different loads. Unfortunately we do not know when the load is available, but the starting direction (lifting or lowering) is known.

- In a no-load condition, the hoist drive needs a torque of 10 Nm. For holding the maximum load it needs a torque of 50 Nm.
- The change-over between lifting and lowering at start-up is done via the input *BRK\_bStartingTorque2*.

# 11 Basic drive functions

## 11.12 Brake control

- To ensure the correct direction at start-up, the speed controller is loaded with the following starting torques:

	Lifting	Lowering
Starting torque:	<a href="#">C02586</a> = 50 Nm	<a href="#">C02587</a> = 10 Nm

- This results in the following behaviour depending on load and direction:

	Lifting	Lowering
Behaviour at max. load:	Optimum behaviour	Start-up a bit fast, but correct direction (non-critical).
Behaviour without load:	Start-up a bit fast, but correct direction (non-critical).	Optimum behaviour

### Feedforward control with memorised torque

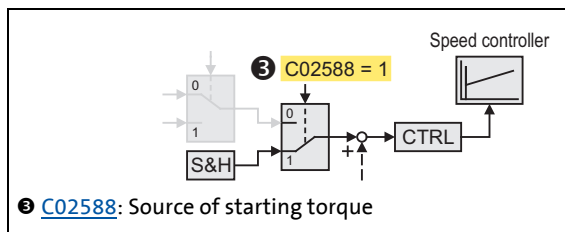

- When [C02588](#) = 1, the starting torque is the setpoint which has been automatically memorised during the last closing process (falling below the speed threshold set in [C02581](#)).

[11-39] Feedforward control with parameterised starting torque



### Note!

The greater the threshold for the brake activation set in [C02581](#), the greater the dynamic portion (e. g. the speed-dependent friction torque) in the memorised torque.

For the specific case that the load is altered while the motor holding brake is closed, a correction value for the torque feedforward control can be defined via the input *BRK\_dnTorqueAdd\_n* that is added to the memorised torque.

### Further torque feedforward control options

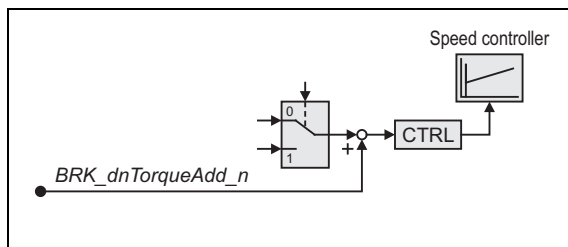

[11-40] Feedforward control with parameterised starting torque

- Via the input *BRK\_dnTorqueAdd\_n* an additional feedforward control value can be defined.

Note:

The input is read out if the brake receives a release signal, e.g. when *BRK\_bReleaseBrake* = TRUE.

#### Application example:

In the case of a hoist drive, the load is always known. For an optimum behaviour a torque proportional to the load and additionally 10 Nm as a constant feedforward control value should be loaded into the speed controller.

- As a constant feedforward control value the starting torque 1 is used ([C02586](#) = "10 Nm", [C02588](#) = "0", and *BRK\_bStartingTorque2* = FALSE).
- Via the input *BRK\_dnTorqueAdd\_n* the torque is specified proportional to the load.

### 11.12.2.7 Torque feedforward control via ramp function

This function extension is available from software version V3.0!

The brake control additionally offers the possibility of establishing the required torque of the drive when the brake is released via a parameterisable ramp function.

#### Recruitments

1. Go to [C02600](#) and set the acceleration time for the feedforward control.
2. Go to [C02601](#) and select the reference for the acceleration time:
  - Selection "0: Motor reference value":  
The acceleration time refers to the generation of the motor reference torque ([C00057/2](#)), i.e. the acceleration is constant.
  - Selection "1: Starting current value":  
The acceleration time refers to the torque requested, i. e. the acceleration time is constant.

#### Procedure

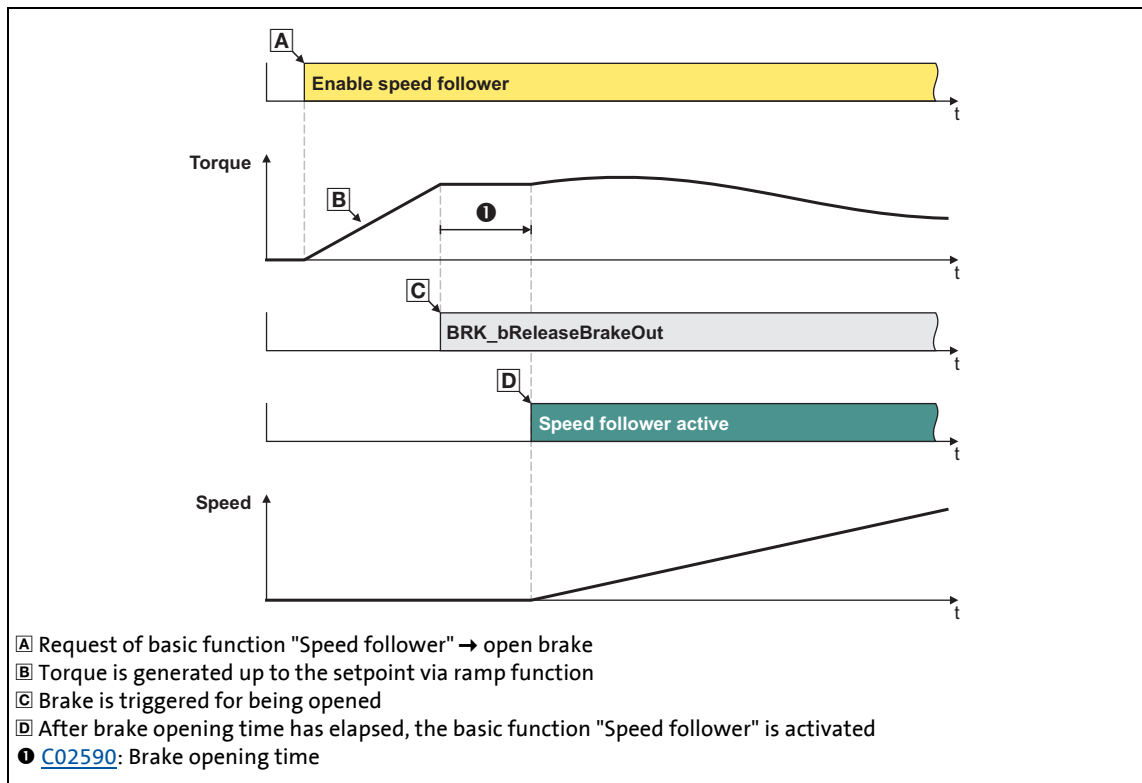

[11-41] Sequence of torque feedforward control via ramp function

### 11.12.2.8 Speed feedforward control via ramp function for V/f control

This function extension is available from software version V3.0!

For the V/f control there is the possibility of carrying out a feedforward control by means of a speed which is generated via a parameterisable ramp.



#### Note!

The operation of vertical drives/hoists is only supported up to 55 kW by the V/f control!

#### Settings:

1. Go to [C02602](#) and set the selection "1: Speed" as source for the feedforward control.
2. Go to [C02603](#) to set the speed threshold from which on the brake is to be opened.
  - [C02604](#) can be used to parameterise a second speed threshold which can be activated by setting *BRK\_bStartingTorque2* to TRUE.
3. Go to [C02600](#) and set the acceleration time for the feedforward control.
4. Go to [C02601](#) and set the reference for the acceleration time (0: Motor reference value, 1: Starting current value).

### 11.12.3 Mode 0: Brake control is switched off

If the mode 0 is selected in [C02580](#), the brake control is switched off.

- If a motor brake control module is available, it will not be triggered.
- The brake monitoring function is not active.
- A potential fault reported by the brake control is reset automatically.
- The output signals of the system block LS\_Brake are reset:
  - *BRK\_dnState* = 0
  - *BRK\_bReleaseBrakeOut* = FALSE
  - *BRK\_bBrakeReleased* = FALSE
  - *BRK\_bError* = FALSE



#### Note!

In the Lenze setting, the mode 0 is preset to get into a safe state after the mains is switched on.

### 11.12.4 Mode 1/11: Direct control of the brake

If the mode 1 or 11 has been selected in [C02580](#), the brake is directly controlled via the input *BRK\_bReleaseBrake*.



#### Tip!

Mode 1/11 can be used to easily check if the brake switches correctly.

- By the selection of the mode it is also defined in which way the brake is to be controlled:
  - Mode 1: Direct brake control via a motor brake control module.
  - Mode 11: Direct brake control via a digital output.



#### Note!

The digital outputs are not suitable for the "direct" control of a motor holding brake!

- The digital output used must be connected to a relay or power contactor which switches the brake supply.
- If a power contactor is used, the response and release time of the contactor contact is also added to the response and release time of the brake.

For the operation with the motor brake control module:

- For single-axis controllers (Single Drive) the control (release) of the motor holding brake is only possible if both the DC-bus voltage and a 24-V supply voltage are available for the motor brake control!
- For multi-axis controllers (Multi Drive) the motor holding brake can also be released without a DC-bus voltage.

- Setting the pulse inhibit or controller inhibit does not influence the output signal.
- After the brake has been activated and the brake closing time has elapsed, the controller inhibit is set automatically by the basic function "brake control".
- For the operation with a motor brake control module (mode 1) the desired polarity for controlling the brake can be set in [C02585](#).



### 11.12.5 Mode 2/12: Automatic control of the brake

If mode 2 or mode 12 is selected in [C02580](#), the brake is controlled automatically, i. e. if another basic function is activated, which results in a traversing of the drive, the brake is automatically opened and operation is enabled. If the corresponding basic function is deactivated again, the drive is stopped via the basic function "[Stop](#)" and the brake is automatically closed again if the speed setpoint and the actual speed value are below the speed threshold set in [C02581](#).



#### Tip!

The 2/12 mode is the usual mode to control the brake.

In this mode, the `BRK_bReleaseBrake` input should be set permanently to FALSE unless a manual release is required.

If `BRK_bReleaseBrake = TRUE`, the brake is released permanently and the automatic control cannot close the brake.

- By the selection of the mode it is also defined in which way the brake is to be controlled:
  - Mode 2: Current monitoring active, brake is automatically controlled via motor brake control module.
  - Mode 12: Current monitoring deactivated, brake is controlled via digital output. If a motor brake control module is installed, this will also be controlled.



#### Note!

The digital outputs are not suitable for the "direct" control of a motor holding brake!

- The digital output used must be connected to a relay or power contactor which switches the brake supply.
- If a power contactor is used, the response and release time of the contactor contact is also added to the response and release time of the brake.

For the operation with the motor brake control module:

- For single-axis controllers (Single Drive) the control (release) of the motor holding brake is only possible if both the DC-bus voltage and a 24-V supply voltage are available for the motor brake control!
- For multi-axis controllers (Multi Drive) the motor holding brake can also be released without a DC-bus voltage.

- The brake is also activated automatically if a quick stop is activated in the drive, e.g. via the basic function "[Quick stop](#)" or as a response to a fault and also in case of a controller inhibit and pulse inhibit. ▶ [Behaviour in case of pulse inhibit](#) (📖 545)
- By setting the input *BRK\_bDisableStop* to TRUE, an application of the brake at standstill or during quick stop can be avoided; by this the drive remains position-controlled.
- After the brake has been activated automatically and the brake closing time has elapsed, the controller inhibit is set automatically by the basic function "brake control".
- For the operation with a motor brake control module (mode 2) the desired polarity for controlling the brake can be set in [C02585](#).

### 11.12.5.1 Behaviour in case of pulse inhibit

In case of pulse inhibit the brake is applied. This occurs according to the parameter setting in [C02582](#) either immediately (default setting) or delayed when the threshold set for brake activation is fallen below, which can be selected to protect the brake if high centrifugal masses occur.



#### Note!

Setting the pulse inhibit results causes the motor to coast down in a load-controlled manner until pulse enable is carried out again.

Pulse inhibit can be set in the enabled controller, e.g. due to a DC overvoltage, DC undervoltage or the "Safe torque off" request.



#### Stop!

Before setting the parameters of [C02582](#) it is important to assess the energy conditions of the machine.

The amount of energy stored in the machine can exceed the permissible switching energy of a motor holding brake at the time of pulse inhibit and can thus destroy the brake when being applied!

#### Activate the brake in any case

When [C02582](#) = "0", the brake is immediately triggered to close to prevent the mechanics from being damaged.

---

### Only activate brake below threshold for brake activation

When [C02582](#) = "1", the brake remains released until the threshold set in [C02581](#) for brake activation has been reached to protect the brake from excessive wear.

- The braking action only takes place due to the friction in the load mechanics.
- Only when the motor speed has reached the threshold for brake activation, the brake will be closed.



#### Stop!

Do not set the threshold for brake activation in [C02581](#) too high to protect the motor holding brake from wear!



#### Note!

**For the encoderless motor control types (from software version V3.0) the following applies:**

If V/f control without encoder or sensorless vector control is selected, there is no speed information for the controller in the case of pulse inhibit, therefore the threshold set in [C02581](#) for the brake activation is not effective in this case.

In order to avoid that the motor holding brake is closed in case of pulse inhibit, a waiting time for the brake activation can be parameterised in [C02593](#). In case of pulse inhibit, the motor holding brake is then only triggered to close after this application time has elapsed. ▶ [Speed watchdog](#) (□ 532)

### 11.12.5.2 Process when brake is released

The following process occurs when a basic function is requested which causes the drive to traverse:

1. The controller inhibit is deactivated.
2. The magnetic field required for the holding torque is created in the motor (is already available when a synchronous machine is used).
3. The feedforward control torque is loaded into the speed controller.
4. If the actual torque has reached 90 % of the feedforward control torque:
  - The output *BRK\_bReleaseBrakeOut* is set to TRUE for releasing the brake.
  - Monitoring of the motor brake control module is deactivated temporarily.
  - Monitoring of the status input is deactivated temporarily (if switched active via [C02583](#)).
  - The brake opening time starts to elapse.
5. After the brake opening time has elapsed:
  - The output *BRK\_bBrakeReleased* is set to TRUE.
  - The requested basic function is enabled.
6. After the additional waiting time set for the status monitoring in [C02591](#) has elapsed:
  - Monitoring of the motor brake control module is active again.
  - Monitoring of the status input is active again (if switched active via [C02583](#)).

### 11.12.5.3 Process when brake is closed

The following process occurs if the enable of the requested basic function for traversing the drive is deactivated again:

1. The drive is brought to standstill via the basic function "[Stop](#)", or, where required, also via the basic function "[Quick stop](#)".
2. When speed setpoint and actual speed value have fallen below the speed threshold set in [C02581](#):
  - The output *BRK\_bReleaseBrakeOut* is set to FALSE for closing the brake.
  - The current torque is saved, so that, if necessary, it can be used for feedforward control during the next start.
  - Monitoring of the motor brake control module is deactivated temporarily.
  - Monitoring of the status input is deactivated temporarily (if switched active via [C02583](#)).
  - The brake application time starts to expire.
3. After the brake closing time has elapsed and the corresponding state change of the status signal:
  - The output *BRK\_bBrakeReleased* is reset to FALSE.
  - Controller inhibit set.
4. After the additional waiting time set for the status monitoring in [C02591](#) has elapsed:
  - Monitoring of the motor brake control module is active again.
  - Monitoring of the status input is active again (if switched active via [C02583](#)).
  - Standstill monitoring is activated. ▶ [Standstill monitoring](#) (□ 531)

### 11.12.6 Mode 22: Automatic DC-injection braking

This function extension is available from software version V3.0!



#### Note!

Automatic DC-injection braking is only possible if V/f control or sensorless vector control is selected as motor control type in [C00006](#)!

If mode 22 has been selected in [C02580](#), DC-injection braking is executed automatically if the current speed setpoint falls below the speed threshold set in [C02581](#).

- The automatic is only effective in the function states "Drive is stopped", "Drive at standstill", "Quick stop active", and "Fault".
- DC-injection braking is executed for the brake closing time set in [C02589](#) with the braking current set in [C00974](#).
- After the brake closing time has elapsed, the controller inhibit is set automatically by the basic function "brake control".



#### Danger!

If the braking current is set too low, or the application time is too short, controller inhibit is set and the drive becomes torqueless before being completely braked to standstill by means of DC-injection braking!

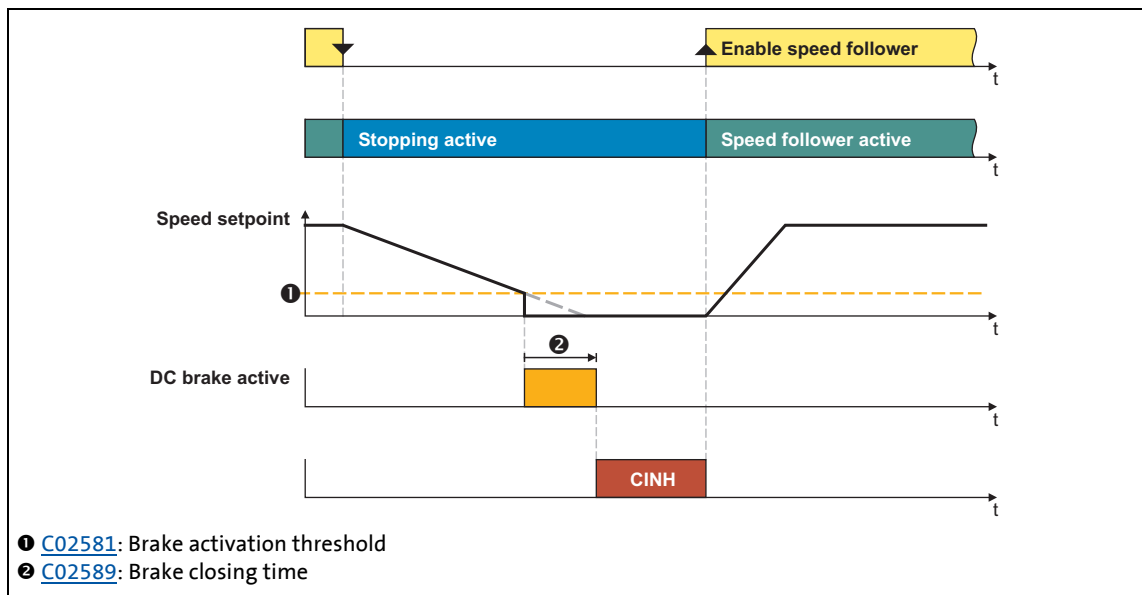

[11-42] Example 1: Speed follower active → stopping active (stopping time > brake closing time) → speed follower active

- If a basic function is requested again before the brake closing time has elapsed, DC-injection braking is interrupted and - if activated in [C00990](#) – the flying restart process is started and the basic function is activated:

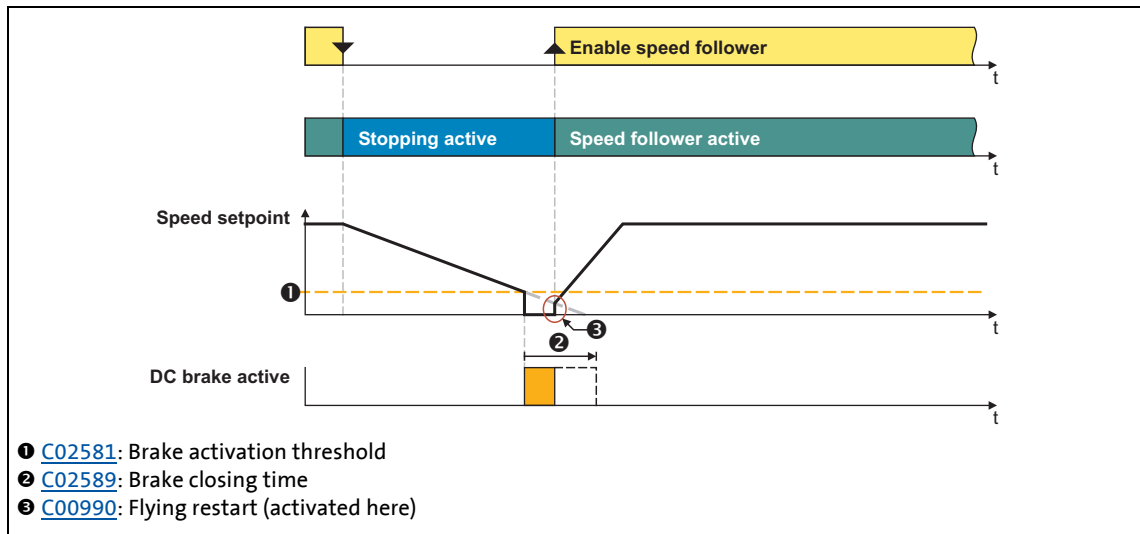

[11-43] Example 2: Speed follower active → stopping active (stopping time > brake closing time) → speed follower active

### Automatic DC-injection braking when quick stop is activated

DC-injection braking is activated automatically if a quick stop is triggered in the drive, e.g. via the basic function "[Quick stop](#)" or as a response to an error.

- A change-over to the "Quick stop active" function state is effected, and for the quick stop deceleration time set in [C00105](#) a DC-injection braking process with the braking current set in [C00975](#) is carried out.
- After this time has elapsed, a change-over to the braking current parameterised in [C00974](#) is carried out and DC-injection braking is continued with this braking current.
- After the brake closing time set in [C02589](#) has also elapsed, the basic function "Brake control" automatically sets controller inhibit.
- The DC-injection braking in this case is also carried out when the "Quick stop by trouble" error response is actuated; however, instead of the "Quick stop active" function state, the "Fault" function state is active, and the controller is in the "Quick stop by trouble active" device state.

# 11 Basic drive functions

## 11.12 Brake control

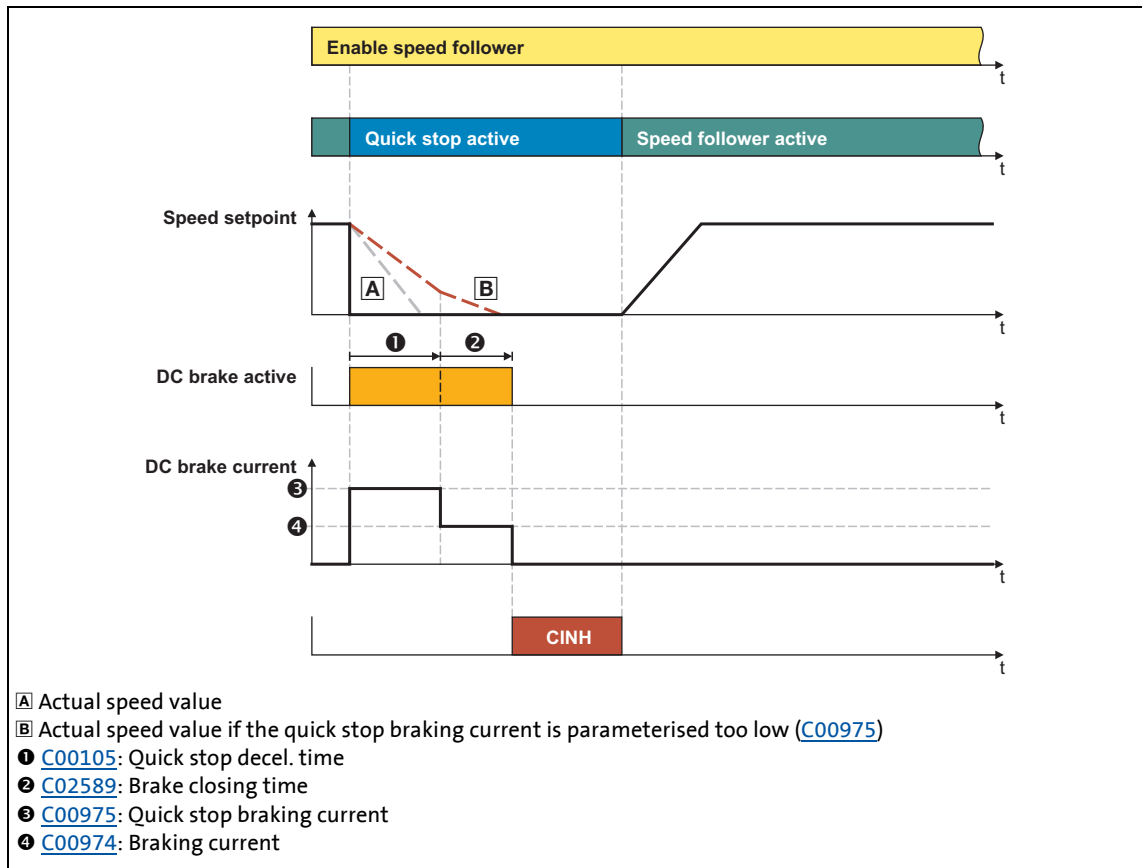

[11-44] Process example: speed follower is active → quick stop activation → speed follower is active



### Note!

The quick stop braking current in [C00975](#) has to be set so that the drive can be decelerated from the maximum operating speed to standstill within the deceleration time for quick stop set in [C00105](#)!



### 11.12.7 Grinding the brake

This function may be required after the brake has been replaced. The holding torque specified in the data sheet is only reached if the friction partners are ground in after mounting.



#### Stop!

If this function is activated, the drive is automatically accelerated to the grinding speed parameterised in [C02596](#).

- The axis must move freely without driving against the travel range limitations.
- The maximally permissible friction energy of the brake must not be exceeded (observe the specifications of the manufacturer)!

$$W_{\text{total}}[\text{J}] \sim M_{\text{K}}[\text{Nm}] \cdot \frac{2\pi}{60} \cdot N[\text{min}^{-1}] \cdot t_{\text{total}}[\text{s}]$$

[11-45] Formula for estimating the friction energy during grinding process

#### Prerequisites

In order to be able to activate the grinding of the brake, the following conditions must be fulfilled:

- The grinding speed in [C02596](#) is set higher than 0 rpm.
- The brake is activated, i.e. the "brake closing time" ([C02589](#)) and the "waiting time for status monitoring" ([C02591](#)) are elapsed.
- No other source for controller inhibit is active so that the controller inhibit can be deactivated by the brake control.



#### Note!

When grinding the brake, ensure that the motor shaft can be kept at speed against the closed holding brake.

- For this purpose, make sure that the maximum torque of the motor control ([C00057/2](#)) is higher than the holding torque of the brake.

### Procedure

If all requirements mentioned before have been met, the grinding process can be started by setting the input *BRK\_bBrakeGrindIn* to TRUE.

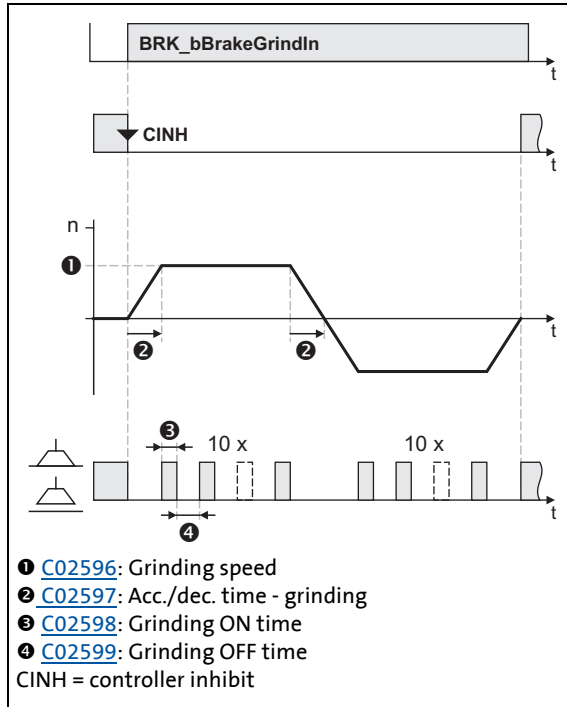

- After the grinding speed has been reached, the friction partners in the brake are ground by a pulse-type control.
- After the brake has been closed and opened ten times, the direction of rotation changes and grinding in the opposite direction is carried out.
- By resetting the input *BRK\_bBrakeGrindIn* to FALSE the grinding process can be aborted.

[11-46] Sequence of the grinding operation

### 11.12.8 Carrying out brake test

This function can be used to check the holding torque of the brake.



#### Tip!

You can carry out this test in regular intervals, e. g. to detect a defect or wear of the brake at an early stage.



#### Note!

Due to possible deviations in the torque generation, the test of the holding torque cannot determine the holding torque exactly!

- The generated motor torque can deviate up to  $\pm 15\%$  from the default value depending on temperature.
- The test torque is internally limited to the value of the motor reference torque ([C00057/2](#)). A higher parameterisation of [C02594](#) is automatically limited to this value.

#### Prerequisites

In order to be able to activate the brake test, the following requirements have to be met:

- The test torque in [C02594](#) is set higher than 0 Nm.
- The permissible angle of rotation is set greater  $0^\circ$  in [C02595](#), thus standstill monitoring is active. ▶ [Standstill monitoring](#) (📖 531)
- The brake is activated, i.e. the "brake closing time" ([C02589](#)) and the "waiting time for status monitoring" ([C02591](#)) are elapsed.
- No other source for controller inhibit is active so that the controller inhibit can be deactivated by the brake control.

### Procedure

If all requirements mentioned before have been met, the brake test can be started by setting the input *BRK\_bBrakeTest* to TRUE.

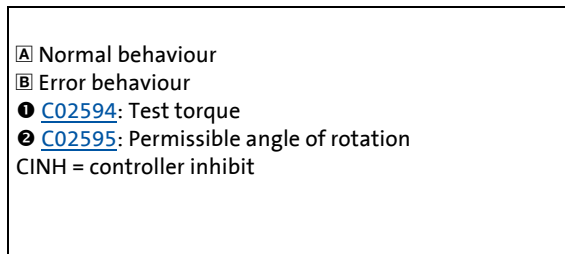

[11-47] Sequence of the brake test

- The specified test torque is created via a ramp generator with an acceleration time of 1 s and held max. 4 s.
  - By this the motor shaft tries to rotate while the brake is applied.
- By resetting the input *BRK\_bBrakeTest* to FALSE the brake test can be aborted.

### Error behaviour

If during the brake test the stop position of the motor axis has changed by more than the permissible angle of rotation set in [C02595](#), although the brake is engaged:

- The brake test is cancelled immediately and "Quick stop by trouble" is activated as error response to avoid a further rotation/acceleration of the drive.
- The error message "Motor brake: Angular drift with closed brake too high" is entered into the logbook.
- The status "position drift when brake is applied" is displayed for one cycle at the *BRK\_dnState* status output via bit 21 and the status "brake error" is displayed via bit 15.
- The *BRK\_bError* output is set to TRUE for one task cycle.

# 11 Basic drive functions

## 11.12 Brake control

### 11.12.9 Control of two motor holding brakes

The technical implementation is based on the control of an external relay by a digital output. The relay contact then switches an external 24-V supply for both motor holding brakes:

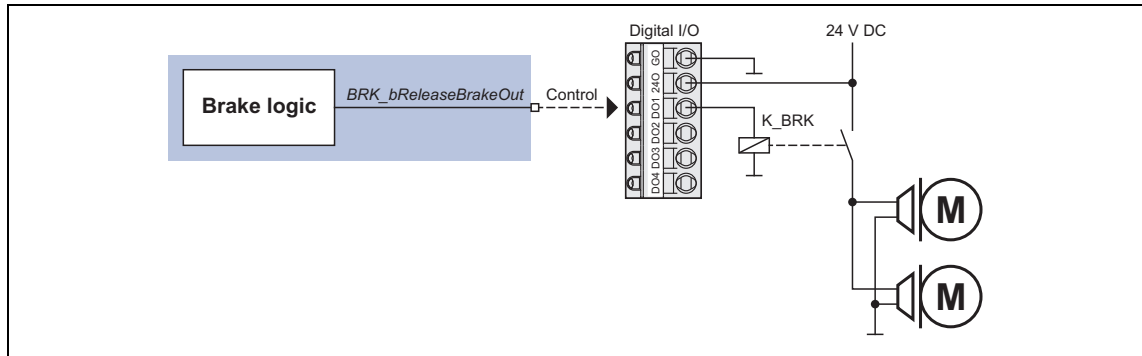

[11-48] Interconnection example for controlling two motor holding brakes



#### Tip!

From software version V7.0 onwards, two motor temperature sensors can be evaluated simultaneously via the two encoder inputs X7 and X8 when two motor are used (e.g. double motor for a storage and retrieval unit).

► [Temperature monitoring of a second motor](#) (📖 228)

# 11 Basic drive functions

## 11.13 Cam data management

---

### 11.13 Cam data management

This function extension is available from software version V3.0!

---

The basic function "Cam data management" provides different functions for the systemwide management of the cam data available in the memory module for a cam application.

- Cam data are motion profiles/characteristics, cam tracks, and position marks.
- The cam data required can either be created using the »Cam Editor« and transmitted to the controller by means of »Engineer«, or they can be directly entered via the parameters of this basic drive function if cam data have already been downloaded.



#### Note!

For the use of cam data in the controller, the licence level Motion Control TopLevel is required!

### 11.13.1 "Online" tab for cam data management

After an interconnection has been created via the electrical shaft, it is shown in the *Project view* with the axes assigned:



If you select the axis representing the 9400 HighLine controller under the electrical shaft, the **Online** tab for cam data management is provided in the *Workspace*:

Info	
A	<b>Cam-data-compatible</b> <ul style="list-style-type: none"> <li>This property is set automatically for the controller if the controller supports cam data (licence level Motion Control TopLevel required).</li> <li><b>Note: The checkmark must not be removed, as otherwise the assignment to the cam data is lost!</b></li> </ul>
B	<b>Cam data status</b> <ul style="list-style-type: none"> <li>The first green LED for instance is lit if the cam data file in the project is active.</li> <li>When an online connection to the controller has been established, also the status of the cam data available in the controller is shown.</li> </ul>
C	Display of the current memory distribution for the cam data. ▶ <a href="#">Memory distribution (559)</a>
D	Configuration of the access protection for the cam data. ▶ <a href="#">Access protection (560)</a>
E	Possibility for quickly updating the cam data in the controller (without having to transfer the complete application). ▶ <a href="#">Regenerating the cam data file and transferring it to the controller (562)</a>

### 11.13.1.1 Memory distribution

From software version V5.0 there are three different storage modes for the distribution of the cam data memory in the controller. The specification of the storage mode is effected automatically by the »Engineer« when the cam data file is generated.



#### Note!

For controllers with a software version lower than V5.0 the memory distribution always corresponds to storage mode 1 (see following table), i. e. the max. size of the cam data file is limited to 256 kBytes.

Storage modes 2 and 3 automatically provide a greater memory for an extensive amount of cam data, however, in return certain functions are no longer supported (e. g. changing cam data via parameterisation).

Memory distribution of the cam data	Display in [bytes]	Storage mode		
		1	2*	3*
Memory module	-	262144 bytes (256 kBytes)	524288 bytes (512 kBytes)	1048576 bytes (1024 kBytes)
Internal RAM for quick download	<a href="#">C02901/1</a>	262144 bytes (256 kBytes)	0 bytes	0 bytes
Internal RAM for online change	<a href="#">C02901/2</a>	131072 bytes (128 kBytes)	262144 bytes (256 kBytes)	0 bytes
Internal RAM for cam data	<a href="#">C02901/3</a>	131072 bytes (128 kBytes)	262144 bytes (256 kBytes)	524288 bytes (512 kBytes)

\* Only from software version V5.0

Functions supported	Storage mode		
	1	2*	3*
<a href="#">Changing cam data via parameterisation</a>	●		
Quick download to the RAM	●		
<a href="#">Online change</a>	●	●	
Device command " <a href="#">Load cam data</a> "	●	●	●
Device command " <a href="#">Save cam data</a> "	●		
Device command " <a href="#">Calculate cam data</a> "	●	●	●
Device command " <a href="#">Calculate cam data checksum</a> "	●		

\* Only from software version V5.0



### 11.13.1.2 Access protection

If required, the cam data can be protected against unauthorised or unintentional change by means of a three-stage access protection concept:

#### Step 1: Access protection deactivated

- There is no access protection for the upload/download of new cam data and the change of cam data via parameters.

#### Step 2: Access protection via user password

- The user password must be entered for the upload/download of new cam data and the change of password-protected cam data via parameters.

#### Step 3: Linking the cam data to the serial number of the memory module

- The user password must be entered for the upload/download of new cam data and the change of password-protected cam data via parameters.
- In addition, the serial number of the memory module must comply with the serial number given in »Engineer« for the cam data.



#### Note!

The settings for the access protection are firmly defined for the existing cam data and cannot be changed.

For a change of the settings the cam data have to be updated in »Engineer« and then transferred to the controller. These two actions can be carried out on the **Online** tab via the buttons **Generate cam data file** and **Transfer cam data to the device**.

▶ [Regenerating the cam data file and transferring it to the controller](#) (562)



#### How to define a password for the cam data:

1. Click the lower **Password** button (for new password).
  - The *Change password* dialog box appears:

The dialog box titled "Change password" has a blue header. The main area is light beige and contains the text "Please enter your password for locking Cam-data of the drive". Below this text are two input fields: "Password:" and "Enter password again:". At the bottom right of the dialog box are two buttons: "OK" and "Cancel".

2. Enter desired user password.
3. Click **OK** to accept the entry and close the dialog box.

**How to change an existing password:**

1. Click upper **Password** button (for existing password).
2. Enter the existing user password in the *Change password* dialog box.
3. Click **OK** to accept the entry and close the dialog box.
4. Click the lower **Password** button (for new password).
5. Enter the new user password in the *Change password* dialog box.
6. Click **OK** to accept the entry and close the dialog box.

**Tip!**

An existing access protection via user password can be cancelled again by carrying out the steps described before for changing the password and simply leaving blank the input field for the new password.

**How to link the cam data to the serial number of the memory module:**

Go to the **Serial number** input field and enter the serial number of the memory module.

- When an online connection to the controller has been established, you can read out the serial number of the memory module in the controller by clicking the **Read from device** button.

**Tip!**

The linkage of the cam data to the serial number of the memory module can be cancelled again by carrying out the steps described before and simply leaving blank the **Serial number** input field.

### 11.13.1.3 Regenerating the cam data file and transferring it to the controller

If you transfer the parameter set or the application from »Engineer« to the controller, the cam data are also transferred automatically to the controller.

To only regenerate the cam data file and transferring it to the controller, after the cam data have been changed in the »Cam Manager« or the settings have been changed for access protection, carry out the following steps:



#### How to update the cam data:

- Click on the **Generate cam data file** button on the **Online** tab to regenerate the cam data file for the controller.
  - The cam data status shown and the information with regard to the memory distribution on the **Online** tab are updated. The green LED behind "In the project" is lit now, which means that the cam data file in the project is active:

Cam data status	Time stamp for data generation	Generated data volume for next transfer
In Project	23.10.2008 07:51:24	9 kbytes
In RAM		
Processing		5 kbytes
In memory module		

When an online connection has been established to the controller:

- To transmit the cam data to the controller, click the **Download cam data** button.
  - The new/altered cam data are accepted in the controller according to the online change mode set. ▶ [Online change mode](#) (□ 567)
  - The green LED behind "In the memory module" is now lit as well, which means that the cam data file in the memory module is also active:

Cam data status	Time stamp for data generation	Generated data volume for next transfer
In Project	23.10.2008 07:51:24	0 kbytes
In RAM	23.10.2008 07:51:24	
Processing	23.10.2008 07:51:24	5 kbytes
In memory module	23.10.2008 07:51:24	

### 11.13.2 Internal interfaces | "LS\_CamInterface" system block

The **LS\_CamInterface** system block provides the internal interfaces for cam data management in the function block editor.

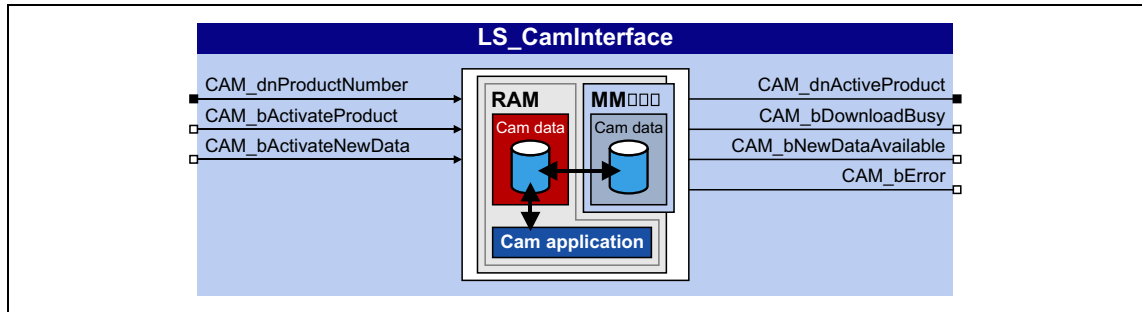

#### Inputs

Identifier <small>DIS code   data type</small>	Information/possible settings		
CAM_dnProductNumber <small>DINT</small>	Product number <ul style="list-style-type: none"> <li>The basic function manages the product number for all cam FBs within the application.</li> <li>The product number is displayed in the »Cam Manager« in squared brackets after the product name.</li> <li>If the product number is to be defined via parameter instead, a corresponding user code must be created in the application and connected with this input.</li> <li>The highest product number to be created is shown in <a href="#">C02908</a>.</li> </ul>		
CAM_bActivateProduct <small>BOOL</small>	Activate product <ul style="list-style-type: none"> <li>The change-over to another product is caused by an event which is generated from the application.</li> </ul> <table border="1" style="width: 100%; margin-top: 5px;"> <tr> <td style="text-align: center;">TRUE</td> <td>The product with the product number at input <i>CAM_dnProductNumber</i> is activated.</td> </tr> </table>	TRUE	The product with the product number at input <i>CAM_dnProductNumber</i> is activated.
TRUE	The product with the product number at input <i>CAM_dnProductNumber</i> is activated.		
CAM_bActivateNewData <small>BOOL</small>	Reload cam data from the backup memory (controlled acceptance) <ul style="list-style-type: none"> <li>Only possible if the online change mode "10: Manual Activation" is set in <a href="#">C02905</a>.</li> <li>If the online change mode "16: Automatic activation with CINH" (Lenze setting) or "15: Automatic activation" is set in <a href="#">C02905</a>, the new cam data are accepted immediately after a download and this input has no function.</li> <li>The current status of the data acceptance is shown in <a href="#">C02906</a>.</li> </ul> <table border="1" style="width: 100%; margin-top: 5px;"> <tr> <td style="text-align: center;">TRUE</td> <td>Reload cam data from the backup memory.</td> </tr> </table>	TRUE	Reload cam data from the backup memory.
TRUE	Reload cam data from the backup memory.		

## Outputs

Identifier <small>DIS code   data type</small>	Value/meaning	
CAM_dnActiveProduct <small>C02909   DINT</small>	Product number of the currently active product	
CAM_bDownloadBusy <small>BOOL</small>	Status signal "Download/data change active" • The current status of the data acceptance is shown in <a href="#">C02906</a> .	
	TRUE	Currently the cam data in the RAM of the controller are changed. • For instance, due to parameter set transfer, device command C00002 = "501: Load cam data" or change of the cam data via parameters.
	TRUE↔FALSE	Download/data change completed. • In order to detect if the download/ the data change has been completed correctly, the <i>CAM_bError</i> error output should also be evaluated.
CAM_bNewDataAvailable <small>BOOL</small>	Status signal "New cam data available"	
	TRUE	The internal recalculation of the new/changed cam data is completed and the cam data are ready for acceptance. • The time when the new/changed cam data are accepted depends on the online change mode set in <a href="#">C02905</a> . ▶ <a href="#">Online change mode (567)</a> • In the Lenze setting the new/changed cam data are accepted automatically as soon as the controller inhibit is set within the controller. • If the online change mode "15: Automatic activation" is set in <a href="#">C02905</a> , the new/changed cam data are accepted immediately after the internal recalculation and the TRUE signal is only pending for one task cycle.
CAM_bError <small>BOOL</small>	"Fault" status signal	
	TRUE	An error has occurred (group signal).

## 11.13.3 Parameter setting

Short overview of the parameters for cam data management:

Parameters	Info	Effective in storage mode		
		1	2*	3*
<a href="#">C00198</a>	Axis number	●	●	●
<a href="#">C02900</a>	User Password	●	●	●
<a href="#">C02901</a>	Cam storage capacity	●	●	●
<a href="#">C02902</a>	Time stamp of cam data	●	●	●
<a href="#">C02903</a>	GUID cam data	●	●	●
<a href="#">C02905</a>	Online change mode	●	●	
<a href="#">C02906</a>	Online change status	●	●	●
<a href="#">C02908</a>	Number of products	●	●	●
<a href="#">C02909</a>	Active Product	●	●	●
<a href="#">C02910</a>	Product designation	●	●	●
<a href="#">C02911</a>	Product Choice	●	●	●
<a href="#">C02912</a>	Number of products	●		
<a href="#">C02919</a>	Number of curve tracks	●		
<a href="#">C02920</a>	Cam Track Choice	●	●	●
<a href="#">C02921</a>	Cam Track Type	●		
<a href="#">C02922</a>	Number of Cam Data Points	●		
<a href="#">C02923</a>	Cam Data Point Choice	●	●	●
<a href="#">C02924</a>	Change Cam Data Point X	●		
<a href="#">C02925</a>	Change Cam Data Point Y	●		
<a href="#">C02926</a>	Torque feedforward control value	●		
<a href="#">C02927</a>	Auto Inc Cam Data Points	●	●	●
<a href="#">C02939</a>	Number of Cont Tracks	●		
<a href="#">C02940</a>	Cont Track Choice	●	●	●
<a href="#">C02941</a>	Cam type	●	●	●
<a href="#">C02942</a>	Number of Cont Data Points	●		
<a href="#">C02943</a>	Cont Data Point Choice	●	●	●
<a href="#">C02944</a>	Cont Pos X0	●		
<a href="#">C02945</a>	Cont Pos X1	●		
<a href="#">C02946</a>	Cont Time	●		
<a href="#">C02959</a>	Number of Position Tracks	●		
<a href="#">C02960</a>	Pos Track Choice	●	●	●
<a href="#">C02962</a>	Number of Pos Data Points	●		
<a href="#">C02963</a>	Pos Data Point Choice	●	●	●
<a href="#">C02964</a>	Change Pos Data Point X	●		
<a href="#">C02965</a>	Change Pos Data Point Y	●		

Greyed out = display parameter  
 \* Storage modes 2 and 3 are only available from software version V5.0. Parameters that are not effective are set to zero.

### 11.13.3.1 Password entry

If a password has been defined for the cam data in »Engineer«, the defined user password must be entered once to execute the following actions:

- Download of new cam data during operation  
→ Entry of the existing password in »Engineer«.
- Change of the cam data via parameter setting  
→ Entry of the existing password in [C02900](#).
- Loading/saving of the cam data  
→ entry of the existing password in [C02900](#).



#### Note!

From software version V4.0 onwards, you do not need to enter a possibly existing user password ([C02900](#)) if you want to save the cam data.



#### Tip!

The access protection for the cam data can be configured on the **Online** tab. ▶ ["Online" tab for cam data management](#) (📖 558)

#### Validity

The user password entered in [C02900](#) is maintained until the next download, mains switching, or until reset by the user (logout).

- You can "log out" deliberately by entering an invalid password into [C02900](#).

#### Behaviour in case of invalid entry

If the user password is entered incorrectly three times, the cam data are blocked. A correct entry resets the number of the failed attempts.

To remove the blocking of the cam data, there are two possibilities:

- A. Resetting the parameters to the Lenze setting via device command [C00002](#) = "0: Load Lenze setting".
  - When the Lenze setting is loaded, the cam data are deleted.
  - Afterwards the cam data can be transferred to the device again.
- B. Transfer complete application to the device again.
  - The application available and the cam data are deleted and all data are transferred to the device again.

### 11.13.3.2 Online change mode

During running operation, new cam data can be downloaded from »Engineer« to the controller if the controller is in storage mode 1 or 2.

- If the cam data are provided with an access protection, the user password has to be entered first.
  - ▶ [Access protection](#) (📖 560)
- The time when the new/altered cam data are accepted depends on the online change mode set in [C02905](#).



#### Note!

If the controller is in storage mode 3, the "Online change" function is deactivated:

- The online change mode set in [C02905](#) is ineffective.
- In [C02906](#) the status "999: Online change deactivated" is displayed.
- For the download of new cam data, controller inhibit is required.
- The cam data are accepted immediately after download.

▶ [Memory distribution](#) (📖 559)

#### Mode 16: Automatic activation with CINH

In the Lenze setting, the online change mode "Automatic activation with CINH" is set in [C02905](#), i.e. the new cam data are accepted automatically as soon as the controller is inhibited.

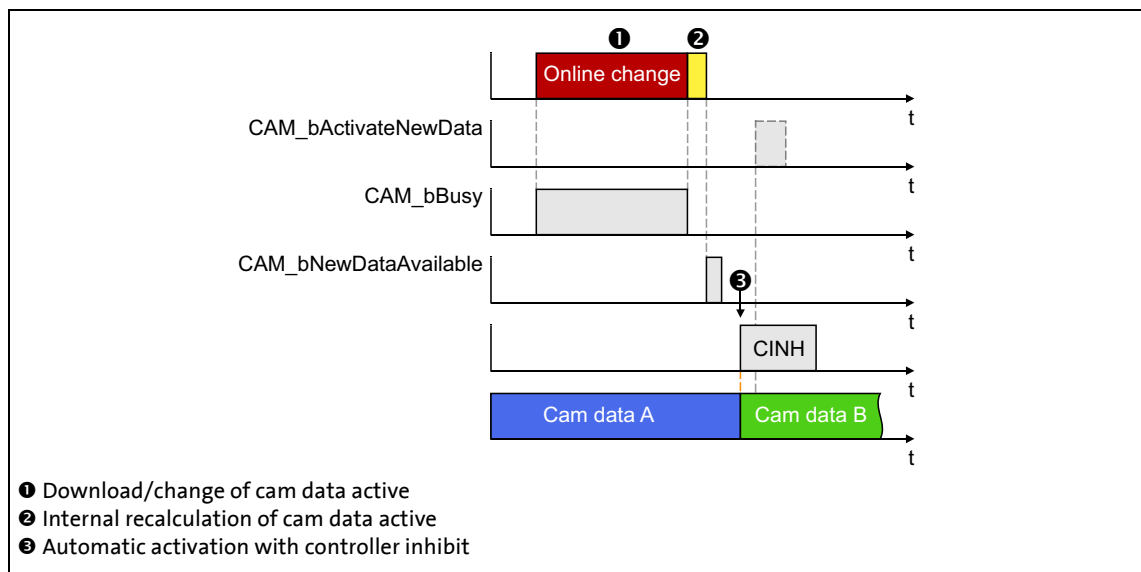

[11-49] Online change mode "Automatic activation with CINH"



### Mode 15: Automatic activation

In the online change mode "Automatic activation", the new cam data are accepted directly after the internal recalculation of the data from the application unit [unit] into the internal unit [increments] has been completed.

- The controller does not need to be inhibited for acceptance.

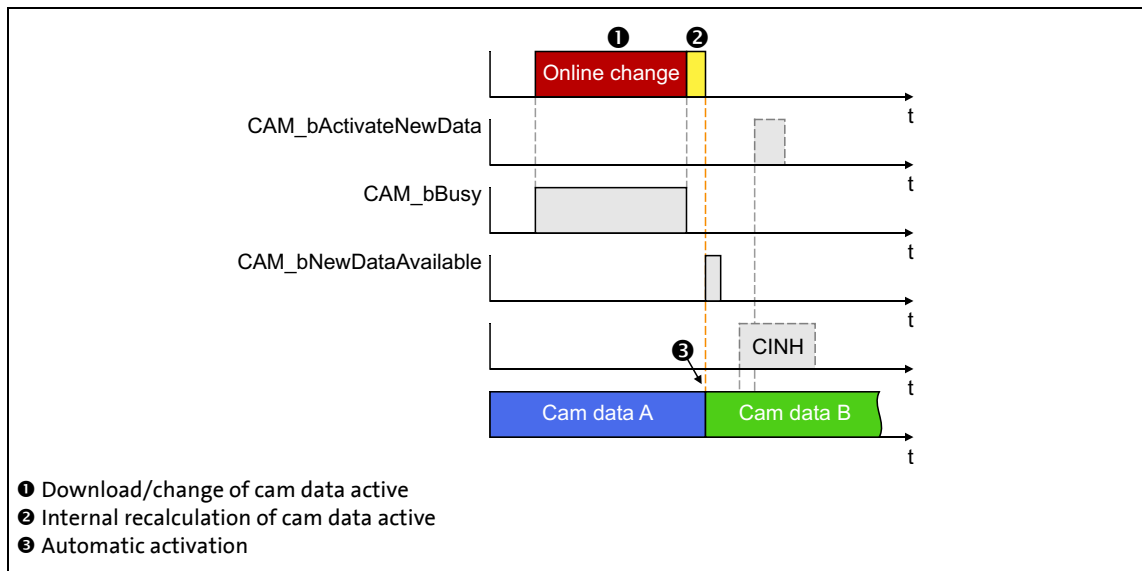

[11-50] Online change mode "Automatic activation"

### Mode 10: Manual activation

In the online change mode "Manual activation", the new cam data are accepted when the `CAM_bActivateNewData` control input is set to TRUE.

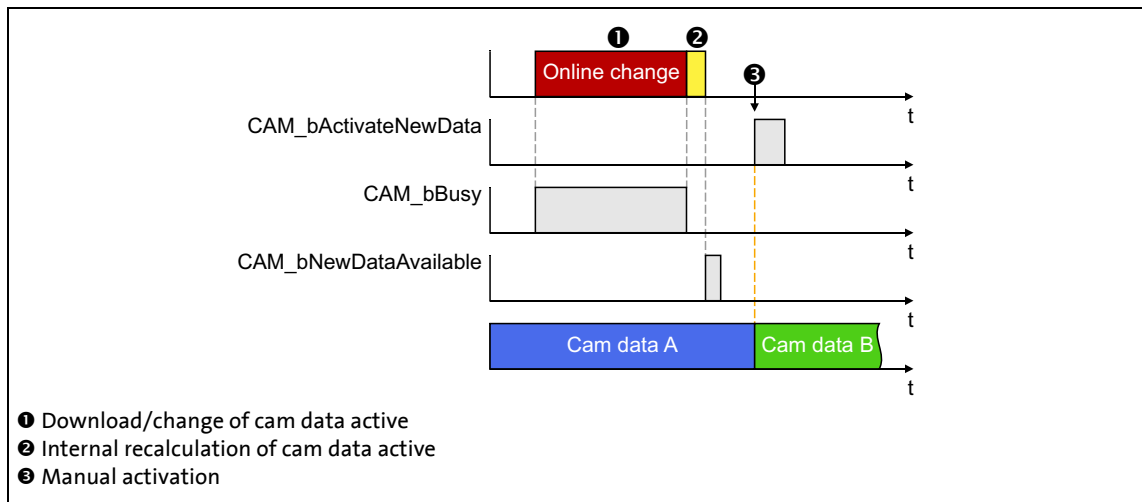

[11-51] Online change mode "Manual activation"

### 11.13.3.3 Changing cam data via parameterisation

If required, the cam data (motion profiles/characteristics, cams, and position markers) can be changed via corresponding parameters if the controller is in storage mode 1. Except for the last interpolation point, all interpolation points of an electronic cam can be changed via the parameter access.

- If the cam data are provided with an access protection, the user password has to be entered in [C02900](#) first. ▶ [Access protection](#) (□ 560)
- **From software version V4.0 onwards**, the time stamp of the cam data is updated if the cam data are changed by parameter setting. This enables, for instance, the »Engineer« to recognise that the cam data of the »Engineer« project and those of the controller differ.



#### Note!

If the controller is in storage mode 2 or 3, the cam data cannot be changed via parameterisation. All parameters for change are ineffective and set to zero. ▶ [Memory distribution](#) (□ 559)

If the cam data of the controller have been changed by parameter setting, the [C00002](#) = "504: Calculate Cam Checksum" device command has to be executed afterwards. ▶ [Calculate cam data checksum](#) (□ 95)

Then the cam data can be converted into the internal format with the "503: Calculate Cam Data" device command or saved on the memory module in a powerfail-proof manner with the "502: Save Cam Data" device command. ▶ [Calculate cam data](#) (□ 94) / ▶ [Save cam data](#) (□ 92)

**From software version V4.0 onwards**, the changed cam data and the parameters can be saved together on the memory module in a powerfail-proof manner with the [C00002](#) = "11: Save start parameters" device command. ▶ [Save start parameters](#) (□ 52)



#### How to change an interpolation point in a curve (motion profile or characteristic):

1. Go to [C02911](#) and set the product number of the product to be edited.
2. Go to [C02920](#) and set the track number of the curve track to be edited.

#### Tip!

In [C02921](#) the curve type, and in [C02922](#) the number of interpolation points of the curve selected is shown.

3. Set the interpolation point to be edited in [C02923](#).
4. Change the desired parameters of the selected grid point:
  - [C02924](#): x position
  - [C02925](#): y position
  - [C02926](#): Torque feedforward control value (only in case of a motion profile with feedforward control.)

**Tip!**

[C02927](#) serves to activate a grid point auto increment if several successive grid points are to be changed.

- When the grid point auto increment is activated, it is automatically incremented to the next grid point every time the y position is written into [C02925](#) so that the specification of the grid point to be changed in [C02923](#) is only required once.

**How to change several successive grid points (auto increment):**

1. Go to [C02911](#) and set the product number of the product to be edited.
2. Go to [C02920](#) and set the track number of the curve track to be edited.

**Tip!**

In [C02921](#) the curve type, and in [C02922](#) the number of interpolation points of the curve selected is shown.

3. Set selection "1: Activate" in [C02927](#) to activate the grid point auto increment.
4. Set the grid point from which on the grid point auto increment is to be started in [C02923](#).
5. Set the following parameters for the grid point set in [C02923](#) in the given order:
  - [C02924](#): x position
  - [C02926](#): Torque feedforward control value (only in case of a motion profile with feedforward control.)
  - [C02925](#): y position

After the y position is written into [C02925](#) it is automatically incremented to the next grid point.

6. Set the parameters for the next grid point in the same order:
  - [C02924](#): x position
  - [C02926](#): Torque feedforward control value (only in case of a motion profile with feedforward control.)
  - [C02925](#): y position
7. Repeat step 4 until all grid points are changed.

**Note:** Do not change more grid points than available (depending on the start grid point). Changing a non-available grid point causes an error message!

**How to change a cam:**

1. Go to [C02911](#) and set the product number of the product to be edited.
2. Go to [C02940](#) and set the track number of the cam track to be edited.

**Tip!**

The cam type is displayed in [C02941](#) and the number of cams of the selected cam data is displayed in [C02942](#).

3. Go to [C02943](#) and set the cam to be edited.
4. Change the desired parameters of the selected cam:
  - [C02944](#): Cam position X0
  - [C02945](#): Cam position X1
  - [C02946](#): Cont Time (for position/time cams)

**How to change a position mark:**

1. Go to [C02911](#) and set the product number of the product to be edited.
2. Go to [C02960](#) and set the track number of the position track to be edited.

**Tip!**

In [C02962](#) the number of the position marks of the position data selected is shown.

3. Set the position mark to be edited in [C02963](#).
4. Change the desired parameters of the selected position mark:
  - [C02964](#): x position
  - [C02965](#): y position

### 11.13.4 Product/track change-over

#### Product change-over

The change-over to another product number is effected for all cam FBs within the application via the basic function "Cam data management".

- The change-over is effected via the input *CAM\_bActivateProduct* on the basis of an event that is generated from the application.
- By setting the input *CAM\_bActivateProduct* to TRUE, the product is activated with the product number at input *CAM\_dnProductNumber*.

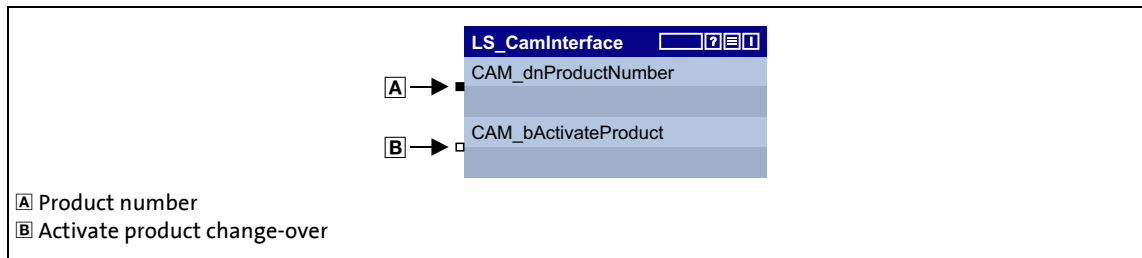

[11-52] Principle: Product change-over

#### Track switch-over

The change-over to another curve track, cam track, or position track, however, is individually effected via the input *dnTrackNumber* at the respective cam function block.

- For the two FBs *L\_CamProfiler* and *L\_CamContactor* it can be parameterised whether the track change-over is to be effected in the next zero crossing of the x axis or immediately (Lenze setting: in the next zero crossing).

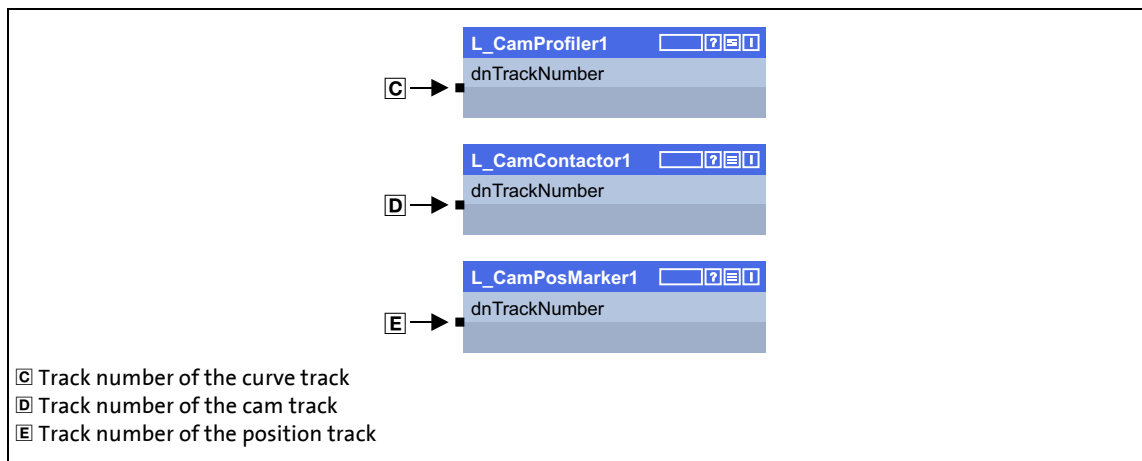

[11-53] Principle: Track change-over

### 11.13.5 Invalid cam data due to changed machine parameters

This function extension is available from software version V4.0!

If one or more machine parameters affecting the internal scaling of the cam data are changed, the message "Cam Data: Invalidated due to change of mechanical data" (error number [0x00b80034](#)) is entered into the logbook and the error response "Warning" occurs.

- The cam data are no longer valid and have to be recalculated.
- The warning is automatically reset if the [C00002](#) = "503: Calculate Cam Data" device command is executed. ▶ [Calculate cam data](#) (📖 94)

**Machine parameters affecting the internal scaling of the cam data:**

Parameters	Info
<a href="#">C00006</a>	Selection of the motor control
<a href="#">C00100</a>	Resolution of an encoder revolution
<a href="#">C02520</a> / <a href="#">C02521</a>	Gearbox factor - motor (if motor = reference source)
<a href="#">C02522</a> / <a href="#">C02523</a>	Gearbox factor - position encoder (if position encoder = reference source)
<a href="#">C02524</a>	Feed constant
<a href="#">C02570</a>	Position control structure

### 11.13.6 Behaviour after mains switching

After mains switching, the cam data are loaded from the memory module into the controller between loading and start of the application.



#### Note!

During the initialisation no check of the user password takes place, but a check of the serial number of the memory module is carried out, if this access protection has been activated by the user in »Cam Designer«. If the serial number specified and the serial number of the memory module do not match, the cam data are not loaded.

- The "Cam data: serial number" error message is entered in the logbook.
- The "Warning locked" error response occurs.

If a download of cam data that was carried out before mains switching was not completed correctly, the previous cam data – if available – are loaded by the memory module.

- The "Cam data restored" error message is entered into the logbook.
- The "Fault" error response occurs.
- After the error is reset (acknowledged), operation with the previous cam data is possible.

### 11.14 Pole position identification

This function extension is available from software version V7.0!

---



#### Danger!

In this basic function, the extent of the useable operating modes of the holding brake is restricted. Only the following operating modes function:

- Directly with brake module ([C02580, selection 1](#)) and
- Direct switching externally ([C02580, selection 11](#))

The device commands "Identify pole position (360°)" and "Identify pole position (min. motion)" serve to execute an identification of pole position to detect the pole position to the motor encoder currently activated in [C00495](#).

From software version V7.0 onwards, the identification of pole position is additionally available as a basic function in the form of the [LS PolePositionIdentification](#) system block.



#### Note!

An identification of pole position is only required:

- For servo control with synchronous motor of a third-party manufacturer.
- For servo control with synchronous motor and use of incremental encoders (TTL or sin/cos encoders as well as multi-pole pair resolvers).
- After changes of the motor feedback system, e.g. encoder exchange.

Detailed information on the identification of pole position can be found in the subchapter "[Pole position identification](#)" for the motor interface. ([131](#))



11.14.1 Internal interfaces | System block "LS\_PolePositionIdentification"

The **LS\_PolePositionIdentification** system block provides the internal interfaces for the basic function "Pole position identification" in the function block editor.

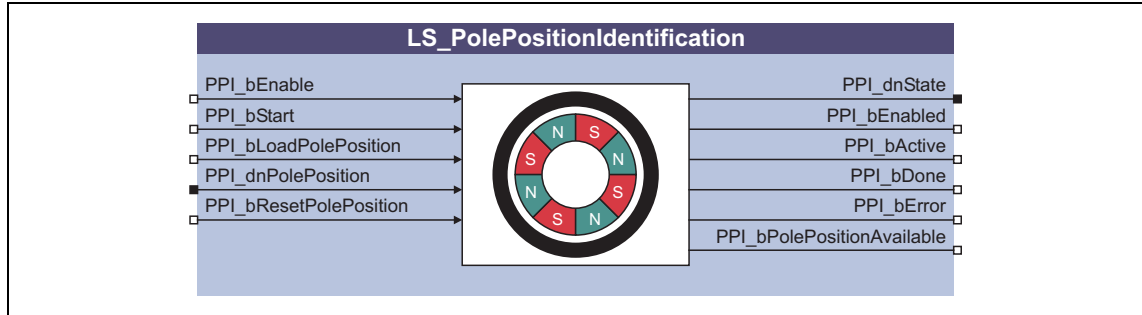

**Note!**

Ensure that the system block is called in a cyclic application task.

Basically, projects which only contain an unsolicited task and no cyclic task are not permissible!

**Inputs**

Identifier <small>DIS code   data type</small>	Information/possible settings			
PPI_bEnable <a href="#">C02789/1</a>   BOOL	Request control of basic function			
	<table border="0"> <tr> <td style="text-align: center;">TRUE</td> <td>If no other basic function is active, a change-over to the "Identification of pole position active" function state is effected and an identification of pole position can be carried out via the control inputs.</td> </tr> <tr> <td style="text-align: center;">TRUE↘FALSE</td> <td>An active identification of pole position is stopped, i.e. a change-over from the active "Identification of pole position active" function state back to the "Controller not ready" basic state is effected.</td> </tr> </table>	TRUE	If no other basic function is active, a change-over to the "Identification of pole position active" function state is effected and an identification of pole position can be carried out via the control inputs.	TRUE↘FALSE
TRUE	If no other basic function is active, a change-over to the "Identification of pole position active" function state is effected and an identification of pole position can be carried out via the control inputs.			
TRUE↘FALSE	An active identification of pole position is stopped, i.e. a change-over from the active "Identification of pole position active" function state back to the "Controller not ready" basic state is effected.			
PPI_bStart <a href="#">C02789/2</a>   BOOL	For starting pole position identification			
	<table border="0"> <tr> <td style="text-align: center;">FALSE↗TRUE</td> <td>Pole position identification is started in the mode selected in <a href="#">C02786</a>.</td> </tr> </table>	FALSE↗TRUE	Pole position identification is started in the mode selected in <a href="#">C02786</a> .	
FALSE↗TRUE	Pole position identification is started in the mode selected in <a href="#">C02786</a> .			
PPI_bLoadPolePosition <a href="#">C02789/3</a>   BOOL	For starting pole position identification			
	<table border="0"> <tr> <td style="text-align: center;">FALSE↗TRUE</td> <td>The pole position angle applied at <i>PPI_dnPolePosition</i> is accepted in <a href="#">C00058/x</a>. • The subcode to be described of <a href="#">C00058</a> depends on the motor encoder selected in <a href="#">C00495</a>.</td> </tr> </table>	FALSE↗TRUE	The pole position angle applied at <i>PPI_dnPolePosition</i> is accepted in <a href="#">C00058/x</a> . • The subcode to be described of <a href="#">C00058</a> depends on the motor encoder selected in <a href="#">C00495</a> .	
FALSE↗TRUE	The pole position angle applied at <i>PPI_dnPolePosition</i> is accepted in <a href="#">C00058/x</a> . • The subcode to be described of <a href="#">C00058</a> depends on the motor encoder selected in <a href="#">C00495</a> .			
PPI_dnPolePosition <a href="#">C02788</a>   DINT	Pole position angle in [°] with one decimal position • Value range: -179.9 ... +179.9 °			
PPI_bResetPolePosition <a href="#">C02789/4</a>   BOOL	For resetting status "Pole position known"			
	<table border="0"> <tr> <td style="text-align: center;">FALSE↗TRUE</td> <td>The status outputs <i>PPI_bDone</i> and <i>PPI_bPolePositionAvailable</i> are reset to FALSE.</td> </tr> </table>	FALSE↗TRUE	The status outputs <i>PPI_bDone</i> and <i>PPI_bPolePositionAvailable</i> are reset to FALSE.	
FALSE↗TRUE	The status outputs <i>PPI_bDone</i> and <i>PPI_bPolePositionAvailable</i> are reset to FALSE.			

### Outputs

Identifier DIS code   data type	Value/meaning	
Ppi_dnState <a href="#">C02787</a>   DINT	Status (bit coded)	
	<ul style="list-style-type: none"> <li>When the basic function is not enabled, all bits are set to "0".</li> <li>Bits which are not listed are not assigned with a status (always "0").</li> </ul>	
	Bit 1	Pole position identification active.
	Bit 2	Pole position identification completed.
	Bit 14	Pole position known.
	Bit 15	An error has occurred (group signal).
PPI_bEnabled <a href="#">C02789/5</a>   BOOL	Status signal "Basic function is enabled"	
	TRUE	Pole position identification via the control inputs is possible. <ul style="list-style-type: none"> <li>The <i>PPI_bEnable</i> enable input is set to TRUE and the controller is in the "Pole position identification active" function state.</li> </ul>
PPI_bActive <a href="#">C02789/6</a>   BOOL	Status signal "Basic function is active"	
	TRUE	Pole position identification is active. <ul style="list-style-type: none"> <li>Output is reset to FALSE if the <i>PPI_bStart</i> input is reset to FALSE, controller enable is deactivated, or an error has occurred.</li> </ul>
PPI_bDone <a href="#">C02789/7</a>   BOOL	Status signal "Basic function is ready"	
	TRUE	Pole position identification is completed. <ul style="list-style-type: none"> <li>Output is reset to FALSE when input <i>PPI_bStart</i> is reset to FALSE.</li> </ul>
PPI_bError <a href="#">C02789/8</a>   BOOL	"Fault" status signal	
	TRUE	An error has occurred (group signal).
PPI_bPolePositionAvailable BOOL	Status signal "Pole position is known"	
	TRUE	The drive knows the pole position. <ul style="list-style-type: none"> <li>The value written into <a href="#">C00058/x</a> corresponds to the pole position (x depends on the motor encoder selected in <a href="#">C00422</a>).</li> </ul>

# 11 Basic drive functions

## 11.14 Pole position identification

---

### 11.14.2 Parameter setting

- Parameterisation dialog in »Engineer«: Tab **Application parameters** → Dialog level *Overview* → *All basic functions* → *Pole position identification*
- Short overview of parameters for pole position identification:

Parameters	Info
<a href="#">C02785</a>	Activation of PPI
<a href="#">C02786</a>	Mode of PPI
<a href="#">C02787</a>	Ppi_dnState
<a href="#">C02788</a>	PolePosition Setpoint
<a href="#">C02789</a>	PolePositionIdentification: Dig. signals

Greyed out = display parameter

### 11.14.3 Execution of the pole position identification

#### Prerequisites

- The controller inhibit is active.
- The controller has the "Controller not ready" function state.
- The basic function "Pole position identification" is part of the active application.
- No other basic function is active.

#### Activate basic function

To request the control via the basic function, the *PPI\_bEnable* enable input in the application must be set to TRUE.

- If no other basic function is active, a change-over to the "Identification of pole position active" function state is effected and an identification of pole position can be carried out via the control inputs.
- A successful change to the function state "Pole position identification active" is displayed by a TRUE signal at the *PPI\_bEnabled* status output.

**For starting pole position identification****Danger!**

The machine must not be braked or blocked during the pole position identification! For this reason, the pole position identification is not permitted for hanging loads!

During the pole position identification the rotor aligns itself. The motor shaft moves by max. one electrical revolution which causes the corresponding movement of the connected mechanical components!

**Stop!**

Check the correct parameterisation of the max. motor current monitoring ([C00619](#) and [C00620](#)) before carrying out the pole position identification to prevent the motor from being permanently damaged.

By setting the *PPI\_bStart* control input to TRUE, the pole position identification is started in the mode selected in [C02786](#).

- The procedure starts with controller enable, if
  - a synchronous machine is selected,
  - no other identification is active,
  - no error has occurred, and
  - no test mode is activated.
- If one of the above conditions is not met, the procedure is cancelled and the corresponding device command status is indicated via *PPI\_dnState*.

**Note!**

Detailed information on the identification of pole position can be found in the subchapter "[Pole position identification](#)" for the motor interface. ([131](#))

**Deactivation**

When the *PPI\_bEnable* enable input is reset to FALSE, an active pole position identification is stopped.

- If the pole position identification is aborted, no change is made in [C00058/x](#).
- The *PPI\_bEnabled* status output is reset to FALSE and a change-over from the active "Pole position identification active" function state back to the basic "Controller not ready" state is carried out".

# 11 Basic drive functions

## 11.14 Pole position identification

### 11.14.4 Signal characteristics

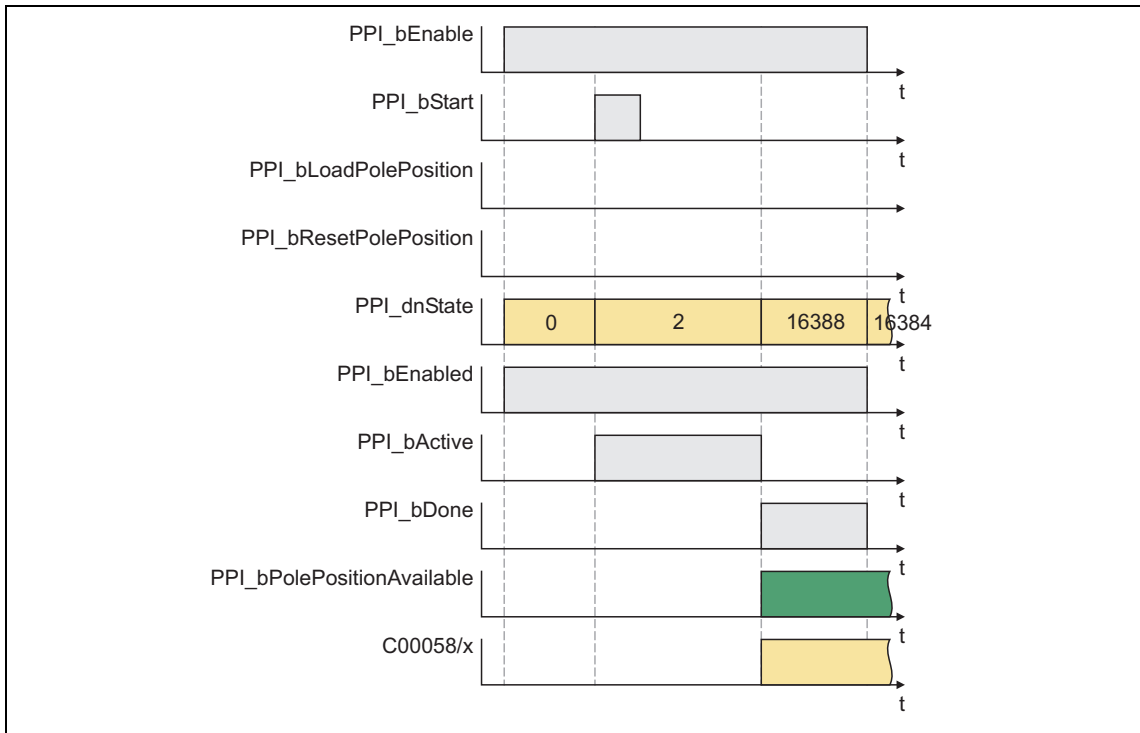

[11-54] Signal characteristic 1: Normal procedure of the pole position identification

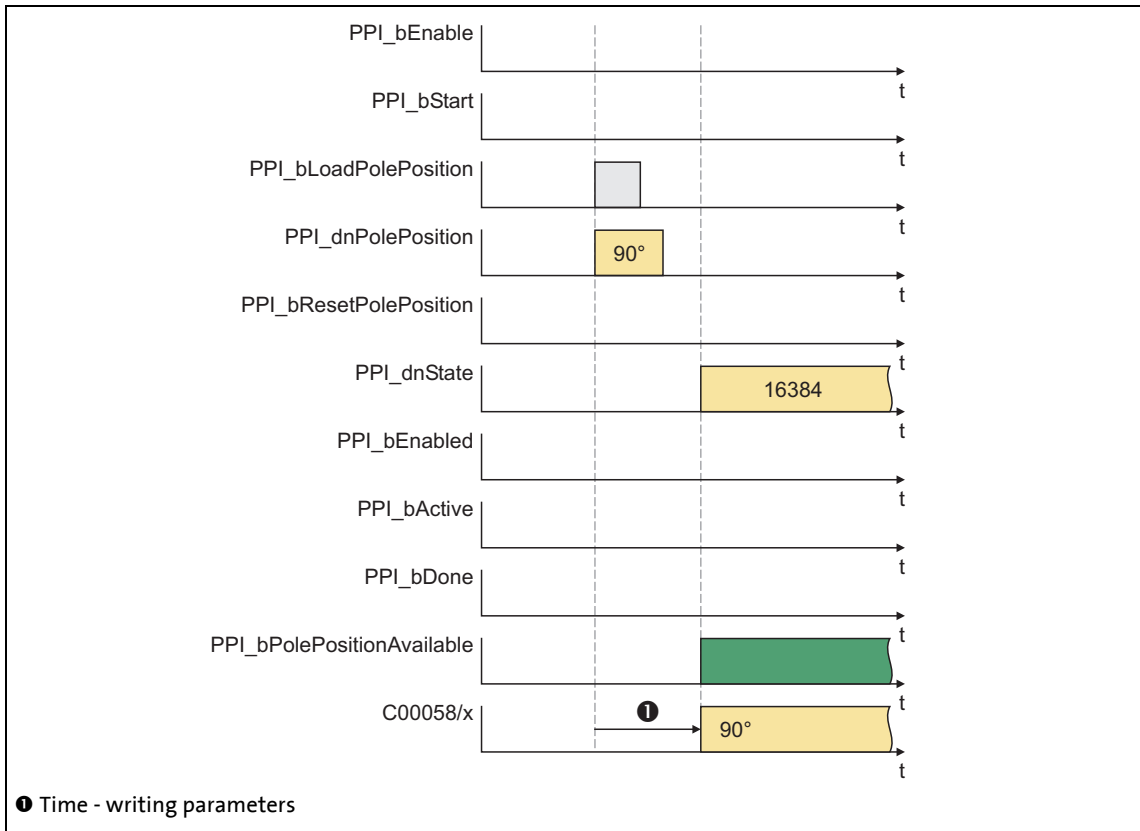

[11-55] Signal characteristic 2: Load pole position

# 11 Basic drive functions

## 11.14 Pole position identification



[11-56] Signal characteristic 3: Reset pole position

### 11.14.5 Deactivating a known pole position

The following describes the circumstances that cause a deactivation of an already known pole position by changing certain parameter settings. The pole position status *PPI\_bPolePositionAvailable* changes from TRUE to FALSE due to the change.

#### Changing the type of motor control (C00006)

Initial situation	Parameter change
<ul style="list-style-type: none"> <li>• <i>PPI_bPolePositionAvailable</i> = TRUE</li> <li>• Motor control (C00006) =               <ul style="list-style-type: none"> <li>• "2: SC: Servo control async. motor" or</li> <li>• "4: SLVC: Sensorless vector control" or</li> <li>• "6: VFCplus: V/f control" or</li> <li>• "7: VFCplus: V/f control"</li> </ul> </li> </ul>	In C00006, the motor control "1: SC: Servo control sync. motor" is set.

#### Changing relevant motor data

Initial situation	Parameter change
<i>PPI_bPolePositionAvailable</i> = TRUE	One of the following parameters is changed: <ul style="list-style-type: none"> <li>• Rated motor speed (C00087)</li> <li>• Rated motor frequency (C00089)</li> <li>• Rated motor voltage (C00090)</li> </ul>

#### Changing relevant encoder data

Initial situation	Parameter change
<i>PPI_bPolePositionAvailable</i> = TRUE	One of the following parameters is changed: <ul style="list-style-type: none"> <li>• Resolver - number of pole pairs (C00080)</li> <li>• Encoder - number of increments (C00420)</li> <li>• Encoder type (C00422)</li> <li>• TTL encoder signal evaluation (C00427)</li> <li>• Motor encoder selection (C00495)</li> </ul>

#### Behaviour after mains ON

Initial situation 1	Behaviour after mains ON
<ul style="list-style-type: none"> <li>• <i>PPI_bPolePositionAvailable</i> = TRUE</li> <li>• Motor control (C00006) = "1: SC: Servo control sync. motor"</li> <li>• Resolver - number of pole pairs (C00080) &gt; 1</li> </ul>	<i>PPI_bPolePositionAvailable</i> is only reset to FALSE if: <ul style="list-style-type: none"> <li>• Motor encoder selection (C00495) = "0: Resolver to X7"</li> </ul> <b>AND</b> <ul style="list-style-type: none"> <li>• The number of motor pole pairs are (C00059no integer multiple of the number of resolver pole pairs (C00080).</li> </ul>

Initial situation 2	Behaviour after mains ON
<ul style="list-style-type: none"> <li>• <i>PPI_bPolePositionAvailable</i> = TRUE</li> <li>• Motor control (C00006) = "1: SC: Servo control sync. motor"</li> <li>• Encoder type (C00422) =               <ul style="list-style-type: none"> <li>• "0: Incremental encoder (TTL signal)" or</li> <li>• "1: Sine/Cosine encoder"</li> </ul> </li> <li>• Motor encoder selection (C00495) = "1: Encoder to X8"</li> </ul>	<i>PPI_bPolePositionAvailable</i> is reset to FALSE.

**Behaviour after encoder error**

Initial situation	Behaviour after encoder error
<ul style="list-style-type: none"> <li>• <i>PPI_bPolePositionAvailable</i> = TRUE</li> <li>• Motor control (C00006) = "1: SC: Servo control sync. motor"</li> <li>• Encoder type (C00422) = <ul style="list-style-type: none"> <li>• "0: Incremental encoder (TTL signal)" or</li> <li>• "1: Sine/Cosine encoder" or</li> <li>• "2: Absolute value encoder (Hiperface)" or</li> <li>• "3: Absolute value encoder (EnDat)" or</li> </ul> </li> <li>• Motor encoder selection (C00495) = "1: Encoder to X8"</li> </ul>	<p><i>PPI_bPolePositionAvailable</i> is reset to FALSE.</p>

**Behaviour after resolver error**

Initial situation	Behaviour after resolver error
<ul style="list-style-type: none"> <li>• <i>PPI_bPolePositionAvailable</i> = TRUE</li> <li>• Motor control (C00006) = "1: SC: Servo control sync. motor"</li> <li>• The number of motor pole pairs are (C00059no integer multiple of the number of resolver pole pairs (C00080).</li> <li>• Motor encoder selection (C00495) = "0: Resolver to X7"</li> </ul>	<p><i>PPI_bPolePositionAvailable</i> is reset to FALSE.</p>



## 12 Oscilloscope

The oscilloscope function integrated in the Servo Drives 9400 HighLine can be used as support for commissioning, maintenance and troubleshooting. The oscilloscope function is operated via a user interface in the engineering tool.

### Typical applications

- Graphic display of measured variable (e.g. speed setpoint, actual speed value and torque)
- Detection of process values without additional measuring instruments (e.g. oscilloscope, voltmeter and ammeter)
- Convenient documentation for fine tuning of control circuits or parameter changes of the Servo Drives 9400 HighLine

### Special features

- Recording and saving measured values in the Servo Drives 9400 HighLine
- Simultaneous measuring on eight independent channels
- Measuring fast and slow signals by means of adjustable sample rate
- Triggering on channel, variable or system event
- Detecting measured values before and after the trigger event
- Transferring measured values to the Engineering PC for the purpose of graphic display and evaluation in the engineering tool
- The measured values represented in the form of curves can be optionally shown and hidden, represented in any colour or overlaid with the signal characteristic of other variables recorded.
- Cursor and zoom function for the measurement analysis
- Saving & loading oscilloscope configurations on the Engineering PC
- Export of measured values via the clipboard for further processing
- Linking channel values with arithmetic operations (addition, subtraction and multiplication)
- Simple signal analysis by frequency transformation of time signals with FFT ("Fast Fourier Transformation").

### 12.1 Functional description

When an online connection to the Servo Drives 9400 HighLine has been established, use the oscilloscope user interface of the engineering tool to set the trigger condition and the sample rate and select the signal sources to be recorded. Here, "signal sources" are the internal output signals of the function, system, application and port blocks.

The values are validated after each input acknowledgement by the "Return" key. If the check shows invalid settings, the oscilloscope triggers an error.

With an online connection, the measured values contained in the Servo Drives 9400 HighLine are transferred to the engineering tool and graphically presented on the oscilloscope user interface as soon as the measurement has been completed.

### 12.2 Technical data

Oscilloscope function of Servo Drives 9400 HighLine	
Number of channels	1 ... 8
Depth of the measured value memory	Max. 16384 measured values, depending on the number of channels and the size of the variables to be recorded.
Data width of a channel	1 ... 4 bytes, corresponding to the size of the variables to be recorded
Sampling rate	1 ms or a multiple of it. Increased sampling rates of 62.5 $\mu$ s or 250 $\mu$ s are possible.
Max. time base	8 channels 32 bits each $\equiv$ 26 hours
Max. recording time	8 channels 32 bits each $\equiv$ 10 days
Memory capacity	32768 bytes
Trigger level	Corresponding to the value range of the signal sources to be triggered
Trigger selection	Immediate triggering, rising/falling edge, signal change
Trigger delay	-100 % ... +400 %
Trigger source	Channel 1 ... 8: <ul style="list-style-type: none"> <li>• Any application variable</li> <li>• Motor control variables</li> <li>• System events</li> <li>• Internal variables</li> </ul>

### 12.3 Operation

This chapter informs you step by step on how to record signal characteristics of variables in the Servo Drives 9400 HighLine using the oscilloscope and then present, analyse, document and process them in the oscilloscope.

**Note!**

The configuration of the oscilloscope and the start of recording are only possible when an online connection has been established to the Servo Drives 9400 HighLine.

### 12.3.1 User interface

The oscilloscope user interface is available in the following Lenze engineering tools:

<input checked="" type="checkbox"/> »Engineer« from version 2.16	<input type="checkbox"/> »PLC Designer«	<input checked="" type="checkbox"/> »EASY Starter« from version 1.9
--	---	---



#### How to go to the oscilloscope user interface:

1. Go to the *Project view* and select the Servo Drives 9400 HighLine.
2. Select the **Oscilloscope** tab from the *Workspace*.

The oscilloscope user interface contains the following control and function elements:

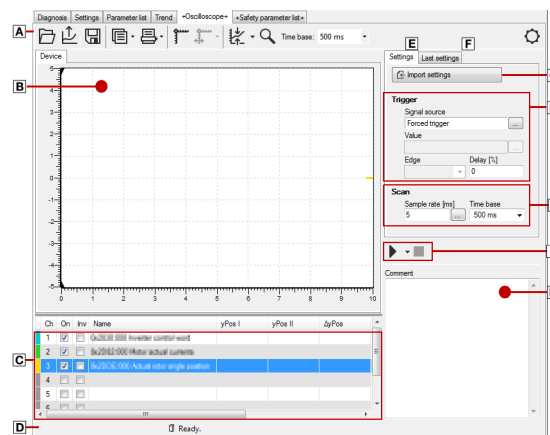

A [Oscilloscope toolbar](#)

B [Oscillogram selection](#)

C Channel list  
 ▶ [Selecting the signal sources to be recorded](#)

D Status bar

E Recruitment

F Last settings

G [Import settings from a loaded oscillogram or an oscillogram file](#)













H [Trigger settings](#)

I Input fields for  
 ▶ [Selecting the recording time/sample rate](#)

J [Start recording / stop](#)

: Input field for [comments](#)

**Oscilloscope toolbar**

Symbol	Job title
	<a href="#">Loading the oscillogram file</a> (📖 601)
	Upload recorded oscillogram from device <ul style="list-style-type: none"> <li>• Transmit values from the measured value memory of the Servo Drives 9400 HighLine to the Engineering PC.</li> <li>• Only possible when an online connection has been established to the Servo Drives 9400 HighLine.</li> </ul>
	<a href="#">Saving the oscillogram in a file</a> (📖 600)
	Copy to clipboard: Copy as text   Copy as picture   Copy as table   Copy as raw value <ul style="list-style-type: none"> <li>• For documentation purposes, it is possible to copy the measured value of an oscilloscope as a table or, alternatively, the oscilloscope user interface as a picture, to the clipboard for use in other programs.</li> </ul>
	Printer settings   Print view   Print
	Activate zoom function ▶ <a href="#">Adjusting the representation</a> (📖 596)
	Show cursor
	Automatically scale vertically <ul style="list-style-type: none"> <li>• Set all Y positions to zero</li> <li>• Arrange all curves above one another: The Y positions are evenly distributed over the entire vertical range.</li> </ul>
	Activate zoom function ▶ <a href="#">Adjusting the representation</a> (📖 596)
	<a href="#">Start recording</a> (📖 595) <ul style="list-style-type: none"> <li>• Transfer settings to the device</li> <li>• Activate trigger</li> </ul>
	Stop recording
	Oscilloscope settings <ul style="list-style-type: none"> <li>• <a href="#">Cyclic recording of oscillograms</a></li> <li>• Always load oscillograms after recording is completed without a query</li> </ul>

### 12.3.2 Selecting the signal sources to be recorded

The oscilloscope supports up to eight channels. Thus, the **channel list** can record maximally eight signal sources.

Use the **channel list** to configure the signal sources to be recorded:

Ch	On	Inv	Name	Context	yPos I	yPos II	▲  ΔyPos	Unit	AS	1/Div	Offset	Position
1	<input checked="" type="checkbox"/>	<input type="checkbox"/>	Voltage.dnActualMotorVoltage					V	<input checked="" type="checkbox"/>	100	0	0
2	<input checked="" type="checkbox"/>	<input type="checkbox"/>	Voltage.dnMotorVoltageLimit					V	<input checked="" type="checkbox"/>	100	0	0
3	<input checked="" type="checkbox"/>	<input type="checkbox"/>	Current.dnActualDirectCurrent					A	<input checked="" type="checkbox"/>	100	0	0
4	<input checked="" type="checkbox"/>	<input type="checkbox"/>	Torque.dnActualMotorTorque					Nm	<input checked="" type="checkbox"/>	100	0	0
5	<input checked="" type="checkbox"/>	<input type="checkbox"/>	Speed.dnActualMotorSpeed					rpm	<input checked="" type="checkbox"/>	100	0	0
6	<input checked="" type="checkbox"/>	<input checked="" type="checkbox"/>	Speed.dnOutputPosCtrlMotor					rpm	<input checked="" type="checkbox"/>	100	0	0
7	<input type="checkbox"/>	<input type="checkbox"/>							<input type="checkbox"/>			
8	<input type="checkbox"/>	<input type="checkbox"/>							<input type="checkbox"/>			

Designation	Meaning
-	Curve colour for representation in the oscillogram • A double-click on the colour area of the channel serves to set a user-defined colour.
Ch	Channel number
To	Cam visible / invisible
Inv	Inversion yes / no
Name	Name of the signal source
Context	Channel representation with task reference • Channel representation with task selection: • If the selected task is <b>active</b> at the time of recording, the value is taken from the input image of the selected task. • If the selected task is <b>not active</b> at the time of recording, an invalid value is recorded. There will be a gap in the graph. • Channel representation without task selection: • The current value of the variables is used without task reference at the time of recording.
yPos I	y position of cursor I
yPos II	y position of cursor II
ΔyPos	Difference of the y positions of both cursors • Difference = yPos II - yPos I
Unit	Unit of the signal source
AS	Select/deselect channel for automatic scaling
1/Div	Vertical scaling factor
Offset	Offset value • The offset value is subtracted from the recorded raw value before scaling is executed. This serves, for instance, to make very slight value fluctuations visible within one constantly very high recording value (e.g. harmonics with low amplitude).
Position	Position value • The position value determines the vertical position of the zero point of the y axis of a curve with regard to the vertical curve scale (- 5 ... + 5).

**How to select a signal source for recording:**

1. Double-click a non-assigned line in the **channel list** to open the *Select signal source* dialog box.
  - Double-clicking an already pre-assigned selection enables you to assign it with another signal source.
2. Select a new variable in the *Select signal source* dialog box.
3. Click the **OK** button.
  - The dialog box is closed and the selection is accepted.

**How to delete a selection:**

1. Go to the **channel list** and click the signal source to be removed.
2. Right-click the *context menu* to open it.
3. Select the **Delete signal source** command in the *context menu*.

You can add so many signal sources for the recording until all eight channels are assigned.

### 12.3.3 Selecting the recording time/sample rate



**How to select the recording time and the sample rate:**

1. Select the desired time base from the **time base** list field.
  - The current time base setting multiplied by ten results in the recording time.
  - Since the measured data memory of the Servo Drives 9400 HighLine has a limited capacity, usually a compromise is made between sample rate and recording time.
2. Enter the desired sampling rate in [ms] in the **sampling rate** input field.

Pressing the " ..." button next to the **Sampling rate** input field opens the *Sampling rate* dialog box. Here, you can also select the option **Increased sampling rate**:

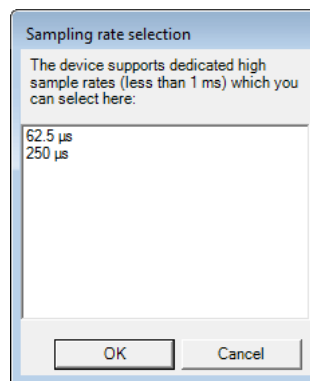

#### Note!

When the option **Increased sampling rate** is selected, only integer multiples of  $1/(\text{sampling rate in ms})$  are detected by the system.

- Since a complete representation in the oscillogram ( $10 * 1/(\text{sampling rate in ms}) * (\text{horizontal resolution in ms/Div})$ ) requires + 1 measured values, but due to system-dependent reasons only integer multiples of  $(1 / (\text{sampling rate in ms}))$  can be recorded, 1 ... 3 measured values may be missing at the left or right edges of the oscillogram. The displayed curve then ends before the end or starts after the start of the oscillogram.
- The curve that is recorded is not extended or compressed.



### 12.3.4 Selecting the trigger condition

Use the trigger condition to define when recording should start in the Servo Drives 9400 HighLine. The oscilloscope offers various trigger conditions for controlling how the measured values are recorded.



If the **Last settings** tab is in the foreground, click the **Settings** tab to show the input fields for configuring the trigger condition. The **Settings** tab contains the **Import settings** button for importing settings from a loaded oscillogram.

setting	Job title
<b>Signal source</b>	Selection of the trigger source
Variable	Selection of an application variable or a motor control variable as signal source
Channel	The oscilloscope triggers on a channel configured in the <b>channel list</b> .
System event	The following system events serve as trigger source: <ul style="list-style-type: none"> <li>• Fault</li> <li>• Warning</li> <li>• Error</li> <li>• Quick stop by trouble</li> <li>• Any system event</li> </ul>
Direct trigger	No trigger condition. Recording commences as soon as you press the <b>Start recording</b> button, if <b>Activate trigger</b> has been activated in the dropdown menu.
<b>Value</b>	Value from which on triggering is activated.
<b>Deceleration</b>	Time delay between recording and trigger event. Unit: [%]
Trigger delay	To detect signals that occur <b>before</b> the trigger event (e.g. values responsible for causing the event), enter a negative delay time. <div style="text-align: center;"> </div> <p>In the oscillograph, the trigger time is marked by a dotted line. If you set a negative trigger delay, make sure that the recording memory contains the required values at the time of the trigger event. To ensure this, the settings must be transferred to the device far enough in advance of the trigger event.</p> <p>To detect signals that occur a certain time <b>after</b> the trigger event, enter a positive delay time.</p> <div style="text-align: center;"> </div>

setting	Job title
<b>Edge</b>	Three trigger types are available:
Positive edge	First, the selected trigger value must be fallen below and then exceeded in order that the trigger is activated.
Negative edge	First, the selected trigger value must be exceeded and then fallen below in order that the trigger is activated.
Change	For triggering on a Boolean signal source: <ul style="list-style-type: none"> <li>• Trigger activation requires a state change.</li> </ul> For triggering on a different signal source: <ul style="list-style-type: none"> <li>• The current value must be different than the last value in order that the trigger is activated.</li> </ul>

### 12.3.5 Start recording

The following options are available in the dropdown menu:

- **Transfer settings to the device**
  - All oscilloscope settings are written to the device.
- **Activate trigger**
  - Actual recording from the device is only enabled if this option is activated.
  - The **Oscilloscope** tab displays the recording.

When you press the **Start recording**  button, only the actions that have been activated in the dropdown menu (signalled by a checkmark) will be executed.

- With the engineering tool default setting, both options are active. When you press the **Start recording**  button, both actions will be executed one after the other.
- There is always at least one active option.

#### Start recording after the trigger or scan settings are changed

If the trigger or scan settings have been changed on the **Oscilloscope** tab, an exclamation mark will appear on the **Start recording** button:



After the configuration has been changed, it is transferred to the device by opening the dropdown menu and activating **Transfer settings to the device**.

### 12.3.6 Cyclic recording



#### How to record oscillogram cyclically:

1. Click the  icon in the *oscilloscope toolbar* to open the **Oscilloscope settings** dialog box [▶ Oscilloscope toolbar](#) (📖 589).
2. In order that the recording process is restarted automatically after the upload of an oscillogram, set the checkmark accordingly.
  - Cyclic recording is only possible for time base values  $\geq 500$  ms.

For monitoring certain situations, this serves, for instance, to obtain the increased view of the interesting part of a characteristic even after the cyclic update, as originally zoomed.

### 12.3.7 Adjusting the representation







After the variable values have been recorded and the oscillogram has been transferred to the PC, it is visualised. If required, the representation can now be adjusted by using the zoom or the automatic scaling function.

#### Zoom function

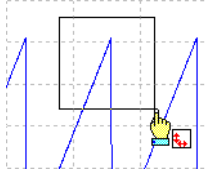

Go to the *oscilloscope toolbar* and click the  icon to activate the zoom function

► [Oscilloscope toolbar](#) (p. 589)

Zoom function	Procedure	
Zoom selection		Hold down the left mouse button and draw the oscillogram section to be zoomed:  <ul style="list-style-type: none"> <li>• While being drawn, the selection is shown with a frame.</li> <li>• When the left mouse button is released, the selection is zoomed in the oscillogram.</li> </ul>
Horizontal stretching		Hold down the left mouse button and move the mouse pointer on the horizontal scale to the left to stretch the shown selection from the right edge.
		Hold down the right mouse button and move the mouse pointer on the horizontal scale to the right to stretch the shown selection from the left edge.
Moving the mouse pointer in opposite direction continuously reduces the stretching.		
Vertical stretching		Hold down the left mouse button and move the mouse pointer on the vertical scale to the bottom to stretch the shown selection from the top.
		Hold down the right mouse button and move the mouse pointer on the vertical scale to the top to stretch the shown selection from the bottom.
Moving the mouse pointer in opposite direction continuously reduces the stretching.		
Return to original representation		Click the right mouse button in the oscillogram to return step by step to the original representation.

#### Automatic scaling function

Use the automatic scaling function to automatically scale and reposition the representation of selectable signal characteristics in the oscillogram and reset the offset to "0".



**How to carry out automatic scaling:**

1. Activate the automatic scaling for each channel in the **channel list** by a checkmark in the "AS" column.
2. Go to the *oscilloscope toolbar* and click the  icon to activate the automatic scaling function for the activated channels.

3. Click the **OK** button.
  - The dialog box is closed and the selected channels/signal sources are scaled automatically.
4. Go to the *oscilloscope toolbar* and click the arrow next to the  symbol to set all the displayed curves to the Y position "0". This way, the curves are displayed "above one another".



#### How to carry out scaling manually per channel:

1. Go to the **Channel list** and click the entry to be changed in the "Unit" column (double-clicking an empty line has no effect.)
  - The dialog for entering the scaling opens which, as can be seen here in the example, allows for the entry of the lower and upper limit and the unit:

2. Enter the lower limit, the upper limit and the unit.
  - On the right side, any scaling values can be entered as upper and lower limit.
  - On the left side of the dialog, the limits of the data type of the recorded value are displayed.
3. Click the **OK** button.
  - The dialog box is closed.

There are variables the scaling of which depends on a parameter setting at the recording time (e.g. [C00100](#)). For these variables, the "Update scaling after oscillogram upload" option can be selected in the "Scaling" dialog.

If this option is active (box checked), the scaling settings "lower limit" and "upper limit" are automatically reset in the device according to the respective parameter value (e.g. [C00100](#)) each time an oscillogram is uploaded.



The option is automatically deactivated as soon as a value has been entered manually into the "lower limit" or "upper limit" field - the box is unchecked in the option.

### 12.3.8 Cursor function: Reading individual measured values

In addition to the zoom and scaling function, the oscilloscope offers a "cursor function" that can be used to display individual measured values of a selectable channel or the difference between two measured values.



#### How to use the cursor function:

1. Go to the *oscilloscope toolbar* and click the  icon to activate the cursor function.
  - Another  button is then shown which enables the centering of two independent and movable measuring lines.
  - The status bar displays the position of both measuring lines and the difference between them.
2. Select the channel for which individual measured values are to be indicated from the **Channel** list field.
3. Hold down the left mouse button and drag the red vertical measuring line to the desired position.
  - The active measuring line is represented by a continuous line, the inactive measuring line is represented by a dashed line.
  - If you click the inactive measuring line, it automatically becomes active.
  - The value measured at the position of the active measuring line is indicated in the value group box.
  - The difference between the values measured at the two measuring lines is indicated in the Differential value group field.
  - Comparing peak values: Several values displayed in the oscillogram can be compared by means of a horizontal measuring line. This measuring line is automatically generated based on the current cursor position and thus cannot be moved separately.

### 12.3.9 Last settings

All information included in the **Last settings** tab refer to the oscillogram loaded into the device:

The screenshot shows a window titled "Last settings" with the following content:

- Uploaded from device: -
- Trigger**
  - Signal source: -
  - Value: -
  - Edge: -
  - Delay: -
- Scan**
  - Sample rate: -
  - Time base: -

The contents cannot be changed.

## 12.4 Managing oscillograms (measured data records)

If several oscillograms are loaded in the oscilloscope at the same time, the oscillogram to be displayed is selected via the corresponding tab below the toolbar. In general, the following oscillograms are to be distinguished:

### Device oscillogram

The device oscillogram is the only oscillogram which can be used to establish a connection to the target system to carry out an oscilloscope measurement.

### MERGE oscillogram

If two or more oscillograms are loaded in the oscilloscope, a "MERGE" tab is available.

- In the merge tab, several characteristics from the currently loaded data records can be overlaid, e.g. to compare signal characteristics from different recordings. ▶ [Overlay function](#) (📖 603)

### Loaded oscillogram

An oscillogram loaded from a file.

### 12.4.1 Commenting the oscillogram

The **Comments** text field serves to enter a comment on the selected oscillogram.

- If you execute the [Saving the oscillogram in a file](#) command, the comment is saved together with the oscillogram in the file.

### 12.4.2 Saving the oscillogram in a file

After the signal sources to be recorded have been selected and the required settings have been entered, you can save the configuration and recording, if already executed, for future use in the project or export them to a file.



#### Note!

The reuse of a saved configuration is only reasonable for devices of the same type, as otherwise due to a scaling of the oscilloscope channels that is not adapted, incorrect values are displayed!



#### How to save an oscillogram in the project:

1. Click the  icon in the *oscilloscope toolbar*.
  - The *Open oscillogram file* dialog box is displayed.
2. Specify a file name in the **File name** input field.
3. Click the **Filing in the project** button.
  - The dialog box is closed and the current oscillogram is filed in the project.



#### Note!

The oscillogram is only saved if the entire project is saved!



#### How to save an oscillogram as external file:

1. Click the  icon in the *oscilloscope toolbar*.
  - The *Open oscillogram file* dialog box is displayed.
2. Press the **Save as external file ...** button.
  - A new window opens in which the directory and the file name for the oscillogram to be saved have to be specified.
3. Click the **Save** button.
  - The dialog box is closed and the current oscillogram is saved.



### 12.4.3 Loading the oscillogram file

Configurations/oscillograms already saved can be reloaded into the oscilloscope any time, e.g. for the overlay function.



#### Note!

The reuse of a saved configuration is only possible for devices of the same type, as otherwise due to a scaling of the oscilloscope channels that is not adapted, incorrect values are displayed!



#### How to load an oscillogram file from the project:

1. Click the  icon in the *oscilloscope toolbar*.
  - The *Load oscillogram file* dialog box appears.
2. Select the file to be loaded from the upper list field.
3. Click the **OK** button.
  - The dialog box is closed and the oscillogram file is accepted.



#### How to load an oscillogram file from an external file:

1. Click the  icon in the *oscilloscope toolbar*.
  - The *Load oscillogram file* dialog box appears.
2. Press the **Load from external file...** button.
  - A new window opens in which the directory and the file name for the oscillogram file to be loaded have to be selected.
3. Click **Open**.
  - The dialog box is closed and the oscillogram file is loaded.
  - The oscillogram is displayed on an additionally appearing tab.
  - If the configuration to be loaded contains signal sources that are no longer available in the device, these variables are automatically removed from the configuration.

#### 12.4.4 Importing settings from another loaded oscillogram

Pressing the **Import settings** button opens a dialog box containing the following possible settings:

- Select an oscillogram for importing the settings
  - By default, the settings from the oscillograms currently loaded in the oscilloscope are provided.
- Select the oscillogram file of the project to import the settings

*This setting is only available for the »Engineer« from version 2.16 onwards!*

  - One or several oscillogram files saved in the project (\*.los) are provided. Their file name and the time of upload from the device are given.
- Import oscillogram settings from oscillogram file
  - You can navigate to the respective oscillogram file on the file level of the PC by pressing the "..." button under this menu item.

### 12.4.5 Overlay function

The overlay function serves to lay several characteristics from the currently loaded oscillogram files on top of each other, e.g. to compare signal characteristics from different recordings.

- If two or more oscillograms are loaded in the oscilloscope, e.g. the device oscillogram and an oscillogram previously saved in the project, a "MERGE" tab is available.
- If the MERGE tab is selected, the desired characteristics to be overload or compared can be selected from the loaded files in the **channel list**.
- If a device oscillogram is used in the merge tab, an update is carried out in the MERGE oscillogram in case of a renewed recording.
- Removing signal sources from the device oscillogram causes the characteristics in the MERGE oscillogram to be deleted.

### 12.4.6 Deleting an oscillogram file saved in the project



How to delete an oscillogram file saved in the project:

1. Click the  icon in the *oscilloscope toolbar*.
  - The *Load oscillogram file* dialog box appears.

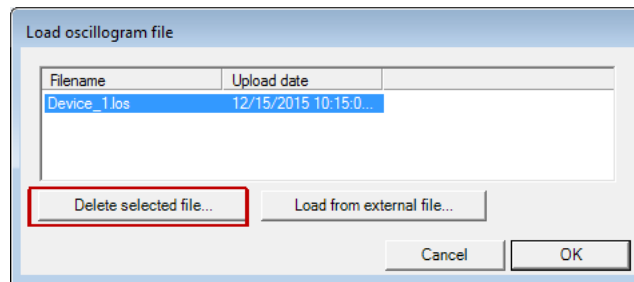

2. Select one or several oscillogram files from the upper list field.
3. Press the **Delete selected file...** button.
  - The selected file(s) is/are deleted and the dialog box is closed.

## 12.5 Variables of the motor control (oscilloscope signals)

The system variables of the internal motor control listed in the following table can be recorded with the oscilloscope for diagnostic and documentation purposes.



### Note!

In comparison to all other variable values, the system variables of the internal motor control have a cycle offset of 2 ... 3 ms!



### Tip!

The exact position of a variable in the motor control can be obtained from the corresponding signal flow.

Variable of the motor control	Meaning
<a href="#">▶ Signal flow - servo control for synchronous motor (162)</a> <a href="#">▶ Signal flow - servo control for asynchronous motor (164)</a>	
Common.dnActualFlux	Actual flux value
Common.dnFluxSet	Flux setpoint
Current.dnActualCurrentPhaseU	Actual motor current (phase U)
Current.dnActualCurrentPhaseV	Actual motor current (phase V)
Current.dnActualCurrentPhaseW	Actual motor current (phase W)
Current.dnActualDirectCurrent	Actual D current
Current.dnActualQuadratureCurrent	Actual Q current
Current.dnDirectCurrentSet	D current setpoint
Current.dnQuadratureCurrentSet	Q current setpoint
Torque.dnActualMotorTorque	Actual torque
Torque.dnFilteredTorqueSetpoint	Filtered torque setpoint
Torque.dnInputNotchFilter1	Torque setpoint at the band-stop filter input 1
Torque.dnInputNotchFilter2	Torque setpoint at the band-stop filter 2 input
Voltage.dnActualDCBusVoltage	Current DC-bus voltage
Voltage.dnActualMotorVoltage	Current motor voltage
Voltage.dnOutputQuadratureCurrentCtrl	Q-output voltage of the current controller
Voltage.dnOutputDirectCurrentCtrl	D-output voltage of the current controller
Voltage.dnDirectVoltage	D voltage
Voltage.dnQuadratureVoltage	Q voltage

Variable of the motor control		Meaning
▶ <a href="#">Signal flow - sensorless vector control</a> (📖 183)		
	Common.dnActualFlux	Actual flux value
	Current.dnActualDirectCurrent	Actual D current
	Current.dnActualQuadratureCurrent	Actual Q current
	Current.dnDirectCurrentSet	D current setpoint
	Current.dnQuadratureCurrentSet	Q current setpoint
	Frequency.dnActualRotatingFieldFrequency	Current field frequency
	Frequency.dnActualSlipFrequency	Actual slip frequency
	Speed.dnActualMotorSpeed	Actual speed value
	Torque.dnTorqueSetpoint	Torque setpoint
	Voltage.dnActualMotorVoltage	Current motor voltage
	Voltage.dnDirectVoltage	D voltage
	Voltage.dnQuadratureVoltage	Q voltage
▶ <a href="#">Signal flow - V/f control</a> (📖 199)		
▶ <a href="#">Signal flow for closed loop V/f control</a> (📖 201)		
	Current.Current.dnActualMotorCurrent	Actual motor current
	Current.dnActualQuadratureCurrent	Actual Q current
	Frequency.dnActualRotatingFieldFrequency	Current field frequency
	Frequency.dnActualSlipFrequency	Actual slip frequency
	Speed.dnActualMotorSpeed	Current motor speed
	Speed.dnSpeedSetpoint	Speed setpoint
	Voltage.dnActualMotorVoltage	Current motor voltage
	Voltage.dnOutputDirectCurrentCtrl	D voltage
	Voltage.dnOutputQuadratureVoltage	Q voltage
▶ <a href="#">Signal flow - encoder evaluation</a> (📖 243)		
	Position.dnActualLoadPos	Actual position
	Position.dnActualMotorPos	Current motor position
	Speed.dnActualEncoderSpeed	Current encoder speed
	Speed.dnActualMotorSpeed	Current motor speed
	Speed.dnActualResolverSpeed	Current resolver speed
▶ <a href="#">Signal flow - position follower</a> (📖 492)		
	Position.dnActualLoadPos	Actual position
	Position.dnActualMotorPos	Current motor position
	Position.dnContouringError	Following error
	Position.dnPositionSetpoint	Position setpoint
	Speed.dnActualMotorSpeed	Current motor speed
	Speed.dnOutputPosCtrl	Output signal - phase controller
	Speed.dnSpeedSetpoint	Speed setpoint
	Torque.dnTorqueSetpoint	Torque setpoint
	Torque.dnTotalTorqueAdd	Additive torque feedforward control value

Variable of the motor control		Meaning
▶ <a href="#">Signal flow - speed follower</a> (📖 498)		
	Speed.dnActualMotorSpeed	Current motor speed
	Speed.dnSpeedSetpoint	Speed setpoint
	Speed.dnTotalSpeedAdd	Additive speed setpoint
	Torque.dnTorqueSetpoint	Torque setpoint
	Torque.dnTotalTorqueAdd	Additive torque feedforward control value
▶ <a href="#">Signal flow - torque follower</a> (📖 503)		
	Speed.dnActualMotorSpeed	Current motor speed
	Speed.dnSpeedSetpoint	Speed setpoint

# 13 Diagnostics & fault analysis

## 13.1 LED status display

# 13 Diagnostics & fault analysis

## 13.1 LED status display

Information on some operating states can be quickly obtained via LED displays:

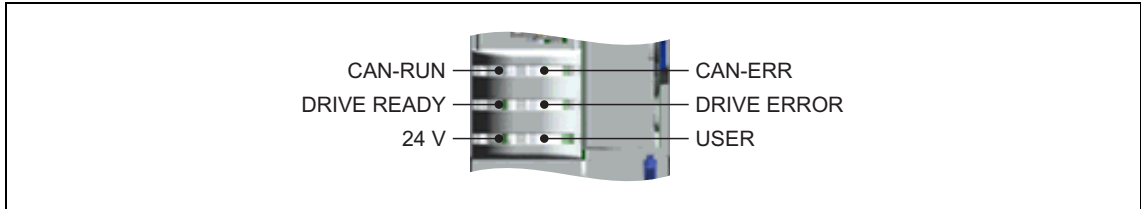

[13-1] LED display on the controller front panel

Labelling	Colour	Description
CAN-RUN	green	CAN bus ok
CAN-ERR	red	CAN bus error
DRIVE READY	green	Standard device ready for operation
DRIVE ERROR	red	Warning/trouble/fault
24 V	green	24-V supply voltage ok
USER	yellow	Message parameterised by the application



### 13.1.1 LED status displays for the device state

The control of the two LEDs "DRIVE READY" and "DRIVE ERROR" in the middle of the controller's front panel depends on the device state. ▶ [Device states](#) (100)

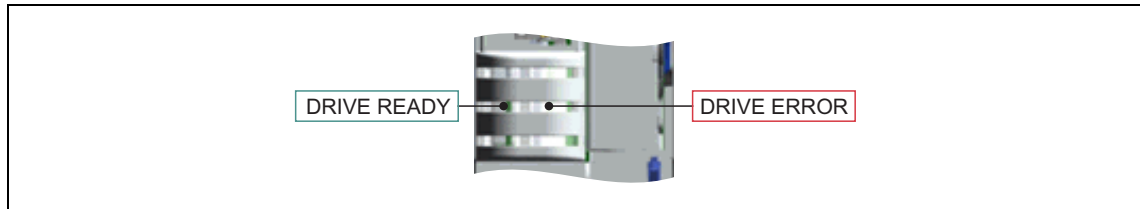

[13-2] DRIVE READY and DRIVE ERROR LED status displays

The meaning can be seen from the table below:

DRIVE READY	DRIVE ERROR	Meaning
OFF	OFF	<a href="#">"Initialisation active" state</a>
	OFF	<a href="#">"Safe torque off active" state</a> Observe LED on the safety module!
	OFF	<a href="#">"Device is ready to switch on" state</a>
	OFF	<a href="#">"Device is switched on" state</a>
	OFF	<a href="#">"Operation" state</a>
  		<a href="#">"Warning active" or "Warning locked active"</a> The controller is ready to switch on, switched on or the operation is enabled and a warning is indicated.
		<a href="#">"Quick stop by trouble active" state</a>
OFF		<a href="#">"Trouble active" state</a>
OFF		<a href="#">"Fault active" state</a>
OFF		<a href="#">"System fault active" state</a>
<b>Legend</b>		
Meaning of the symbols used to describe the LED states:		
	LED is flashing once approx. every 3 seconds ( <i>slow flash</i> )	
	LED is flashing twice approx. every 1.25 seconds ( <i>flash</i> )	
	LED is flashing twice approx. every 1.25 seconds ( <i>double flash</i> )	
	LED is blinking every second	
	LED is permanently on	

### 13.2 Drive diagnostics with the »Engineer«

When an online connection to the controller has been established, the connected controller can be diagnosed and relevant actual controller states can be displayed in a clearly arranged visualisation using the »Engineer«.





#### How to diagnose a drive with the »Engineer«:

1. Select the 9400 HighLine controller to be diagnosed in the *Project view*.
2. Click the  icon or select the **Online→Go online** command to build up an online connection with the controller.
3. Select the **Diagnostics** tab.

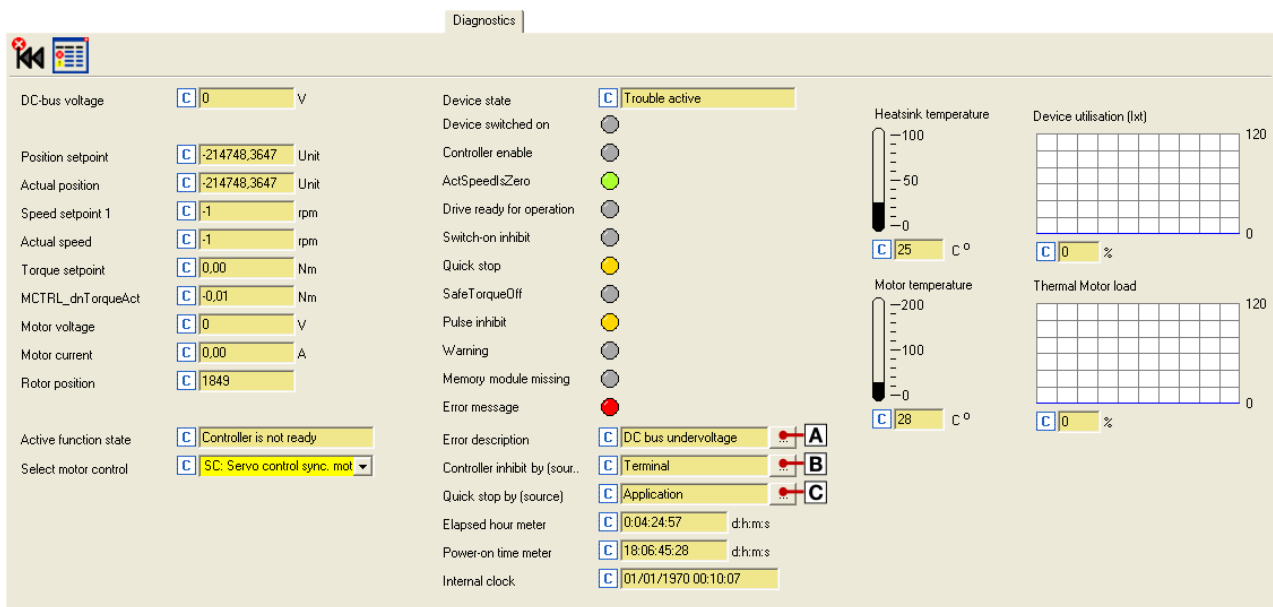
With an online connection, the **Diagnostics** tab displays current status information about the controller:



Button	Job title
	Acknowledge error message (if the error cause has been eliminated).
	<a href="#">Reading out logbook entries</a> (📖 615)
	<b>A</b> Display details of the current error.
	<b>B</b> Display all active sources of a controller inhibit.
	<b>C</b> Display all active sources of a quick stop.

### 13.3 Drive diagnostics via keypad/bus system

#### Keypad display of the controller status

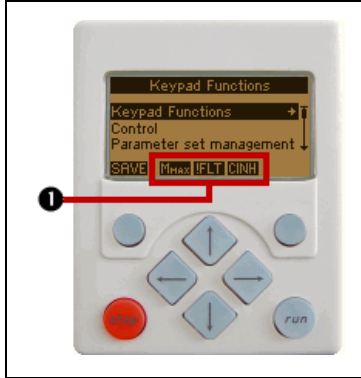

- If the keypad on the front of the controller is connected to the diagnostic interface X6, the status of the controller is shown via different icons on the LCD display in the area ❶.

Symbol	Meaning	Note
<b>RDY</b>	Controller is ready for operation.	
<b>RUN</b>	Controller is enabled.	
<b>STP</b>	Application in the controller is stopped.	
<b>QSP</b>	Quick stop active	
<b>CINH</b>	Controller is inhibited.	The power outputs are inhibited.
<b>OFF</b>	Controller is ready to start.	
<b>Mmax</b>	Speed controller 1 at the limit.	The drive is torque-controlled.
<b>I<sub>max</sub></b>	Set current limit has been exceeded in motor or generator mode.	
<b>IMP</b>	Pulse inhibit active	The power outputs are inhibited.
<b>ISFLT</b>	System fault active	
<b>IFLT</b>	Fault active	
<b>ITRB</b>	Trouble active	
<b>ITosp</b>	Quick stop by trouble active	
<b>WRN</b>	Warning is active	

#### Display parameters

The parameters listed in the following tables serve to query current states and actual values of the controller for diagnostic purposes, e.g. by using the keypad, a bus system or the »Engineer« (with an online connection to the controller).

- These parameters are listed in the »Engineer« parameter list and the keypad in the **Diagnostics** category.
- A detailed description of these parameters can be found in the chapter "[Parameter reference](#)".  
([□ 724](#))

Parameters	Display
<a href="#">C00183</a>	Device status
<a href="#">C00166</a>	Error description
<a href="#">C00168</a>	Error number
<a href="#">C00051</a>	Actual speed value [min-1]
<a href="#">C00052</a>	Motor voltage
<a href="#">C00054</a>	Motor current

Parameters	Display
<a href="#">C00057/1</a>	Maximum torque
<a href="#">C00057/2</a>	Motor reference torque
<a href="#">C00059</a>	Motor - number of pole pairs
<a href="#">C00060</a>	Motor pole angle
<a href="#">C00061</a>	Heatsink temperature
<a href="#">C00062</a>	Interior temperature
<a href="#">C00063</a>	Motor temperature
<a href="#">C00064</a>	Device utilisation (Ixt) during the last 180 seconds
<a href="#">C00065</a>	Ext. 24-V voltage
<a href="#">C00066</a>	Thermal motor load ( $I^2 \cdot t$ )
<a href="#">C00068</a>	Capacitor temperature
<a href="#">C00069</a>	CPU temperature
<a href="#">C00178</a>	Time the controller was enabled (elapsed-hour meter)
<a href="#">C00179</a>	Power-up time (power-on time meter)
<a href="#">C00186</a>	ENP: Identified motor type

#### Identification data

The parameters listed in the following table, which in the »Engineer« parameter list and in the keypad are classified in the category **Identification** → **Controller**, serve to display the identification data of the controller:

Parameters	Display
<a href="#">C00099</a>	Firmware version
<a href="#">C00200</a>	Firmware product type
<a href="#">C00201</a>	Firmware compilation date
<a href="#">C00203/1...9</a>	HW product types
<a href="#">C00204/1...9</a>	HW serial numbers
<a href="#">C00205/1...6</a>	HW descriptions
<a href="#">C00206/1...6</a>	HW manufacturing data
<a href="#">C00208/1...6</a>	HW manufacturer
<a href="#">C00209/1...6</a>	HW countries of origin
<a href="#">C00210/1...6</a>	HW versions
<a href="#">C02113</a>	Program name

## 13.4 Logbook

The integrated logbook function of the controller chronologically logs important events within the system and plays an important role for troubleshooting and controller diagnostics.

### Events that can be logged

The following events can be logged in the logbook:

- [Error messages of the operating system](#) (☞ 620)
- Error messages generated by the application
- Controller enable
- Starting / stopping the application
- Loading/saving of parameter sets, loading of the Lenze setting
- Transmitting an application or firmware to the controller
- Switching the controller on/off
- Formatting the file system



### Tip!

Use a parameterisable filter to exclude certain events from logbook entry. ▶ [Filtering logbook entries](#) (☞ 614)

### Information saved

For each event, the following information is saved in the logbook:

- Type of response to the event (e.g. fault, warning or information)
- Event
- Value of power-on time meter
- Date/time (for memory module with real-time clock)
- Module that activated the event (A = application; S = system).

### Memory depth

The number of possible logbook entries depends on the memory module used:

- MM1xx, MM2xx: 7 entries
- MM3xx, MM4xx: 439 entries

### 13.4.1 Functional description

The structure of the logbook corresponds to a ring buffer:

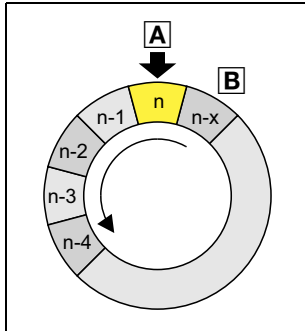

[13-3] Ring buffer structure

- As long as free logbook memory is available, the entry is placed in the next free position within the memory (A).
- If all memory units are assigned, the oldest entry (B) is deleted for a new entry.
- The newest entries will always remain available.

### 13.4.2 Filtering logbook entries

The logbook enters new entries in the ring buffer after they have passed through a parameterisable filter. By means of this filter you can exclude events with a specific error response (trouble, warning, information, etc.) from being entered in the logbook.



#### Note!

Events with the "No response" setting are not entered into the logbook.

The filter is parameterised in [C00169](#) by means of a bit mask. A set bit inhibits the entry of the corresponding event in the logbook.

- From software version V5.0 the option that identical consecutive entries ("Multiple entries") into the logbook are suppressed can be additionally activated via bit 0. Then only the time stamp of the last (latest) entry and the number of times the same event has occurred successively are saved.



Bit	Filter	Lenze setting
0	No multiple entries	0 ≙ filter inactive
1	Error	0 ≙ filter inactive
2	Fault	0 ≙ filter inactive
3	Quick stop by trouble	0 ≙ filter inactive
4	Warning locked	0 ≙ filter inactive
5	Warning	0 ≙ filter inactive
6	Information	0 ≙ filter inactive

### 13.4.3 Reading out logbook entries

With an online connection, the existing logbook entries can easily be displayed in the »Engineer«.



#### How to display logbook entries in the »Engineer«:

1. Go to the *Project view* and select the 9400 HighLine controller the logbook entries of which are to be read out.
2. Click the  icon or select the **Online→Go online** command to build up an online connection with the controller.
3. Select the **Diagnostics** tab from the *Workspace*.
4. Click the  symbol in the *diagnostics toolbar* to open the *Logbook* dialog box.

The *Logbook* dialog box displays all logbook entries available in the device. You can filter the entries displayed systematically by selecting or defining filter criteria.

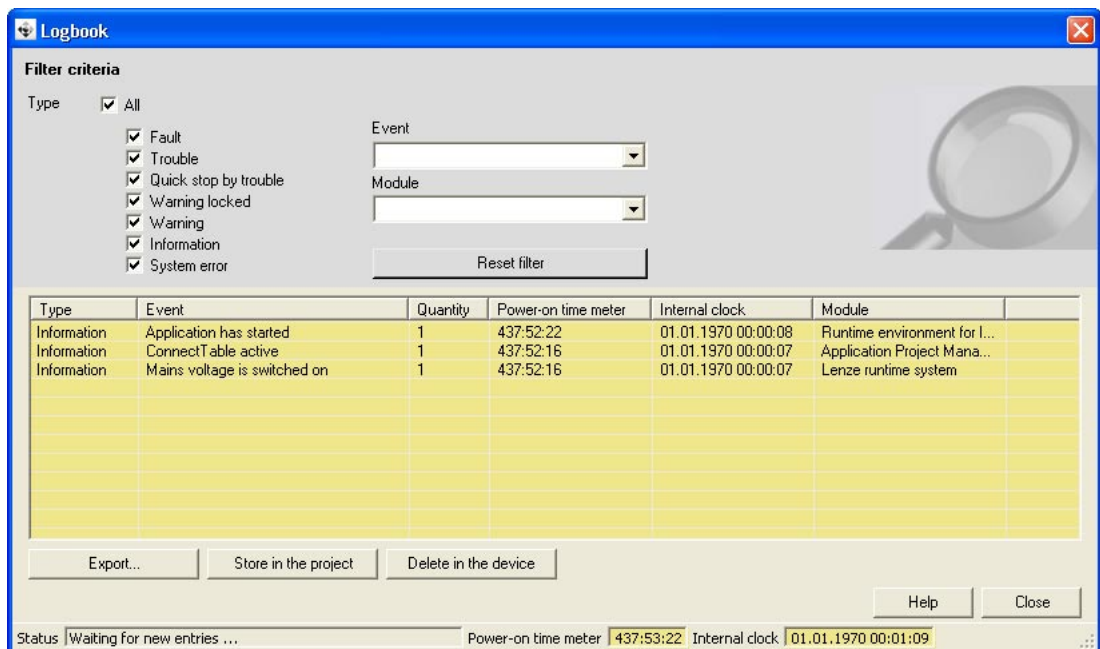

Button	Job title
Export...	<a href="#">Exporting logbook entries to a file (📄 616)</a>
Storing in the project	Storing logbook entries in the project. Logbook entries stored in the project are also displayed if there is no online connection to the controller (e.g. for service and documentation purposes).
Deleting in the device	Delete all logbook entries available in the device.

#### 13.4.4 Exporting logbook entries to a file



##### How to export the logbook entries to a file:

1. Click **Export...** in the *Logbook* dialog box.
  - The *Export logbook* dialog box is displayed.
2. Specify the folder, file name, and file type for the file.
3. Click the **Save** button to export the logbook entries into the given file.
  - Hidden logbook entries are not exported, i.e. the filter criteria specified are accounted for during the export.
  - The logbook entries are written to the file in the form of a semicolon separated list.

#### Example







```
Type;event;error number;number;power-on time meter;internal clock;module
Fault;motor:overtemperature;611778563;1;16243:36:56;01.01.1970 00:00;temperature monitoring
Fault;motor:thermal detector is defective;611778572;1;16243:36:56;01.01.1970 00:00;temperature
monitoring
Fault;resolver: open circuit;612040728;1;16243:36:55;01.01.1970 00:00;motor control
```



### 13.5 Monitoring

The controller is provided with various monitoring functions which protect the drive against impermissible operating conditions.

- If a monitoring function responds,
  - an entry will be made into the [Logbook](#) of the controller,
  - the response (quick stop by trouble, warning, fault, etc.) selected for this monitoring function is activated,
  - the status of the internal device control changes according to the selected response, controller inhibit is set, and the "DRIVE ERROR" LED on the front of the controller goes on:

Response	Logbook entry	Display in <a href="#">C00168</a>	Pulse inhibit	Inverter disable	Acknowledgement required	LED "DRIVE ERROR"
None						OFF
Information	<input checked="" type="checkbox"/>					OFF
Warning	<input checked="" type="checkbox"/>	<input checked="" type="checkbox"/>				
Warning locked	<input checked="" type="checkbox"/>	<input checked="" type="checkbox"/>			<input checked="" type="checkbox"/>	
Quick stop by trouble	<input checked="" type="checkbox"/>	<input checked="" type="checkbox"/>			<input checked="" type="checkbox"/>	
Fault	<input checked="" type="checkbox"/>	<input checked="" type="checkbox"/>	<input checked="" type="checkbox"/>	<input checked="" type="checkbox"/> (after 0.5 s)		
Error	<input checked="" type="checkbox"/>	<input checked="" type="checkbox"/>	<input checked="" type="checkbox"/>	<input checked="" type="checkbox"/>	<input checked="" type="checkbox"/>	
System fault	<input checked="" type="checkbox"/>	<input checked="" type="checkbox"/>	<input checked="" type="checkbox"/>	<input checked="" type="checkbox"/>	Mains switching is required!	



#### Danger!

If automatic restart is enabled ([C00142](#) = "1: Enabled"), the drive can restart automatically from the "Trouble" and "Safe torque off" device states when the trouble or request for "Safe torque off active" has been eliminated!

▶ [Automatic restart after mains connection/trouble...](#) (📖 107)

See also:

- ▶ [Device states](#) (📖 100)
- ▶ [LED status displays for the device state](#) (📖 609)

### 13.5.1 Setting the error response

If a monitoring function responds, the response set for this monitoring function (quick stop by trouble, warning, fault, etc.) is triggered.

- For many monitoring functions the response can be individually parameterised via parameters.

	C	S	Name	Value	Unit
	580	0	Resp. to encoder open circuit	Error	
	581	0	Resp. to external fault	1: Error	
	582	0	Resp. to heatsink temp. > C00122	0: No response	
	583	0	Resp. to motor overtemp. KTY	1: Error	
	584	0	Resp. to motor temp. > C00121	2: Fault	
	585	0	Resp. to motor overtemp. PTC	3: Quick stop by trouble	
	586	0	Resp. to resolver open circuit	4: Warning locked	
	586	0	Resp. to resolver open circuit	5: Warning	
	587	0	Status - fan control	6: Info	
				0x00	



#### Tip!

The table in the chapter "[Short overview \(A-Z\)](#)" contains the error messages for which the response can be set. (626)

### Warning thresholds

Some of the monitoring functions are activated if a defined warning threshold (e.g. temperature) has been exceeded.

- The corresponding preset threshold values can be changed via the following parameters:

Parameters	Info
<a href="#">C00120</a>	Motor overload protection (I <sup>2</sup> t)
<a href="#">C00121</a>	Motor temp. warning threshold
<a href="#">C00122</a>	Heatsink temp. warn. threshold
<a href="#">C00123</a>	Device utilisation warning threshold
<a href="#">C00126</a>	CPU temp. warning threshold
<a href="#">C00127</a>	Mot. overload warning threshold
<a href="#">C00128</a>	Thermal time constant of motor
<a href="#">C00174</a>	Undervoltage (LU) threshold
<a href="#">C00570</a>	Warning thres. brake transistor
<a href="#">C00572</a>	Warning thres. brake resistor
<a href="#">C00576</a>	Speed monitoring tolerance
<a href="#">C00596</a>	Threshold max. speed reached
<a href="#">C00599</a>	Motor phase failure threshold
<a href="#">C00620</a>	Max. motor current threshold

## 13.6 Maloperation of the drive

The motor does not rotate.

Cause	Remedy
DC-bus voltage is too low.	Check mains voltage.
Controller is inhibited.	Deactivate controller inhibit (can be set by several sources).
Motor holding brake is not released.	Release motor holding brake.
Quick stop is active	Deactivate quick stop
Setpoint = 0	Select setpoint.

With a positive speed setpoint selection, the motor rotates counter-clockwise instead of clockwise (when looking at the motor shaft).

Cause	Remedy
Feedback system is not connected in correct phase relation.	Connect feedback system in correct phase relation.

The maximum current (C00022) flows and the motor does not rotate according to the defined speed setpoint.

Cause	Remedy
Two motor phases are interchanged, i.e. an anti-clockwise rotating field is applied to the motor.	<p>Carry out the following steps for verification:</p> <ol style="list-style-type: none"> <li>1. Ensure that the motor shaft is not blocked and can rotate freely without damaging the system.</li> <li>2. Activate the "U-rotation test mode" for the motor control (C00398 = "1"). <ul style="list-style-type: none"> <li>• In this test mode a voltage phasor with the frequency set in C00399/1 and the amplitude from the linear characteristic of rated voltage and rated frequency is applied to the machine, which corresponds to a clockwise rotating field.</li> <li>• <b>⚠ Danger!</b> <b>When the test mode is active, the parameterisable error response "Quick stop by trouble" has no effect!</b> If the test mode is active and a monitoring function responds with this error response, <u>no</u> quick stop is executed but the motor continues to rotate with the frequency set for the test mode!</li> </ul> </li> <li>3. Increase the frequency step by step for the test mode in C00399/1 until the motor shaft starts to rotate. <ul style="list-style-type: none"> <li>• If the motor shaft does not rotate, check the electrical connection.</li> </ul> </li> <li>4. While the motor shaft is rotating, check whether it rotates clockwise when looking at the A end shield. If not, two motor phases are interchanged.</li> <li>5. Additionally check whether the actual speed value shown in C00051 is positive and whether it corresponds to the defined frequency, taking the number of pole pairs of the machine into consideration (C00059). If this is not the case, the connection and the parameter setting of the feedback system are to be checked.</li> <li>6. Deactivate the test mode for the motor control again (C00398 = "0").</li> </ol>

# 13 Diagnostics & fault analysis

## 13.7 Error messages of the operating system

### 13.7 Error messages of the operating system

This chapter describes all error messages of the controller operating system and possible causes & remedies.



**Tip!**

Each error message is also saved to the logbook in chronological order. ▶ [Logbook](#) (📖 613)

#### 13.7.1 Structure of the error number (bit coding)

If an error occurs in the controller, a 32-bit value will be saved in decimal format in the internal history buffer ([C00168](#)), which contains the following information:

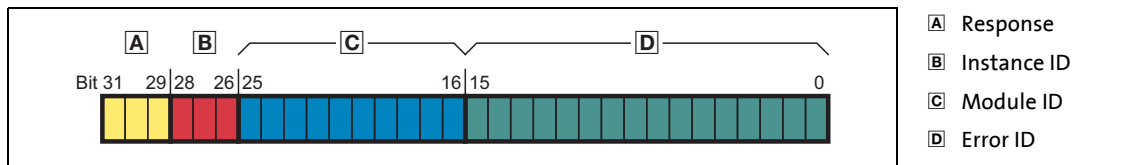

[13-4] Structure of the error number



**Tip!**

If you go to the **Diagnostics** tab and click the button  to the right of the **Error description** display parameter, you will be shown all details on the current error in a separate dialog box.

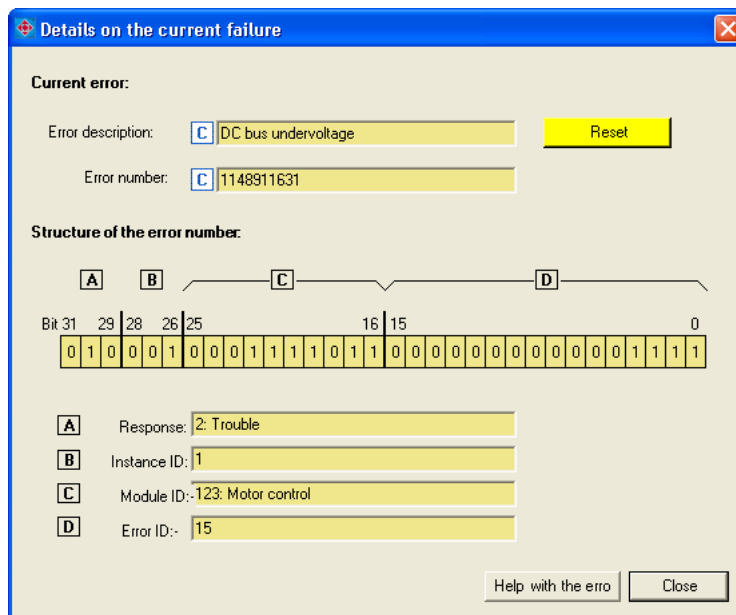

### 13.7.1.1 Response



Bit 31	Bit 30	Bit 29	Response
0	0	0	0: No Response
0	0	1	1: Error
0	1	0	2: Trouble
0	1	1	3: Quick stop by trouble
1	0	0	4: Warning locked
1	0	1	5: Warning
1	1	0	6: Information
1	1	1	7: System fault

The state of the internal device control changes according to the selected response to an error, controller inhibit is set, and the "DRIVE ERROR" LED on the front of the controller goes on:

Response	Logbook entry	Display in <a href="#">C00168</a>	Pulse inhibit	Inverter disable	Acknowledgement required	LED "DRIVE ERROR"
None						OFF
Information	<input checked="" type="checkbox"/>					OFF
Warning	<input checked="" type="checkbox"/>	<input checked="" type="checkbox"/>				
Warning locked	<input checked="" type="checkbox"/>	<input checked="" type="checkbox"/>			<input checked="" type="checkbox"/>	
Quick stop by trouble	<input checked="" type="checkbox"/>	<input checked="" type="checkbox"/>			<input checked="" type="checkbox"/>	
Fault	<input checked="" type="checkbox"/>	<input checked="" type="checkbox"/>	<input checked="" type="checkbox"/>	<input checked="" type="checkbox"/> (after 0.5 s)		
Error	<input checked="" type="checkbox"/>	<input checked="" type="checkbox"/>	<input checked="" type="checkbox"/>	<input checked="" type="checkbox"/>	<input checked="" type="checkbox"/>	
System fault	<input checked="" type="checkbox"/>	<input checked="" type="checkbox"/>	<input checked="" type="checkbox"/>	<input checked="" type="checkbox"/>	Mains switching is required!	

### 13.7.1.2 Instance ID



The instance ID is dynamically assigned by the operating system.

Bit 28	Bit 27	Bit 26	Meaning
0	0	0	Instance ID 0
0	0	1	Instance ID 1
0	1	0	Instance ID 2
0	1	1	Instance ID 3
1	0	0	Instance ID 4
1	0	1	Instance ID 5
1	1	0	Instance ID 6
1	1	1	Instance ID 7

### 13.7.1.3 Module ID

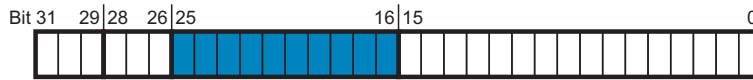

Use the module ID to identify the module in which the error has occurred.

Module ID		Module
hex	decimal	
0x0065	101	Logbook module
0x0068	104	Module recognition
0x0069	105	Error check of the program memory for runtime
0x006a	106	Runtime environment for IEC 61131-3 programs
0x006e	110	Supply voltage monitoring
0x006f	111	24-V supply voltage monitoring
0x0072	114	Service register
0x0075	117	Drive control
0x0077	119	Temperature monitoring
0x0078	120	Analog signal monitoring
0x0079	121	Motor data interface
0x007a	122	Processing the digital inputs/outputs
0x007b	123	Motor control
0x007c	124	Device command module ( <a href="#">C00002</a> )
0x007d	125	Processing the analog inputs/outputs
0x007f	127	Interface to the intelligent communication module
0x0083	131	"CAN on board": CAN-Dispatcher
0x0084	132	"CAN on board": CAN-NMT-Handler
0x0085	133	"CAN on board": CAN-Emergency-Handler
0x0086	134	"CAN on board": CAN-NMT-Master
0x0087	135	"CAN on board": CAN-PDO-Handler
0x0088	136	"CAN on board": CAN-SDO-Server
0x0089	137	"CAN on board": CAN-SDO-Client
0x008c	140	Application project manager
0x008e	142	Communication interface for internal communication
0x0090	144	Parameter manager
0x0091	145	Lenze runtime system
0x0092	146	Interface to the safety module
0x0093	147	Sync signal generation
0x0099	153	Extension module - digital frequency in MXI1
0x009d	157	CAN module in MXI1: CAN-Dispatcher
0x009e	158	CAN module in MXI1: CAN-NMT-Handler
0x009f	159	CAN module in MXI1: CAN-Emergency-Handler
0x00a0	160	CAN module in MXI1: CAN-NMT-Master
0x00a1	161	CAN module in MXI1: CAN-PDO-Handler
0x00a2	162	CAN module in MXI1: CAN-SDO-Server
0x00a3	163	CAN module in MXI1: CAN-SDO-Client
0x00aa	170	Extension module - digital frequency in MXI2

Module ID		Module
hex	decimal	
0x00ac	172	CAN module in MXI2: CAN-Dispatcher
0x00ad	173	CAN module in MXI2: CAN-NMT-Handler
0x00ae	174	CAN module in MXI2: CAN-Emergency-Handler
0x00af	175	CAN module in MXI2: CAN-NMT-Master
0x00b0	176	CAN module in MXI2: CAN-PDO-Handler
0x00b1	177	CAN module in MXI2: CAN-SDO-Server
0x00b2	178	CAN module in MXI2: CAN-SDO-Client
0x00b8	184	Basic drive functions
0x00c8	200	Intelligent communication module
0x012f	303	Safety module SM300/SM301
0x3ac	940	Servodrive function library
0x3ad	941	Linedrive function library
0x3ae	942	Positioning function library
0x3af	943	Cam function library
0x3b0	944	Toolbox function library
0x3b1	945	Device9400 function library
0x3b2	946	Dataconversion function library
0x3b3	947	Electricalshaft function library
0x3b4	948	CIA402 function library

13.7.1.4 Error ID

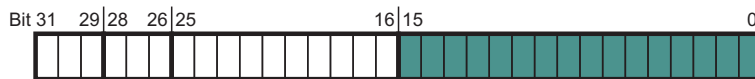

16-bit value (0 ... 65535<sub>dec</sub>) for error identification.

13.7.1.5 Example for bit coding of the error number

C00168 displays the error number "1148911631".

- This decimal value corresponds to the following bit sequence:

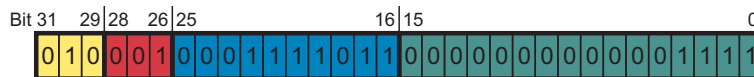

Assignment	Information	Meaning in the example
010	<a href="#">Response</a>	2: Trouble
001	<a href="#">Instance ID</a>	1: Instance ID 1
0001111011	<a href="#">Module ID</a>	Module ID 123 (0x007b): Motor control
0000000000001111	<a href="#">Error ID</a>	Error ID 15 (0x000f) for motor control: <a href="#">Undervoltage in the DC bus</a>

- Error number "1148911631" thus means:  
The "DC-bus undervoltage" error with the response "Trouble" occurred in the "motor control" module with the instance ID 1.



### 13.7.2 Reset error message

An error message with the response "Fault", "Quick stop by trouble", or "Warning locked" must be reset (acknowledged) explicitly after the cause of error has been eliminated.



To reset (acknowledge) a pending error message, execute the device command [C00002](#) = "43: Reset error".



**Tip!**

When an online connection to the controller has been established, use the **Diagnostics** tab of »Engineer« and click **Reset error** to reset a pending error message.

### 13.7.3 Short overview (A-Z)

The following table contains all error messages of the controller operating system in alphabetical order with the preset error response and - if available – the parameter for setting the error response.



#### Tip!

If you click on the cross-reference in the first column, you get to the detailed description of the corresponding error response in the following chapter "[Cause & possible remedies](#)".  
([634](#))



#### Note!

##### Error message "Unknown error"

If the "Unknown error xxxx" error message is indicated in the logbook or in [C00166](#), the reason for the missing plain text is that the error texts required have not been downloaded to the controller during the application download.

- This, for instance, is the case if a device module plugged into the controller has not been included in the Engineer project.
- Remedy: Include the device module, recompile and download the project.

hex	dec	Error message	Response (Lenze setting)	Adjustable in
<a href="#">0x0090000c</a>	9437196	Disconnection in the case of par. storage	Error	-
<a href="#">0x007b001a</a>	8060954	Absolute value encoder: Communication error	Error	-
<a href="#">0x006a0000</a>	6946816	General error in the application	Error	-
<a href="#">0x007d0000</a>	8192000	Analog input 1: master current < 4 mA	Error	<a href="#">C00598</a>
<a href="#">0x00750001</a>	7667713	Controller is enabled	Information	-
<a href="#">0x00750003</a>	7667715	Controller in STO state	Information	-
<a href="#">0x007b0047</a>	8060999	Controller: Clamp operation	Information	-
<a href="#">0x00750005</a>	7667717	Controller: Pulse inhibit is active	Information	-
<a href="#">0x007b0035</a>	8060981	Controller: Overload during acceleration phases	Error	-
<a href="#">0x006a0004</a>	6946820	ApplicationTask: Overflow	Error	<a href="#">C02111</a>
<a href="#">0x006a0013</a>	6946835	Application has started	Information	-
<a href="#">0x006a000e</a>	6946830	Application has stopped	Information	-
<a href="#">0x006a0014</a>	6946836	Application has stopped	Information	-
<a href="#">0x008c000c</a>	9175052	Application and device are incompatible	Error	-
<a href="#">0x006a0010</a>	6946832	Faulty application parameter	Error	-
<a href="#">0x007b003f</a>	8060991	A mains phase has failed	Error	-
<a href="#">0x007b002d</a>	8060973	Failure of motor phase U	No response	<a href="#">C00597</a>
<a href="#">0x007b002e</a>	8060974	Failure of motor phase V	No response	<a href="#">C00597</a>
<a href="#">0x007b002f</a>	8060975	Failure of motor phase W	No response	<a href="#">C00597</a>
<a href="#">0x00b8000c</a>	12058636	Acceleration has been limited	Information	<a href="#">C02716/3</a>
<a href="#">0x00910012</a>	9502738	Block function in wrong MEC task	Error	-
<a href="#">0x006a000f</a>	6946831	Breakpoint reached	Information	-
<a href="#">0x007b0040</a>	8060992	Brake chopper: Ixt > C00570	Warning	<a href="#">C00569</a>
<a href="#">0x007b001c</a>	8060956	Brake transistor: Ixt overload	No response	<a href="#">C00573</a>
<a href="#">0x007b0021</a>	8060961	Brake transistor: Overcurrent	Error	-
<a href="#">0x007b0041</a>	8060993	Brake resistor: I2t > C00572	Warning	<a href="#">C00571</a>
<a href="#">0x007b001d</a>	8060957	Brake resistor: I³xt overload	Information	-
<a href="#">0x00b80014</a>	12058644	Cam Data is corrupted	Warning locked	-
<a href="#">0x00b80016</a>	12058646	Cam Data locked due to wrong password	Warning locked	-

hex	dec	Error message	Response (Lenze setting)	Adjustable in
<a href="#">0x00b80017</a>	12058647	Cam Data locked due to wrong security key	Warning locked	-
<a href="#">0x00b80015</a>	12058645	Cam Data restored	Error	-
<a href="#">0x00b80013</a>	12058643	Cam data: serial number MM does not match	Warning locked	-
<a href="#">0x00b80034</a>	12058676	Cam Data: Invalidated (due to change of mechanical data)	Warning	-
<a href="#">0x00b80035</a>	12058677	Cam Data: Invalid product number	Information	-
<a href="#">0x00870008</a>	8847368	CAN on board PDO manager: faulty configuration	Warning locked	-
<a href="#">0x00870000</a>	8847360	CAN on board RPDO1: Telegram not received or faulty	No response	<a href="#">C00591/1</a>
<a href="#">0x00870001</a>	8847361	CAN on board RPDO2: Telegram not received or faulty	No response	<a href="#">C00591/2</a>
<a href="#">0x00870002</a>	8847362	CAN on board RPDO3: Telegram not received or faulty	No response	<a href="#">C00591/3</a>
<a href="#">0x00870003</a>	8847363	CAN on board RPDO4: Telegram not received or faulty	No response	<a href="#">C00591/4</a>
<a href="#">0x00890000</a>	8978432	CAN on board SDO client: Faulty configuration	Warning locked	-
<a href="#">0x00880000</a>	8912896	CAN on board SDO server: Faulty configuration	Warning locked	-
<a href="#">0x00830002</a>	8585218	CAN on board: Basic configuration invalid	Warning locked	-
<a href="#">0x00830000</a>	8585216	CAN on board: Bus off	No response	<a href="#">C00595</a>
<a href="#">0x00850000</a>	8716288	CAN on board: Faulty emergency configuration	Warning locked	-
<a href="#">0x00840000</a>	8650752	CAN on board: Heartbeat error index 1 ... 32	No response	<a href="#">C00613/1...32</a>
<a href="#">0x00840020</a>	8650784	CAN on board: Lifeguarding error	No response	<a href="#">C00614</a>
<a href="#">0x00860020</a>	8781856	CAN on board: Faulty NMT master configuration	Warning locked	-
<a href="#">0x00840021</a>	8650785	CAN on board: Faulty NMT slave configuration	Warning locked	-
<a href="#">0x00860000</a>	8781824	CAN on board: Node guarding error 1 ... 32	No response	<a href="#">C00612/1...32</a>
<a href="#">0x00830001</a>	8585217	CAN on board: Invalid node address 0	Warning	-
<a href="#">0x00a10008</a>	10551304	CAN module (MXI1) PDO manager: Faulty configuration	Warning locked	-
<a href="#">0x00a10000</a>	10551296	CAN module (MXI1) RPDO1: Telegram not received or faulty	No response	<a href="#">C13591/1</a>
<a href="#">0x00a10001</a>	10551297	CAN module (MXI1) RPDO2: Telegram not received or faulty	No response	<a href="#">C13591/2</a>
<a href="#">0x00a10002</a>	10551298	CAN module (MXI1) RPDO3: Telegram not received or faulty	No response	<a href="#">C13591/3</a>
<a href="#">0x00a10003</a>	10551299	CAN module (MXI1) RPDO4: Telegram not received or faulty	No response	<a href="#">C13591/4</a>
<a href="#">0x00a10004</a>	10551300	CAN module (MXI1) RPDO5: Telegram not received or faulty	No response	<a href="#">C13591/5</a>
<a href="#">0x00a10005</a>	10551301	CAN module (MXI1) RPDO6: Telegram not received or faulty	No response	<a href="#">C13591/6</a>
<a href="#">0x00a10006</a>	10551302	CAN module (MXI1) RPDO7: Telegram not received or faulty	No response	<a href="#">C13591/7</a>
<a href="#">0x00a10007</a>	10551303	CAN module (MXI1) RPDO8: Telegram not received or faulty	No response	<a href="#">C13591/8</a>
<a href="#">0x00a30000</a>	10682368	CAN module (MXI1) SDO client: faulty configuration	Warning locked	-
<a href="#">0x00a20000</a>	10616832	CAN module (MXI1) SDO server: faulty configuration	Warning locked	-
<a href="#">0x009d0000</a>	10289152	CAN module (MXI1): Bus off	Information	<a href="#">C13595</a>
<a href="#">0x009f0000</a>	10420224	Can module (MXI1): Faulty emergency configuration	Warning locked	-
<a href="#">0x009e0021</a>	10354721	CAN module (MXI1): Faulty NMT slave configuration	Warning locked	-
<a href="#">0x009d0002</a>	10289154	CAN module (MXI1): Basic configuration invalid	Warning locked	-
<a href="#">0x009e0000</a>	10354688	CAN module (MXI1): Heartbeat error index 1 ... 32	No response	<a href="#">C13613/1...32</a>
<a href="#">0x009e0020</a>	10354720	CAN module (MXI1): Lifeguarding error	No response	<a href="#">C13614</a>
<a href="#">0x00a00020</a>	10485792	CAN module (MXI1): Faulty NMT master configuration	Warning locked	-
<a href="#">0x00a00000</a>	10485760	CAN module (MXI1): node guarding error 1 ... 32	No response	<a href="#">C13612/1...32</a>
<a href="#">0x009d0001</a>	10289153	CAN module (MXI1): Invalid node address 0	Warning	-
<a href="#">0x00b00008</a>	11534344	CAN module (MXI2) PDO manager: Faulty configuration	Warning locked	-
<a href="#">0x00b00000</a>	11534336	CAN module (MXI2) RPDO1: Telegram not received or faulty	No response	<a href="#">C14591/1</a>
<a href="#">0x00b00001</a>	11534337	CAN module (MXI2) RPDO2: Telegram not received or faulty	No response	<a href="#">C14591/2</a>
<a href="#">0x00b00002</a>	11534338	CAN module (MXI2) RPDO3: Telegram not received or faulty	No response	<a href="#">C14591/3</a>
<a href="#">0x00b00003</a>	11534339	CAN module (MXI2) RPDO4: Telegram not received or faulty	No response	<a href="#">C14591/4</a>
<a href="#">0x00b00004</a>	11534340	CAN module (MXI2) RPDO5: Telegram not received or faulty	No response	<a href="#">C14591/5</a>
<a href="#">0x00b00005</a>	11534341	CAN module (MXI2) RPDO6: Telegram not received or faulty	No response	<a href="#">C14591/6</a>
<a href="#">0x00b00006</a>	11534342	CAN module (MXI2) RPDO7: Telegram not received or faulty	No response	<a href="#">C14591/7</a>
<a href="#">0x00b00007</a>	11534343	CAN module (MXI2) RPDO8: Telegram not received or faulty	No response	<a href="#">C14591/8</a>
<a href="#">0x00b20000</a>	11665408	CAN module (MXI2) SDO client: faulty configuration	Warning locked	-
<a href="#">0x00b10000</a>	11599872	CAN module (MXI2) SDO server: faulty configuration	Warning locked	-

hex	dec	Error message	Response (Lenze setting)	Adjustable in
<a href="#">0x00ac0000</a>	11272192	CAN module (MXI2): Bus off	Information	<a href="#">C14595</a>
<a href="#">0x00ae0000</a>	11403264	Can module (MXI2): Faulty emergency configuration	Warning locked	-
<a href="#">0x00ac0002</a>	11272194	CAN module (MXI2): Basic configuration invalid	Warning locked	-
<a href="#">0x00ad0000</a>	11337728	CAN module (MXI2): Heartbeat error index 1 ... 32	No response	<a href="#">C14613/1...32</a>
<a href="#">0x00ad0020</a>	11337760	CAN module (MXI2): Lifeguarding error	No response	<a href="#">C14614</a>
<a href="#">0x00af0020</a>	11468832	CAN module (MXI2): NMT master configuration incomplete	Warning locked	-
<a href="#">0x00ad0021</a>	11337761	CAN module (MXI2): NMT slave configuration incomplete	Warning locked	-
<a href="#">0x00af0000</a>	11468800	CAN module (MXI2): Node guarding error 1 ... 32	No response	<a href="#">C14612/1...32</a>
<a href="#">0x00ac0001</a>	11272193	CAN module (MXI2): Invalid node address 0	Warning	-
<a href="#">0x00900008</a>	9437192	Code number duplicated	Warning locked	-
<a href="#">0x00690000</a>	6881280	Code refresh	System fault	-
<a href="#">0x008c001a</a>	9175066	ConnectTable active	Information	-
<a href="#">0x00770008</a>	7798792	CPU: Temperature > C00126	No response	<a href="#">C00589</a>
<a href="#">0x0077000e</a>	7798798	CPU: thermal detector is defective	Error	<a href="#">C00588</a>
<a href="#">0x00770009</a>	7798793	CPU: Overtemperature	Warning	-
<a href="#">0x008c0002</a>	9175042	File DeviceCFG.dat is defective	Error	-
<a href="#">0x008c0005</a>	9175045	File DeviceCFG.dat is missing	Error	-
<a href="#">0x008c0008</a>	9175048	File DeviceCFG.dat is invalid	Error	-
<a href="#">0x008c0001</a>	9175041	File ProjectList.dat is defective	Error	-
<a href="#">0x008c0004</a>	9175044	File ProjectList.dat is missing	Error	-
<a href="#">0x008c0007</a>	9175047	File ProjectList.dat is invalid	Error	-
<a href="#">0x008c0000</a>	9175040	File ProjectSelection.dat is defective	Error	-
<a href="#">0x008c0003</a>	9175043	File ProjectSelection.dat is missing	Error	-
<a href="#">0x008c0006</a>	9175046	File ProjectSelection.dat is invalid	Error	-
<a href="#">0x00990003</a>	10027011	DFIN (MXI1): Signal error enable/lamp control	Warning	<a href="#">C13041</a>
<a href="#">0x00990000</a>	10027008	DFIN (MXI1): Track error A-/A	Error	<a href="#">C13040</a>
<a href="#">0x00990001</a>	10027009	DFIN (MXI1): Track error B-/B	Error	<a href="#">C13040</a>
<a href="#">0x00990002</a>	10027010	DFIN (MXI1): Track error Z-/Z	Error	<a href="#">C13040</a>
<a href="#">0x00990004</a>	10027012	DFIN (MXI1): Supply cannot be corrected anymore	Warning	<a href="#">C13042</a>
<a href="#">0x00aa0003</a>	11141123	DFIN (MXI2): Signal error enable/lamp control	Warning	<a href="#">C14041</a>
<a href="#">0x00aa0000</a>	11141120	DFIN (MXI2): Track error A-/A	Error	<a href="#">C14040</a>
<a href="#">0x00aa0001</a>	11141121	DFIN (MXI2): Track error B-/B	Error	<a href="#">C14040</a>
<a href="#">0x00aa0002</a>	11141122	DFIN (MXI2): Track error Z-/Z	Error	<a href="#">C14040</a>
<a href="#">0x00aa0004</a>	11141124	DFIN (MXI2): Supply cannot be corrected anymore	Warning	<a href="#">C14042</a>
<a href="#">0x00990005</a>	10027013	DFOUT (MXI1): Maximum frequency reached	Warning	<a href="#">C13080</a>
<a href="#">0x00aa0005</a>	11141125	DFOUT (MXI2): Maximum frequency reached	Warning	<a href="#">C14080</a>
<a href="#">0x006a0011</a>	6946833	Division by zero	Error	-
<a href="#">0x006a0001</a>	6946817	Faulty program download	Error	-
<a href="#">0x007b0012</a>	8060946	Actual speed value outside tolerance (C00576)	No response	<a href="#">C00579</a>
<a href="#">0x00680022</a>	6815778	Real-time clock is defective	Warning locked	-
<a href="#">0x00680024</a>	6815780	Real-time clock: No battery, time lost	Warning locked	-
<a href="#">0x00680023</a>	6815779	Real-time clock: Change battery	Warning locked	-
<a href="#">0x007b0039</a>	8060985	Electronic nameplate: Data outside parameter limits	Information	-
<a href="#">0x007b0030</a>	8060976	Electronic nameplate: Data loaded	Information	-
<a href="#">0x0078000a</a>	7864330	Electronic nameplate: Data are incompatible	Information	-
<a href="#">0x007b0032</a>	8060978	Electronic nameplate: Encoder protocol unknown	Information	-
<a href="#">0x007b0033</a>	8060979	Electronic nameplate: Encoder signal unknown	Information	-
<a href="#">0x0068001b</a>	6815771	Electronic nameplate: Communication error	Warning	-
<a href="#">0x007b0031</a>	8060977	Electronic nameplate: Not found	Information	-
<a href="#">0x0068001d</a>	6815773	Electronic nameplate: Checksum error	Warning	-
<a href="#">0x007b001b</a>	8060955	Encoder: Open circuit	Error	<a href="#">C00580</a>
<a href="#">0x007b002c</a>	8060972	EnDat encoder: Battery empty	Information	-

hex	dec	Error message	Response (Lenze setting)	Adjustable in
<a href="#">0x007b004f</a>	8061007	EnDat encoder: Command error	Information	-
<a href="#">0x007b0026</a>	8060966	EnDat encoder: Lamp error	Information	-
<a href="#">0x007b0050</a>	8061008	EnDat encoder: Initial position error	Information	-
<a href="#">0x007b0028</a>	8060968	EnDat encoder: Position error	Information	-
<a href="#">0x007b0027</a>	8060967	EnDat encoder: Signal error	Information	-
<a href="#">0x007b0029</a>	8060969	EnDat encoder: Overvoltage	Information	-
<a href="#">0x007b002b</a>	8060971	EnDat encoder: Overcurrent	Information	-
<a href="#">0x007b004e</a>	8061006	EnDat encoder: Transmission error	Information	-
<a href="#">0x007b002a</a>	8060970	EnDat encoder: Undervoltage	Information	-
<a href="#">0x007b0011</a>	8060945	Earth fault detected	Error	-
<a href="#">0x008c000b</a>	9175051	Required license missing	Error	-
<a href="#">0x00750000</a>	7667712	External error	Error	<a href="#">C00581</a>
<a href="#">0x00680013</a>	6815763	Incorrect safety module	System fault	-
<a href="#">0x00680012</a>	6815762	Incorrect memory module	System fault	-
<a href="#">0x006a0002</a>	6946818	Error during the update of inputs and outputs	Error	-
<a href="#">0x006a0017</a>	6946839	Error in control configuration	System fault	-
<a href="#">0x00910011</a>	9502737	Error during initialisation	System fault	-
<a href="#">0x0068001e</a>	6815774	Firmware incompatible to control card	System fault	-
<a href="#">0x0068001a</a>	6815770	Firmware has been changed	Information	-
<a href="#">0x007b003e</a>	8060990	Encoder monitoring: Pulse deviation detected	No response	<a href="#">C00621</a>
<a href="#">0x00780001</a>	7864321	Device utilisation lxt > 100 %	Error	-
<a href="#">0x00780000</a>	7864320	Device utilisation lxt > C00123	Warning	<a href="#">C00604</a>
<a href="#">0x00790000</a>	7929856	Incorrect device command transfer	System fault	-
<a href="#">0x00770011</a>	7798801	Inside the device: fan is defective	Error	<a href="#">C00611</a>
<a href="#">0x0077000b</a>	7798795	Inside the device: thermal detector is defective	Error	<a href="#">C00588</a>
<a href="#">0x00b8000b</a>	12058635	Speed has been limited	Information	<a href="#">C02716/3</a>
<a href="#">0x00910003</a>	9502723	Heartbeat not periodic	System fault	-
<a href="#">0x007b003b</a>	8060987	Hiperface encoder: Command error	Information	-
<a href="#">0x007b003c</a>	8060988	Hiperface encoder: Unknown encoder	Information	-
<a href="#">0x007b003d</a>	8060989	Hiperface encoder: Initial position error	Information	-
<a href="#">0x007b003a</a>	8060986	Hiperface encoder: Transmission error	Information	-
<a href="#">0x006a0006</a>	6946822	IdleTask: Overflow	Error	-
<a href="#">0x00b8001a</a>	12058650	Int. overflow C02620 (manual jog: speed 1)	Error	-
<a href="#">0x00b8001b</a>	12058651	Int. overflow C02621 (manual jog: speed 2)	Error	-
<a href="#">0x00b8001c</a>	12058652	Int. overflow C02622 (manual jog: acc.)	Error	-
<a href="#">0x00b8001d</a>	12058653	Int. overflow C02623 (manual jog: dec.)	Error	-
<a href="#">0x00b8002d</a>	12058669	Int. overflow C02642 (home position)	Error	-
<a href="#">0x00b8002e</a>	12058670	Int. overflow C02643 (homing: target position)	Error	-
<a href="#">0x00b8002f</a>	12058671	Int. overflow C02644 (homing: speed 1)	Error	-
<a href="#">0x00b80030</a>	12058672	Int. overflow C02645 (homing: acceleration 1)	Error	-
<a href="#">0x00b80031</a>	12058673	Int. overflow C02646 (homing: speed 2)	Error	-
<a href="#">0x00b80032</a>	12058674	Int. overflow C02647 (homing: acceleration 2)	Error	-
<a href="#">0x00b80033</a>	12058675	Int. overflow C02670 (positioner: tol. for target position)	Error	-
<a href="#">0x00b80020</a>	12058656	Int. overflow C02701/1 (positive software limit pos.)	Error	-
<a href="#">0x00b80021</a>	12058657	Int. overflow C02701/2 (negative software limit pos.)	Error	-
<a href="#">0x00b80022</a>	12058658	Int. overflow C02703 (maximum speed)	Error	-
<a href="#">0x00b80023</a>	12058659	Int. overflow C02705 (maximum acceleration)	Error	-
<a href="#">0x00b80028</a>	12058664	Int. overflow C02708/1 (decel. limited speed 1)	Error	-
<a href="#">0x00b80024</a>	12058660	Int. overflow C02708/1 (limited speed 1)	Error	-
<a href="#">0x00b80029</a>	12058665	Int. overflow C02708/2 (decel. limited speed 2)	Error	-
<a href="#">0x00b80025</a>	12058661	Int. overflow C02708/2 (limited speed 2)	Error	-
<a href="#">0x00b8002a</a>	12058666	Int. overflow C02708/3 (decel. limited speed 3)	Error	-

hex	dec	Error message	Response (Lenze setting)	Adjustable in
<a href="#">0x00b80026</a>	12058662	Int. overflow C02708/3 (limited speed 3)	Error	-
<a href="#">0x00b8002b</a>	12058667	Int. overflow C02708/4 (decel. limited speed 4)	Error	-
<a href="#">0x00b80027</a>	12058663	Int. overflow C02708/4 (limited speed 4)	Error	-
<a href="#">0x00b8002c</a>	12058668	Int. overflow C02713 (max. dist. manual control)	Error	-
<a href="#">0x008c001d</a>	9175069	Internal error (CRC application)	Error	-
<a href="#">0x00690009</a>	6881289	Internal error (event mechanism)	System fault	-
<a href="#">0x0069000a</a>	6881290	Internal error (event mechanism)	System fault	-
<a href="#">0x00690002</a>	6881282	Internal error (LDS instance data)	System fault	-
<a href="#">0x00690003</a>	6881283	Internal error (LDS tasks)	System fault	-
<a href="#">0x0069000d</a>	6881293	Internal error (file system lifetime)	Warning	-
<a href="#">0x00690007</a>	6881287	Internal error (message queue)	System fault	-
<a href="#">0x00690006</a>	6881286	Internal error (message memory)	System fault	-
<a href="#">0x00690008</a>	6881288	Internal error (name database)	System fault	-
<a href="#">0x0069000b</a>	6881291	Internal error (semaphores)	System fault	-
<a href="#">0x0069000c</a>	6881292	Internal error (semaphores)	System fault	-
<a href="#">0x00690001</a>	6881281	Internal error (memory area - logbook)	System fault	-
<a href="#">0x00690004</a>	6881284	Internal error (memory blocks)	System fault	-
<a href="#">0x00690005</a>	6881285	Internal error (task queue)	System fault	-
<a href="#">0x00910004</a>	9502724	Internal error: See C00180	System fault	-
<a href="#">0x00910005</a>	9502725	Internal error: See C00180	System fault	-
<a href="#">0x00910006</a>	9502726	Internal error: See C00180	System fault	-
<a href="#">0x00910008</a>	9502728	Internal error: See C00180	Error	-
<a href="#">0x00910009</a>	9502729	Internal error: See C00180	Error	-
<a href="#">0x007b0034</a>	8060980	Internal communication error (DMA)	System fault	-
<a href="#">0x007b0014</a>	8060948	Internal communication error (host MCTRL)	System fault	-
<a href="#">0x007b0036</a>	8060982	Internal communication error (MCTRL host)	System fault	-
<a href="#">0x00910002</a>	9502722	No heartbeat signal detected	System fault	-
<a href="#">0x0090000a</a>	9437194	No parameters for module in MXI1	Error	<a href="#">C00615/2</a>
<a href="#">0x0090000b</a>	9437195	No parameters for module in MXI2	Error	<a href="#">C00615/3</a>
<a href="#">0x00680019</a>	6815769	Combination MXI1/MXI2 not possible	System fault	-
<a href="#">0x0068001f</a>	6815775	Combination of memory module/device not possible	System fault	-
<a href="#">0x00680020</a>	6815776	Combination of module in MXI1/device not possible	System fault	-
<a href="#">0x00680021</a>	6815777	Combination of module in MXI2/device not possible	System fault	-
<a href="#">0x007f0003</a>	8323075	Communication with module in MXI1 interrupted	Information	-
<a href="#">0x007f0004</a>	8323076	Communication with module in MXI2 interrupted	Information	-
<a href="#">0x00920001</a>	9568257	Communication with safety module interrupted	Information	-
<a href="#">0x007f0002</a>	8323074	Communication error between device and device module	No response	<a href="#">C01501</a>
<a href="#">0x0091000e</a>	9502734	Communication task: standstill > 3 s	Error	<a href="#">C01230</a>
<a href="#">0x00770010</a>	7798800	Heatsink: fan is defective	Error	<a href="#">C00610</a>
<a href="#">0x00770000</a>	7798784	Heatsink: temperature > C00122	Warning	<a href="#">C00582</a>
<a href="#">0x0077000a</a>	7798794	Heatsink: thermal detector is defective	Error	<a href="#">C00588</a>
<a href="#">0x00770001</a>	7798785	Heatsink: Overtemperature	Error	-
<a href="#">0x007b0023</a>	8060963	Load encoder: Module selected in C00490 is not available	Error	-
<a href="#">0x006a000d</a>	6946829	Run-time error	Error	-
<a href="#">0x0068000f</a>	6815759	Power section incompatible	System fault	-
<a href="#">0x00680001</a>	6815745	Power section is defective	System fault	-
<a href="#">0x00680009</a>	6815753	Power section is defective	System fault	-
<a href="#">0x007b0042</a>	8060994	Power section is defective	System fault	-
<a href="#">0x00680014</a>	6815764	Power section has been changed	Information or warning locked if the hardware type has also changed.	-
<a href="#">0x00900001</a>	9437185	Lenze setting loaded	Information	-
<a href="#">0x00900004</a>	9437188	Loading of Lenze setting failed	Error	-

hex	dec	Error message	Response (Lenze setting)	Adjustable in
<a href="#">0x00720000</a>	7471104	Read error service register	Error	-
<a href="#">0x00650001</a>	6619137	Logbook: Reset (read error)	Information	-
<a href="#">0x00650002</a>	6619138	Logbook: Reset (version error)	Information	-
<a href="#">0x00650000</a>	6619136	Logbook: Overflow	Information	-
<a href="#">0x00b80010</a>	12058640	Maximum speed exceeded	Information	<a href="#">C02716/3</a>
<a href="#">0x00b80011</a>	12058641	Maximum acceleration exceeded	Information	<a href="#">C02716/3</a>
<a href="#">0x007b004c</a>	8061004	Motor disconnected	No response	<a href="#">C00597</a>
<a href="#">0x007b0007</a>	8060935	Motor: rated current < rated magnetisation current	Information	-
<a href="#">0x007b0002</a>	8060930	Motor: Calculated mutual inductance unrealistic	Information	-
<a href="#">0x007b000a</a>	8060938	Motor: Calculated mutual inductance unrealistic	Information	-
<a href="#">0x007b0001</a>	8060929	Motor: Calculated motor impedance unrealistic	Information	-
<a href="#">0x007b000c</a>	8060940	Motor: Calculated rotor time constant unrealistic	Information	-
<a href="#">0x007b0019</a>	8060953	Motor: Calculated leakage inductance unrealistic	Information	-
<a href="#">0x007b000b</a>	8060939	Motor: Calculated e.m.f. factor unrealistic	Information	-
<a href="#">0x007b000d</a>	8060941	Motor: Calculated flux factor unrealistic	Information	-
<a href="#">0x007b0009</a>	8060937	Motor: Calculated rotor resistance unrealistic	Information	-
<a href="#">0x007b0020</a>	8060960	Motor: actual speed > C00596	Error	<a href="#">C00607</a>
<a href="#">0x007b0006</a>	8060934	Motor: Device current too low for rated magnetisation	Information	-
<a href="#">0x007b0004</a>	8060932	Motor: Phase resistance too high	Information	-
<a href="#">0x0077000f</a>	7798799	Motor: PTC has triggered	No response	<a href="#">C00585</a>
<a href="#">0x007b001e</a>	8060958	Motor: actual current > C00620	Error	<a href="#">C00619</a>
<a href="#">0x00770002</a>	7798786	Motor: temperature > C00121	Warning	<a href="#">C00584</a>
<a href="#">0x0077000c</a>	7798796	Motor: thermal detector is defective	Error	<a href="#">C00594</a>
<a href="#">0x00770003</a>	7798787	Motor: Overtemperature	Error	<a href="#">C00583</a>
<a href="#">0x00780003</a>	7864323	Motor load I*xt > C00120	Error	-
<a href="#">0x00780002</a>	7864322	Motor load I*xt > C00127	Warning	<a href="#">C00606</a>
<a href="#">0x00b80004</a>	12058628	Motor brake: Autom. activated after waiting time has elapsed	Information	-
<a href="#">0x00b80005</a>	12058629	Motor brake: Status monitoring error	Quick stop by trouble	-
<a href="#">0x00b80003</a>	12058627	Motor brake: Angular drift with closed brake too high	Quick stop by trouble	-
<a href="#">0x007b0003</a>	8060931	Motor data are inconsistent	Information	-
<a href="#">0x007b0017</a>	8060951	Motor data are inconsistent	Information	-
<a href="#">0x007b0024</a>	8060964	Motor encoder: Module selected in C00495 is not available	Error	-
<a href="#">0x007b0038</a>	8060984	Motor parameter identification cancelled	Error	-
<a href="#">0x007b0013</a>	8060947	Motor control: Task overflow	System fault	-
<a href="#">0x007b0025</a>	8060965	Motor temperature: Module selected in C01193 is not available	Error	-
<a href="#">0x008c0017</a>	9175063	MXI1: CAN module is missing or incompatible	Error	<a href="#">C00615/2</a>
<a href="#">0x008c0011</a>	9175057	MXI1: Ethernet module is missing or incompatible	Error	<a href="#">C00615/2</a>
<a href="#">0x00680010</a>	6815760	MXI1: Wrong module	System fault	-
<a href="#">0x008c0015</a>	9175061	MXI1: ICM module is missing or incompatible	Error	<a href="#">C00615/2</a>
<a href="#">0x008c0013</a>	9175059	MXI1: Digital frequency module is missing or incompatible	Error	<a href="#">C00615/2</a>
<a href="#">0x008c000d</a>	9175053	MXI1: Module is missing or incompatible	Error	-
<a href="#">0x0068000a</a>	6815754	MXI1: Module is defective or missing	Error	-
<a href="#">0x00680004</a>	6815748	MXI1: Module changed during operation	Warning locked	-
<a href="#">0x00680015</a>	6815765	MXI1: Module has been changed	Information or warning locked if the hardware type has also changed.	-
<a href="#">0x008c000f</a>	9175055	MXI1: PROFIBUS module is missing or incompatible	Error	<a href="#">C00615/2</a>
<a href="#">0x008c0018</a>	9175064	MXI2: CAN module is missing or incompatible	Error	<a href="#">C00615/3</a>
<a href="#">0x008c0012</a>	9175058	MXI2: Ethernet module is missing or incompatible	Error	<a href="#">C00615/3</a>
<a href="#">0x00680011</a>	6815761	MXI2: Wrong module	System fault	-
<a href="#">0x008c0016</a>	9175062	MXI2: ICM module is missing or incompatible	Error	<a href="#">C00615/3</a>
<a href="#">0x008c0014</a>	9175060	MXI2: Digital frequency module is missing or incompatible	Error	<a href="#">C00615/3</a>
<a href="#">0x008c000e</a>	9175054	MXI2: Module is missing or incompatible	Error	-

hex	dec	Error message	Response (Lenze setting)	Adjustable in
<a href="#">0x0068000b</a>	6815755	MXI2: Module is defective or missing	System fault	-
<a href="#">0x00680005</a>	6815749	MXI2: Module changed during operation	Warning locked	-
<a href="#">0x00680016</a>	6815766	MXI2: Module has been changed	Information or warning locked if the hardware type has also changed.	-
<a href="#">0x008c0010</a>	9175056	MXI2: PROFIBUS module is missing or incompatible	Error	<a href="#">C00615/3</a>
<a href="#">0x00b8000a</a>	12058634	Negative direction of rotation limited	Information	<a href="#">C02716/1</a>
<a href="#">0x00b80002</a>	12058626	Negative limit switch has triggered	Quick stop by trouble	-
<a href="#">0x00b80008</a>	12058632	Negative software limit switch overtravelled	Quick stop by trouble	<a href="#">C02716/2</a>
<a href="#">0x00910001</a>	9502721	Mains voltage is switched off	Information	-
<a href="#">0x00910000</a>	9502720	Mains voltage is switched on	Information	-
<a href="#">0x006a0003</a>	6946819	New applications loaded	Information	-
<a href="#">0x00900006</a>	9437190	Saving of parameters failed	Error	-
<a href="#">0x00900000</a>	9437184	Parameter set faulty	Error	-
<a href="#">0x00900003</a>	9437187	Parameter set loaded	Information	-
<a href="#">0x00900002</a>	9437186	Parameter set saved	Information	-
<a href="#">0x00900005</a>	9437189	Parameter set restored	Error	-
<a href="#">0x00900009</a>	9437193	Parameter set: type of standard device has been changed	Information	-
<a href="#">0x00900007</a>	9437191	Parameter set: Version conflict	Error	-
<a href="#">0x006a0015</a>	6946837	PDO mapping (MXI1): Faulty configuration	Error	-
<a href="#">0x006a0016</a>	6946838	PDO mapping (MXI2): Faulty configuration	Error	-
<a href="#">0x007b004a</a>	8061002	Pole position identification cancelled	Error	<a href="#">C00640</a>
<a href="#">0x00910010</a>	9502736	Position value faulty	Error	-
<a href="#">0x00b8000f</a>	12058639	Position target outside the software limit positions	Quick stop by trouble	<a href="#">C02716/2</a>
<a href="#">0x00b80009</a>	12058633	Positive direction of rotation limited	Information	<a href="#">C02716/1</a>
<a href="#">0x00b80001</a>	12058625	Positive limit switch has triggered	Quick stop by trouble	-
<a href="#">0x00b80007</a>	12058631	Positive software limit switch overtravelled	Quick stop by trouble	<a href="#">C02716/2</a>
<a href="#">0x008c0009</a>	9175049	Project not loaded	Error	-
<a href="#">0x008c000a</a>	9175050	Project not available	Error	-
<a href="#">0x00b80019</a>	12058649	Homing mode not allowed	Error	-
<a href="#">0x007b001f</a>	8060959	Resolver: Calculated acceleration unrealistic	Information	-
<a href="#">0x007b0018</a>	8060952	Resolver: Open circuit	Error	-
<a href="#">0x006a001a</a>	6946842	Retain memory of the application faulty	Error	-
<a href="#">0x00b8000e</a>	12058638	Jerk has been limited	Information	<a href="#">C02716/3</a>
<a href="#">0x00680003</a>	6815747	Safety module is defective or missing	System fault	-
<a href="#">0x0068000d</a>	6815757	Safety module is defective or missing	System fault	-
<a href="#">0x00680007</a>	6815751	Safety module has been removed	System fault	-
<a href="#">0x00680018</a>	6815768	Safety module has been changed	Information or warning locked if the hardware type has also changed.	-
<a href="#">0x00920000</a>	9568256	Safety module: Incompatible with setting in C00214	System fault	-
<a href="#">0x00650003</a>	6619139	Memory module missing	Information	-
<a href="#">0x00680002</a>	6815746	Memory module is defective or missing	Error	-
<a href="#">0x0068000c</a>	6815756	Memory module is defective or missing	System fault	-
<a href="#">0x00680006</a>	6815750	Memory module has been removed	System fault	-
<a href="#">0x00680017</a>	6815767	Memory module has been changed	Information or warning locked if the hardware type has also changed.	-
<a href="#">0x0068001c</a>	6815772	Memory module: Faulty file system	Error	-
<a href="#">0x007c0000</a>	8126464	Memory module: file system has been formatted	Information	-
<a href="#">0x007c0001</a>	8126465	Memory module: File system has been restored	Information	-
<a href="#">0x008c001e</a>	9175070	Storage capacity for user parameters exceeded	Error	-
<a href="#">0x00b80000</a>	12058624	PLC configuration invalid	Error	-
<a href="#">0x007d0001</a>	8192001	PLC configuration invalid	Error	-



hex	dec	Error message	Response (Lenze setting)	Adjustable in
<a href="#">0x007b0037</a>	8060983	PLC configuration invalid	Error	-
<a href="#">0x00750006</a>	7667718	PLC configuration invalid	Error	-
<a href="#">0x0068000e</a>	6815758	Control card incompatible	System fault	-
<a href="#">0x00680000</a>	6815744	Control card is defective	System fault	-
<a href="#">0x00680008</a>	6815752	Control card is defective	System fault	-
<a href="#">0x00780008</a>	7864328	Control card is defective (UB18 neg.)	System fault	-
<a href="#">0x00780004</a>	7864324	Control card is defective (UB24)	System fault	-
<a href="#">0x00780006</a>	7864326	Control card is defective (UB8)	System fault	-
<a href="#">0x00780007</a>	7864327	Control card is defective (VCC15 neg.)	System fault	-
<a href="#">0x00780005</a>	7864325	Control card is defective (VCC15)	System fault	-
<a href="#">0x00780009</a>	7864329	Control card is defective (VCC5)	System fault	-
<a href="#">0x006f0000</a>	7274496	Control card: Supply voltage (24 V DC) too low	Fault	-
<a href="#">0x0091000a</a>	9502730	System task 1: Task overflow	System fault	-
<a href="#">0x0091000b</a>	9502731	System task 2: Task overflow	Information	-
<a href="#">0x0091000c</a>	9502732	System task 3: Task overflow	System fault	-
<a href="#">0x0091000d</a>	9502733	System task: Task overflow	Error	-
<a href="#">0x00b80012</a>	12058642	Time-out torque feedforward control brake	Quick stop by trouble	-
<a href="#">0x007b0010</a>	8060944	Overcurrent detected	Error	-
<a href="#">0x006a0005</a>	6946821	UserTask: Overflow	Error	<a href="#">C02111</a>
<a href="#">0x00790002</a>	7929858	Violation of time slice	Error	-
<a href="#">0x00b8000d</a>	12058637	Deceleration has been limited	Information	<a href="#">C02716/3</a>
<a href="#">0x006a001b</a>	6946843	Watchdog cycle is greater than task cycle	Error	-
<a href="#">0x006a0012</a>	6946834	Pointer access in impermissible memory area	Error	-
<a href="#">0x00790001</a>	7929857	Time error - controller interface	System fault	-
<a href="#">0x0077000d</a>	7798797	DC-bus capacitor: thermal detector is defective	Error	<a href="#">C00588</a>
<a href="#">0x007b000e</a>	8060942	DC-bus overvoltage	Fault	<a href="#">C00600</a>
<a href="#">0x007b000f</a>	8060943	DC-bus undervoltage	Fault	-
<a href="#">0x0091000f</a>	9502735	Cyclical task: standstill > 60 s	Information	-

### 13.7.4 Cause & possible remedies

This chapter contains all error messages of the controller operating system in numerical order of the error numbers. The list provides detailed information on the response to the error message as well as information on the cause & possible remedies.



#### Tip!

A list of all error messages of the controller operating system in alphabetical order can be found in the previous chapter "[Short overview \(A-Z\)](#)". (📖 626)



#### Note!

##### Error message "Unknown error"

If the "Unknown error xxxx" error message is indicated in the logbook or in [C00166](#), the reason for the missing plain text is that the error texts required have not been downloaded to the controller during the application download.

- This, for instance, is the case if a device module plugged into the controller has not been included in the Engineer project.
- Remedy: Include the device module, recompile and download the project.

#### Logbook: Overflow [0x00650000]

Module ID (decimal)	Error ID (decimal)
101: Logbook module	0
<b>Reaction</b> (Lenze setting in bold)	
<input type="checkbox"/> None <input type="checkbox"/> System fault <input type="checkbox"/> Fault <input type="checkbox"/> Trouble <input type="checkbox"/> Quick stop by trouble <input type="checkbox"/> Warning locked <input type="checkbox"/> Warning <input checked="" type="checkbox"/> <b>Information</b>	
<b>Cause</b>	<b>Remedy</b>
Too many events/faults have occurred in a very short time. It was therefore not possible to list all of them in the logbook.	Check whether application generates too many error messages.

#### Logbook: Reset (read error) [0x00650001]

Module ID (decimal)	Error ID (decimal)
101: Logbook module	1
<b>Reaction</b> (Lenze setting in bold)	
<input type="checkbox"/> None <input type="checkbox"/> System fault <input type="checkbox"/> Fault <input type="checkbox"/> Trouble <input type="checkbox"/> Quick stop by trouble <input type="checkbox"/> Warning locked <input type="checkbox"/> Warning <input checked="" type="checkbox"/> <b>Information</b>	
<b>Cause</b>	<b>Remedy</b>
The logbook has been reset due to a read error..	-(is irreversible)

#### Logbook: Reset (version error) [0x00650002]

Module ID (decimal)	Error ID (decimal)
101: Logbook module	2
<b>Reaction</b> (Lenze setting in bold)	
<input type="checkbox"/> None <input type="checkbox"/> System fault <input type="checkbox"/> Fault <input type="checkbox"/> Trouble <input type="checkbox"/> Quick stop by trouble <input type="checkbox"/> Warning locked <input type="checkbox"/> Warning <input checked="" type="checkbox"/> <b>Information</b>	
<b>Cause</b>	<b>Remedy</b>
The logbook has been reset due to a version conflict.	-(is irreversible)

**Memory module is missing [0x00650003]**

Module ID (decimal)	Error ID (decimal)
101: Logbook module	3
<b>Reaction</b> (Lenze setting in bold)	
<input type="checkbox"/> None <input type="checkbox"/> System fault <input type="checkbox"/> Fault <input type="checkbox"/> Trouble <input type="checkbox"/> Quick stop by trouble <input type="checkbox"/> Warning locked <input type="checkbox"/> Warning <input checked="" type="checkbox"/> <b>Information</b>	
<b>Cause</b>	<b>Remedy</b>
Memory module is defective or not available.	Use a different memory module.

**Control card is defect [0x00680000]**

Module ID (decimal)	Error ID (decimal)
104: Module identification	0
<b>Reaction</b> (Lenze setting in bold)	
<input type="checkbox"/> None <input checked="" type="checkbox"/> <b>System fault</b> <input type="checkbox"/> Fault <input type="checkbox"/> Trouble <input type="checkbox"/> Quick stop by trouble <input type="checkbox"/> Warning locked <input type="checkbox"/> Warning <input type="checkbox"/> Information	
<b>Cause</b>	<b>Remedy</b>
Operating system could not identify the control card.	Mains switching <ul style="list-style-type: none"> <li>• Please contact Lenze if the error occurs again.</li> </ul>

**Power section is defect [0x00680001]**

Module ID (decimal)	Error ID (decimal)
104: Module identification	1
<b>Reaction</b> (Lenze setting in bold)	
<input type="checkbox"/> None <input checked="" type="checkbox"/> <b>System fault</b> <input type="checkbox"/> Fault <input type="checkbox"/> Trouble <input type="checkbox"/> Quick stop by trouble <input type="checkbox"/> Warning locked <input type="checkbox"/> Warning <input type="checkbox"/> Information	
<b>Cause</b>	<b>Remedy</b>
Operating system could not identify the power section.	Mains switching <ul style="list-style-type: none"> <li>• Please contact Lenze if the error occurs again.</li> </ul>

**Memory module is defect or missing [0x00680002]**

Module ID (decimal)	Error ID (decimal)
104: Module identification	2
<b>Reaction</b> (Lenze setting in bold)	
<input type="checkbox"/> None <input type="checkbox"/> System fault <input checked="" type="checkbox"/> <b>Fault</b> <input type="checkbox"/> Trouble <input type="checkbox"/> Quick stop by trouble <input type="checkbox"/> Warning locked <input type="checkbox"/> Warning <input type="checkbox"/> Information	
<b>Cause</b>	<b>Remedy</b>
Operating system could not identify the memory module.	Mains switching <ul style="list-style-type: none"> <li>• If the error occurs again: Switch off the controller, remove memory module and plug in again, switch on the controller again.</li> <li>• If the error still occurs: Switch off controller and use a different memory module.</li> </ul>

## Safety module is defect or missing [0x00680003]

Module ID (decimal)	Error ID (decimal)
104: Module identification	3
<b>Reaction</b> (Lenze setting in bold)	
<input type="checkbox"/> None <input checked="" type="checkbox"/> <b>System fault</b> <input type="checkbox"/> Fault <input type="checkbox"/> Trouble <input type="checkbox"/> Quick stop by trouble <input type="checkbox"/> Warning locked <input type="checkbox"/> Warning <input type="checkbox"/> Information	
<b>Cause</b>	<b>Remedy</b>
Operating system could not identify the safety module.	Mains switching <ul style="list-style-type: none"> <li>• If the error occurs again: Switch off the controller, remove safety module and plug in again, switch on the controller again.</li> <li>• If the error still occurs: Switch off controller and use a different safety module.</li> </ul>

## MXI1: Module changed during operation [0x00680004]

Module ID (decimal)	Error ID (decimal)
104: Module identification	4
<b>Reaction</b> (Lenze setting in bold)	
<input type="checkbox"/> None <input type="checkbox"/> System fault <input type="checkbox"/> Fault <input type="checkbox"/> Trouble <input type="checkbox"/> Quick stop by trouble <input checked="" type="checkbox"/> <b>Warning locked</b> <input type="checkbox"/> Warning <input type="checkbox"/> Information	
<b>Cause</b>	<b>Remedy</b>
It was tried to plug an extension module into module slot MXI1, which is not "Hot-plug"-able.	Plug in valid module and switch on mains. <ul style="list-style-type: none"> <li>• Through mains switching, the system accepts modules without "hot plug" capability in the following switch-on phase.</li> </ul>

## MXI2: Module changed during operation [0x00680005]

Module ID (decimal)	Error ID (decimal)
104: Module identification	5
<b>Reaction</b> (Lenze setting in bold)	
<input type="checkbox"/> None <input type="checkbox"/> System fault <input type="checkbox"/> Fault <input type="checkbox"/> Trouble <input type="checkbox"/> Quick stop by trouble <input checked="" type="checkbox"/> <b>Warning locked</b> <input type="checkbox"/> Warning <input type="checkbox"/> Information	
<b>Cause</b>	<b>Remedy</b>
It was tried to plug an extension module into module slot MXI2, which is not "Hot-plug"-able.	Plug in valid module and switch on mains. <ul style="list-style-type: none"> <li>• Through mains switching, the system accepts modules without "hot plug" capability in the following switch-on phase.</li> </ul>

## Memory module has been removed [0x00680006]

Module ID (decimal)	Error ID (decimal)
104: Module identification	6
<b>Reaction</b> (Lenze setting in bold)	
<input type="checkbox"/> None <input checked="" type="checkbox"/> <b>System fault</b> <input type="checkbox"/> Fault <input type="checkbox"/> Trouble <input type="checkbox"/> Quick stop by trouble <input type="checkbox"/> Warning locked <input type="checkbox"/> Warning <input type="checkbox"/> Information	
<b>Cause</b>	<b>Remedy</b>
You have tried to remove or change the memory module during operation.	Switch off the controller, plug in memory module and switch on the controller again. <ul style="list-style-type: none"> <li>• If the error occurs again, the memory module is defective and must be replaced.</li> </ul>

**Safety module has been removed [0x00680007]**

Module ID (decimal)	Error ID (decimal)
104: Module identification	7
<b>Reaction</b> (Lenze setting in bold)	
<input type="checkbox"/> None <input checked="" type="checkbox"/> <b>System fault</b> <input type="checkbox"/> Fault <input type="checkbox"/> Trouble <input type="checkbox"/> Quick stop by trouble <input type="checkbox"/> Warning locked <input type="checkbox"/> Warning <input type="checkbox"/> Information	
<b>Cause</b>	<b>Remedy</b>
You have tried to remove or change the safety module during operation.	Switch off the controller, plug in safety module and switch on the controller again. <ul style="list-style-type: none"> <li>• If the error occurs again, the safety module is defective and must be replaced.</li> </ul>

**Control card is defect [0x00680008]**

Module ID (decimal)	Error ID (decimal)
104: Module identification	8
<b>Reaction</b> (Lenze setting in bold)	
<input type="checkbox"/> None <input checked="" type="checkbox"/> <b>System fault</b> <input type="checkbox"/> Fault <input type="checkbox"/> Trouble <input type="checkbox"/> Quick stop by trouble <input type="checkbox"/> Warning locked <input type="checkbox"/> Warning <input type="checkbox"/> Information	
<b>Cause</b>	<b>Remedy</b>
Operating system could not identify the control card.	Please contact Lenze.

**Power section is defect [0x00680009]**

Module ID (decimal)	Error ID (decimal)
104: Module identification	9
<b>Reaction</b> (Lenze setting in bold)	
<input type="checkbox"/> None <input checked="" type="checkbox"/> <b>System fault</b> <input type="checkbox"/> Fault <input type="checkbox"/> Trouble <input type="checkbox"/> Quick stop by trouble <input type="checkbox"/> Warning locked <input type="checkbox"/> Warning <input type="checkbox"/> Information	
<b>Cause</b>	<b>Remedy</b>
Operating system could not identify the power section.	Please contact Lenze.

**MX11: Module is defect or missing [0x0068000a]**

Module ID (decimal)	Error ID (decimal)
104: Module identification	10
<b>Reaction</b> (Lenze setting in bold)	
<input type="checkbox"/> None <input type="checkbox"/> System fault <input checked="" type="checkbox"/> <b>Fault</b> <input type="checkbox"/> Trouble <input type="checkbox"/> Quick stop by trouble <input type="checkbox"/> Warning locked <input type="checkbox"/> Warning <input type="checkbox"/> Information	
<b>Cause</b>	<b>Remedy</b>
Operating system could not identify the extension module in module slot MX11.	<ul style="list-style-type: none"> <li>• Use a different extension module.</li> <li>• Please contact Lenze.</li> </ul>

**MX12: Module is defect or missing [0x0068000b]**

Module ID (decimal)	Error ID (decimal)
104: Module identification	11
<b>Reaction</b> (Lenze setting in bold)	
<input type="checkbox"/> None <input checked="" type="checkbox"/> <b>System fault</b> <input type="checkbox"/> Fault <input type="checkbox"/> Trouble <input type="checkbox"/> Quick stop by trouble <input type="checkbox"/> Warning locked <input type="checkbox"/> Warning <input type="checkbox"/> Information	
<b>Cause</b>	<b>Remedy</b>
Operating system could not identify the extension module in module slot MX12.	<ul style="list-style-type: none"> <li>• Use a different extension module.</li> <li>• Please contact Lenze.</li> </ul>

**Memory module is defect or missing [0x0068000c]**

Module ID (decimal)	Error ID (decimal)
104: Module identification	12
<b>Reaction</b> (Lenze setting in bold)	
<input type="checkbox"/> None <input checked="" type="checkbox"/> <b>System fault</b> <input type="checkbox"/> Fault <input type="checkbox"/> Trouble <input type="checkbox"/> Quick stop by trouble <input type="checkbox"/> Warning locked <input type="checkbox"/> Warning <input type="checkbox"/> Information	
<b>Cause</b>	<b>Remedy</b>
Operating system could not identify the memory module.	<ul style="list-style-type: none"> <li>• Use a different memory module.</li> <li>• Please contact Lenze.</li> </ul>

**Safety module is defect or missing [0x0068000d]**

Module ID (decimal)	Error ID (decimal)
104: Module identification	13
<b>Reaction</b> (Lenze setting in bold)	
<input type="checkbox"/> None <input checked="" type="checkbox"/> <b>System fault</b> <input type="checkbox"/> Fault <input type="checkbox"/> Trouble <input type="checkbox"/> Quick stop by trouble <input type="checkbox"/> Warning locked <input type="checkbox"/> Warning <input type="checkbox"/> Information	
<b>Cause</b>	<b>Remedy</b>
Operating system could not identify the safety module.	<ul style="list-style-type: none"> <li>• Use a different safety module.</li> <li>• Please contact Lenze.</li> </ul>

**Control card incompatible [0x0068000e]**

Module ID (decimal)	Error ID (decimal)
104: Module identification	14
<b>Reaction</b> (Lenze setting in bold)	
<input type="checkbox"/> None <input checked="" type="checkbox"/> <b>System fault</b> <input type="checkbox"/> Fault <input type="checkbox"/> Trouble <input type="checkbox"/> Quick stop by trouble <input type="checkbox"/> Warning locked <input type="checkbox"/> Warning <input type="checkbox"/> Information	
<b>Cause</b>	<b>Remedy</b>
The control card is not supported by the operating system.	Please contact Lenze.

**Power section incompatible [0x0068000f]**

Module ID (decimal)	Error ID (decimal)
104: Module identification	15
<b>Reaction</b> (Lenze setting in bold)	
<input type="checkbox"/> None <input checked="" type="checkbox"/> <b>System fault</b> <input type="checkbox"/> Fault <input type="checkbox"/> Trouble <input type="checkbox"/> Quick stop by trouble <input type="checkbox"/> Warning locked <input type="checkbox"/> Warning <input type="checkbox"/> Information	
<b>Cause</b>	<b>Remedy</b>
The power section is not supported by the operating system.	Please contact Lenze.

**MXI1: Wrong module [0x00680010]**

Module ID (decimal)	Error ID (decimal)
104: Module identification	16
<b>Reaction</b> (Lenze setting in bold)	
<input type="checkbox"/> None <input checked="" type="checkbox"/> <b>System fault</b> <input type="checkbox"/> Fault <input type="checkbox"/> Trouble <input type="checkbox"/> Quick stop by trouble <input type="checkbox"/> Warning locked <input type="checkbox"/> Warning <input type="checkbox"/> Information	
<b>Cause</b>	<b>Remedy</b>
The extension module in module slot MXI1 is not supported by the operating system.	<ul style="list-style-type: none"> <li>• Use a different module.</li> <li>• Please contact Lenze.</li> </ul>

**MXI2: Wrong module [0x00680011]**

Module ID (decimal)	Error ID (decimal)
104: Module identification	17
<b>Reaction</b> (Lenze setting in bold)	
<input type="checkbox"/> None <input checked="" type="checkbox"/> <b>System fault</b> <input type="checkbox"/> Fault <input type="checkbox"/> Trouble <input type="checkbox"/> Quick stop by trouble <input type="checkbox"/> Warning locked <input type="checkbox"/> Warning <input type="checkbox"/> Information	
<b>Cause</b>	<b>Remedy</b>
The extension module in module slot MXI2 is not supported by the operating system.	<ul style="list-style-type: none"> <li>• Use a different module.</li> <li>• Please contact Lenze.</li> </ul>

**Incorrect memory module [0x00680012]**

Module ID (decimal)	Error ID (decimal)
104: Module identification	18
<b>Reaction</b> (Lenze setting in bold)	
<input type="checkbox"/> None <input checked="" type="checkbox"/> <b>System fault</b> <input type="checkbox"/> Fault <input type="checkbox"/> Trouble <input type="checkbox"/> Quick stop by trouble <input type="checkbox"/> Warning locked <input type="checkbox"/> Warning <input type="checkbox"/> Information	
<b>Cause</b>	<b>Remedy</b>
The memory module is not supported by the operating system.	<ul style="list-style-type: none"> <li>• Use a different module.</li> <li>• Please contact Lenze.</li> </ul>

**Incorrect safety module [0x00680013]**

Module ID (decimal)	Error ID (decimal)
104: Module identification	19
<b>Reaction</b> (Lenze setting in bold)	
<input type="checkbox"/> None <input checked="" type="checkbox"/> <b>System fault</b> <input type="checkbox"/> Fault <input type="checkbox"/> Trouble <input type="checkbox"/> Quick stop by trouble <input type="checkbox"/> Warning locked <input type="checkbox"/> Warning <input type="checkbox"/> Information	
<b>Cause</b>	<b>Remedy</b>
The safety module is not supported by the operating system.	<ul style="list-style-type: none"> <li>• Use a different module.</li> <li>• Please contact Lenze.</li> </ul>

**Power section was changed [0x00680014]**

Module ID (decimal)	Error ID (decimal)
104: Module identification	20
<b>Reaction</b> (Lenze setting in bold)	
<input type="checkbox"/> None <input type="checkbox"/> System fault <input type="checkbox"/> Fault <input type="checkbox"/> Trouble <input type="checkbox"/> Quick stop by trouble <input checked="" type="checkbox"/> <b>Warning locked</b> <input type="checkbox"/> Warning <input checked="" type="checkbox"/> <b>Information</b>	
<b>Cause</b>	<b>Remedy</b>
The power section has been changed since the last mains switching.	(Only information or warning locked if the hardware type has also changed.)

**MXI1: Module has been changed [0x00680015]**

Module ID (decimal)	Error ID (decimal)
104: Module identification	21
<b>Reaction</b> (Lenze setting in bold)	
<input type="checkbox"/> None <input type="checkbox"/> System fault <input type="checkbox"/> Fault <input type="checkbox"/> Trouble <input type="checkbox"/> Quick stop by trouble <input checked="" type="checkbox"/> <b>Warning locked</b> <input type="checkbox"/> Warning <input checked="" type="checkbox"/> <b>Information</b>	
<b>Cause</b>	<b>Remedy</b>
The extension module in module slot MXI1 has been changed since the last mains switching.	(Only information or warning locked if the hardware type has also changed.)

**MXI2: Module has been changed [0x00680016]**

Module ID (decimal)	Error ID (decimal)
104: Module identification	22
<b>Reaction</b> (Lenze setting in bold)	
<input type="checkbox"/> None <input type="checkbox"/> System fault <input type="checkbox"/> Fault <input type="checkbox"/> Trouble <input type="checkbox"/> Quick stop by trouble <input checked="" type="checkbox"/> <b>Warning locked</b> <input type="checkbox"/> Warning <input checked="" type="checkbox"/> <b>Information</b>	
<b>Cause</b>	<b>Remedy</b>
The extension module in module slot MXI2 has been changed since the last mains switching.	(Only information or warning locked if the hardware type has also changed.)

**Memory module has been changed [0x00680017]**

Module ID (decimal)	Error ID (decimal)
104: Module identification	23
<b>Reaction</b> (Lenze setting in bold)	
<input type="checkbox"/> None <input type="checkbox"/> System fault <input type="checkbox"/> Fault <input type="checkbox"/> Trouble <input type="checkbox"/> Quick stop by trouble <input checked="" type="checkbox"/> <b>Warning locked</b> <input type="checkbox"/> Warning <input checked="" type="checkbox"/> <b>Information</b>	
<b>Cause</b>	<b>Remedy</b>
The memory module has been changed since the last mains switching.	(Only information or warning locked if the hardware type has also changed.)

**Safety module has been changed [0x00680018]**

Module ID (decimal)	Error ID (decimal)
104: Module identification	24
<b>Reaction</b> (Lenze setting in bold)	
<input type="checkbox"/> None <input type="checkbox"/> System fault <input type="checkbox"/> Fault <input type="checkbox"/> Trouble <input type="checkbox"/> Quick stop by trouble <input checked="" type="checkbox"/> <b>Warning locked</b> <input type="checkbox"/> Warning <input checked="" type="checkbox"/> <b>Information</b>	
<b>Cause</b>	<b>Remedy</b>
The safety module has been changed since the last mains switching.	(Only information or warning locked if the hardware type has also changed.)

**Combination MXI1/MXI2 not possible [0x00680019]**

Module ID (decimal)	Error ID (decimal)
104: Module identification	25
<b>Reaction</b> (Lenze setting in bold)	
<input type="checkbox"/> None <input checked="" type="checkbox"/> <b>System fault</b> <input type="checkbox"/> Fault <input type="checkbox"/> Trouble <input type="checkbox"/> Quick stop by trouble <input type="checkbox"/> Warning locked <input type="checkbox"/> Warning <input type="checkbox"/> Information	
<b>Cause</b>	<b>Remedy</b>
Extension modules which are not supported in this combination are plugged into module slots MXI1 & MXI2.	Create permitted module combination.

**Firmware has been changed [0x0068001a]**

Module ID (decimal)	Error ID (decimal)
104: Module identification	26
<b>Reaction</b> (Lenze setting in bold)	
<input type="checkbox"/> None <input type="checkbox"/> System fault <input type="checkbox"/> Fault <input type="checkbox"/> Trouble <input type="checkbox"/> Quick stop by trouble <input type="checkbox"/> Warning locked <input type="checkbox"/> Warning <input checked="" type="checkbox"/> <b>Information</b>	
<b>Cause</b>	<b>Remedy</b>
The firmware of the operating system has been updated.	- (Information only)



**Electronic nameplate: Communication error [0x0068001b]**

Module ID (decimal)	Error ID (decimal)
104: Module identification	27
<b>Reaction</b> (Lenze setting in bold)	
<input type="checkbox"/> None <input type="checkbox"/> System fault <input type="checkbox"/> Fault <input type="checkbox"/> Trouble <input type="checkbox"/> Quick stop by trouble <input type="checkbox"/> Warning locked <input checked="" type="checkbox"/> <b>Warning</b> <input type="checkbox"/> Information	
<b>Cause</b>	<b>Remedy</b>
Communication with the electronic nameplate is interrupted, the data could not be read.	Check correct connection of the encoder cable.

**Memory module: Faulty file system [0x0068001c]**

Module ID (decimal)	Error ID (decimal)
104: Module identification	28
<b>Reaction</b> (Lenze setting in bold)	
<input type="checkbox"/> None <input type="checkbox"/> System fault <input checked="" type="checkbox"/> <b>Fault</b> <input type="checkbox"/> Trouble <input type="checkbox"/> Quick stop by trouble <input type="checkbox"/> Warning locked <input type="checkbox"/> Warning <input type="checkbox"/> Information	
<b>Cause</b>	<b>Remedy</b>
Memory module is plugged in incorrectly or is defective.	<ul style="list-style-type: none"> <li>• Plug in the memory module correctly.</li> <li>• Exchange defective memory module.</li> </ul>

**Electronic nameplate: Checksum error [0x0068001d]**

Module ID (decimal)	Error ID (decimal)
104: Module identification	29
<b>Reaction</b> (Lenze setting in bold)	
<input type="checkbox"/> None <input type="checkbox"/> System fault <input type="checkbox"/> Fault <input type="checkbox"/> Trouble <input type="checkbox"/> Quick stop by trouble <input type="checkbox"/> Warning locked <input checked="" type="checkbox"/> <b>Warning</b> <input type="checkbox"/> Information	
<b>Cause</b>	<b>Remedy</b>
The checksum of the electronic nameplate is defective.	Please contact Lenze.

**Firmware is incompatible with control card [0x0068001e]**

Module ID (decimal)	Error ID (decimal)
104: Module identification	30
<b>Reaction</b> (Lenze setting in bold)	
<input type="checkbox"/> None <input checked="" type="checkbox"/> <b>System fault</b> <input type="checkbox"/> Fault <input type="checkbox"/> Trouble <input type="checkbox"/> Quick stop by trouble <input type="checkbox"/> Warning locked <input type="checkbox"/> Warning <input type="checkbox"/> Information	
<b>Cause</b>	<b>Remedy</b>
Firmware is not compatible with the hardware.	Import the compatible firmware.

**Combination memory module/device not possible [0x0068001f]**

Module ID (decimal)	Error ID (decimal)
104: Module identification	31
<b>Reaction</b> (Lenze setting in bold)	
<input type="checkbox"/> None <input checked="" type="checkbox"/> <b>System fault</b> <input type="checkbox"/> Fault <input type="checkbox"/> Trouble <input type="checkbox"/> Quick stop by trouble <input type="checkbox"/> Warning locked <input type="checkbox"/> Warning <input type="checkbox"/> Information	
<b>Cause</b>	<b>Remedy</b>
The memory module used is not supported by the controller according to the license model.	Plug in supported module and switch the mains. <ul style="list-style-type: none"> <li>• The 9400 HighLine supports the MM220 (licence: Motion Control HighLevel) and MM330 memory modules (licence: Motion Control TopLevel).</li> </ul>

-----  
**Combination of module in MXI1/device not possible [0x00680020]**

Module ID (decimal)	Error ID (decimal)
104: Module identification	32
<b>Reaction</b> (Lenze setting in bold)	
<input type="checkbox"/> None <input checked="" type="checkbox"/> <b>System fault</b> <input type="checkbox"/> Fault <input type="checkbox"/> Trouble <input type="checkbox"/> Quick stop by trouble <input type="checkbox"/> Warning locked <input type="checkbox"/> Warning <input type="checkbox"/> Information	
<b>Cause</b>	<b>Remedy</b>
The extension module in module slot MXI1 is not supported by the controller.	<ul style="list-style-type: none"> <li>• Remove the extension module and switch the mains.</li> <li>• Plug in supported extension module and switch the mains.</li> </ul>

**Combination of module in MXI2/device not possible [0x00680021]**

Module ID (decimal)	Error ID (decimal)
104: Module identification	33
<b>Reaction</b> (Lenze setting in bold)	
<input type="checkbox"/> None <input checked="" type="checkbox"/> <b>System fault</b> <input type="checkbox"/> Fault <input type="checkbox"/> Trouble <input type="checkbox"/> Quick stop by trouble <input type="checkbox"/> Warning locked <input type="checkbox"/> Warning <input type="checkbox"/> Information	
<b>Cause</b>	<b>Remedy</b>
The extension module in module slot MXI2 is not supported by the controller.	<ul style="list-style-type: none"> <li>• Remove the extension module and switch the mains.</li> <li>• Plug in supported extension module and switch the mains.</li> </ul>

**Real-time clock is defective [0x00680022]**

Module ID (decimal)	Error ID (decimal)
104: Module identification	34
<b>Reaction</b> (Lenze setting in bold)	
<input type="checkbox"/> None <input type="checkbox"/> System fault <input type="checkbox"/> Fault <input type="checkbox"/> Trouble <input type="checkbox"/> Quick stop by trouble <input checked="" type="checkbox"/> <b>Warning locked</b> <input type="checkbox"/> Warning <input type="checkbox"/> Information	
<b>Cause</b>	<b>Remedy</b>
Device error: The clock integrated in the MM440 memory module is defective.	<ul style="list-style-type: none"> <li>• Replacing the memory module.</li> <li>• Please contact Lenze.</li> </ul>

**Real-time clock: Change battery [0x00680023]**

Module ID (decimal)	Error ID (decimal)
104: Module identification	35
<b>Reaction</b> (Lenze setting in bold)	
<input type="checkbox"/> None <input type="checkbox"/> System fault <input type="checkbox"/> Fault <input type="checkbox"/> Trouble <input type="checkbox"/> Quick stop by trouble <input checked="" type="checkbox"/> <b>Warning locked</b> <input type="checkbox"/> Warning <input type="checkbox"/> Information	
<b>Cause</b>	<b>Remedy</b>
The battery in the clock integrated in the MM440 memory module is low. The clock is expected to fail soon.	Replacing the memory module.

## Real-time clock: Battery empty, time lost [0x00680024]

Module ID (decimal)	Error ID (decimal)
104: Module identification	36
<b>Reaction</b> (Lenze setting in bold)	
<input type="checkbox"/> None <input type="checkbox"/> System fault <input type="checkbox"/> Fault <input type="checkbox"/> Trouble <input type="checkbox"/> Quick stop by trouble <input checked="" type="checkbox"/> <b>Warning locked</b> <input type="checkbox"/> Warning <input type="checkbox"/> Information	
<b>Cause</b>	<b>Remedy</b>
The battery integrated in the clock in the MM440 memory module is empty. The clock has been reset to its initial value (01.01.1970 - 00:00:00 o'clock).	<ul style="list-style-type: none"> <li>• If the memory module is used for the first time, restart the controller to initialise the memory module.</li> <li>• If the problem occurs again, replace the memory module.</li> </ul>

## Code refresh [0x00690000]

Module ID (decimal)	Error ID (decimal)
105: Error check of the program memory during runtime	0
<b>Reaction</b> (Lenze setting in bold)	
<input type="checkbox"/> None <input checked="" type="checkbox"/> <b>System fault</b> <input type="checkbox"/> Fault <input type="checkbox"/> Trouble <input type="checkbox"/> Quick stop by trouble <input type="checkbox"/> Warning locked <input type="checkbox"/> Warning <input type="checkbox"/> Information	
<b>Cause</b>	<b>Remedy</b>
Serious device error or component failure.	Switch the controller off and then on again. <ul style="list-style-type: none"> <li>• Please contact Lenze if the problem occurs again.</li> </ul>

## Internal error (memory area - logbook) [0x00690001]

Module ID (decimal)	Error ID (decimal)
105: Error check of the program memory during runtime	1
<b>Reaction</b> (Lenze setting in bold)	
<input type="checkbox"/> None <input checked="" type="checkbox"/> <b>System fault</b> <input type="checkbox"/> Fault <input type="checkbox"/> Trouble <input type="checkbox"/> Quick stop by trouble <input type="checkbox"/> Warning locked <input type="checkbox"/> Warning <input type="checkbox"/> Information	
<b>Cause</b>	<b>Remedy</b>
Serious device error or component failure.	Switch the controller off and then on again. <ul style="list-style-type: none"> <li>• Please contact Lenze if the problem occurs again.</li> </ul>

## Internal error (LDS instance data) [0x00690002]

Module ID (decimal)	Error ID (decimal)
105: Error check of the program memory during runtime	2
<b>Reaction</b> (Lenze setting in bold)	
<input type="checkbox"/> None <input checked="" type="checkbox"/> <b>System fault</b> <input type="checkbox"/> Fault <input type="checkbox"/> Trouble <input type="checkbox"/> Quick stop by trouble <input type="checkbox"/> Warning locked <input type="checkbox"/> Warning <input type="checkbox"/> Information	
<b>Cause</b>	<b>Remedy</b>
Serious device error or component failure.	Switch the controller off and then on again. <ul style="list-style-type: none"> <li>• Please contact Lenze if the problem occurs again.</li> </ul>

## Internal error (LDS tasks) [0x00690003]

Module ID (decimal)	Error ID (decimal)
105: Error check of the program memory during runtime	3
<b>Reaction</b> (Lenze setting in bold)	
<input type="checkbox"/> None <input checked="" type="checkbox"/> <b>System fault</b> <input type="checkbox"/> Fault <input type="checkbox"/> Trouble <input type="checkbox"/> Quick stop by trouble <input type="checkbox"/> Warning locked <input type="checkbox"/> Warning <input type="checkbox"/> Information	
<b>Cause</b>	<b>Remedy</b>
Serious device error or component failure.	Switch the controller off and then on again. • Please contact Lenze if the problem occurs again.

## Internal error (storage blocks) [0x00690004]

Module ID (decimal)	Error ID (decimal)
105: Error check of the program memory during runtime	4
<b>Reaction</b> (Lenze setting in bold)	
<input type="checkbox"/> None <input checked="" type="checkbox"/> <b>System fault</b> <input type="checkbox"/> Fault <input type="checkbox"/> Trouble <input type="checkbox"/> Quick stop by trouble <input type="checkbox"/> Warning locked <input type="checkbox"/> Warning <input type="checkbox"/> Information	
<b>Cause</b>	<b>Remedy</b>
Serious device error or component failure.	Switch the controller off and then on again. • Please contact Lenze if the problem occurs again.

## Internal error (task queue) [0x00690005]

Module ID (decimal)	Error ID (decimal)
105: Error check of the program memory during runtime	5
<b>Reaction</b> (Lenze setting in bold)	
<input type="checkbox"/> None <input checked="" type="checkbox"/> <b>System fault</b> <input type="checkbox"/> Fault <input type="checkbox"/> Trouble <input type="checkbox"/> Quick stop by trouble <input type="checkbox"/> Warning locked <input type="checkbox"/> Warning <input type="checkbox"/> Information	
<b>Cause</b>	<b>Remedy</b>
Serious device error or component failure.	Switch the controller off and then on again. • Please contact Lenze if the problem occurs again.

## Internal error (message memory) [0x00690006]

Module ID (decimal)	Error ID (decimal)
105: Error check of the program memory during runtime	6
<b>Reaction</b> (Lenze setting in bold)	
<input type="checkbox"/> None <input checked="" type="checkbox"/> <b>System fault</b> <input type="checkbox"/> Fault <input type="checkbox"/> Trouble <input type="checkbox"/> Quick stop by trouble <input type="checkbox"/> Warning locked <input type="checkbox"/> Warning <input type="checkbox"/> Information	
<b>Cause</b>	<b>Remedy</b>
Serious device error or component failure.	Switch the controller off and then on again. • Please contact Lenze if the problem occurs again.

## Internal error (message queue) [0x00690007]

Module ID (decimal)	Error ID (decimal)
105: Error check of the program memory during runtime	7
<b>Reaction</b> (Lenze setting in bold)	
<input type="checkbox"/> None <input checked="" type="checkbox"/> <b>System fault</b> <input type="checkbox"/> Fault <input type="checkbox"/> Trouble <input type="checkbox"/> Quick stop by trouble <input type="checkbox"/> Warning locked <input type="checkbox"/> Warning <input type="checkbox"/> Information	
<b>Cause</b>	<b>Remedy</b>
Serious device error or component failure.	Switch the controller off and then on again. • Please contact Lenze if the problem occurs again.

**Internal error (name data base) [0x00690008]**

Module ID (decimal)	Error ID (decimal)
105: Error check of the program memory during runtime	8
<b>Reaction</b> (Lenze setting in bold)	
<input type="checkbox"/> None <input checked="" type="checkbox"/> <b>System fault</b> <input type="checkbox"/> Fault <input type="checkbox"/> Trouble <input type="checkbox"/> Quick stop by trouble <input type="checkbox"/> Warning locked <input type="checkbox"/> Warning <input type="checkbox"/> Information	
<b>Cause</b>	<b>Remedy</b>
Serious device error or component failure.	Switch the controller off and then on again. • Please contact Lenze if the problem occurs again.

**Internal error (event mechanism) [0x00690009]**

Module ID (decimal)	Error ID (decimal)
105: Error check of the program memory during runtime	9
<b>Reaction</b> (Lenze setting in bold)	
<input type="checkbox"/> None <input checked="" type="checkbox"/> <b>System fault</b> <input type="checkbox"/> Fault <input type="checkbox"/> Trouble <input type="checkbox"/> Quick stop by trouble <input type="checkbox"/> Warning locked <input type="checkbox"/> Warning <input type="checkbox"/> Information	
<b>Cause</b>	<b>Remedy</b>
Serious device error or component failure.	Switch the controller off and then on again. • Please contact Lenze if the problem occurs again.

**Internal error (event mechanism) [0x0069000a]**

Module ID (decimal)	Error ID (decimal)
105: Error check of the program memory during runtime	10
<b>Reaction</b> (Lenze setting in bold)	
<input type="checkbox"/> None <input checked="" type="checkbox"/> <b>System fault</b> <input type="checkbox"/> Fault <input type="checkbox"/> Trouble <input type="checkbox"/> Quick stop by trouble <input type="checkbox"/> Warning locked <input type="checkbox"/> Warning <input type="checkbox"/> Information	
<b>Cause</b>	<b>Remedy</b>
Serious device error or component failure.	Switch the controller off and then on again. • Please contact Lenze if the problem occurs again.

**Internal error (semaphores) [0x0069000b]**

Module ID (decimal)	Error ID (decimal)
105: Error check of the program memory during runtime	11
<b>Reaction</b> (Lenze setting in bold)	
<input type="checkbox"/> None <input checked="" type="checkbox"/> <b>System fault</b> <input type="checkbox"/> Fault <input type="checkbox"/> Trouble <input type="checkbox"/> Quick stop by trouble <input type="checkbox"/> Warning locked <input type="checkbox"/> Warning <input type="checkbox"/> Information	
<b>Cause</b>	<b>Remedy</b>
Serious device error or component failure.	Switch the controller off and then on again. • Please contact Lenze if the problem occurs again.

**Internal error (semaphores) [0x0069000c]**

Module ID (decimal)	Error ID (decimal)
105: Error check of the program memory during runtime	12
<b>Reaction</b> (Lenze setting in bold)	
<input type="checkbox"/> None <input checked="" type="checkbox"/> <b>System fault</b> <input type="checkbox"/> Fault <input type="checkbox"/> Trouble <input type="checkbox"/> Quick stop by trouble <input type="checkbox"/> Warning locked <input type="checkbox"/> Warning <input type="checkbox"/> Information	
<b>Cause</b>	<b>Remedy</b>
Serious device error or component failure.	Switch the controller off and then on again. • Please contact Lenze if the problem occurs again.

**Internal error (file system lifetime) [0x0069000d]**

Module ID (decimal)	Error ID (decimal)
105: Error check of the program memory during runtime	13
<b>Reaction (Lenze setting in bold)</b>	
<input type="checkbox"/> None <input type="checkbox"/> System fault <input type="checkbox"/> Fault <input type="checkbox"/> Trouble <input type="checkbox"/> Quick stop by trouble <input type="checkbox"/> Warning locked <input checked="" type="checkbox"/> <b>Warning</b> <input type="checkbox"/> Information	
<b>Cause</b>	
The maximum number of permissible writing cycles has been reached for the memory module.	<b>Remedy</b>
	Replace memory module, otherwise data may get lost.

**General error in the application [0x006a0000]**

Module ID (decimal)	Error ID (decimal)
106: Runtime environment for IEC 61131-3 programs	0
<b>Reaction (Lenze setting in bold)</b>	
<input type="checkbox"/> None <input type="checkbox"/> System fault <input checked="" type="checkbox"/> <b>Fault</b> <input type="checkbox"/> Trouble <input type="checkbox"/> Quick stop by trouble <input type="checkbox"/> Warning locked <input type="checkbox"/> Warning <input type="checkbox"/> Information	
<b>Cause</b>	
General application error.	<b>Remedy</b>
	Mains switching. Transmit the application to the controller again. <ul style="list-style-type: none"> <li>• Please contact Lenze if the problem occurs again.</li> </ul>

**Faulty program download [0x006a0001]**

Module ID (decimal)	Error ID (decimal)
106: Runtime environment for IEC 61131-3 programs	1
<b>Reaction (Lenze setting in bold)</b>	
<input type="checkbox"/> None <input type="checkbox"/> System fault <input checked="" type="checkbox"/> <b>Fault</b> <input type="checkbox"/> Trouble <input type="checkbox"/> Quick stop by trouble <input type="checkbox"/> Warning locked <input type="checkbox"/> Warning <input type="checkbox"/> Information	
<b>Cause</b>	
Faulty transmission of the application to the controller (checksum error).	<b>Remedy</b>
	Repeat transmission.

**Fault during the update of the inputs and outputs [0x006a0002]**

Module ID (decimal)	Error ID (decimal)
106: Runtime environment for IEC 61131-3 programs	2
<b>Reaction (Lenze setting in bold)</b>	
<input type="checkbox"/> None <input type="checkbox"/> System fault <input checked="" type="checkbox"/> <b>Fault</b> <input type="checkbox"/> Trouble <input type="checkbox"/> Quick stop by trouble <input type="checkbox"/> Warning locked <input type="checkbox"/> Warning <input type="checkbox"/> Information	
<b>Cause</b>	
Internal error	<b>Remedy</b>
	Mains switching. Transmit the application to the controller again. <ul style="list-style-type: none"> <li>• Please contact Lenze if the problem occurs again.</li> </ul>

## New application loaded [0x006a0003]

Module ID (decimal)	Error ID (decimal)
106: Runtime environment for IEC 61131-3 programs	3
<b>Reaction</b> (Lenze setting in bold)	
<input type="checkbox"/> None <input type="checkbox"/> System fault <input type="checkbox"/> Fault <input type="checkbox"/> Trouble <input type="checkbox"/> Quick stop by trouble <input type="checkbox"/> Warning locked <input type="checkbox"/> Warning <input checked="" type="checkbox"/> <b>Information</b>	
<b>Cause</b>	<b>Remedy</b>
Application has been changed by transmission from Engineer or loading from the memory module.	- (Information only)

## ApplicationTask: Overflow [0x006a0004]

Module ID (decimal)	Error ID (decimal)
106: Runtime environment for IEC 61131-3 programs	4
<b>Reaction</b> (Lenze setting in bold)	
<input type="checkbox"/> None <input type="checkbox"/> System fault <input checked="" type="checkbox"/> <b>Fault</b> <input type="checkbox"/> Trouble <input checked="" type="checkbox"/> Quick stop by trouble <input type="checkbox"/> Warning locked <input type="checkbox"/> Warning <input type="checkbox"/> Information	
Setting: <a href="#">C02111</a> ( <input checked="" type="checkbox"/> Adjustable response)	
<b>Cause</b>	<b>Remedy</b>
Program runtime in Application task is too high.	Reduce program runtime by means of: <ul style="list-style-type: none"> <li>• Omitting functions (e.g. by reducing the number of active FBs).</li> <li>• Optimisation of functions to the calculating time.</li> </ul>

## UserTask: Overflow [0x006a0005]

Module ID (decimal)	Error ID (decimal)
106: Runtime environment for IEC 61131-3 programs	5
<b>Reaction</b> (Lenze setting in bold)	
<input type="checkbox"/> None <input type="checkbox"/> System fault <input checked="" type="checkbox"/> <b>Fault</b> <input type="checkbox"/> Trouble <input checked="" type="checkbox"/> Quick stop by trouble <input type="checkbox"/> Warning locked <input type="checkbox"/> Warning <input type="checkbox"/> Information	
Setting: <a href="#">C02111</a> ( <input checked="" type="checkbox"/> Adjustable response)	
<b>Cause</b>	<b>Remedy</b>
Program runtime in user task is too high.	Reduce program runtime by means of: <ul style="list-style-type: none"> <li>• Omitting functions (e.g. by reducing the number of active FBs).</li> <li>• Optimisation of functions to the calculating time.</li> </ul>

## IdleTask: Overflow [0x006a0006]

Module ID (decimal)	Error ID (decimal)
106: Runtime environment for IEC 61131-3 programs	6
<b>Reaction</b> (Lenze setting in bold)	
<input type="checkbox"/> None <input type="checkbox"/> System fault <input checked="" type="checkbox"/> <b>Fault</b> <input type="checkbox"/> Trouble <input type="checkbox"/> Quick stop by trouble <input type="checkbox"/> Warning locked <input type="checkbox"/> Warning <input type="checkbox"/> Information	
<b>Cause</b>	<b>Remedy</b>
Program runtime in idle task is too high.	Reduce program runtime by means of: <ul style="list-style-type: none"> <li>• Omitting functions (e.g. by reducing the number of active FBs).</li> <li>• Optimisation of functions to the calculating time.</li> </ul>

**Runtime error [0x006a000d]**

Module ID (decimal)	Error ID (decimal)
106: Runtime environment for IEC 61131-3 programs	13
<b>Reaction</b> (Lenze setting in bold)	
<input type="checkbox"/> None <input type="checkbox"/> System fault <input checked="" type="checkbox"/> <b>Fault</b> <input type="checkbox"/> Trouble <input type="checkbox"/> Quick stop by trouble <input type="checkbox"/> Warning locked <input type="checkbox"/> Warning <input type="checkbox"/> Information	
<b>Cause</b>	<b>Remedy</b>
A runtime error has occurred in the application. The application processing has been interrupted.	Remove runtime error in the application and retransfer application to controller.

**Application has stopped [0x006a000e]**

Module ID (decimal)	Error ID (decimal)
106: Runtime environment for IEC 61131-3 programs	14
<b>Reaction</b> (Lenze setting in bold)	
<input type="checkbox"/> None <input type="checkbox"/> System fault <input type="checkbox"/> Fault <input type="checkbox"/> Trouble <input type="checkbox"/> Quick stop by trouble <input type="checkbox"/> Warning locked <input type="checkbox"/> Warning <input checked="" type="checkbox"/> <b>Information</b>	
<b>Cause</b>	<b>Remedy</b>
The application has been stopped using the device command <code>C00002="32"</code> . All user tasks are stopped.	Restart application with device command <code>C00002="31"</code> .

**Breakpoint reached [0x006a000f]**

Module ID (decimal)	Error ID (decimal)
106: Runtime environment for IEC 61131-3 programs	15
<b>Reaction</b> (Lenze setting in bold)	
<input type="checkbox"/> None <input type="checkbox"/> System fault <input type="checkbox"/> Fault <input type="checkbox"/> Trouble <input type="checkbox"/> Quick stop by trouble <input type="checkbox"/> Warning locked <input type="checkbox"/> Warning <input checked="" type="checkbox"/> <b>Information</b>	
<b>Cause</b>	<b>Remedy</b>
The application has reached a set breakpoint and the user task with the breakpoint has stopped.	Delete breakpoint and restart application.

**Faulty application parameter [0x006a0010]**

Module ID (decimal)	Error ID (decimal)
106: Runtime environment for IEC 61131-3 programs	16
<b>Reaction</b> (Lenze setting in bold)	
<input type="checkbox"/> None <input type="checkbox"/> System fault <input checked="" type="checkbox"/> <b>Fault</b> <input type="checkbox"/> Trouble <input type="checkbox"/> Quick stop by trouble <input type="checkbox"/> Warning locked <input type="checkbox"/> Warning <input type="checkbox"/> Information	
<b>Cause</b>	<b>Remedy</b>
An invalid parameter description is available.	Transmit application and parameter set to the controller again.

**Division by zero [0x006a0011]**

Module ID (decimal)	Error ID (decimal)
106: Runtime environment for IEC 61131-3 programs	17
<b>Reaction</b> (Lenze setting in bold)	
<input type="checkbox"/> None <input type="checkbox"/> System fault <input checked="" type="checkbox"/> <b>Fault</b> <input type="checkbox"/> Trouble <input type="checkbox"/> Quick stop by trouble <input type="checkbox"/> Warning locked <input type="checkbox"/> Warning <input type="checkbox"/> Information	
<b>Cause</b>	<b>Remedy</b>
An impermissible division by zero occurred in the application. The division has been intercepted and the divisor was replaced by the value "1".	Replace application.



#### Pointer access in impermissible memory area [0x006a0012]

Module ID (decimal)	Error ID (decimal)
106: Runtime environment for IEC 61131-3 programs	18
<b>Reaction</b> (Lenze setting in bold)	
<input type="checkbox"/> None <input type="checkbox"/> System fault <input checked="" type="checkbox"/> <b>Fault</b> <input type="checkbox"/> Trouble <input type="checkbox"/> Quick stop by trouble <input type="checkbox"/> Warning locked <input type="checkbox"/> Warning <input type="checkbox"/> Information	
<b>Cause</b>	<b>Remedy</b>
An invalid pointer access to a protected area occurred in the application.	Replace application.

#### Application has started [0x006a0013]

Module ID (decimal)	Error ID (decimal)
106: Runtime environment for IEC 61131-3 programs	19
<b>Reaction</b> (Lenze setting in bold)	
<input type="checkbox"/> None <input type="checkbox"/> System fault <input type="checkbox"/> Fault <input type="checkbox"/> Trouble <input type="checkbox"/> Quick stop by trouble <input type="checkbox"/> Warning locked <input type="checkbox"/> Warning <input checked="" type="checkbox"/> <b>Information</b>	
<b>Cause</b>	<b>Remedy</b>
The application in the controller has been started.	- (Information only)

#### Application has stopped [0x006a0014]

Module ID (decimal)	Error ID (decimal)
106: Runtime environment for IEC 61131-3 programs	20
<b>Reaction</b> (Lenze setting in bold)	
<input type="checkbox"/> None <input type="checkbox"/> System fault <input type="checkbox"/> Fault <input type="checkbox"/> Trouble <input type="checkbox"/> Quick stop by trouble <input type="checkbox"/> Warning locked <input type="checkbox"/> Warning <input checked="" type="checkbox"/> <b>Information</b>	
<b>Cause</b>	<b>Remedy</b>
The application in the controller has been stopped.	- (Information only)

#### PDO mapping (MXI1): Faulty configuration [0x006a0015]

Module ID (decimal)	Error ID (decimal)
106: Runtime environment for IEC 61131-3 programs	21
<b>Reaction</b> (Lenze setting in bold)	
<input type="checkbox"/> None <input type="checkbox"/> System fault <input checked="" type="checkbox"/> <b>Fault</b> <input type="checkbox"/> Trouble <input type="checkbox"/> Quick stop by trouble <input type="checkbox"/> Warning locked <input type="checkbox"/> Warning <input type="checkbox"/> Information	
<b>Cause</b>	<b>Remedy</b>
CANopen communication module in MXI1: Incorrectly configured process data mapping. <ul style="list-style-type: none"> <li>• The corresponding PDO channel is not installed, e. g. because no communication module was selected for module slot MXI1 in the Engineer project.</li> <li>• The communication module selected for module slot MXI1 in the Engineer project does not support PDO mapping.</li> <li>• The mapping information downloaded to the controller is faulty.</li> </ul>	<ul style="list-style-type: none"> <li>• Integrate suitable communication module for module slot MXI1 in the Engineer project.</li> <li>• Check the configuration of the network. Then recompile the project and transmit it to the controller.</li> </ul>

**PDO mapping (MXI2): Faulty configuration [0x006a0016]**

Module ID (decimal)	Error ID (decimal)
106: Runtime environment for IEC 61131-3 programs	22
<b>Reaction</b> (Lenze setting in bold)	
<input type="checkbox"/> None <input type="checkbox"/> System fault <input checked="" type="checkbox"/> <b>Fault</b> <input type="checkbox"/> Trouble <input type="checkbox"/> Quick stop by trouble <input type="checkbox"/> Warning locked <input type="checkbox"/> Warning <input type="checkbox"/> Information	
<b>Cause</b>	<b>Remedy</b>
CANopen communication module in MXI2: Incorrectly configured process data mapping. <ul style="list-style-type: none"> <li>• The corresponding PDO channel is not installed, e. g. because no communication module was selected for module slot MXI2 in the Engineer project.</li> <li>• The communication module selected for module slot MXI2 in the Engineer project does not support PDO mapping.</li> <li>• The mapping information downloaded to the controller is faulty.</li> </ul>	<ul style="list-style-type: none"> <li>• Integrate suitable communication module for module slot MXI2 in the Engineer project.</li> <li>• Check the configuration of the network. Then recompile the project and transmit it to the controller.</li> </ul>

**Fault in the control configuration [0x006a0017]**

Module ID (decimal)	Error ID (decimal)
106: Runtime environment for IEC 61131-3 programs	23
<b>Reaction</b> (Lenze setting in bold)	
<input type="checkbox"/> None <input checked="" type="checkbox"/> <b>System fault</b> <input type="checkbox"/> Fault <input type="checkbox"/> Trouble <input type="checkbox"/> Quick stop by trouble <input type="checkbox"/> Warning locked <input type="checkbox"/> Warning <input type="checkbox"/> Information	
<b>Cause</b>	<b>Remedy</b>
An invalid control configuration has occurred.	Load a different application.

**Retain memory of the application faulty [0x006a001a]**

Module ID (decimal)	Error ID (decimal)
106: Runtime environment for IEC 61131-3 programs	26
<b>Reaction</b> (Lenze setting in bold)	
<input type="checkbox"/> None <input type="checkbox"/> System fault <input checked="" type="checkbox"/> <b>Fault</b> <input type="checkbox"/> Trouble <input type="checkbox"/> Quick stop by trouble <input type="checkbox"/> Warning locked <input type="checkbox"/> Warning <input type="checkbox"/> Information	
<b>Cause</b>	<b>Remedy</b>
During reading or saving the retain memory of the application a fault has occurred.	Check whether the memory module suitable for the application is plugged in. Mains switching. (C00002) = 33 (reset program). Carry out project download again. <ul style="list-style-type: none"> <li>• Please contact Lenze if the problem occurs again.</li> </ul>

### Watchdog cycle is greater than task cycle [0x006a001b]

Module ID (decimal)	Error ID (decimal)
106: Runtime environment for IEC 61131-3 programs	27
<b>Reaction</b> (Lenze setting in bold)	
<input type="checkbox"/> None <input type="checkbox"/> System fault <input checked="" type="checkbox"/> <b>Fault</b> <input type="checkbox"/> Trouble <input type="checkbox"/> Quick stop by trouble <input type="checkbox"/> Warning locked <input type="checkbox"/> Warning <input checked="" type="checkbox"/> <b>Information</b>	
<b>Cause</b>	<b>Remedy</b>
An application has been downloaded <ul style="list-style-type: none"> <li>• with the highest priority task having a smaller cycle than the parameterised watchdog cycle</li> </ul> or <ul style="list-style-type: none"> <li>• with the watchdog of the highest priority task being deactivated.</li> </ul>	You can acknowledge the error if you follow the below procedure: <ol style="list-style-type: none"> <li>1. Activate watchdog</li> <li>2. Set a watchdog cycle that is smaller than or equal to the task cycle</li> <li>3. Recreate the application and download it again</li> </ol> <ul style="list-style-type: none"> <li>• <b>From software version V11.0:</b> If the device boots with an application without an activated watchdog or with a watchdog set incorrectly, only an information is entered in the logbook.</li> </ul>

### Control card: Supply voltage (24 V DC) too low [0x006f0000]

Module ID (decimal)	Error ID (decimal)
111: Monitoring of the 24V supply voltage	0
<b>Reaction</b> (Lenze setting in bold)	
<input type="checkbox"/> None <input type="checkbox"/> System fault <input type="checkbox"/> Fault <input checked="" type="checkbox"/> <b>Trouble</b> <input type="checkbox"/> Quick stop by trouble <input type="checkbox"/> Warning locked <input type="checkbox"/> Warning <input type="checkbox"/> Information	
<b>Cause</b>	<b>Remedy</b>
External 24 V supply voltage of the control card is lower than 18 V.	Check external supply voltage. <ul style="list-style-type: none"> <li>• If the external supply voltage is available and the error message does not disappear, please contact Lenze.</li> </ul>

### Read error service register [0x00720000]

Module ID (decimal)	Error ID (decimal)
114: Service register	0
<b>Reaction</b> (Lenze setting in bold)	
<input type="checkbox"/> None <input type="checkbox"/> System fault <input checked="" type="checkbox"/> <b>Fault</b> <input type="checkbox"/> Trouble <input type="checkbox"/> Quick stop by trouble <input type="checkbox"/> Warning locked <input type="checkbox"/> Warning <input type="checkbox"/> Information	
<b>Cause</b>	<b>Remedy</b>
During reading or writing the service register a fault has occurred.	Mains switching <ul style="list-style-type: none"> <li>• Please contact Lenze if the problem occurs again.</li> </ul>

### External error [0x00750000]

Module ID (decimal)	Error ID (decimal)
117: Device control	0
<b>Reaction</b> (Lenze setting in bold)	
Setting: <a href="#">C00581</a> ( <input checked="" type="checkbox"/> Adjustable response) <input checked="" type="checkbox"/> None <input type="checkbox"/> System fault <input checked="" type="checkbox"/> <b>Fault</b> <input checked="" type="checkbox"/> <b>Trouble</b> <input checked="" type="checkbox"/> Quick stop by trouble <input checked="" type="checkbox"/> Warning locked <input type="checkbox"/> Warning <input checked="" type="checkbox"/> Information	
<b>Cause</b>	<b>Remedy</b>
The drive interface has activated the error message "External error". <ul style="list-style-type: none"> <li>• The input <code>DI_bSetExternError</code> of the system block <code>LS_DriveInterface</code> has been set to TRUE.</li> </ul>	<ul style="list-style-type: none"> <li>• Check external device to be monitored.</li> <li>• Check assignment of the input <code>DI_bSetExternError</code> in the application.</li> </ul>

**Controller enabled [0x00750001]**

Module ID (decimal)	Error ID (decimal)
117: Device control	1
<b>Reaction</b> (Lenze setting in bold)	
<input type="checkbox"/> None <input type="checkbox"/> System fault <input type="checkbox"/> Fault <input type="checkbox"/> Trouble <input type="checkbox"/> Quick stop by trouble <input type="checkbox"/> Warning locked <input type="checkbox"/> Warning <input checked="" type="checkbox"/> <b>Information</b>	
<b>Cause</b>	<b>Remedy</b>
The controller is enabled and has the "Operation" state.	- (Information only)

**Controller in STO state [0x00750003]**

Module ID (decimal)	Error ID (decimal)
117: Device control	3
<b>Reaction</b> (Lenze setting in bold)	
<input type="checkbox"/> None <input type="checkbox"/> System fault <input type="checkbox"/> Fault <input type="checkbox"/> Trouble <input type="checkbox"/> Quick stop by trouble <input type="checkbox"/> Warning locked <input type="checkbox"/> Warning <input checked="" type="checkbox"/> <b>Information</b>	
<b>Cause</b>	<b>Remedy</b>
The controller has received the "Safe torque off (STO)" request by the safety module and is now in the "Safe torque off active" device state.	- (Information only)

**Controller: Pulse inhibit is active [0x00750005]**

Module ID (decimal)	Error ID (decimal)
117: Device control	5
<b>Reaction</b> (Lenze setting in bold)	
<input type="checkbox"/> None <input type="checkbox"/> System fault <input type="checkbox"/> Fault <input type="checkbox"/> Trouble <input type="checkbox"/> Quick stop by trouble <input type="checkbox"/> Warning locked <input type="checkbox"/> Warning <input checked="" type="checkbox"/> <b>Information</b>	
<b>Cause</b>	<b>Remedy</b>
The pulse inhibit is active in the controller.	- (Information only)

**PLC configuration invalid [0x00750006]**

Module ID (decimal)	Error ID (decimal)
117: Device control	6
<b>Reaction</b> (Lenze setting in bold)	
<input type="checkbox"/> None <input type="checkbox"/> System fault <input checked="" type="checkbox"/> <b>Fault</b> <input type="checkbox"/> Trouble <input type="checkbox"/> Quick stop by trouble <input type="checkbox"/> Warning locked <input type="checkbox"/> Warning <input type="checkbox"/> Information	
<b>Cause</b>	<b>Remedy</b>
An invalid control configuration has occurred.	Load a different application.

**Heatsink: Temperature > C00122 [0x00770000]**

Module ID (decimal)	Error ID (decimal)
119: Temperature monitoring	0
<b>Reaction</b> (Lenze setting in bold)	
<b>Setting:</b> <a href="#">C00582</a> ( <input checked="" type="checkbox"/> Adjustable response)	
<input checked="" type="checkbox"/> None <input type="checkbox"/> System fault <input checked="" type="checkbox"/> <b>Fault</b> <input type="checkbox"/> Trouble <input type="checkbox"/> Quick stop by trouble <input type="checkbox"/> Warning locked <input checked="" type="checkbox"/> <b>Warning</b> <input type="checkbox"/> Information	
<b>Cause</b>	<b>Remedy</b>
Heatsink temperature higher than variable temperature limit ( <a href="#">C00122</a> ). <ul style="list-style-type: none"> <li>Ambient controller temperature too high.</li> <li>Dirty fan or ventilation slots.</li> <li>Value set under C00122 is too low.</li> </ul>	<ul style="list-style-type: none"> <li>Check control cabinet temperature.</li> <li>Clean filter.</li> <li>Clean inverter.</li> <li>Set a higher value in <a href="#">C00122</a>.</li> </ul>

## Heatsink: Overtemperature [0x00770001]

Module ID (decimal)	Error ID (decimal)
119: Temperature monitoring	1
<b>Reaction</b> (Lenze setting in bold)	
<input type="checkbox"/> None <input type="checkbox"/> System fault <input checked="" type="checkbox"/> <b>Fault</b> <input type="checkbox"/> Trouble <input type="checkbox"/> Quick stop by trouble <input type="checkbox"/> Warning locked <input type="checkbox"/> Warning <input type="checkbox"/> Information	
<b>Cause</b>	<b>Remedy</b>
Heatsink temperature greater than fixed temperature limit. <ul style="list-style-type: none"> <li>• Ambient controller temperature too high.</li> <li>• Dirty fan or ventilation slots.</li> </ul> <b>Note:</b> The fixed temperature limit is dependent on the device size (DS). <ul style="list-style-type: none"> <li>• Temperature limit 90 °C: DS1 - DS7, i.e. for devices with a rated current up to 104 A</li> <li>• Temperature limit 100 °C: DS81 - DS91, i.e. for devices with a rated current from 145 A</li> </ul>	<ul style="list-style-type: none"> <li>• Check control cabinet temperature.</li> <li>• Clean filter.</li> <li>• Clean inverter.</li> </ul>

## Motor: Temperature &gt; C00121 [0x00770002]

Module ID (decimal)	Error ID (decimal)
119: Temperature monitoring	2
<b>Reaction</b> (Lenze setting in bold)	
<input checked="" type="checkbox"/> None <input type="checkbox"/> System fault <input checked="" type="checkbox"/> <b>Fault</b> <input type="checkbox"/> Trouble <input type="checkbox"/> Quick stop by trouble <input type="checkbox"/> Warning locked <input checked="" type="checkbox"/> <b>Warning</b> <input type="checkbox"/> Information	
Setting: <a href="#">C00584</a> ( <input checked="" type="checkbox"/> Adjustable response)	
<b>Cause</b>	<b>Remedy</b>
Motor temperature higher than variable temperature limit ( <a href="#">C00121</a> ). <ul style="list-style-type: none"> <li>• Motor too hot due to impermissibly high currents or frequent and too long acceleration processes.</li> <li>• No PTC connected.</li> <li>• Value set under <a href="#">C00121</a> is too low.</li> </ul>	<ul style="list-style-type: none"> <li>• Check drive dimensioning.</li> <li>• Connect PTC or switch off monitoring (<a href="#">C00584</a>="0").</li> <li>• Set a higher value in <a href="#">C00121</a>.</li> </ul>

## Motor: Overtemperature [0x00770003]

Module ID (decimal)	Error ID (decimal)
119: Temperature monitoring	3
<b>Reaction</b> (Lenze setting in bold)	
<input checked="" type="checkbox"/> None <input type="checkbox"/> System fault <input checked="" type="checkbox"/> <b>Fault</b> <input type="checkbox"/> Trouble <input type="checkbox"/> Quick stop by trouble <input type="checkbox"/> Warning locked <input checked="" type="checkbox"/> <b>Warning</b> <input type="checkbox"/> Information	
Setting: <a href="#">C00583</a> ( <input checked="" type="checkbox"/> Adjustable response)	
<b>Cause</b>	<b>Remedy</b>
Motor temperature higher than fixed temperature limit (150 °C). <ul style="list-style-type: none"> <li>• Motor too hot due to impermissibly high currents or frequent and too long acceleration processes.</li> <li>• No PTC connected.</li> </ul>	<ul style="list-style-type: none"> <li>• Check drive dimensioning.</li> <li>• Connect PTC or switch off monitoring (<a href="#">C00583</a>="0").</li> </ul>

**CPU: Temperature > C00126 [0x00770008]**

Module ID (decimal)	Error ID (decimal)
119: Temperature monitoring	8
<b>Reaction</b> (Lenze setting in bold)	
Setting: <a href="#">C00589</a> ( <input checked="" type="checkbox"/> Adjustable response)	
<input checked="" type="checkbox"/> None <input type="checkbox"/> System fault <input checked="" type="checkbox"/> Fault <input type="checkbox"/> Trouble <input type="checkbox"/> Quick stop by trouble <input type="checkbox"/> Warning locked <input checked="" type="checkbox"/> Warning <input type="checkbox"/> Information	
<b>Cause</b>	
CPU temperature higher than variable temperature limit ( <a href="#">C00126</a> ). <ul style="list-style-type: none"> <li>• Ambient controller temperature too high.</li> <li>• Dirty fan or ventilation slots.</li> <li>• Value set under C00126 is too low.</li> </ul>	<b>Remedy</b> <ul style="list-style-type: none"> <li>• Check control cabinet temperature.</li> <li>• Clean filter.</li> <li>• Clean inverter.</li> <li>• Set a higher value in <a href="#">C00126</a>.</li> </ul>

**CPU: Overtemperature [0x00770009]**

Module ID (decimal)	Error ID (decimal)
119: Temperature monitoring	9
<b>Reaction</b> (Lenze setting in bold)	
<input type="checkbox"/> None <input type="checkbox"/> System fault <input type="checkbox"/> Fault <input type="checkbox"/> Trouble <input type="checkbox"/> Quick stop by trouble <input type="checkbox"/> Warning locked <input checked="" type="checkbox"/> Warning <input type="checkbox"/> Information	
<b>Cause</b>	
CPU temperature higher than fixed limit temperature (85 °C). <ul style="list-style-type: none"> <li>• Ambient controller temperature too high.</li> <li>• Dirty fan or ventilation slots.</li> </ul>	<b>Remedy</b> <ul style="list-style-type: none"> <li>• Check control cabinet temperature.</li> <li>• Clean filter.</li> <li>• Clean inverter.</li> </ul>

**Heatsink: Thermal detector is defect [0x0077000a]**

Module ID (decimal)	Error ID (decimal)
119: Temperature monitoring	10
<b>Reaction</b> (Lenze setting in bold)	
Setting: <a href="#">C00588</a> ( <input checked="" type="checkbox"/> Adjustable response)	
<input checked="" type="checkbox"/> None <input type="checkbox"/> System fault <input checked="" type="checkbox"/> Fault <input type="checkbox"/> Trouble <input type="checkbox"/> Quick stop by trouble <input type="checkbox"/> Warning locked <input checked="" type="checkbox"/> Warning <input type="checkbox"/> Information	
<b>Cause</b>	
Encoder for heatsink temperature supplies undefined values.	<b>Remedy</b> Check control cabinet temperature, maybe it is too low.

**Inside the device: Thermal detector is defective [0x0077000b]**

Module ID (decimal)	Error ID (decimal)
119: Temperature monitoring	11
<b>Reaction</b> (Lenze setting in bold)	
Setting: <a href="#">C00588</a> ( <input checked="" type="checkbox"/> Adjustable response)	
<input checked="" type="checkbox"/> None <input type="checkbox"/> System fault <input checked="" type="checkbox"/> Fault <input type="checkbox"/> Trouble <input type="checkbox"/> Quick stop by trouble <input type="checkbox"/> Warning locked <input checked="" type="checkbox"/> Warning <input type="checkbox"/> Information	
<b>Cause</b>	
Encoder for interior temperature supplies undefined values.	<b>Remedy</b> Check control cabinet temperature, maybe it is too low.

**Motor: Thermal detector is defect [0x0077000c]**

Module ID (decimal)	Error ID (decimal)
119: Temperature monitoring	12
<b>Reaction</b> (Lenze setting in bold)	<b>Setting:</b> <a href="#">C00594</a> ( <input checked="" type="checkbox"/> Adjustable response)
<input checked="" type="checkbox"/> None <input type="checkbox"/> System fault <input checked="" type="checkbox"/> <b>Fault</b> <input type="checkbox"/> Trouble <input type="checkbox"/> Quick stop by trouble <input type="checkbox"/> Warning locked <input checked="" type="checkbox"/> Warning <input type="checkbox"/> Information	
Cause	Remedy
The signals of the connected encoder for the motor temperature detection (resolver at X7 or encoder at X8) are outside the defined operating range of the detection.	<ul style="list-style-type: none"> <li>• Check contacts of the encoder cable at the motor and controller.</li> <li>• Check selection of the motor temperature sensor in <a href="#">C01190</a> and make sure that it complies with the assembly in the motor.</li> <li>• Possibly switch off temperature sensor monitoring (<a href="#">C00594</a>="0").</li> <li>• If a PTC is in the motor, activate the monitoring of the PTC temperature in <a href="#">C00585</a> instead.</li> </ul>

**DC-bus capacitor: Thermal detector is defect [0x0077000d]**

Module ID (decimal)	Error ID (decimal)
119: Temperature monitoring	13
<b>Reaction</b> (Lenze setting in bold)	<b>Setting:</b> <a href="#">C00588</a> ( <input checked="" type="checkbox"/> Adjustable response)
<input checked="" type="checkbox"/> None <input type="checkbox"/> System fault <input checked="" type="checkbox"/> <b>Fault</b> <input type="checkbox"/> Trouble <input type="checkbox"/> Quick stop by trouble <input type="checkbox"/> Warning locked <input checked="" type="checkbox"/> Warning <input type="checkbox"/> Information	
Cause	Remedy
Encoder for capacitor temperature supplies undefined values.	Check control cabinet temperature, maybe it is too low.

**CPU: Thermal detector is defect [0x0077000e]**

Module ID (decimal)	Error ID (decimal)
119: Temperature monitoring	14
<b>Reaction</b> (Lenze setting in bold)	<b>Setting:</b> <a href="#">C00588</a> ( <input checked="" type="checkbox"/> Adjustable response)
<input checked="" type="checkbox"/> None <input type="checkbox"/> System fault <input checked="" type="checkbox"/> <b>Fault</b> <input type="checkbox"/> Trouble <input type="checkbox"/> Quick stop by trouble <input type="checkbox"/> Warning locked <input checked="" type="checkbox"/> Warning <input type="checkbox"/> Information	
Cause	Remedy
Encoder for CPU temperature supplies undefined values.	Check control cabinet temperature, maybe it is too low.

**Motor: PTC has triggered [0x0077000f]**

Module ID (decimal)	Error ID (decimal)
119: Temperature monitoring	15
<b>Reaction</b> (Lenze setting in bold)	<b>Setting:</b> <a href="#">C00585</a> ( <input checked="" type="checkbox"/> Adjustable response)
<input checked="" type="checkbox"/> <b>None</b> <input type="checkbox"/> System fault <input checked="" type="checkbox"/> <b>Fault</b> <input type="checkbox"/> Trouble <input type="checkbox"/> Quick stop by trouble <input type="checkbox"/> Warning locked <input checked="" type="checkbox"/> Warning <input type="checkbox"/> Information	
Cause	Remedy
<p>The motor temperature detected via the terminals T1/T2 is too high.</p> <ul style="list-style-type: none"> <li>• Motor is too hot due to an increased effective current that results from operation with too high/too frequent acceleration processes.</li> <li>• Motor too hot due to increased ambient conditions.</li> <li>• Motor too hot due to lacking cooling in the case of self-ventilation and continuous operation with speeds lower than the rated speed.</li> <li>• Terminals T1/T2 are not assigned.</li> <li>• Open circuit of the supply cables for terminals T1/T2.</li> </ul>	<ul style="list-style-type: none"> <li>• Check drive dimensioning.</li> <li>• Connect PTC or thermal contact to terminals T1/T2.</li> <li>• If a motor without integrated temperature monitoring is used, switch off the monitoring function (<a href="#">C00585</a>="0").</li> </ul>

## Heatsink: Fan is defect [0x00770010]

Module ID (decimal)	Error ID (decimal)
119: Temperature monitoring	16
<b>Reaction</b> (Lenze setting in bold)	
Setting: <a href="#">C00610</a> ( <input checked="" type="checkbox"/> Adjustable response)	
<input checked="" type="checkbox"/> None <input type="checkbox"/> System fault <input checked="" type="checkbox"/> <b>Fault</b> <input type="checkbox"/> Trouble <input type="checkbox"/> Quick stop by trouble <input type="checkbox"/> Warning locked <input checked="" type="checkbox"/> Warning <input type="checkbox"/> Information	
<b>Cause</b>	
Speed of heatsink fan too low, e.g. due to dirt.	<b>Remedy</b>
	Check/clean fan.

## Inside the device: Fan is defective [0x00770011]

Module ID (decimal)	Error ID (decimal)
119: Temperature monitoring	17
<b>Reaction</b> (Lenze setting in bold)	
Setting: <a href="#">C00611</a> ( <input checked="" type="checkbox"/> Adjustable response)	
<input checked="" type="checkbox"/> None <input type="checkbox"/> System fault <input checked="" type="checkbox"/> <b>Fault</b> <input type="checkbox"/> Trouble <input type="checkbox"/> Quick stop by trouble <input type="checkbox"/> Warning locked <input checked="" type="checkbox"/> Warning <input type="checkbox"/> Information	
<b>Cause</b>	
Speed of internal fan is too low, e.g. due to dirt.	<b>Remedy</b>
	Check/clean fan.

## Device utilisation Ixt &gt; C00123 [0x00780000]

Module ID (decimal)	Error ID (decimal)
120: Analog signal monitoring	0
<b>Reaction</b> (Lenze setting in bold)	
Setting: <a href="#">C00604</a> . ( <input checked="" type="checkbox"/> Adjustable response)	
<input checked="" type="checkbox"/> None <input type="checkbox"/> System fault <input checked="" type="checkbox"/> <b>Fault</b> <input type="checkbox"/> Trouble <input type="checkbox"/> Quick stop by trouble <input type="checkbox"/> Warning locked <input checked="" type="checkbox"/> <b>Warning</b> <input type="checkbox"/> Information	
<b>Cause</b>	
Frequent and too long acceleration processes with overcurrent > <a href="#">C00123</a> .	<b>Remedy</b>
	Check drive dimensioning.

## Device utilisation Ixt &gt; 100 % [0x00780001]

Module ID (decimal)	Error ID (decimal)
120: Analog signal monitoring	1
<b>Reaction</b> (Lenze setting in bold)	
<input type="checkbox"/> None <input type="checkbox"/> System fault <input checked="" type="checkbox"/> <b>Fault</b> <input type="checkbox"/> Trouble <input type="checkbox"/> Quick stop by trouble <input type="checkbox"/> Warning locked <input type="checkbox"/> Warning <input type="checkbox"/> Information	
<b>Cause</b>	
Frequent and too long acceleration processes with overcurrent.	<b>Remedy</b>
	Check drive dimensioning.

Motor load I<sup>2</sup>xt > C00127 [0x00780002]

Module ID (decimal)	Error ID (decimal)
120: Analog signal monitoring	2
<b>Reaction</b> (Lenze setting in bold)	
Setting: <a href="#">C00606</a> . ( <input checked="" type="checkbox"/> Adjustable response)	
<input checked="" type="checkbox"/> None <input type="checkbox"/> System fault <input checked="" type="checkbox"/> <b>Fault</b> <input type="checkbox"/> Trouble <input type="checkbox"/> Quick stop by trouble <input type="checkbox"/> Warning locked <input checked="" type="checkbox"/> <b>Warning</b> <input type="checkbox"/> Information	
<b>Cause</b>	
Motor is thermally overloaded, e.g. due to: <ul style="list-style-type: none"> <li>• impermissible continuous current</li> <li>• frequent or too long acceleration processes</li> </ul>	<b>Remedy</b>
	<ul style="list-style-type: none"> <li>• Check drive dimensioning.</li> <li>• Check setting in <a href="#">C00127</a>.</li> </ul>



**Motor load I<sup>3</sup>t > C00120 [0x00780003]**

Module ID (decimal)	Error ID (decimal)
120: Analog signal monitoring	3
<b>Reaction</b> (Lenze setting in bold)	
<input type="checkbox"/> None <input type="checkbox"/> System fault <input checked="" type="checkbox"/> <b>Fault</b> <input type="checkbox"/> Trouble <input type="checkbox"/> Quick stop by trouble <input type="checkbox"/> Warning locked <input type="checkbox"/> Warning <input type="checkbox"/> Information	
<b>Cause</b>	<b>Remedy</b>
Motor is thermally overloaded, e.g. due to: <ul style="list-style-type: none"> <li>• impermissible continuous current</li> <li>• frequent or too long acceleration processes</li> </ul>	<ul style="list-style-type: none"> <li>• Check drive dimensioning.</li> <li>• Check setting in <a href="#">C00120</a>.</li> </ul>

**Control card is defect (UB24) [0x00780004]**

Module ID (decimal)	Error ID (decimal)
120: Analog signal monitoring	4
<b>Reaction</b> (Lenze setting in bold)	
<input type="checkbox"/> None <input checked="" type="checkbox"/> <b>System fault</b> <input type="checkbox"/> Fault <input type="checkbox"/> Trouble <input type="checkbox"/> Quick stop by trouble <input type="checkbox"/> Warning locked <input type="checkbox"/> Warning <input type="checkbox"/> Information	
<b>Cause</b>	<b>Remedy</b>
Device error	Please contact Lenze.

**Control card is defect (VCC15) [0x00780005]**

Module ID (decimal)	Error ID (decimal)
120: Analog signal monitoring	5
<b>Reaction</b> (Lenze setting in bold)	
<input type="checkbox"/> None <input checked="" type="checkbox"/> <b>System fault</b> <input type="checkbox"/> Fault <input type="checkbox"/> Trouble <input type="checkbox"/> Quick stop by trouble <input type="checkbox"/> Warning locked <input type="checkbox"/> Warning <input type="checkbox"/> Information	
<b>Cause</b>	<b>Remedy</b>
Device error	Please contact Lenze.

**Control card is defect (UB8) [0x00780006]**

Module ID (decimal)	Error ID (decimal)
120: Analog signal monitoring	6
<b>Reaction</b> (Lenze setting in bold)	
<input type="checkbox"/> None <input checked="" type="checkbox"/> <b>System fault</b> <input type="checkbox"/> Fault <input type="checkbox"/> Trouble <input type="checkbox"/> Quick stop by trouble <input type="checkbox"/> Warning locked <input type="checkbox"/> Warning <input type="checkbox"/> Information	
<b>Cause</b>	<b>Remedy</b>
Device error	Please contact Lenze.

**Control card is defect (VCC15 neg.) [0x00780007]**

Module ID (decimal)	Error ID (decimal)
120: Analog signal monitoring	7
<b>Reaction</b> (Lenze setting in bold)	
<input type="checkbox"/> None <input checked="" type="checkbox"/> <b>System fault</b> <input type="checkbox"/> Fault <input type="checkbox"/> Trouble <input type="checkbox"/> Quick stop by trouble <input type="checkbox"/> Warning locked <input type="checkbox"/> Warning <input type="checkbox"/> Information	
<b>Cause</b>	<b>Remedy</b>
Device error	Please contact Lenze.

**Control card is defect (UB18 neg.) [0x00780008]**

Module ID (decimal)	Error ID (decimal)
120: Analog signal monitoring	8
Reaction (Lenze setting in bold)	
<input type="checkbox"/> None <input checked="" type="checkbox"/> <b>System fault</b> <input type="checkbox"/> Fault <input type="checkbox"/> Trouble <input type="checkbox"/> Quick stop by trouble <input type="checkbox"/> Warning locked <input type="checkbox"/> Warning <input type="checkbox"/> Information	
Cause	Remedy
Device error	Please contact Lenze.

**Control card is defect (VCC5) [0x00780009]**

Module ID (decimal)	Error ID (decimal)
120: Analog signal monitoring	9
Reaction (Lenze setting in bold)	
<input type="checkbox"/> None <input checked="" type="checkbox"/> <b>System fault</b> <input type="checkbox"/> Fault <input type="checkbox"/> Trouble <input type="checkbox"/> Quick stop by trouble <input type="checkbox"/> Warning locked <input type="checkbox"/> Warning <input type="checkbox"/> Information	
Cause	Remedy
Device error	Please contact Lenze.

**Electronic nameplate: Data are incompatible [0x0078000a]**

Module ID (decimal)	Error ID (decimal)
120: Analog signal monitoring	10
Reaction (Lenze setting in bold)	
<input type="checkbox"/> None <input type="checkbox"/> System fault <input type="checkbox"/> Fault <input type="checkbox"/> Trouble <input type="checkbox"/> Quick stop by trouble <input type="checkbox"/> Warning locked <input type="checkbox"/> Warning <input checked="" type="checkbox"/> <b>Information</b>	
Cause	Remedy
The connected motor with feedback is not supported by the controller firmware.	Check drive dimensioning.

**Device command transferred incorrectly [0x00790000]**

Module ID (decimal)	Error ID (decimal)
121: Motor data interface	0
Reaction (Lenze setting in bold)	
<input type="checkbox"/> None <input checked="" type="checkbox"/> <b>System fault</b> <input type="checkbox"/> Fault <input type="checkbox"/> Trouble <input type="checkbox"/> Quick stop by trouble <input type="checkbox"/> Warning locked <input type="checkbox"/> Warning <input type="checkbox"/> Information	
Cause	Remedy
Internal error	If the error occurs frequently, please contact Lenze.

**Time error - controller interface [0x00790001]**

Module ID (decimal)	Error ID (decimal)
121: Motor data interface	1
Reaction (Lenze setting in bold)	
<input type="checkbox"/> None <input checked="" type="checkbox"/> <b>System fault</b> <input type="checkbox"/> Fault <input type="checkbox"/> Trouble <input type="checkbox"/> Quick stop by trouble <input type="checkbox"/> Warning locked <input type="checkbox"/> Warning <input type="checkbox"/> Information	
Cause	Remedy
Internal error	If the error occurs frequently, please contact Lenze.

**Violation of time slice [0x00790002]**

Module ID (decimal)	Error ID (decimal)
121: Motor data interface	2
<b>Reaction</b> (Lenze setting in bold)	
<input type="checkbox"/> None <input type="checkbox"/> System fault <input checked="" type="checkbox"/> <b>Fault</b> <input type="checkbox"/> Trouble <input type="checkbox"/> Quick stop by trouble <input type="checkbox"/> Warning locked <input type="checkbox"/> Warning <input type="checkbox"/> Information	
<b>Cause</b>	<b>Remedy</b>
Internal error	If the error occurs frequently, please contact Lenze.

**Motor: Calculated motor impedance unrealistic [0x007b0001]**

Module ID (decimal)	Error ID (decimal)
123: Motor control	1
<b>Reaction</b> (Lenze setting in bold)	
<input type="checkbox"/> None <input type="checkbox"/> System fault <input type="checkbox"/> Fault <input type="checkbox"/> Trouble <input type="checkbox"/> Quick stop by trouble <input type="checkbox"/> Warning locked <input type="checkbox"/> Warning <input checked="" type="checkbox"/> <b>Information</b>	
<b>Cause</b>	<b>Remedy</b>
Faulty motor parameterisation.	Check motor parameters.

**Motor: Calculated mutual inductance unrealistic [0x007b0002]**

Module ID (decimal)	Error ID (decimal)
123: Motor control	2
<b>Reaction</b> (Lenze setting in bold)	
<input type="checkbox"/> None <input type="checkbox"/> System fault <input type="checkbox"/> Fault <input type="checkbox"/> Trouble <input type="checkbox"/> Quick stop by trouble <input type="checkbox"/> Warning locked <input type="checkbox"/> Warning <input checked="" type="checkbox"/> <b>Information</b>	
<b>Cause</b>	<b>Remedy</b>
Faulty motor parameterisation.	Check motor parameters.

**Motor data are inconsistent [0x007b0003]**

Module ID (decimal)	Error ID (decimal)
123: Motor control	3
<b>Reaction</b> (Lenze setting in bold)	
<input type="checkbox"/> None <input type="checkbox"/> System fault <input type="checkbox"/> Fault <input type="checkbox"/> Trouble <input type="checkbox"/> Quick stop by trouble <input type="checkbox"/> Warning locked <input type="checkbox"/> Warning <input checked="" type="checkbox"/> <b>Information</b>	
<b>Cause</b>	<b>Remedy</b>
Faulty motor parameterisation.	Check motor parameters.

**Motor: Phase resistance too high [0x007b0004]**

Module ID (decimal)	Error ID (decimal)
123: Motor control	4
<b>Reaction</b> (Lenze setting in bold)	
<input type="checkbox"/> None <input type="checkbox"/> System fault <input type="checkbox"/> Fault <input type="checkbox"/> Trouble <input type="checkbox"/> Quick stop by trouble <input type="checkbox"/> Warning locked <input type="checkbox"/> Warning <input checked="" type="checkbox"/> <b>Information</b>	
<b>Cause</b>	<b>Remedy</b>
Faulty motor parameterisation.	Check motor parameters.

**Motor: Device current too low for rated magnetisation [0x007b0006]**

Module ID (decimal)	Error ID (decimal)
123: Motor control	6
<b>Reaction</b> (Lenze setting in bold)	
<input type="checkbox"/> None <input type="checkbox"/> System fault <input type="checkbox"/> Fault <input type="checkbox"/> Trouble <input type="checkbox"/> Quick stop by trouble <input type="checkbox"/> Warning locked <input type="checkbox"/> Warning <input checked="" type="checkbox"/> <b>Information</b>	
<b>Cause</b>	<b>Remedy</b>
Controller current is too low for rated magnetisation, i.e. the controller cannot energise the motor sufficiently.	Check drive dimensioning.

**Motor: Rated current < rated magnetising current [0x007b0007]**

Module ID (decimal)	Error ID (decimal)
123: Motor control	7
<b>Reaction</b> (Lenze setting in bold)	
<input type="checkbox"/> None <input type="checkbox"/> System fault <input type="checkbox"/> Fault <input type="checkbox"/> Trouble <input type="checkbox"/> Quick stop by trouble <input type="checkbox"/> Warning locked <input type="checkbox"/> Warning <input checked="" type="checkbox"/> <b>Information</b>	
<b>Cause</b>	<b>Remedy</b>
Faulty motor parameterisation.	Check motor parameters and setting of <a href="#">C00022</a> .

**Motor: Calculated rotor resistance unrealistic [0x007b0009]**

Module ID (decimal)	Error ID (decimal)
123: Motor control	9
<b>Reaction</b> (Lenze setting in bold)	
<input type="checkbox"/> None <input type="checkbox"/> System fault <input type="checkbox"/> Fault <input type="checkbox"/> Trouble <input type="checkbox"/> Quick stop by trouble <input type="checkbox"/> Warning locked <input type="checkbox"/> Warning <input checked="" type="checkbox"/> <b>Information</b>	
<b>Cause</b>	<b>Remedy</b>
Faulty motor parameterisation.	Check motor parameters.

**Motor: Calculated mutual inductance unrealistic [0x007b000a]**

Module ID (decimal)	Error ID (decimal)
123: Motor control	10
<b>Reaction</b> (Lenze setting in bold)	
<input type="checkbox"/> None <input type="checkbox"/> System fault <input type="checkbox"/> Fault <input type="checkbox"/> Trouble <input type="checkbox"/> Quick stop by trouble <input type="checkbox"/> Warning locked <input type="checkbox"/> Warning <input checked="" type="checkbox"/> <b>Information</b>	
<b>Cause</b>	<b>Remedy</b>
Faulty motor parameterisation.	Check motor parameters.

**Motor: Calculated e. m. f. factor unrealistic [0x007b000b]**

Module ID (decimal)	Error ID (decimal)
123: Motor control	11
<b>Reaction</b> (Lenze setting in bold)	
<input type="checkbox"/> None <input type="checkbox"/> System fault <input type="checkbox"/> Fault <input type="checkbox"/> Trouble <input type="checkbox"/> Quick stop by trouble <input type="checkbox"/> Warning locked <input type="checkbox"/> Warning <input checked="" type="checkbox"/> <b>Information</b>	
<b>Cause</b>	<b>Remedy</b>
Faulty motor parameterisation.	Check motor parameters.

**Motor: Calculated rotor time constant unrealistic [0x007b000c]**

Module ID (decimal)	Error ID (decimal)
123: Motor control	12
<b>Reaction</b> (Lenze setting in bold)	
<input type="checkbox"/> None <input type="checkbox"/> System fault <input type="checkbox"/> Fault <input type="checkbox"/> Trouble <input type="checkbox"/> Quick stop by trouble <input type="checkbox"/> Warning locked <input type="checkbox"/> Warning <input checked="" type="checkbox"/> <b>Information</b>	
<b>Cause</b>	<b>Remedy</b>
Faulty motor parameterisation.	Check motor parameters.

**Motor: Calculated flux factor unrealistic [0x007b000d]**

Module ID (decimal)	Error ID (decimal)
123: Motor control	13
<b>Reaction</b> (Lenze setting in bold)	
<input type="checkbox"/> None <input type="checkbox"/> System fault <input type="checkbox"/> Fault <input type="checkbox"/> Trouble <input type="checkbox"/> Quick stop by trouble <input type="checkbox"/> Warning locked <input type="checkbox"/> Warning <input checked="" type="checkbox"/> <b>Information</b>	
<b>Cause</b>	<b>Remedy</b>
Faulty motor parameterisation.	Check motor parameters.

**DC bus overvoltage [0x007b000e]**

Module ID (decimal)	Error ID (decimal)
123: Motor control	14
<b>Reaction</b> (Lenze setting in bold)	
Setting: <a href="#">C00600</a> . <input checked="" type="checkbox"/> Adjustable response <input type="checkbox"/> None <input type="checkbox"/> System fault <input checked="" type="checkbox"/> Fault <input checked="" type="checkbox"/> <b>Trouble</b> <input type="checkbox"/> Quick stop by trouble <input type="checkbox"/> Warning locked <input type="checkbox"/> Warning <input type="checkbox"/> Information	
<b>Cause</b>	<b>Remedy</b>
Due to a too high braking energy, the DC-bus voltage exceeds the overvoltage threshold which results from the mains voltage setting in <a href="#">C00173</a> .	<ul style="list-style-type: none"> <li>• Use brake resistor or regenerative module.</li> <li>• Check setting in <a href="#">C00173</a>.</li> </ul>

**DC bus undervoltage [0x007b000f]**

Module ID (decimal)	Error ID (decimal)
123: Motor control	15
<b>Reaction</b> (Lenze setting in bold)	
<input type="checkbox"/> None <input type="checkbox"/> System fault <input type="checkbox"/> Fault <input checked="" type="checkbox"/> <b>Trouble</b> <input type="checkbox"/> Quick stop by trouble <input type="checkbox"/> Warning locked <input type="checkbox"/> Warning <input type="checkbox"/> Information	
<b>Cause</b>	<b>Remedy</b>
DC bus voltage is lower than the undervoltage threshold resulting from the mains setting under <a href="#">C00173</a> .	<ul style="list-style-type: none"> <li>• Check mains voltage.</li> <li>• Check setting in <a href="#">C00173</a>.</li> </ul>

**Overcurrent detected [0x007b0010]**

Module ID (decimal)	Error ID (decimal)
123: Motor control	16
<b>Reaction</b> (Lenze setting in bold)	
<input type="checkbox"/> None <input type="checkbox"/> System fault <input checked="" type="checkbox"/> <b>Fault</b> <input type="checkbox"/> Trouble <input type="checkbox"/> Quick stop by trouble <input type="checkbox"/> Warning locked <input type="checkbox"/> Warning <input type="checkbox"/> Information	
<b>Cause</b>	<b>Remedy</b>
<ul style="list-style-type: none"> <li>• Short circuit/earth fault in motor cable.</li> <li>• Excessive capacitive charging current in the motor cable.</li> </ul>	<ul style="list-style-type: none"> <li>• Check motor cable.</li> <li>• Use shorter or lower-capacitance motor cable.</li> </ul>

**Earth fault detected [0x007b0011]**

Module ID (decimal)	Error ID (decimal)
123: Motor control	17
<b>Reaction</b> (Lenze setting in bold)	
<input type="checkbox"/> None <input type="checkbox"/> System fault <input checked="" type="checkbox"/> <b>Fault</b> <input type="checkbox"/> Trouble <input type="checkbox"/> Quick stop by trouble <input type="checkbox"/> Warning locked <input type="checkbox"/> Warning <input type="checkbox"/> Information	
<b>Cause</b>	<b>Remedy</b>
<ul style="list-style-type: none"> <li>• Earth fault in motor cable.</li> <li>• Excessive capacitive charging current in the motor cable.</li> </ul>	<ul style="list-style-type: none"> <li>• Check motor cable.</li> <li>• Use shorter or lower-capacitance motor cable.</li> </ul>

**Actual speed value outside the tolerance (C00576) [0x007b0012]**

Module ID (decimal)	Error ID (decimal)
123: Motor control	18
<b>Reaction</b> (Lenze setting in bold)	
<b>Setting:</b> <a href="#">C00579</a> ( <input checked="" type="checkbox"/> Adjustable response)	
<input checked="" type="checkbox"/> <b>None</b> <input type="checkbox"/> System fault <input checked="" type="checkbox"/> <b>Fault</b> <input checked="" type="checkbox"/> <b>Trouble</b> <input checked="" type="checkbox"/> <b>Quick stop by trouble</b> <input checked="" type="checkbox"/> <b>Warning locked</b> <input checked="" type="checkbox"/> <b>Warning</b> <input type="checkbox"/> Information	
<b>Cause</b>	<b>Remedy</b>
Difference between actual and setpoint speed is too big.	<ul style="list-style-type: none"> <li>• Increase speed tolerance margin under <a href="#">C00576</a>.</li> <li>• Check drive dimensioning.</li> </ul>

**Motor control: Task overflow [0x007b0013]**

Module ID (decimal)	Error ID (decimal)
123: Motor control	19
<b>Reaction</b> (Lenze setting in bold)	
<input type="checkbox"/> None <input checked="" type="checkbox"/> <b>System fault</b> <input type="checkbox"/> Fault <input type="checkbox"/> Trouble <input type="checkbox"/> Quick stop by trouble <input type="checkbox"/> Warning locked <input type="checkbox"/> Warning <input type="checkbox"/> Information	
<b>Cause</b>	<b>Remedy</b>
Internal error (motor control).	Please contact Lenze.

**Internal communication error (host MCTRL) [0x007b0014]**

Module ID (decimal)	Error ID (decimal)
123: Motor control	20
<b>Reaction</b> (Lenze setting in bold)	
<input type="checkbox"/> None <input checked="" type="checkbox"/> <b>System fault</b> <input type="checkbox"/> Fault <input type="checkbox"/> Trouble <input type="checkbox"/> Quick stop by trouble <input type="checkbox"/> Warning locked <input type="checkbox"/> Warning <input type="checkbox"/> Information	
<b>Cause</b>	<b>Remedy</b>
Internal error (motor control).	Please contact Lenze.

**Motor data are inconsistent [0x007b0017]**

Module ID (decimal)	Error ID (decimal)
123: Motor control	23
<b>Reaction</b> (Lenze setting in bold)	
<input type="checkbox"/> None <input type="checkbox"/> System fault <input type="checkbox"/> Fault <input type="checkbox"/> Trouble <input type="checkbox"/> Quick stop by trouble <input type="checkbox"/> Warning locked <input type="checkbox"/> Warning <input checked="" type="checkbox"/> <b>Information</b>	
<b>Cause</b>	<b>Remedy</b>
Faulty motor parameterisation.	Check motor parameters.

**Resolver: Open circuit [0x007b0018]**

Module ID (decimal)	Error ID (decimal)
123: Motor control	24
<b>Reaction</b> (Lenze setting in bold)	
<input type="checkbox"/> None <input type="checkbox"/> System fault <input checked="" type="checkbox"/> <b>Fault</b> <input checked="" type="checkbox"/> Trouble <input checked="" type="checkbox"/> Quick stop by trouble <input checked="" type="checkbox"/> Warning locked <input checked="" type="checkbox"/> Warning <input type="checkbox"/> Information	
<b>Cause</b>	<b>Remedy</b>
<ul style="list-style-type: none"> <li>• Resolver cable interrupted.</li> <li>• Resolver defective.</li> </ul>	<ul style="list-style-type: none"> <li>• Check resolver cable.</li> <li>• Check resolver.</li> <li>• Switch off the monitoring function (<a href="#">C00586</a>="0") if no resolver is used.</li> </ul>

**Motor: Calculated leakage inductance unrealistic [0x007b0019]**

Module ID (decimal)	Error ID (decimal)
123: Motor control	25
<b>Reaction</b> (Lenze setting in bold)	
<input type="checkbox"/> None <input type="checkbox"/> System fault <input type="checkbox"/> Fault <input type="checkbox"/> Trouble <input type="checkbox"/> Quick stop by trouble <input type="checkbox"/> Warning locked <input type="checkbox"/> Warning <input checked="" type="checkbox"/> <b>Information</b>	
<b>Cause</b>	<b>Remedy</b>
Faulty motor parameterisation.	Check motor parameters.

**Absolute value encoder: Communication error [0x007b001a]**

Module ID (decimal)	Error ID (decimal)
123: Motor control	26
<b>Reaction</b> (Lenze setting in bold)	
<input type="checkbox"/> None <input type="checkbox"/> System fault <input checked="" type="checkbox"/> <b>Fault</b> <input type="checkbox"/> Trouble <input type="checkbox"/> Quick stop by trouble <input type="checkbox"/> Warning locked <input type="checkbox"/> Warning <input type="checkbox"/> Information	
<b>Cause</b>	<b>Remedy</b>
Absolute value encoder does not send any data or a digital readout has been activated while the machine is coasting down.	<ul style="list-style-type: none"> <li>• Check supply cable.</li> <li>• Check encoder.</li> <li>• Check voltage supply (<a href="#">C00421</a>).</li> <li>• For Hiperface absolute value encoders: Check the initialisation time (<a href="#">C00412</a>).</li> </ul>

**Encoder: Open circuit [0x007b001b]**

Module ID (decimal)	Error ID (decimal)
123: Motor control	27
<b>Reaction</b> (Lenze setting in bold)	
Setting: <a href="#">C00580</a> ( <input checked="" type="checkbox"/> Adjustable response)	
<input checked="" type="checkbox"/> None <input type="checkbox"/> System fault <input checked="" type="checkbox"/> <b>Fault</b> <input checked="" type="checkbox"/> Trouble <input checked="" type="checkbox"/> Quick stop by trouble <input checked="" type="checkbox"/> Warning locked <input checked="" type="checkbox"/> Warning <input type="checkbox"/> Information	
<b>Cause</b>	
<ul style="list-style-type: none"> <li>Encoder cable interrupted.</li> <li>Encoder defective.</li> <li>Faulty parameter setting of the encoder.</li> <li>Interruption of the light path of laser measuring systems.</li> <li>Insufficient reflection of the light of laser measuring systems.</li> </ul> <p><b>Note:</b> The encoder open-circuit monitoring for incremental encoders (<a href="#">C00422</a> = "0: Incremental encoder (TTL signal)") requires a signal amplitude &gt; 3.5 V! If the signal amplitude is lower than 3.0 V, the error response parameterised in <a href="#">C00580</a> is triggered.</p>	<b>Remedy</b>
	<ul style="list-style-type: none"> <li>Check encoder cable.</li> <li>Check encoder.</li> <li>Check parameter setting (<a href="#">C00422</a>).</li> <li>Switch off the monitoring function (<a href="#">C00580</a>="0") if no encoder is used.</li> <li>Correct the light path (for laser measuring systems).</li> <li>Improve the reflection (for laser measuring systems).</li> </ul>

**Brake transistor: Ixt overload [0x007b001c]**

Module ID (decimal)	Error ID (decimal)
123: Motor control	28
<b>Reaction</b> (Lenze setting in bold)	
Setting: <a href="#">C00573</a> ( <input checked="" type="checkbox"/> Adjustable response)	
<input checked="" type="checkbox"/> <b>None</b> <input type="checkbox"/> System fault <input checked="" type="checkbox"/> Fault <input checked="" type="checkbox"/> Trouble <input checked="" type="checkbox"/> Quick stop by trouble <input checked="" type="checkbox"/> Warning locked <input checked="" type="checkbox"/> Warning <input type="checkbox"/> Information	
<b>Cause</b>	
Too frequent and too long braking processes.	<b>Remedy</b>
	Check drive dimensioning.

**Brake resistor: I<sup>2</sup>xt overload [0x007b001d]**

Module ID (decimal)	Error ID (decimal)
123: Motor control	29
<b>Reaction</b> (Lenze setting in bold)	
<input type="checkbox"/> None <input type="checkbox"/> System fault <input type="checkbox"/> Fault <input type="checkbox"/> Trouble <input type="checkbox"/> Quick stop by trouble <input type="checkbox"/> Warning locked <input type="checkbox"/> Warning <input checked="" type="checkbox"/> <b>Information</b>	
<b>Cause</b>	
Too frequent and too long braking processes.	<b>Remedy</b>
	<ul style="list-style-type: none"> <li>Check drive dimensioning.</li> <li>Check parameter setting (<a href="#">C00129</a>, <a href="#">C00130</a>, <a href="#">C00131</a>).</li> </ul>

**Motor: Actual current value > C00620 [0x007b001e]**

Module ID (decimal)	Error ID (decimal)
123: Motor control	30
<b>Reaction</b> (Lenze setting in bold)	
Setting: <a href="#">C00619</a> ( <input checked="" type="checkbox"/> Adjustable response)	
<input checked="" type="checkbox"/> None <input type="checkbox"/> System fault <input checked="" type="checkbox"/> <b>Fault</b> <input checked="" type="checkbox"/> Trouble <input checked="" type="checkbox"/> Quick stop by trouble <input checked="" type="checkbox"/> Warning locked <input checked="" type="checkbox"/> Warning <input type="checkbox"/> Information	
<b>Cause</b>	
The instantaneous value of the motor current has exceeded the value set in <a href="#">C00620</a> .	<b>Remedy</b>
	<ul style="list-style-type: none"> <li>Set a higher value in <a href="#">C00620</a>.</li> <li>Reduce maximum current (<a href="#">C00022</a>).</li> <li>Change response (<a href="#">C00619</a>).</li> </ul>



**Resolver: Calculated acceleration unrealistic [0x007b001f]**

Module ID (decimal)	Error ID (decimal)
123: Motor control	31
<b>Reaction</b> (Lenze setting in bold)	
<input type="checkbox"/> None <input type="checkbox"/> System fault <input type="checkbox"/> Fault <input type="checkbox"/> Trouble <input type="checkbox"/> Quick stop by trouble <input type="checkbox"/> Warning locked <input type="checkbox"/> Warning <input checked="" type="checkbox"/> <b>Information</b>	
<b>Cause</b>	<b>Remedy</b>
Resolver evaluation faulty (implausible acceleration at the resolver).	Check structure.

**Motor: Actual speed value > C00596 [0x007b0020]**

Module ID (decimal)	Error ID (decimal)
123: Motor control	32
<b>Reaction</b> (Lenze setting in bold)	
Setting: <a href="#">C00607</a> ( <input checked="" type="checkbox"/> Adjustable response)	
<input checked="" type="checkbox"/> None <input type="checkbox"/> System fault <input checked="" type="checkbox"/> <b>Fault</b> <input checked="" type="checkbox"/> Trouble <input checked="" type="checkbox"/> Quick stop by trouble <input checked="" type="checkbox"/> Warning locked <input checked="" type="checkbox"/> Warning <input type="checkbox"/> Information	
<b>Cause</b>	<b>Remedy</b>
Threshold for speed monitoring set in <a href="#">C00596</a> has been exceeded.	Check drive dimensioning.

**Brake transistor: Overcurrent [0x007b0021]**

Module ID (decimal)	Error ID (decimal)
123: Motor control	33
<b>Reaction</b> (Lenze setting in bold)	
<input type="checkbox"/> None <input type="checkbox"/> System fault <input checked="" type="checkbox"/> <b>Fault</b> <input type="checkbox"/> Trouble <input type="checkbox"/> Quick stop by trouble <input type="checkbox"/> Warning locked <input type="checkbox"/> Warning <input type="checkbox"/> Information	
<b>Cause</b>	<b>Remedy</b>
Brake chopper short circuit/earth fault detected.	Check brake chopper cable and brake resistor.

**Position encoder: Module selected in C00490 not available [0x007b0023]**

Module ID (decimal)	Error ID (decimal)
123: Motor control	35
<b>Reaction</b> (Lenze setting in bold)	
<input type="checkbox"/> None <input type="checkbox"/> System fault <input checked="" type="checkbox"/> <b>Fault</b> <input type="checkbox"/> Trouble <input type="checkbox"/> Quick stop by trouble <input type="checkbox"/> Warning locked <input type="checkbox"/> Warning <input type="checkbox"/> Information	
<b>Cause</b>	<b>Remedy</b>
The position encode selected under <a href="#">C00490</a> has not been recognised.	<ul style="list-style-type: none"> <li>• Check position encoder.</li> <li>• Check parameter setting (<a href="#">C00490</a>).</li> </ul>

**Motor encoder: Module selected in C00495 not available [0x007b0024]**

Module ID (decimal)	Error ID (decimal)
123: Motor control	36
<b>Reaction</b> (Lenze setting in bold)	
<input type="checkbox"/> None <input type="checkbox"/> System fault <input checked="" type="checkbox"/> <b>Fault</b> <input type="checkbox"/> Trouble <input type="checkbox"/> Quick stop by trouble <input type="checkbox"/> Warning locked <input type="checkbox"/> Warning <input type="checkbox"/> Information	
<b>Cause</b>	<b>Remedy</b>
The motor encoder selected under <a href="#">C00495</a> has not been recognised.	<ul style="list-style-type: none"> <li>• Check motor encoder.</li> <li>• Check parameter setting (<a href="#">C00495</a>).</li> </ul>

**Motor temperature: Module selected in C01193 not available [0x007b0025]**

Module ID (decimal)	Error ID (decimal)
123: Motor control	37
<b>Reaction</b> (Lenze setting in bold)	
<input type="checkbox"/> None <input type="checkbox"/> System fault <input checked="" type="checkbox"/> <b>Fault</b> <input type="checkbox"/> Trouble <input type="checkbox"/> Quick stop by trouble <input type="checkbox"/> Warning locked <input type="checkbox"/> Warning <input type="checkbox"/> Information	
<b>Cause</b>	
The module for temperature feedback selected in <a href="#">C01193</a> has not been recognised.	<ul style="list-style-type: none"> <li>• Check feedback module.</li> <li>• Check parameter setting (<a href="#">C01193</a>).</li> </ul>

**EnDat encoder: Lamp error [0x007b0026]**

Module ID (decimal)	Error ID (decimal)
123: Motor control	38
<b>Reaction</b> (Lenze setting in bold)	
<input type="checkbox"/> None <input type="checkbox"/> System fault <input type="checkbox"/> Fault <input type="checkbox"/> Trouble <input type="checkbox"/> Quick stop by trouble <input type="checkbox"/> Warning locked <input type="checkbox"/> Warning <input checked="" type="checkbox"/> <b>Information</b>	
<b>Cause</b>	
EnDat encoder defective.	Check EnDat encoder.

**EnDat encoder: Signal error [0x007b0027]**

Module ID (decimal)	Error ID (decimal)
123: Motor control	39
<b>Reaction</b> (Lenze setting in bold)	
<input type="checkbox"/> None <input type="checkbox"/> System fault <input type="checkbox"/> Fault <input type="checkbox"/> Trouble <input type="checkbox"/> Quick stop by trouble <input type="checkbox"/> Warning locked <input type="checkbox"/> Warning <input checked="" type="checkbox"/> <b>Information</b>	
<b>Cause</b>	
EnDat encoder defective.	Check EnDat encoder.

**EnDat encoder: Position error [0x007b0028]**

Module ID (decimal)	Error ID (decimal)
123: Motor control	40
<b>Reaction</b> (Lenze setting in bold)	
<input type="checkbox"/> None <input type="checkbox"/> System fault <input type="checkbox"/> Fault <input type="checkbox"/> Trouble <input type="checkbox"/> Quick stop by trouble <input type="checkbox"/> Warning locked <input type="checkbox"/> Warning <input checked="" type="checkbox"/> <b>Information</b>	
<b>Cause</b>	
EnDat encoder defective.	Check EnDat encoder.

**EnDat encoder: Overvoltage [0x007b0029]**

Module ID (decimal)	Error ID (decimal)
123: Motor control	41
<b>Reaction</b> (Lenze setting in bold)	
<input type="checkbox"/> None <input type="checkbox"/> System fault <input type="checkbox"/> Fault <input type="checkbox"/> Trouble <input type="checkbox"/> Quick stop by trouble <input type="checkbox"/> Warning locked <input type="checkbox"/> Warning <input checked="" type="checkbox"/> <b>Information</b>	
<b>Cause</b>	
EnDat encoder defective.	Check EnDat encoder.

**EnDat encoder: Undervoltage [0x007b002a]**

Module ID (decimal)	Error ID (decimal)
123: Motor control	42
<b>Reaction</b> (Lenze setting in bold)	
<input type="checkbox"/> None <input type="checkbox"/> System fault <input type="checkbox"/> Fault <input type="checkbox"/> Trouble <input type="checkbox"/> Quick stop by trouble <input type="checkbox"/> Warning locked <input type="checkbox"/> Warning <input checked="" type="checkbox"/> <b>Information</b>	
<b>Cause</b>	<b>Remedy</b>
EnDat encoder defective.	Check EnDat encoder.

**EnDat encoder: Overcurrent [0x007b002b]**

Module ID (decimal)	Error ID (decimal)
123: Motor control	43
<b>Reaction</b> (Lenze setting in bold)	
<input type="checkbox"/> None <input type="checkbox"/> System fault <input type="checkbox"/> Fault <input type="checkbox"/> Trouble <input type="checkbox"/> Quick stop by trouble <input type="checkbox"/> Warning locked <input type="checkbox"/> Warning <input checked="" type="checkbox"/> <b>Information</b>	
<b>Cause</b>	<b>Remedy</b>
EnDat encoder defective.	Check EnDat encoder.

**EnDat encoder: Battery empty [0x007b002c]**

Module ID (decimal)	Error ID (decimal)
123: Motor control	44
<b>Reaction</b> (Lenze setting in bold)	
<input type="checkbox"/> None <input type="checkbox"/> System fault <input type="checkbox"/> Fault <input type="checkbox"/> Trouble <input type="checkbox"/> Quick stop by trouble <input type="checkbox"/> Warning locked <input type="checkbox"/> Warning <input checked="" type="checkbox"/> <b>Information</b>	
<b>Cause</b>	<b>Remedy</b>
EnDat encoder defective.	Check EnDat encoder.

**Failure of motor phase U [0x007b002d]**

Module ID (decimal)	Error ID (decimal)
123: Motor control	45
<b>Reaction</b> (Lenze setting in bold)	
Setting: <a href="#">C00597</a> ( <input checked="" type="checkbox"/> Adjustable response) <input checked="" type="checkbox"/> <b>None</b> <input type="checkbox"/> System fault <input checked="" type="checkbox"/> Fault <input checked="" type="checkbox"/> Trouble <input checked="" type="checkbox"/> Quick stop by trouble <input checked="" type="checkbox"/> Warning locked <input checked="" type="checkbox"/> Warning <input type="checkbox"/> Information	
<b>Cause</b>	<b>Remedy</b>
U phase interruption of motor cable.	<ul style="list-style-type: none"> <li>• Check cabling between the controller and motor.</li> <li>• Check parameter setting (<a href="#">C00599</a>).</li> </ul>

**Failure of motor phase V [0x007b002e]**

Module ID (decimal)	Error ID (decimal)
123: Motor control	46
<b>Reaction</b> (Lenze setting in bold)	
Setting: <a href="#">C00597</a> ( <input checked="" type="checkbox"/> Adjustable response) <input checked="" type="checkbox"/> <b>None</b> <input type="checkbox"/> System fault <input checked="" type="checkbox"/> Fault <input checked="" type="checkbox"/> Trouble <input checked="" type="checkbox"/> Quick stop by trouble <input checked="" type="checkbox"/> Warning locked <input checked="" type="checkbox"/> Warning <input type="checkbox"/> Information	
<b>Cause</b>	<b>Remedy</b>
V phase interruption of the motor cable.	<ul style="list-style-type: none"> <li>• Check cabling between the controller and motor.</li> <li>• Check parameter setting (<a href="#">C00599</a>).</li> </ul>

## Failure of motor phase W [0x007b002f]

Module ID (decimal)	Error ID (decimal)
123: Motor control	47
<b>Reaction</b> (Lenze setting in bold)	
Setting: <a href="#">C00597</a> ( <input checked="" type="checkbox"/> Adjustable response)	
<input checked="" type="checkbox"/> None <input type="checkbox"/> System fault <input checked="" type="checkbox"/> Fault <input checked="" type="checkbox"/> Trouble <input checked="" type="checkbox"/> Quick stop by trouble <input checked="" type="checkbox"/> Warning locked <input checked="" type="checkbox"/> Warning <input type="checkbox"/> Information	
<b>Cause</b>	<b>Remedy</b>
W phase interruption of the motor cable.	<ul style="list-style-type: none"> <li>• Check cabling between the controller and motor.</li> <li>• Check parameter setting (<a href="#">C00599</a>).</li> </ul>

## Electronic nameplate: Data loaded [0x007b0030]

Module ID (decimal)	Error ID (decimal)
123: Motor control	48
<b>Reaction</b> (Lenze setting in bold)	
<input type="checkbox"/> None <input type="checkbox"/> System fault <input type="checkbox"/> Fault <input type="checkbox"/> Trouble <input type="checkbox"/> Quick stop by trouble <input type="checkbox"/> Warning locked <input type="checkbox"/> Warning <input checked="" type="checkbox"/> Information	
<b>Cause</b>	<b>Remedy</b>
New electronic nameplate (ENP) has been found.	- (Information only)

## Electronic nameplate: Not found [0x007b0031]

Module ID (decimal)	Error ID (decimal)
123: Motor control	49
<b>Reaction</b> (Lenze setting in bold)	
<input type="checkbox"/> None <input type="checkbox"/> System fault <input type="checkbox"/> Fault <input type="checkbox"/> Trouble <input type="checkbox"/> Quick stop by trouble <input type="checkbox"/> Warning locked <input type="checkbox"/> Warning <input checked="" type="checkbox"/> Information	
<b>Cause</b>	<b>Remedy</b>
Electronic nameplate (ENP) is not available.	- (Information only)

## Electronic nameplate: Encoder protocol unknown [0x007b0032]

Module ID (decimal)	Error ID (decimal)
123: Motor control	50
<b>Reaction</b> (Lenze setting in bold)	
<input type="checkbox"/> None <input type="checkbox"/> System fault <input type="checkbox"/> Fault <input type="checkbox"/> Trouble <input type="checkbox"/> Quick stop by trouble <input type="checkbox"/> Warning locked <input type="checkbox"/> Warning <input checked="" type="checkbox"/> Information	
<b>Cause</b>	<b>Remedy</b>
The connected motor with feedback is not supported by the controller firmware.	Check drive dimensioning.

## Electronic nameplate: Encoder signal unknown [0x007b0033]

Module ID (decimal)	Error ID (decimal)
123: Motor control	51
<b>Reaction</b> (Lenze setting in bold)	
<input type="checkbox"/> None <input type="checkbox"/> System fault <input type="checkbox"/> Fault <input type="checkbox"/> Trouble <input type="checkbox"/> Quick stop by trouble <input type="checkbox"/> Warning locked <input type="checkbox"/> Warning <input checked="" type="checkbox"/> Information	
<b>Cause</b>	<b>Remedy</b>
The connected motor with feedback is not supported by the controller firmware.	Check drive dimensioning.

**Internal communication error (DMA) [0x007b0034]**

Module ID (decimal)	Error ID (decimal)
123: Motor control	52
<b>Reaction</b> (Lenze setting in bold)	
<input type="checkbox"/> None <input checked="" type="checkbox"/> <b>System fault</b> <input type="checkbox"/> Fault <input type="checkbox"/> Trouble <input type="checkbox"/> Quick stop by trouble <input type="checkbox"/> Warning locked <input type="checkbox"/> Warning <input type="checkbox"/> Information	
<b>Cause</b>	<b>Remedy</b>
Internal error.	Please contact Lenze.

**Controller: Overload during acceleration phases [0x007b0035]**

Module ID (decimal)	Error ID (decimal)
123: Motor control	53
<b>Reaction</b> (Lenze setting in bold)	
<input type="checkbox"/> None <input type="checkbox"/> System fault <input checked="" type="checkbox"/> <b>Fault</b> <input type="checkbox"/> Trouble <input type="checkbox"/> Quick stop by trouble <input type="checkbox"/> Warning locked <input type="checkbox"/> Warning <input type="checkbox"/> Information	
<b>Cause</b>	<b>Remedy</b>
Frequent or too long acceleration processes.	<ul style="list-style-type: none"> <li>• Check drive dimensioning.</li> <li>• Reduce steepness of acceleration ramps.</li> </ul>

**Internal communication error (MCTRL host) [0x007b0036]**

Module ID (decimal)	Error ID (decimal)
123: Motor control	54
<b>Reaction</b> (Lenze setting in bold)	
<input type="checkbox"/> None <input checked="" type="checkbox"/> <b>System fault</b> <input type="checkbox"/> Fault <input type="checkbox"/> Trouble <input type="checkbox"/> Quick stop by trouble <input type="checkbox"/> Warning locked <input type="checkbox"/> Warning <input type="checkbox"/> Information	
<b>Cause</b>	<b>Remedy</b>
Internal error.	Please contact Lenze.

**PLC configuration invalid [0x007b0037]**

Module ID (decimal)	Error ID (decimal)
123: Motor control	55
<b>Reaction</b> (Lenze setting in bold)	
<input type="checkbox"/> None <input type="checkbox"/> System fault <input checked="" type="checkbox"/> <b>Fault</b> <input type="checkbox"/> Trouble <input type="checkbox"/> Quick stop by trouble <input type="checkbox"/> Warning locked <input type="checkbox"/> Warning <input type="checkbox"/> Information	
<b>Cause</b>	<b>Remedy</b>
An invalid control configuration has occurred.	Load a different application.

**Motor parameter identification was cancelled [0x007b0038]**

Module ID (decimal)	Error ID (decimal)
123: Motor control	56
<b>Reaction</b> (Lenze setting in bold)	
<input type="checkbox"/> None <input type="checkbox"/> System fault <input checked="" type="checkbox"/> <b>Fault</b> <input type="checkbox"/> Trouble <input type="checkbox"/> Quick stop by trouble <input type="checkbox"/> Warning locked <input type="checkbox"/> Warning <input type="checkbox"/> Information	
<b>Cause</b>	<b>Remedy</b>
The motor current during identification was too high.	<ul style="list-style-type: none"> <li>• The motor must not move during identification.</li> <li>• Check motor parameters.</li> </ul>

---

**Electronic nameplate: Data outside the parameter limits [0x007b0039]**

Module ID (decimal)	Error ID (decimal)
123: Motor control	57
<b>Reaction</b> (Lenze setting in bold)	
<input type="checkbox"/> None <input type="checkbox"/> System fault <input type="checkbox"/> Fault <input type="checkbox"/> Trouble <input type="checkbox"/> Quick stop by trouble <input type="checkbox"/> Warning locked <input type="checkbox"/> Warning <input checked="" type="checkbox"/> <b>Information</b>	
<b>Cause</b>	<b>Remedy</b>
The motor parameters of the electronic nameplate are outside of the limit values of the controller and therefore cannot be accepted.	Please contact Lenze.

**Hiperface encoder: Transmission error [0x007b003a]**

Module ID (decimal)	Error ID (decimal)
123: Motor control	58
<b>Reaction</b> (Lenze setting in bold)	
<input type="checkbox"/> None <input type="checkbox"/> System fault <input type="checkbox"/> Fault <input type="checkbox"/> Trouble <input type="checkbox"/> Quick stop by trouble <input type="checkbox"/> Warning locked <input type="checkbox"/> Warning <input checked="" type="checkbox"/> <b>Information</b>	
<b>Cause</b>	<b>Remedy</b>
<ul style="list-style-type: none"> <li>Encoder signal interferences (EMC).</li> <li>Encoder cable interrupted.</li> <li>Encoder defective.</li> <li>Faulty parameter setting of the encoder.</li> </ul> <p><b>Note:</b> This information is always supplied together with the "I/O error - encoder communication" error message and is entered in the logbook even if the encoder monitoring is deactivated (<a href="#">C00580</a>).</p>	<ul style="list-style-type: none"> <li>Check encoder cable, use shorter encoder cable if required.</li> <li>Check encoder.</li> <li>Check parameter setting (<a href="#">C00420</a>, <a href="#">C00421</a>, <a href="#">C00422</a>).</li> </ul>

**Hiperface encoder: Command error [0x007b003b]**

Module ID (decimal)	Error ID (decimal)
123: Motor control	59
<b>Reaction</b> (Lenze setting in bold)	
<input type="checkbox"/> None <input type="checkbox"/> System fault <input type="checkbox"/> Fault <input type="checkbox"/> Trouble <input type="checkbox"/> Quick stop by trouble <input type="checkbox"/> Warning locked <input type="checkbox"/> Warning <input checked="" type="checkbox"/> <b>Information</b>	
<b>Cause</b>	<b>Remedy</b>
<ul style="list-style-type: none"> <li>Encoder signal interferences (EMC).</li> <li>Encoder cable interrupted.</li> <li>Encoder defective.</li> <li>Faulty parameter setting of the encoder.</li> </ul> <p><b>Note:</b> This information is always supplied together with the "I/O error - encoder communication" error message and is entered in the logbook even if the encoder monitoring is deactivated (<a href="#">C00580</a>).</p>	<ul style="list-style-type: none"> <li>Check encoder cable, use shorter encoder cable if required.</li> <li>Check encoder.</li> <li>Check parameter setting (<a href="#">C00420</a>, <a href="#">C00421</a>, <a href="#">C00422</a>).</li> </ul>

## HiPerface encoder: Unknown encoder [0x007b003c]

Module ID (decimal)	Error ID (decimal)
123: Motor control	60
<b>Reaction</b> (Lenze setting in bold)	
<input type="checkbox"/> None <input type="checkbox"/> System fault <input type="checkbox"/> Fault <input type="checkbox"/> Trouble <input type="checkbox"/> Quick stop by trouble <input type="checkbox"/> Warning locked <input type="checkbox"/> Warning <input checked="" type="checkbox"/> <b>Information</b>	
<b>Cause</b>	<b>Remedy</b>
Encoder is not supported by the controller firmware.	<ul style="list-style-type: none"> <li>• Exchange encoder for known type.</li> <li>• <a href="#">From software version V4.0</a>: Parameterise the unknown encoder with the codes <a href="#">C00414</a> (type code) and <a href="#">C00415</a> (number of revolutions).</li> </ul>

## HiPerface encoder: Position initialisation error [0x007b003d]

Module ID (decimal)	Error ID (decimal)
123: Motor control	61
<b>Reaction</b> (Lenze setting in bold)	
<input type="checkbox"/> None <input type="checkbox"/> System fault <input type="checkbox"/> Fault <input type="checkbox"/> Trouble <input type="checkbox"/> Quick stop by trouble <input type="checkbox"/> Warning locked <input type="checkbox"/> Warning <input checked="" type="checkbox"/> <b>Information</b>	
<b>Cause</b>	<b>Remedy</b>
<p>A digital readout of the absolute encoder is only possible at standstill.</p> <p>The readout is activated by the following actions:</p> <ul style="list-style-type: none"> <li>• Mains switching</li> <li>• Change of <a href="#">C00420</a>, <a href="#">C00422</a> and <a href="#">C00427</a></li> <li>• To "<a href="#">Absolute value encoder: Communication error</a>"</li> <li>• To "<a href="#">Encoder: Open circuit</a>"</li> </ul> <p><b>Note:</b> This information is always supplied together with the "I/O error - encoder communication" error message and is entered in the logbook even if the encoder monitoring is deactivated (<a href="#">C00580</a>).</p>	Prevent coasting of the machine while the absolute encoder is read out.

## Encoder monitoring: Pulse deviation detected [0x007b003e]

Module ID (decimal)	Error ID (decimal)
123: Motor control	62
<b>Reaction</b> (Lenze setting in bold)	
<b>Setting:</b> <a href="#">C00621</a> ( <input checked="" type="checkbox"/> Adjustable response)	
<input checked="" type="checkbox"/> <b>None</b> <input type="checkbox"/> System fault <input checked="" type="checkbox"/> Fault <input checked="" type="checkbox"/> Trouble <input checked="" type="checkbox"/> Quick stop by trouble <input checked="" type="checkbox"/> Warning locked <input checked="" type="checkbox"/> Warning <input type="checkbox"/> Information	
<b>Cause</b>	<b>Remedy</b>
<ul style="list-style-type: none"> <li>• Encoder signal interferences (EMC).</li> <li>• Encoder cable interrupted.</li> <li>• Encoder defective.</li> <li>• Faulty parameter setting of the encoder.</li> </ul>	<ul style="list-style-type: none"> <li>• Check encoder cable, use shorter encoder cable if required.</li> <li>• Check encoder.</li> <li>• Check parameter setting (<a href="#">C00422</a>).</li> <li>• Possibly switch off monitoring (<a href="#">C00621</a>).</li> </ul>

## Failure of a mains phase [0x007b003f]

Module ID (decimal)	Error ID (decimal)
123: Motor control	63
<b>Reaction</b> (Lenze setting in bold)	
<input type="checkbox"/> None <input type="checkbox"/> System fault <input checked="" type="checkbox"/> <b>Fault</b> <input type="checkbox"/> Trouble <input type="checkbox"/> Quick stop by trouble <input type="checkbox"/> Warning locked <input type="checkbox"/> Warning <input type="checkbox"/> Information	
<b>Cause</b>	
Missing mains phase. <b>Note:</b> This monitoring is only available for devices $\geq 75$ kW (type 8S and bigger).	
<b>Remedy</b>	
Check mains connection.	

## Brake chopper: Ixt &gt; C00570 [0x007b0040]

Module ID (decimal)	Error ID (decimal)
123: Motor control	64
<b>Reaction</b> (Lenze setting in bold)	
Setting: <a href="#">C00569</a> ( <input checked="" type="checkbox"/> Adjustable response) <input checked="" type="checkbox"/> None <input type="checkbox"/> System fault <input checked="" type="checkbox"/> Fault <input checked="" type="checkbox"/> Trouble <input checked="" type="checkbox"/> Quick stop by trouble <input checked="" type="checkbox"/> Warning locked <input checked="" type="checkbox"/> <b>Warning</b> <input type="checkbox"/> Information	
<b>Cause</b>	
Frequent and too long braking.	
<b>Remedy</b>	
<ul style="list-style-type: none"> <li>• Check drive dimensioning.</li> <li>• Check setting in <a href="#">C00570</a>.</li> </ul>	

## Brake resistor: I2t &gt; C00572 [0x007b0041]

Module ID (decimal)	Error ID (decimal)
123: Motor control	65
<b>Reaction</b> (Lenze setting in bold)	
Setting: <a href="#">C00571</a> ( <input checked="" type="checkbox"/> Adjustable response) <input checked="" type="checkbox"/> None <input type="checkbox"/> System fault <input checked="" type="checkbox"/> Fault <input checked="" type="checkbox"/> Trouble <input checked="" type="checkbox"/> Quick stop by trouble <input checked="" type="checkbox"/> Warning locked <input checked="" type="checkbox"/> <b>Warning</b> <input type="checkbox"/> Information	
<b>Cause</b>	
Frequent and too long braking.	
<b>Remedy</b>	
<ul style="list-style-type: none"> <li>• Check drive dimensioning.</li> <li>• Check setting in <a href="#">C00572</a>.</li> <li>• Check settings for brake resistor (<a href="#">C00129</a>, <a href="#">C00130</a>, <a href="#">C00131</a>).</li> </ul>	

## Power section is defect [0x007b0042]

Module ID (decimal)	Error ID (decimal)
123: Motor control	66
<b>Reaction</b> (Lenze setting in bold)	
<input type="checkbox"/> None <input checked="" type="checkbox"/> <b>System fault</b> <input type="checkbox"/> Fault <input type="checkbox"/> Trouble <input type="checkbox"/> Quick stop by trouble <input type="checkbox"/> Warning locked <input type="checkbox"/> Warning <input type="checkbox"/> Information	
<b>Cause</b>	
Device error	
<b>Remedy</b>	
Mains switching <ul style="list-style-type: none"> <li>• Please contact Lenze if the problem occurs again.</li> </ul>	



## Controller: Clamp operation [0x007b0047]

Module ID (decimal)	Error ID (decimal)
123: Motor control	71
<b>Reaction</b> (Lenze setting in bold)	
<input type="checkbox"/> None <input type="checkbox"/> System fault <input type="checkbox"/> Fault <input type="checkbox"/> Trouble <input type="checkbox"/> Quick stop by trouble <input type="checkbox"/> Warning locked <input type="checkbox"/> Warning <input checked="" type="checkbox"/> <b>Information</b>	
<b>Cause</b>	<b>Remedy</b>
Actual motor current is higher than the maximum device current ( <a href="#">C00789</a> ).	<ul style="list-style-type: none"> <li>• Increase speed setpoint ramps.</li> <li>• Optimise I<sub>max</sub> controller.</li> </ul>

## Pole position recognition cancelled [0x007b004a]

Module ID (decimal)	Error ID (decimal)
123: Motor control	74
<b>Reaction</b> (Lenze setting in bold)	
Setting: <a href="#">C00640</a> ( <input checked="" type="checkbox"/> Adjustable response)	
<input checked="" type="checkbox"/> None <input type="checkbox"/> System fault <input checked="" type="checkbox"/> <b>Fault</b> <input type="checkbox"/> Trouble <input type="checkbox"/> Quick stop by trouble <input checked="" type="checkbox"/> Warning locked <input type="checkbox"/> Warning <input type="checkbox"/> Information	
<b>Cause</b>	<b>Remedy</b>
<a href="#">From software version V4.0</a> An error occurred during the pole position identification. The pole position identification could not be completed successfully.	<ul style="list-style-type: none"> <li>• Check whether all requirements for an identification of the pole position are fulfilled.</li> <li>• Ensure that the machine is not braked or blocked during the pole position identification.</li> <li>• Repeat the pole position identification.</li> </ul>

## Motor switched off [0x007b004c]

Module ID (decimal)	Error ID (decimal)
123: Motor control	76
<b>Reaction</b> (Lenze setting in bold)	
Setting: <a href="#">C00597</a> ( <input checked="" type="checkbox"/> Adjustable response)	
<input checked="" type="checkbox"/> <b>None</b> <input type="checkbox"/> System fault <input checked="" type="checkbox"/> <b>Fault</b> <input checked="" type="checkbox"/> <b>Trouble</b> <input checked="" type="checkbox"/> Quick stop by trouble <input checked="" type="checkbox"/> Warning locked <input checked="" type="checkbox"/> Warning <input type="checkbox"/> Information	
<b>Cause</b>	<b>Remedy</b>
<a href="#">From software version V5.0</a> Interruption of several motor cable phases.	Check cabling between the controller and motor.

## EnDat encoder: Transmission error [0x007b004e]

Module ID (decimal)	Error ID (decimal)
123: Motor control	78
<b>Reaction</b> (Lenze setting in bold)	
<input type="checkbox"/> None <input type="checkbox"/> System fault <input type="checkbox"/> Fault <input type="checkbox"/> Trouble <input type="checkbox"/> Quick stop by trouble <input type="checkbox"/> Warning locked <input type="checkbox"/> Warning <input checked="" type="checkbox"/> <b>Information</b>	
<b>Cause</b>	<b>Remedy</b>
<ul style="list-style-type: none"> <li>• Encoder signal interferences (EMC).</li> <li>• Encoder cable interrupted.</li> <li>• Encoder defective.</li> <li>• Faulty parameter setting of the encoder.</li> </ul> <b>Note:</b> This information is always supplied together with the "I/O error - encoder communication" error message and is entered in the logbook even if the encoder monitoring is deactivated ( <a href="#">C00580</a> ).	<ul style="list-style-type: none"> <li>• Check encoder cable, use shorter encoder cable if required.</li> <li>• Check encoder.</li> <li>• Check parameter setting (<a href="#">C00420</a>, <a href="#">C00421</a>, <a href="#">C00422</a>).</li> </ul>

## EnDat encoder: Command error [0x007b004f]

Module ID (decimal)	Error ID (decimal)
123: Motor control	79
<b>Reaction</b> (Lenze setting in bold)	
<input type="checkbox"/> None <input type="checkbox"/> System fault <input type="checkbox"/> Fault <input type="checkbox"/> Trouble <input type="checkbox"/> Quick stop by trouble <input type="checkbox"/> Warning locked <input type="checkbox"/> Warning <input checked="" type="checkbox"/> <b>Information</b>	
<b>Cause</b>	<b>Remedy</b>
<ul style="list-style-type: none"> <li>Encoder signal interferences (EMC).</li> <li>Encoder cable interrupted.</li> <li>Encoder defective.</li> <li>Faulty parameter setting of the encoder.</li> </ul> <p><b>Note:</b> This information is always supplied together with the "I/O error - encoder communication" error message and is entered in the logbook even if the encoder monitoring is deactivated (<a href="#">C00580</a>).</p>	<ul style="list-style-type: none"> <li>Check encoder cable, use shorter encoder cable if required.</li> <li>Check encoder.</li> <li>Check parameter setting (<a href="#">C00420</a>, <a href="#">C00421</a>, <a href="#">C00422</a>).</li> </ul>

## EnDat encoder: Position initialisation error [0x007b0050]

Module ID (decimal)	Error ID (decimal)
123: Motor control	80
<b>Reaction</b> (Lenze setting in bold)	
<input type="checkbox"/> None <input type="checkbox"/> System fault <input type="checkbox"/> Fault <input type="checkbox"/> Trouble <input type="checkbox"/> Quick stop by trouble <input type="checkbox"/> Warning locked <input type="checkbox"/> Warning <input checked="" type="checkbox"/> <b>Information</b>	
<b>Cause</b>	<b>Remedy</b>
<p>A digital readout of the absolute encoder is only possible at standstill.</p> <p>The readout is activated by the following actions:</p> <ul style="list-style-type: none"> <li>Mains switching</li> <li>Change of <a href="#">C00420</a>, <a href="#">C00422</a> and <a href="#">C00427</a></li> <li>To "<a href="#">Absolute value encoder: Communication error</a>"</li> <li>To "<a href="#">Encoder: Open circuit</a>"</li> </ul> <p><b>Note:</b> This information is always supplied together with the "I/O error - encoder communication" error message and is entered in the logbook even if the encoder monitoring is deactivated (<a href="#">C00580</a>).</p>	Prevent coasting of the machine while the absolute encoder is read out.

## Memory module: File system has been formatted [0x007c0000]

Module ID (decimal)	Error ID (decimal)
124: Device command module (C00002)	0
<b>Reaction</b> (Lenze setting in bold)	
<input type="checkbox"/> None <input type="checkbox"/> System fault <input type="checkbox"/> Fault <input type="checkbox"/> Trouble <input type="checkbox"/> Quick stop by trouble <input type="checkbox"/> Warning locked <input type="checkbox"/> Warning <input checked="" type="checkbox"/> <b>Information</b>	
<b>Cause</b>	<b>Remedy</b>
File system of the memory module has been formatted.	- (Information only)

## Memory module: File system has been restored [0x007c0001]

Module ID (decimal)	Error ID (decimal)
124: Device command module (C00002)	1
<b>Reaction</b> (Lenze setting in bold)	
<input type="checkbox"/> None <input type="checkbox"/> System fault <input type="checkbox"/> Fault <input type="checkbox"/> Trouble <input type="checkbox"/> Quick stop by trouble <input type="checkbox"/> Warning locked <input type="checkbox"/> Warning <input checked="" type="checkbox"/> <b>Information</b>	
<b>Cause</b>	<b>Remedy</b>
File system of the memory module has been restored.	- (Information only)

**Analog input 1: Master current < 4 mA [0x007d0000]**

Module ID (decimal)	Error ID (decimal)
125: Processing of analog inputs/outputs	0
<b>Reaction</b> (Lenze setting in bold)	
Setting: <a href="#">C00598</a> ( <input checked="" type="checkbox"/> Adjustable response)	
<input checked="" type="checkbox"/> None <input type="checkbox"/> System fault <input checked="" type="checkbox"/> <b>Fault</b> <input checked="" type="checkbox"/> Trouble <input checked="" type="checkbox"/> Quick stop by trouble <input checked="" type="checkbox"/> Warning locked <input checked="" type="checkbox"/> Warning <input checked="" type="checkbox"/> Information	
<b>Cause</b>	
Master current is in the impermissible range -4 ... +4 mA, e. g. due to a cable break or a defective master current value encoder.	
<ul style="list-style-type: none"> <li>Only for parameterisation as master current input (see <a href="#">C00034</a>).</li> </ul>	
<b>Remedy</b>	
Remove cable break.	

**PLC configuration invalid [0x007d0001]**

Module ID (decimal)	Error ID (decimal)
125: Processing of analog inputs/outputs	1
<b>Reaction</b> (Lenze setting in bold)	
<input type="checkbox"/> None <input type="checkbox"/> System fault <input checked="" type="checkbox"/> <b>Fault</b> <input type="checkbox"/> Trouble <input type="checkbox"/> Quick stop by trouble <input type="checkbox"/> Warning locked <input type="checkbox"/> Warning <input type="checkbox"/> Information	
<b>Cause</b>	
An invalid control configuration has occurred.	
<b>Remedy</b>	
Load a different application.	

**Communication error between device and device module [0x007f0002]**

Module ID (decimal)	Error ID (decimal)
127: Interface to the intelligent communication module	2
<b>Reaction</b> (Lenze setting in bold)	
Setting: <a href="#">C01501</a> ( <input checked="" type="checkbox"/> Adjustable response)	
<input checked="" type="checkbox"/> <b>None</b> <input type="checkbox"/> System fault <input checked="" type="checkbox"/> <b>Fault</b> <input type="checkbox"/> Trouble <input checked="" type="checkbox"/> Quick stop by trouble <input checked="" type="checkbox"/> Warning locked <input checked="" type="checkbox"/> Warning <input type="checkbox"/> Information	
<b>Cause</b>	
Communication between the controller and extension module is interrupted, e.g. due to disturbances in the ambience (EMC), defective hardware, or loose contact.	
<ul style="list-style-type: none"> <li>This monitoring is designed for safe process data communication.</li> </ul>	
<b>Remedy</b>	
<ul style="list-style-type: none"> <li>Eliminate EMC interference.</li> <li>Switch off inverter, correctly plug in the module, switch on the inverter again.</li> <li>Switch mains or restart inverter.</li> <li>Replace module/inverter.</li> <li>Please contact Lenze if the problem occurs again.</li> </ul>	

**Communication with module in MXI1 interrupted [0x007f0003]**

Module ID (decimal)	Error ID (decimal)
127: Interface to the intelligent communication module	3
<b>Reaction</b> (Lenze setting in bold)	
<input type="checkbox"/> None <input type="checkbox"/> System fault <input type="checkbox"/> Fault <input type="checkbox"/> Trouble <input type="checkbox"/> Quick stop by trouble <input type="checkbox"/> Warning locked <input type="checkbox"/> Warning <input checked="" type="checkbox"/> <b>Information</b>	
<b>Cause</b>	
Communication between the controller and the extension module in module slot MXI1 cannot be established.	
<b>Remedy</b>	
<ul style="list-style-type: none"> <li>Switch off controller, plug module correctly in module slot MXI1, switch on controller again.</li> <li>If the problem occurs again, replace the module.</li> </ul>	

### Communication with module in MX12 interrupted [0x007f0004]

Module ID (decimal)	Error ID (decimal)
127: Interface to the intelligent communication module	4
<b>Reaction</b> (Lenze setting in bold)	
<input type="checkbox"/> None <input type="checkbox"/> System fault <input type="checkbox"/> Fault <input type="checkbox"/> Trouble <input type="checkbox"/> Quick stop by trouble <input type="checkbox"/> Warning locked <input type="checkbox"/> Warning <input checked="" type="checkbox"/> <b>Information</b>	
<b>Cause</b>	<b>Remedy</b>
Communication between the controller and the extension module in module slot MX12 cannot be established.	<ul style="list-style-type: none"> <li>• Switch off controller, plug module correctly in module slot MX12, switch on controller again.</li> <li>• If the problem occurs again, replace the module.</li> </ul>

### CAN on board: Bus off [0x00830000]

Module ID (decimal)	Error ID (decimal)
131: "CAN on board": CAN dispatcher	0
<b>Reaction</b> (Lenze setting in bold)	
Setting: <a href="#">C00595</a> ( <input checked="" type="checkbox"/> Adjustable response)	
<input checked="" type="checkbox"/> <b>None</b> <input type="checkbox"/> System fault <input checked="" type="checkbox"/> Fault <input checked="" type="checkbox"/> Trouble <input checked="" type="checkbox"/> Quick stop by trouble <input checked="" type="checkbox"/> Warning locked <input checked="" type="checkbox"/> Warning <input checked="" type="checkbox"/> Information	
<b>Cause</b>	<b>Remedy</b>
CAN on board: "Bus-Off" state <ul style="list-style-type: none"> <li>• Received too many faulty telegrams.</li> <li>• Defective cable (e.g. loose contact).</li> <li>• Two nodes with the same ID.</li> </ul>	<ul style="list-style-type: none"> <li>• Remove fault (e.g. EMC).</li> <li>• Remove loose contact, screw down adapter.</li> <li>• Assign different IDs to nodes.</li> </ul>

### CAN on board: Invalid node address 0 [0x00830001]

Module ID (decimal)	Error ID (decimal)
131: "CAN on board": CAN dispatcher	1
<b>Reaction</b> (Lenze setting in bold)	
<input type="checkbox"/> None <input type="checkbox"/> System fault <input type="checkbox"/> Fault <input type="checkbox"/> Trouble <input type="checkbox"/> Quick stop by trouble <input type="checkbox"/> Warning locked <input checked="" type="checkbox"/> <b>Warning</b> <input type="checkbox"/> Information	
<b>Cause</b>	<b>Remedy</b>
CAN on board: initialisation error <ul style="list-style-type: none"> <li>• The hardware allocation of the node address was selected via DIP switches, and the DIP switches of the node address are all on zero.</li> </ul> <b>Note:</b> Instead of the impermissible node address 0, node address 1 is used.	<ul style="list-style-type: none"> <li>• Set a non-zero node address by means of the DIP switches and then switch mains.</li> <li>• Activation of the software allocation of the node number by switching over DIP switch 2, then switch mains.</li> </ul>

### CAN on board: Basic configuration invalid [0x00830002]

Module ID (decimal)	Error ID (decimal)
131: "CAN on board": CAN dispatcher	2
<b>Reaction</b> (Lenze setting in bold)	
<input type="checkbox"/> None <input type="checkbox"/> System fault <input type="checkbox"/> Fault <input type="checkbox"/> Trouble <input type="checkbox"/> Quick stop by trouble <input checked="" type="checkbox"/> <b>Warning locked</b> <input type="checkbox"/> Warning <input type="checkbox"/> Information	
<b>Cause</b>	<b>Remedy</b>
CAN on board: configuration error <ul style="list-style-type: none"> <li>• Faulty download of an Engineer or PLC Designer project</li> <li>• Invalid CAN settings according to DS301V402 in the Engineer or PLC Designer.</li> </ul>	<ul style="list-style-type: none"> <li>• Repeat download</li> <li>• Correct CAN settings in the project and regenerate project.</li> </ul>

## CAN on board: Heartbeat error index 1 ... 32 [0x00840000 ... 0x0084001f]

Module ID (decimal)	Error ID (decimal)
132: "CAN on board": CAN-NMT handler	0 ... 31
<b>Reaction</b> (Lenze setting in bold)	
Setting: <a href="#">C00613/1...32</a> <input checked="" type="checkbox"/> Adjustable response	
<input checked="" type="checkbox"/> None <input type="checkbox"/> System fault <input checked="" type="checkbox"/> Fault <input checked="" type="checkbox"/> Trouble <input checked="" type="checkbox"/> Quick stop by trouble <input checked="" type="checkbox"/> Warning locked <input checked="" type="checkbox"/> Warning <input checked="" type="checkbox"/> Information	
Cause	Remedy
CAN on board: Cyclic node monitoring <ul style="list-style-type: none"> <li>Node station has not received a heartbeat telegram from node 1 ... 32 within the defined time.</li> </ul>	<ul style="list-style-type: none"> <li>Reactivate CAN node by mains switching, restart of the controller (<a href="#">C00002</a>="11000") or CAN reset node.</li> <li>Select a different heartbeat producer monitoring time or switch off monitoring and reset locked error status, if necessary.</li> </ul> Tip: Save the current parameter set before mains switching and restart of the controller ( <a href="#">C00002</a> ="11").

## CAN on board: Lifeguarding error [0x00840020]

Module ID (decimal)	Error ID (decimal)
132: "CAN on board": CAN-NMT handler	32
<b>Reaction</b> (Lenze setting in bold)	
Setting: <a href="#">C00614</a> <input checked="" type="checkbox"/> Adjustable response	
<input checked="" type="checkbox"/> None <input type="checkbox"/> System fault <input checked="" type="checkbox"/> Fault <input checked="" type="checkbox"/> Trouble <input checked="" type="checkbox"/> Quick stop by trouble <input checked="" type="checkbox"/> Warning locked <input checked="" type="checkbox"/> Warning <input checked="" type="checkbox"/> Information	
Cause	Remedy
CAN on board: Cyclic node monitoring <ul style="list-style-type: none"> <li>Slave response: Maximum time between two node guarding telegrams (remote transmission request telegram) from the master has been exceeded.</li> </ul>	Select a different Lifeguarding monitoring time or switch off monitoring.

## CAN on board: Faulty NMT slave configuration [0x00840021]

Module ID (decimal)	Error ID (decimal)
132: "CAN on board": CAN-NMT handler	33
<b>Reaction</b> (Lenze setting in bold)	
<input type="checkbox"/> None <input type="checkbox"/> System fault <input type="checkbox"/> Fault <input type="checkbox"/> Trouble <input type="checkbox"/> Quick stop by trouble <input checked="" type="checkbox"/> Warning locked <input type="checkbox"/> Warning <input type="checkbox"/> Information	
Cause	Remedy
CAN on board: A configuration error has occurred in the network management of the CAN slave. <ul style="list-style-type: none"> <li>Faulty download of an Engineer or PLC Designer project</li> <li>Invalid CAN settings according to DS301V402 in the Engineer or PLC Designer.</li> <li>Incorrect parameterisation of node guarding or heartbeat.</li> </ul>	<ul style="list-style-type: none"> <li>Repeat download</li> <li>Correct CAN settings in the project and regenerate project.</li> </ul>

## CAN on board: Faulty emergency configuration [0x00850000]

Module ID (decimal)	Error ID (decimal)
133: "CAN on board": CAN emergency handler	0
<b>Reaction</b> (Lenze setting in bold)	
<input type="checkbox"/> None <input type="checkbox"/> System fault <input type="checkbox"/> Fault <input type="checkbox"/> Trouble <input type="checkbox"/> Quick stop by trouble <input checked="" type="checkbox"/> <b>Warning locked</b> <input type="checkbox"/> Warning <input type="checkbox"/> Information	
<b>Cause</b>	<b>Remedy</b>
CAN on board: CAN emergency configuration is faulty. <ul style="list-style-type: none"> <li>• Faulty download of an Engineer or PLC Designer project</li> <li>• Invalid CAN emergency settings according to DS301V402 in the Engineer or PLC Designer.</li> </ul>	<ul style="list-style-type: none"> <li>• Repeat download</li> <li>• Correct CAN settings in the project and regenerate project.</li> </ul>

## CAN on board: Node guarding error 1 ... 32 [0x00860000 ... 0x0086001f]

Module ID (decimal)	Error ID (decimal)
134: "CAN on board": CAN-NMT master	0 ... 31
<b>Reaction</b> (Lenze setting in bold)	
<input checked="" type="checkbox"/> <b>None</b> <input type="checkbox"/> System fault <input checked="" type="checkbox"/> Fault <input checked="" type="checkbox"/> Trouble <input checked="" type="checkbox"/> Quick stop by trouble <input checked="" type="checkbox"/> Warning locked <input checked="" type="checkbox"/> Warning <input checked="" type="checkbox"/> Information	
Setting: <a href="#">C00612/1...32</a> ( <input checked="" type="checkbox"/> Adjustable response)	
<b>Cause</b>	<b>Remedy</b>
CAN on board: Cyclic node monitoring <ul style="list-style-type: none"> <li>• CAN master has not received a response to a node guarding telegram (remote transmission request telegram) from node 1 ... 32 within the defined time.</li> </ul>	<ul style="list-style-type: none"> <li>• Reactivate CAN node by mains switching, restart of the controller (<a href="#">C00002</a>="11000") or CAN reset node.</li> <li>• Select a different node guarding monitoring time or switch off monitoring.</li> <li>• Reset potentially caught error status.</li> </ul> Tip: Save the current parameter set before mains switching and restart of the controller ( <a href="#">C00002</a> ="11").

## CAN on board: Faulty NMT master configuration [0x00860020]

Module ID (decimal)	Error ID (decimal)
134: "CAN on board": CAN-NMT master	32
<b>Reaction</b> (Lenze setting in bold)	
<input type="checkbox"/> None <input type="checkbox"/> System fault <input type="checkbox"/> Fault <input type="checkbox"/> Trouble <input type="checkbox"/> Quick stop by trouble <input checked="" type="checkbox"/> <b>Warning locked</b> <input type="checkbox"/> Warning <input type="checkbox"/> Information	
<b>Cause</b>	<b>Remedy</b>
CAN on board: A configuration error has occurred in the network management of the CAN master. <ul style="list-style-type: none"> <li>• Faulty download of an Engineer or PLC Designer project.</li> <li>• Invalid CAN master settings according to DS301V402 and DS405 in the Engineer or PLC Designer.</li> <li>• Incorrect parameterisation of node guarding or heartbeat.</li> </ul>	<ul style="list-style-type: none"> <li>• Repeat download</li> <li>• Correct CAN settings in the project and regenerate project.</li> </ul>

**CAN on board RPDO1: Telegram not received or faulty [0x00870000]**

Module ID (decimal)	Error ID (decimal)
135: "CAN on board": CAN-PDO handler	0
<b>Reaction</b> (Lenze setting in bold)	
Setting: <a href="#">C00591/1</a> ( <input checked="" type="checkbox"/> Adjustable response)	
<input checked="" type="checkbox"/> None <input type="checkbox"/> System fault <input checked="" type="checkbox"/> Fault <input checked="" type="checkbox"/> Trouble <input checked="" type="checkbox"/> Quick stop by trouble <input checked="" type="checkbox"/> Warning locked <input checked="" type="checkbox"/> Warning <input checked="" type="checkbox"/> Information	
Cause	Remedy
CAN on board: CAN-IN 1 error <ul style="list-style-type: none"> <li>• Incorrect PDO telegram length.</li> <li>• Transmission error.</li> <li>• Time monitoring of the PDOs has tripped.</li> </ul>	<ul style="list-style-type: none"> <li>• Set correct telegram length for CAN master (transmitter).</li> <li>• Eliminate trouble in the environment (e. g. EMC).</li> <li>• Select a different time monitoring or switch off time monitoring.</li> </ul>

**CAN on board RPDO2: Telegram not received or faulty [0x00870001]**

Module ID (decimal)	Error ID (decimal)
135: "CAN on board": CAN-PDO handler	1
<b>Reaction</b> (Lenze setting in bold)	
Setting: <a href="#">C00591/2</a> ( <input checked="" type="checkbox"/> Adjustable response)	
<input checked="" type="checkbox"/> None <input type="checkbox"/> System fault <input checked="" type="checkbox"/> Fault <input checked="" type="checkbox"/> Trouble <input checked="" type="checkbox"/> Quick stop by trouble <input checked="" type="checkbox"/> Warning locked <input checked="" type="checkbox"/> Warning <input checked="" type="checkbox"/> Information	
Cause	Remedy
CAN on board: CAN-IN 2 error <ul style="list-style-type: none"> <li>• Incorrect PDO telegram length.</li> <li>• Transmission error.</li> <li>• Time monitoring of the PDOs has tripped.</li> </ul>	<ul style="list-style-type: none"> <li>• Set correct telegram length for CAN master (transmitter).</li> <li>• Eliminate trouble in the environment (e. g. EMC).</li> <li>• Select a different time monitoring or switch off time monitoring.</li> </ul>

**CAN on board RPDO3: Telegram not received or faulty [0x00870002]**

Module ID (decimal)	Error ID (decimal)
135: "CAN on board": CAN-PDO handler	2
<b>Reaction</b> (Lenze setting in bold)	
Setting: <a href="#">C00591/3</a> ( <input checked="" type="checkbox"/> Adjustable response)	
<input checked="" type="checkbox"/> None <input type="checkbox"/> System fault <input checked="" type="checkbox"/> Fault <input checked="" type="checkbox"/> Trouble <input checked="" type="checkbox"/> Quick stop by trouble <input checked="" type="checkbox"/> Warning locked <input checked="" type="checkbox"/> Warning <input checked="" type="checkbox"/> Information	
Cause	Remedy
CAN on board: CAN-IN 3 error <ul style="list-style-type: none"> <li>• Incorrect PDO telegram length.</li> <li>• Transmission error.</li> <li>• Time monitoring of the PDOs has tripped.</li> </ul>	<ul style="list-style-type: none"> <li>• Set correct telegram length for CAN master (transmitter).</li> <li>• Eliminate trouble in the environment (e. g. EMC).</li> <li>• Select a different time monitoring or switch off time monitoring.</li> </ul>

**CAN on board RPDO4: Telegram not received or faulty [0x00870003]**

Module ID (decimal)	Error ID (decimal)
135: "CAN on board": CAN-PDO handler	3
<b>Reaction</b> (Lenze setting in bold)	
Setting: <a href="#">C00591/4</a> ( <input checked="" type="checkbox"/> Adjustable response)	
<input checked="" type="checkbox"/> None <input type="checkbox"/> System fault <input checked="" type="checkbox"/> Fault <input checked="" type="checkbox"/> Trouble <input checked="" type="checkbox"/> Quick stop by trouble <input checked="" type="checkbox"/> Warning locked <input checked="" type="checkbox"/> Warning <input checked="" type="checkbox"/> Information	
Cause	Remedy
CAN on board: CAN-IN 4 error <ul style="list-style-type: none"> <li>• Incorrect PDO telegram length.</li> <li>• Transmission error.</li> <li>• Time monitoring of the PDOs has tripped.</li> </ul>	<ul style="list-style-type: none"> <li>• Set correct telegram length for CAN master (transmitter).</li> <li>• Eliminate trouble in the environment (e. g. EMC).</li> <li>• Select a different time monitoring or switch off time monitoring.</li> </ul>

**CAN on board PDO manager: Faulty configuration [0x00870008]**

Module ID (decimal)	Error ID (decimal)
135: "CAN on board": CAN-PDO handler	8
<b>Reaction (Lenze setting in bold)</b>	
<input type="checkbox"/> None <input type="checkbox"/> System fault <input type="checkbox"/> Fault <input type="checkbox"/> Trouble <input type="checkbox"/> Quick stop by trouble <input checked="" type="checkbox"/> <b>Warning locked</b> <input type="checkbox"/> Warning <input type="checkbox"/> Information	
<b>Cause</b>	<b>Remedy</b>
CAN on board: CAN-PDO configuration error <ul style="list-style-type: none"> <li>• Faulty project download.</li> <li>• Invalid CAN settings according to DS301V402 in the Engineer or PLC Designer.</li> <li>• Mapping variables have incorrect CANopen indices according to DS405.</li> </ul>	<ul style="list-style-type: none"> <li>• Repeat download.</li> <li>• Correct CAN settings in the project and regenerate project.</li> </ul>

**CAN on board SDO server: Faulty configuration [0x00880000]**

Module ID (decimal)	Error ID (decimal)
136: "CAN on board": CAN-SDO server	0
<b>Reaction (Lenze setting in bold)</b>	
<input type="checkbox"/> None <input type="checkbox"/> System fault <input type="checkbox"/> Fault <input type="checkbox"/> Trouble <input type="checkbox"/> Quick stop by trouble <input checked="" type="checkbox"/> <b>Warning locked</b> <input type="checkbox"/> Warning <input type="checkbox"/> Information	
<b>Cause</b>	<b>Remedy</b>
CAN on board: A configuration error has occurred in the CAN SDO server. <ul style="list-style-type: none"> <li>• Faulty project download.</li> <li>• Invalid SDO server settings according to DS301V402 in the Engineer or PLC Designer.</li> </ul>	<ul style="list-style-type: none"> <li>• Repeat download.</li> <li>• Correct CAN settings in the project and regenerate project.</li> </ul>

**CAN on board SDO client: Faulty configuration [0x00890000]**

Module ID (decimal)	Error ID (decimal)
137: "CAN on board": CAN-SDO client	0
<b>Reaction (Lenze setting in bold)</b>	
<input type="checkbox"/> None <input type="checkbox"/> System fault <input type="checkbox"/> Fault <input type="checkbox"/> Trouble <input type="checkbox"/> Quick stop by trouble <input checked="" type="checkbox"/> <b>Warning locked</b> <input type="checkbox"/> Warning <input type="checkbox"/> Information	
<b>Cause</b>	<b>Remedy</b>
CAN on board: A configuration error has occurred in the CAN SDO client. <ul style="list-style-type: none"> <li>• Faulty project download.</li> <li>• Invalid SDO client settings according to DS301V402 in the Engineer or PLC Designer.</li> </ul>	<ul style="list-style-type: none"> <li>• Repeat download</li> <li>• Correct CAN settings in the project and regenerate project.</li> </ul>

**File ProjectSelection.dat defect [0x008c0000]**

Module ID (decimal)	Error ID (decimal)
140: Application project manager	0
<b>Reaction (Lenze setting in bold)</b>	
<input type="checkbox"/> None <input type="checkbox"/> System fault <input checked="" type="checkbox"/> <b>Fault</b> <input type="checkbox"/> Trouble <input type="checkbox"/> Quick stop by trouble <input type="checkbox"/> Warning locked <input type="checkbox"/> Warning <input type="checkbox"/> Information	
<b>Cause</b>	<b>Remedy</b>
Internal error	Reformat memory module (C00002="1030") and repeat project download.



**File ProjectList.dat defect [0x008c0001]**

Module ID (decimal)	Error ID (decimal)
140: Application project manager	1
<b>Reaction</b> (Lenze setting in bold)	
<input type="checkbox"/> None <input type="checkbox"/> System fault <input checked="" type="checkbox"/> <b>Fault</b> <input type="checkbox"/> Trouble <input type="checkbox"/> Quick stop by trouble <input type="checkbox"/> Warning locked <input type="checkbox"/> Warning <input type="checkbox"/> Information	
<b>Cause</b>	<b>Remedy</b>
Internal error	Reformat memory module ( <a href="#">C00002</a> ="1030") and repeat project download.

**File DeviceCFG.dat defect [0x008c0002]**

Module ID (decimal)	Error ID (decimal)
140: Application project manager	2
<b>Reaction</b> (Lenze setting in bold)	
<input type="checkbox"/> None <input type="checkbox"/> System fault <input checked="" type="checkbox"/> <b>Fault</b> <input type="checkbox"/> Trouble <input type="checkbox"/> Quick stop by trouble <input type="checkbox"/> Warning locked <input type="checkbox"/> Warning <input type="checkbox"/> Information	
<b>Cause</b>	<b>Remedy</b>
Internal error	Reformat memory module ( <a href="#">C00002</a> ="1030") and repeat project download.

**File ProjectSelection.dat is missing [0x008c0003]**

Module ID (decimal)	Error ID (decimal)
140: Application project manager	3
<b>Reaction</b> (Lenze setting in bold)	
<input type="checkbox"/> None <input type="checkbox"/> System fault <input checked="" type="checkbox"/> <b>Fault</b> <input type="checkbox"/> Trouble <input type="checkbox"/> Quick stop by trouble <input type="checkbox"/> Warning locked <input type="checkbox"/> Warning <input type="checkbox"/> Information	
<b>Cause</b>	<b>Remedy</b>
Internal error	Reformat memory module ( <a href="#">C00002</a> ="1030") and repeat project download.

**File ProjectList.dat is missing [0x008c0004]**

Module ID (decimal)	Error ID (decimal)
140: Application project manager	4
<b>Reaction</b> (Lenze setting in bold)	
<input type="checkbox"/> None <input type="checkbox"/> System fault <input checked="" type="checkbox"/> <b>Fault</b> <input type="checkbox"/> Trouble <input type="checkbox"/> Quick stop by trouble <input type="checkbox"/> Warning locked <input type="checkbox"/> Warning <input type="checkbox"/> Information	
<b>Cause</b>	<b>Remedy</b>
Internal error	Reformat memory module ( <a href="#">C00002</a> ="1030") and repeat project download.

**File DeviceCFG.dat is missing [0x008c0005]**

Module ID (decimal)	Error ID (decimal)
140: Application project manager	5
<b>Reaction</b> (Lenze setting in bold)	
<input type="checkbox"/> None <input type="checkbox"/> System fault <input checked="" type="checkbox"/> <b>Fault</b> <input type="checkbox"/> Trouble <input type="checkbox"/> Quick stop by trouble <input type="checkbox"/> Warning locked <input type="checkbox"/> Warning <input type="checkbox"/> Information	
<b>Cause</b>	<b>Remedy</b>
Internal error	Reformat memory module ( <a href="#">C00002</a> ="1030") and repeat project download.

**File ProjectSelection.dat invalid [0x008c0006]**

Module ID (decimal)	Error ID (decimal)
140: Application project manager	6
<b>Reaction</b> (Lenze setting in bold)	
<input type="checkbox"/> None <input type="checkbox"/> System fault <input checked="" type="checkbox"/> <b>Fault</b> <input type="checkbox"/> Trouble <input type="checkbox"/> Quick stop by trouble <input type="checkbox"/> Warning locked <input type="checkbox"/> Warning <input type="checkbox"/> Information	
<b>Cause</b>	<b>Remedy</b>
Internal error	Reformat memory module ( <a href="#">C00002</a> ="1030") and repeat project download.

**File ProjectList.dat invalid [0x008c0007]**

Module ID (decimal)	Error ID (decimal)
140: Application project manager	7
<b>Reaction</b> (Lenze setting in bold)	
<input type="checkbox"/> None <input type="checkbox"/> System fault <input checked="" type="checkbox"/> <b>Fault</b> <input type="checkbox"/> Trouble <input type="checkbox"/> Quick stop by trouble <input type="checkbox"/> Warning locked <input type="checkbox"/> Warning <input type="checkbox"/> Information	
<b>Cause</b>	<b>Remedy</b>
Internal error	Reformat memory module ( <a href="#">C00002</a> ="1030") and repeat project download.

**File DeviceCFG.dat invalid [0x008c0008]**

Module ID (decimal)	Error ID (decimal)
140: Application project manager	8
<b>Reaction</b> (Lenze setting in bold)	
<input type="checkbox"/> None <input type="checkbox"/> System fault <input checked="" type="checkbox"/> <b>Fault</b> <input type="checkbox"/> Trouble <input type="checkbox"/> Quick stop by trouble <input type="checkbox"/> Warning locked <input type="checkbox"/> Warning <input type="checkbox"/> Information	
<b>Cause</b>	<b>Remedy</b>
Internal error	Reformat memory module ( <a href="#">C00002</a> ="1030") and repeat project download.

**Project is not loaded [0x008c0009]**

Module ID (decimal)	Error ID (decimal)
140: Application project manager	9
<b>Reaction</b> (Lenze setting in bold)	
<input type="checkbox"/> None <input type="checkbox"/> System fault <input checked="" type="checkbox"/> <b>Fault</b> <input type="checkbox"/> Trouble <input type="checkbox"/> Quick stop by trouble <input type="checkbox"/> Warning locked <input type="checkbox"/> Warning <input type="checkbox"/> Information	
<b>Cause</b>	<b>Remedy</b>
Application could not be loaded because of a file error.	Load new or different application.

**Project is not available [0x008c000a]**

Module ID (decimal)	Error ID (decimal)
140: Application project manager	10
<b>Reaction</b> (Lenze setting in bold)	
<input type="checkbox"/> None <input type="checkbox"/> System fault <input checked="" type="checkbox"/> <b>Fault</b> <input type="checkbox"/> Trouble <input type="checkbox"/> Quick stop by trouble <input type="checkbox"/> Warning locked <input type="checkbox"/> Warning <input type="checkbox"/> Information	
<b>Cause</b>	<b>Remedy</b>
Application not available.	<ul style="list-style-type: none"> <li>• Download application with Engineer</li> <li>• Switch off controller and use a different memory module with an existing application.</li> </ul>

**Required licence missing [0x008c000b]**

Module ID (decimal)	Error ID (decimal)
140: Application project manager	11
<b>Reaction</b> (Lenze setting in bold)	
<input type="checkbox"/> None <input type="checkbox"/> System fault <input checked="" type="checkbox"/> <b>Fault</b> <input type="checkbox"/> Trouble <input type="checkbox"/> Quick stop by trouble <input type="checkbox"/> Warning locked <input type="checkbox"/> Warning <input type="checkbox"/> Information	
<b>Cause</b>	<b>Remedy</b>
Memory module could not be initialised.	Two possibilities: <ul style="list-style-type: none"> <li>• Use Engineer to download and activate an application suitable for the memory module.</li> <li>• Switch off controller and use memory module suitable for the application.</li> </ul>

**Application and device are incompatible [0x008c000c]**

Module ID (decimal)	Error ID (decimal)
140: Application project manager	12
<b>Reaction</b> (Lenze setting in bold)	
<input type="checkbox"/> None <input type="checkbox"/> System fault <input checked="" type="checkbox"/> <b>Fault</b> <input type="checkbox"/> Trouble <input type="checkbox"/> Quick stop by trouble <input type="checkbox"/> Warning locked <input type="checkbox"/> Warning <input type="checkbox"/> Information	
<b>Cause</b>	<b>Remedy</b>
Application is incompatible with the controller.	<ul style="list-style-type: none"> <li>• Download of an application suitable for the controller using Engineer.</li> <li>• Switch off controller and use a different memory module with suitable application.</li> </ul>

**MX11: Module is missing or incompatible [0x008c000d]**

Module ID (decimal)	Error ID (decimal)
140: Application project manager	13
<b>Reaction</b> (Lenze setting in bold)	
<input type="checkbox"/> None <input type="checkbox"/> System fault <input checked="" type="checkbox"/> <b>Fault</b> <input type="checkbox"/> Trouble <input type="checkbox"/> Quick stop by trouble <input type="checkbox"/> Warning locked <input type="checkbox"/> Warning <input type="checkbox"/> Information	
<b>Cause</b>	<b>Remedy</b>
Extension module in module slot MX11 is incompatible with the application.	Use extension module supported by the application.

**MX12: Module is missing or incompatible [0x008c000e]**

Module ID (decimal)	Error ID (decimal)
140: Application project manager	14
<b>Reaction</b> (Lenze setting in bold)	
<input type="checkbox"/> None <input type="checkbox"/> System fault <input checked="" type="checkbox"/> <b>Fault</b> <input type="checkbox"/> Trouble <input type="checkbox"/> Quick stop by trouble <input type="checkbox"/> Warning locked <input type="checkbox"/> Warning <input type="checkbox"/> Information	
<b>Cause</b>	<b>Remedy</b>
Extension module in module slot MX12 is incompatible with the application.	Use extension module supported by the application.

**MXI1: PROFIBUS module is missing or incompatible [0x008c000f]**

Module ID (decimal)	Error ID (decimal)
140: Application project manager	15
<b>Reaction</b> (Lenze setting in bold)	
Setting: <a href="#">C00615/2</a> ( <input checked="" type="checkbox"/> Adjustable response)	
<input checked="" type="checkbox"/> None <input type="checkbox"/> System fault <input checked="" type="checkbox"/> <b>Fault</b> <input type="checkbox"/> Trouble <input checked="" type="checkbox"/> Quick stop by trouble <input checked="" type="checkbox"/> Warning locked <input type="checkbox"/> Warning <input checked="" type="checkbox"/> Information	
<b>Cause</b>	<b>Remedy</b>
E94AYCPM communication module (PROFIBUS) in module slot MXI1 is incompatible with the application.	Use communication module supported by the application.

**MXI2: PROFIBUS module is missing or incompatible [0x008c0010]**

Module ID (decimal)	Error ID (decimal)
140: Application project manager	16
<b>Reaction</b> (Lenze setting in bold)	
Setting: <a href="#">C00615/3</a> ( <input checked="" type="checkbox"/> Adjustable response)	
<input checked="" type="checkbox"/> None <input type="checkbox"/> System fault <input checked="" type="checkbox"/> <b>Fault</b> <input type="checkbox"/> Trouble <input checked="" type="checkbox"/> Quick stop by trouble <input checked="" type="checkbox"/> Warning locked <input type="checkbox"/> Warning <input checked="" type="checkbox"/> Information	
<b>Cause</b>	<b>Remedy</b>
E94AYCPM communication module (PROFIBUS) in module slot MXI2 is incompatible with the application.	Use communication module supported by the application.

**MXI1: Ethernet module is missing or incompatible [0x008c0011]**

Module ID (decimal)	Error ID (decimal)
140: Application project manager	17
<b>Reaction</b> (Lenze setting in bold)	
Setting: <a href="#">C00615/2</a> ( <input checked="" type="checkbox"/> Adjustable response)	
<input checked="" type="checkbox"/> None <input type="checkbox"/> System fault <input checked="" type="checkbox"/> <b>Fault</b> <input type="checkbox"/> Trouble <input checked="" type="checkbox"/> Quick stop by trouble <input checked="" type="checkbox"/> Warning locked <input type="checkbox"/> Warning <input checked="" type="checkbox"/> Information	
<b>Cause</b>	<b>Remedy</b>
E94AYCEN communication module (Ethernet) in module slot MXI1 is incompatible with the application.	Use communication module supported by the application.

**MXI2: Ethernet module is missing or incompatible [0x008c0012]**

Module ID (decimal)	Error ID (decimal)
140: Application project manager	18
<b>Reaction</b> (Lenze setting in bold)	
Setting: <a href="#">C00615/3</a> ( <input checked="" type="checkbox"/> Adjustable response)	
<input checked="" type="checkbox"/> None <input type="checkbox"/> System fault <input checked="" type="checkbox"/> <b>Fault</b> <input type="checkbox"/> Trouble <input checked="" type="checkbox"/> Quick stop by trouble <input checked="" type="checkbox"/> Warning locked <input type="checkbox"/> Warning <input checked="" type="checkbox"/> Information	
<b>Cause</b>	<b>Remedy</b>
E94AYCEN communication module (Ethernet) in module slot MXI2 is incompatible with the application.	Use communication module supported by the application.

**MXI1: Digital frequency module is missing or incompatible [0x008c0013]**

Module ID (decimal)	Error ID (decimal)
140: Application project manager	19
<b>Reaction</b> (Lenze setting in bold)	
Setting: <a href="#">C00615/2</a> ( <input checked="" type="checkbox"/> Adjustable response)	
<input checked="" type="checkbox"/> None <input type="checkbox"/> System fault <input checked="" type="checkbox"/> <b>Fault</b> <input type="checkbox"/> Trouble <input checked="" type="checkbox"/> Quick stop by trouble <input checked="" type="checkbox"/> Warning locked <input type="checkbox"/> Warning <input checked="" type="checkbox"/> Information	
<b>Cause</b>	<b>Remedy</b>
Digital frequency extension module in module slot MXI1 is incompatible with the application.	Use extension module supported by the application.

**MXI2: Digital frequency module is missing or incompatible [0x008c0014]**

Module ID (decimal)	Error ID (decimal)
140: Application project manager	20
<b>Reaction</b> (Lenze setting in bold)	<b>Setting:</b> <a href="#">C00615/3</a> ( <input checked="" type="checkbox"/> Adjustable response)
<input checked="" type="checkbox"/> None <input type="checkbox"/> System fault <input checked="" type="checkbox"/> <b>Fault</b> <input type="checkbox"/> Trouble <input checked="" type="checkbox"/> Quick stop by trouble <input checked="" type="checkbox"/> Warning locked <input type="checkbox"/> Warning <input checked="" type="checkbox"/> Information	
Cause	Remedy
Digital frequency extension module in module slot MXI2 is incompatible with the application.	Use extension module supported by the application.

**MXI1: ICM module is missing or incompatible [0x008c0015]**

Module ID (decimal)	Error ID (decimal)
140: Application project manager	21
<b>Reaction</b> (Lenze setting in bold)	<b>Setting:</b> <a href="#">C00615/2</a> ( <input checked="" type="checkbox"/> Adjustable response)
<input checked="" type="checkbox"/> None <input type="checkbox"/> System fault <input checked="" type="checkbox"/> <b>Fault</b> <input type="checkbox"/> Trouble <input checked="" type="checkbox"/> Quick stop by trouble <input checked="" type="checkbox"/> Warning locked <input type="checkbox"/> Warning <input checked="" type="checkbox"/> Information	
Cause	Remedy
ICM extension module in module slot MXI1 is incompatible with the application.	Use extension module supported by the application.

**MXI2: ICM module is missing or incompatible [0x008c0016]**

Module ID (decimal)	Error ID (decimal)
140: Application project manager	22
<b>Reaction</b> (Lenze setting in bold)	<b>Setting:</b> <a href="#">C00615/3</a> ( <input checked="" type="checkbox"/> Adjustable response)
<input checked="" type="checkbox"/> None <input type="checkbox"/> System fault <input checked="" type="checkbox"/> <b>Fault</b> <input type="checkbox"/> Trouble <input checked="" type="checkbox"/> Quick stop by trouble <input checked="" type="checkbox"/> Warning locked <input type="checkbox"/> Warning <input checked="" type="checkbox"/> Information	
Cause	Remedy
ICM extension module in module slot MXI2 is incompatible with the application.	Use extension module supported by the application.

**MXI1: CAN module is missing or incompatible [0x008c0017]**

Module ID (decimal)	Error ID (decimal)
140: Application project manager	23
<b>Reaction</b> (Lenze setting in bold)	<b>Setting:</b> <a href="#">C00615/2</a> ( <input checked="" type="checkbox"/> Adjustable response)
<input checked="" type="checkbox"/> None <input type="checkbox"/> System fault <input checked="" type="checkbox"/> <b>Fault</b> <input type="checkbox"/> Trouble <input checked="" type="checkbox"/> Quick stop by trouble <input checked="" type="checkbox"/> Warning locked <input type="checkbox"/> Warning <input checked="" type="checkbox"/> Information	
Cause	Remedy
CANopen communication module in module slot MXI1 is incompatible with the application.	Use communication module supported by the application.

**MXI2: CAN module is missing or incompatible [0x008c0018]**

Module ID (decimal)	Error ID (decimal)
140: Application project manager	24
<b>Reaction</b> (Lenze setting in bold)	<b>Setting:</b> <a href="#">C00615/3</a> ( <input checked="" type="checkbox"/> Adjustable response)
<input checked="" type="checkbox"/> None <input type="checkbox"/> System fault <input checked="" type="checkbox"/> <b>Fault</b> <input type="checkbox"/> Trouble <input checked="" type="checkbox"/> Quick stop by trouble <input checked="" type="checkbox"/> Warning locked <input type="checkbox"/> Warning <input checked="" type="checkbox"/> Information	
Cause	Remedy
CANopen communication module in module slot MXI2 is incompatible with the application.	Use communication module supported by the application.

## ConnectTable active [0x008c001a]

Module ID (decimal)	Error ID (decimal)
140: Application project manager	26
<b>Reaction</b> (Lenze setting in bold)	
<input type="checkbox"/> None <input type="checkbox"/> System fault <input type="checkbox"/> Fault <input type="checkbox"/> Trouble <input type="checkbox"/> Quick stop by trouble <input type="checkbox"/> Warning locked <input type="checkbox"/> Warning <input checked="" type="checkbox"/> <b>Information</b>	
<b>Cause</b>	<b>Remedy</b>
The application is provided with a so-called connection table, i. e. connections can be altered "online" in the function block editor without having to carry out a new complete download.	- (Information only)

## Internal error (CRC application) [0x008c001d]

Module ID (decimal)	Error ID (decimal)
140: Application project manager	29
<b>Reaction</b> (Lenze setting in bold)	
<input type="checkbox"/> None <input type="checkbox"/> System fault <input checked="" type="checkbox"/> <b>Fault</b> <input type="checkbox"/> Trouble <input type="checkbox"/> Quick stop by trouble <input type="checkbox"/> Warning locked <input type="checkbox"/> Warning <input type="checkbox"/> Information	
<b>Cause</b>	<b>Remedy</b>
<ul style="list-style-type: none"> <li>• The checksum of the application is faulty.</li> <li>• Files required to run the application are missing.</li> <li>• The supply voltage failed before the entire parameter set could be saved.</li> </ul>	Transmit the application to the controller again.

## Storage capacity for user parameters exceeded [0x008c001e]

Module ID (decimal)	Error ID (decimal)
140: Application project manager	30
<b>Reaction</b> (Lenze setting in bold)	
<input type="checkbox"/> None <input type="checkbox"/> System fault <input checked="" type="checkbox"/> <b>Fault</b> <input type="checkbox"/> Trouble <input type="checkbox"/> Quick stop by trouble <input type="checkbox"/> Warning locked <input type="checkbox"/> Warning <input type="checkbox"/> Information	
<b>Cause</b>	<b>Remedy</b>
Due to the creation of too many user parameters within the application, the storage capacity available on the memory module has been exceeded. User parameters are produced directly by manual creation or indirectly by the insertion of function blocks.	<ul style="list-style-type: none"> <li>• Use an MM4xx memory module instead of the MM3xx type (approx. twice the storage capacity).</li> <li>• Remove unnecessary, manually created user parameters from the application.</li> <li>• Remove unnecessary function blocks from the application.</li> <li>• Recompile the application and download it again.</li> <li>• Acknowledge the error.</li> </ul> Then the current utilisation of the memory can be assessed using code <a href="#">C02112</a> . If 100 % is displayed, this corresponds to the maximum utilisation for an executable application.

## Parameter set faulty [0x00900000]

Module ID (decimal)	Error ID (decimal)
144: Parameter manager	0
<b>Reaction</b> (Lenze setting in bold)	
<input type="checkbox"/> None <input type="checkbox"/> System fault <input checked="" type="checkbox"/> <b>Fault</b> <input type="checkbox"/> Trouble <input type="checkbox"/> Quick stop by trouble <input type="checkbox"/> Warning locked <input type="checkbox"/> Warning <input type="checkbox"/> Information	
<b>Cause</b>	<b>Remedy</b>
Parameter set is invalid.	Transfer parameter set from Engineer to the controller and save with <a href="#">C00002</a> ="11".

**Lenze setting loaded [0x00900001]**

Module ID (decimal)	Error ID (decimal)
144: Parameter manager	1
<b>Reaction (Lenze setting in bold)</b>	
<input type="checkbox"/> None <input type="checkbox"/> System fault <input type="checkbox"/> Fault <input type="checkbox"/> Trouble <input type="checkbox"/> Quick stop by trouble <input type="checkbox"/> Warning locked <input type="checkbox"/> Warning <input checked="" type="checkbox"/> <b>Information</b>	
<b>Cause</b>	<b>Remedy</b>
Lenze setting has been loaded.	- (Information only)

**Parameter set saved [0x00900002]**

Module ID (decimal)	Error ID (decimal)
144: Parameter manager	2
<b>Reaction (Lenze setting in bold)</b>	
<input type="checkbox"/> None <input type="checkbox"/> System fault <input type="checkbox"/> Fault <input type="checkbox"/> Trouble <input type="checkbox"/> Quick stop by trouble <input type="checkbox"/> Warning locked <input type="checkbox"/> Warning <input checked="" type="checkbox"/> <b>Information</b>	
<b>Cause</b>	<b>Remedy</b>
Parameter set has been saved.	- (Information only)

**Parameter set loaded [0x00900003]**

Module ID (decimal)	Error ID (decimal)
144: Parameter manager	3
<b>Reaction (Lenze setting in bold)</b>	
<input type="checkbox"/> None <input type="checkbox"/> System fault <input type="checkbox"/> Fault <input type="checkbox"/> Trouble <input type="checkbox"/> Quick stop by trouble <input type="checkbox"/> Warning locked <input type="checkbox"/> Warning <input checked="" type="checkbox"/> <b>Information</b>	
<b>Cause</b>	<b>Remedy</b>
Parameter set has been loaded.	- (Information only)

**Loading of Lenze setting failed [0x00900004]**

Module ID (decimal)	Error ID (decimal)
144: Parameter manager	4
<b>Reaction (Lenze setting in bold)</b>	
<input type="checkbox"/> None <input type="checkbox"/> System fault <input checked="" type="checkbox"/> <b>Fault</b> <input type="checkbox"/> Trouble <input type="checkbox"/> Quick stop by trouble <input type="checkbox"/> Warning locked <input type="checkbox"/> Warning <input type="checkbox"/> Information	
<b>Cause</b>	<b>Remedy</b>
Lenze setting of a parameter is not within the valid limits.	Eliminate error in the application and retransfer application to controller.

**Parameter set restored [0x00900005]**

Module ID (decimal)	Error ID (decimal)
144: Parameter manager	5
<b>Reaction (Lenze setting in bold)</b>	
<input type="checkbox"/> None <input type="checkbox"/> System fault <input checked="" type="checkbox"/> <b>Fault</b> <input type="checkbox"/> Trouble <input type="checkbox"/> Quick stop by trouble <input type="checkbox"/> Warning locked <input type="checkbox"/> Warning <input type="checkbox"/> Information	
<b>Cause</b>	<b>Remedy</b>
An error has occurred while loading the selected parameter set.	Transfer parameter set from Engineer to the controller and save with <code>C00002="11"</code> .

## Saving of parameters failed [0x00900006]

Module ID (decimal)	Error ID (decimal)
144: Parameter manager	6
<b>Reaction</b> (Lenze setting in bold)	
<input type="checkbox"/> None <input type="checkbox"/> System fault <input checked="" type="checkbox"/> <b>Fault</b> <input type="checkbox"/> Trouble <input type="checkbox"/> Quick stop by trouble <input type="checkbox"/> Warning locked <input type="checkbox"/> Warning <input type="checkbox"/> Information	
<b>Cause</b>	<b>Remedy</b>
An error has occurred while saving the current parameter set.	Use a different memory module.

## Parameter set: Version conflict [0x00900007]

Module ID (decimal)	Error ID (decimal)
144: Parameter manager	7
<b>Reaction</b> (Lenze setting in bold)	
<input type="checkbox"/> None <input type="checkbox"/> System fault <input checked="" type="checkbox"/> <b>Fault</b> <input type="checkbox"/> Trouble <input type="checkbox"/> Quick stop by trouble <input type="checkbox"/> Warning locked <input type="checkbox"/> Warning <input type="checkbox"/> Information	
<b>Cause</b>	<b>Remedy</b>
The parameter set version on the memory module is not compatible with the firmware of the controller.	Transfer parameter set from Engineer to the controller and save with <code>C00002="11"</code> .

## Code number duplicated [0x00900008]

Module ID (decimal)	Error ID (decimal)
144: Parameter manager	8
<b>Reaction</b> (Lenze setting in bold)	
<input type="checkbox"/> None <input type="checkbox"/> System fault <input type="checkbox"/> Fault <input type="checkbox"/> Trouble <input type="checkbox"/> Quick stop by trouble <input checked="" type="checkbox"/> <b>Warning locked</b> <input type="checkbox"/> Warning <input type="checkbox"/> Information	
<b>Cause</b>	<b>Remedy</b>
Code number of the operating system has been assigned to the application.	Eliminate error in the application and retransfer application to controller.

## Parameter set: Type of standard device has been changed [0x00900009]

Module ID (decimal)	Error ID (decimal)
144: Parameter manager	9
<b>Reaction</b> (Lenze setting in bold)	
<input type="checkbox"/> None <input type="checkbox"/> System fault <input type="checkbox"/> Fault <input type="checkbox"/> Trouble <input type="checkbox"/> Quick stop by trouble <input type="checkbox"/> Warning locked <input type="checkbox"/> Warning <input checked="" type="checkbox"/> <b>Information</b>	
<b>Cause</b>	<b>Remedy</b>
The firmware has loaded a parameter set the type code of which does not correspond to the type code of the controller.	Load a suitable parameter set.



**No parameters for module in MXI1 [0x0090000a]**

Module ID (decimal)	Error ID (decimal)
144: Parameter manager	10
<b>Reaction</b> (Lenze setting in bold)	
Setting: <a href="#">C00615/2</a> ( <input checked="" type="checkbox"/> Adjustable response)	
<input checked="" type="checkbox"/> None <input type="checkbox"/> System fault <input checked="" type="checkbox"/> <b>Fault</b> <input type="checkbox"/> Trouble <input checked="" type="checkbox"/> Quick stop by trouble <input checked="" type="checkbox"/> Warning locked <input type="checkbox"/> Warning <input checked="" type="checkbox"/> Information	
<b>Cause</b>	
The parameter set contains no parameters for the module inserted in MXI1.	<b>Remedy</b>
	Integrate the module inserted in MXI1 into the Engineer project and then retransmit the parameter set to the controller.

**No parameters for module in MXI2 [0x0090000b]**

Module ID (decimal)	Error ID (decimal)
144: Parameter manager	11
<b>Reaction</b> (Lenze setting in bold)	
Setting: <a href="#">C00615/3</a> ( <input checked="" type="checkbox"/> Adjustable response)	
<input checked="" type="checkbox"/> None <input type="checkbox"/> System fault <input checked="" type="checkbox"/> <b>Fault</b> <input type="checkbox"/> Trouble <input checked="" type="checkbox"/> Quick stop by trouble <input checked="" type="checkbox"/> Warning locked <input type="checkbox"/> Warning <input checked="" type="checkbox"/> Information	
<b>Cause</b>	
The parameter set contains no parameters for the module inserted in MXI2.	<b>Remedy</b>
	Integrate the module inserted in MXI2 into the Engineer project and then retransmit the parameter set to the controller.

**Disconnection in the case of par. storage [0x0090000c]**

Module ID (decimal)	Error ID (decimal)
144: Parameter manager	12
<b>Reaction</b> (Lenze setting in bold)	
<input type="checkbox"/> None <input type="checkbox"/> System fault <input checked="" type="checkbox"/> <b>Fault</b> <input type="checkbox"/> Trouble <input type="checkbox"/> Quick stop by trouble <input type="checkbox"/> Warning locked <input type="checkbox"/> Warning <input type="checkbox"/> Information	
<b>Cause</b>	
The supply voltage has failed before the saving of the parameter set could be completed. In the case of a device replacement/firmware update, the parameter set can no longer be established automatically.	<b>Remedy</b>
	Save the start parameters again, and in doing this, ensure that the supply voltage is applied until the saving process has been completed. Afterwards acknowledge the error message with "Reset error".

**Mains voltage is switched on [0x00910000]**

Module ID (decimal)	Error ID (decimal)
145: Lenze runtime system	0
<b>Reaction</b> (Lenze setting in bold)	
<input type="checkbox"/> None <input type="checkbox"/> System fault <input type="checkbox"/> Fault <input type="checkbox"/> Trouble <input type="checkbox"/> Quick stop by trouble <input type="checkbox"/> Warning locked <input type="checkbox"/> Warning <input checked="" type="checkbox"/> <b>Information</b>	
<b>Cause</b>	
Mains voltage has been switched on.	<b>Remedy</b>
	- (Information only)

**Mains voltage is switched off [0x00910001]**

Module ID (decimal)	Error ID (decimal)
145: Lenze runtime system	1
<b>Reaction</b> (Lenze setting in bold)	
<input type="checkbox"/> None <input type="checkbox"/> System fault <input type="checkbox"/> Fault <input type="checkbox"/> Trouble <input type="checkbox"/> Quick stop by trouble <input type="checkbox"/> Warning locked <input type="checkbox"/> Warning <input checked="" type="checkbox"/> <b>Information</b>	
<b>Cause</b>	<b>Remedy</b>
Mains voltage has been switched off.	- (Information only)

**No heartbeat signal detected [0x00910002]**

Module ID (decimal)	Error ID (decimal)
145: Lenze runtime system	2
<b>Reaction</b> (Lenze setting in bold)	
<input type="checkbox"/> None <input checked="" type="checkbox"/> <b>System fault</b> <input type="checkbox"/> Fault <input type="checkbox"/> Trouble <input type="checkbox"/> Quick stop by trouble <input type="checkbox"/> Warning locked <input type="checkbox"/> Warning <input type="checkbox"/> Information	
<b>Cause</b>	<b>Remedy</b>
Internal error	If the error occurs frequently, please contact Lenze.

**Heartbeat not periodic [0x00910003]**

Module ID (decimal)	Error ID (decimal)
145: Lenze runtime system	3
<b>Reaction</b> (Lenze setting in bold)	
<input type="checkbox"/> None <input checked="" type="checkbox"/> <b>System fault</b> <input type="checkbox"/> Fault <input type="checkbox"/> Trouble <input type="checkbox"/> Quick stop by trouble <input type="checkbox"/> Warning locked <input type="checkbox"/> Warning <input type="checkbox"/> Information	
<b>Cause</b>	<b>Remedy</b>
Internal error	If the error occurs frequently, please contact Lenze.

**Internal error: See C00180 [0x00910004]**

Module ID (decimal)	Error ID (decimal)
145: Lenze runtime system	4
<b>Reaction</b> (Lenze setting in bold)	
<input type="checkbox"/> None <input checked="" type="checkbox"/> <b>System fault</b> <input type="checkbox"/> Fault <input type="checkbox"/> Trouble <input type="checkbox"/> Quick stop by trouble <input type="checkbox"/> Warning locked <input type="checkbox"/> Warning <input type="checkbox"/> Information	
<b>Cause</b>	<b>Remedy</b>
Internal error	If the error occurs frequently, please contact Lenze.

**Internal error: See C00180 [0x00910005]**

Module ID (decimal)	Error ID (decimal)
145: Lenze runtime system	5
<b>Reaction</b> (Lenze setting in bold)	
<input type="checkbox"/> None <input checked="" type="checkbox"/> <b>System fault</b> <input type="checkbox"/> Fault <input type="checkbox"/> Trouble <input type="checkbox"/> Quick stop by trouble <input type="checkbox"/> Warning locked <input type="checkbox"/> Warning <input type="checkbox"/> Information	
<b>Cause</b>	<b>Remedy</b>
Internal error	Please contact Lenze.

## Internal error: See C00180 [0x00910006]

Module ID (decimal)	Error ID (decimal)
145: Lenze runtime system	6
<b>Reaction</b> (Lenze setting in bold)	
<input type="checkbox"/> None <input checked="" type="checkbox"/> <b>System fault</b> <input type="checkbox"/> Fault <input type="checkbox"/> Trouble <input type="checkbox"/> Quick stop by trouble <input type="checkbox"/> Warning locked <input type="checkbox"/> Warning <input type="checkbox"/> Information	
<b>Cause</b>	<b>Remedy</b>
Divisor of division was "0".	Replace application.

## Internal error: See C00180 [0x00910008]

Module ID (decimal)	Error ID (decimal)
145: Lenze runtime system	8
<b>Reaction</b> (Lenze setting in bold)	
<input type="checkbox"/> None <input type="checkbox"/> System fault <input checked="" type="checkbox"/> <b>Fault</b> <input type="checkbox"/> Trouble <input type="checkbox"/> Quick stop by trouble <input type="checkbox"/> Warning locked <input type="checkbox"/> Warning <input type="checkbox"/> Information	
<b>Cause</b>	<b>Remedy</b>
Internal error	If the error occurs frequently, please contact Lenze.

## Internal error: See C00180 [0x00910009]

Module ID (decimal)	Error ID (decimal)
145: Lenze runtime system	9
<b>Reaction</b> (Lenze setting in bold)	
<input type="checkbox"/> None <input type="checkbox"/> System fault <input checked="" type="checkbox"/> <b>Fault</b> <input type="checkbox"/> Trouble <input type="checkbox"/> Quick stop by trouble <input type="checkbox"/> Warning locked <input type="checkbox"/> Warning <input type="checkbox"/> Information	
<b>Cause</b>	<b>Remedy</b>
Internal error	If the error occurs frequently, please contact Lenze.

## System task 1: Task overflow [0x0091000a]

Module ID (decimal)	Error ID (decimal)
145: Lenze runtime system	10
<b>Reaction</b> (Lenze setting in bold)	
<input type="checkbox"/> None <input checked="" type="checkbox"/> <b>System fault</b> <input type="checkbox"/> Fault <input type="checkbox"/> Trouble <input type="checkbox"/> Quick stop by trouble <input type="checkbox"/> Warning locked <input type="checkbox"/> Warning <input type="checkbox"/> Information	
<b>Cause</b>	<b>Remedy</b>
System overload.	Please contact Lenze.

## System task 2: Task overflow [0x0091000b]

Module ID (decimal)	Error ID (decimal)
145: Lenze runtime system	11
<b>Reaction</b> (Lenze setting in bold)	
<input type="checkbox"/> None <input type="checkbox"/> System fault <input type="checkbox"/> Fault <input type="checkbox"/> Trouble <input type="checkbox"/> Quick stop by trouble <input type="checkbox"/> Warning locked <input type="checkbox"/> Warning <input checked="" type="checkbox"/> <b>Information</b>	
<b>Cause</b>	<b>Remedy</b>
System overload.	Please contact Lenze.

## System task 3: Task overflow [0x0091000c]

Module ID (decimal)	Error ID (decimal)
145: Lenze runtime system	12
<b>Reaction</b> (Lenze setting in bold)	
<input type="checkbox"/> None <input checked="" type="checkbox"/> <b>System fault</b> <input type="checkbox"/> Fault <input type="checkbox"/> Trouble <input type="checkbox"/> Quick stop by trouble <input type="checkbox"/> Warning locked <input type="checkbox"/> Warning <input type="checkbox"/> Information	
<b>Cause</b>	<b>Remedy</b>
System overload.	Please contact Lenze.

## System task: Task overflow [0x0091000d]

Module ID (decimal)	Error ID (decimal)
145: Lenze runtime system	13
<b>Reaction</b> (Lenze setting in bold)	
<input type="checkbox"/> None <input type="checkbox"/> System fault <input checked="" type="checkbox"/> <b>Fault</b> <input type="checkbox"/> Trouble <input type="checkbox"/> Quick stop by trouble <input type="checkbox"/> Warning locked <input type="checkbox"/> Warning <input type="checkbox"/> Information	
<b>Cause</b>	<b>Remedy</b>
System overload.	Please contact Lenze.

## Communication task: Standstill &gt; 3 s [0x0091000e]

Module ID (decimal)	Error ID (decimal)
145: Lenze runtime system	14
<b>Reaction</b> (Lenze setting in bold)	
Setting: <a href="#">C01230</a> ( <input checked="" type="checkbox"/> Adjustable response)	
<input checked="" type="checkbox"/> None <input type="checkbox"/> System fault <input checked="" type="checkbox"/> <b>Fault</b> <input checked="" type="checkbox"/> Trouble <input checked="" type="checkbox"/> Quick stop by trouble <input checked="" type="checkbox"/> Warning locked <input checked="" type="checkbox"/> Warning <input checked="" type="checkbox"/> Information	
<b>Cause</b>	<b>Remedy</b>
Service data communication within the system (SDO communication of all bus systems connected) has caused an overload of service data processing. Due to this, the monitoring interval of the processing task has been violated. PDO communication is not affected by this overload.	Reduce system load. <ul style="list-style-type: none"> <li>• Reduce the data and communication volume on the buses. Processing will restart automatically when the overload has been eliminated.</li> </ul> For systems frequently affected by this type of overload, the error response can be changed to warning via code <a href="#">C01230</a> in order to increase the drive availability.

## Cyclic task: Standstill &gt; 60 s [0x0091000f]

Module ID (decimal)	Error ID (decimal)
145: Lenze runtime system	15
<b>Reaction</b> (Lenze setting in bold)	
<input type="checkbox"/> None <input type="checkbox"/> System fault <input type="checkbox"/> Fault <input type="checkbox"/> Trouble <input type="checkbox"/> Quick stop by trouble <input type="checkbox"/> Warning locked <input type="checkbox"/> Warning <input checked="" type="checkbox"/> <b>Information</b>	
<b>Cause</b>	<b>Remedy</b>
System overload or CRC check task crash.	Reduce system load. <ul style="list-style-type: none"> <li>• This is possible in the application or data transfer of the communication interfaces.</li> </ul>

**Position value faulty [0x00910010]**

Module ID (decimal)	Error ID (decimal)
145: Lenze runtime system	16
<b>Reaction</b> (Lenze setting in bold)	
<input type="checkbox"/> None <input type="checkbox"/> System fault <input checked="" type="checkbox"/> <b>Fault</b> <input type="checkbox"/> Trouble <input type="checkbox"/> Quick stop by trouble <input type="checkbox"/> Warning locked <input type="checkbox"/> Warning <input type="checkbox"/> Information	
<b>Cause</b>	<b>Remedy</b>
Internal error	If the error occurs frequently, please contact Lenze.

**Error during initialisation [0x00910011]**

Module ID (decimal)	Error ID (decimal)
145: Lenze runtime system	17
<b>Reaction</b> (Lenze setting in bold)	
<input type="checkbox"/> None <input checked="" type="checkbox"/> <b>System fault</b> <input type="checkbox"/> Fault <input type="checkbox"/> Trouble <input type="checkbox"/> Quick stop by trouble <input type="checkbox"/> Warning locked <input type="checkbox"/> Warning <input type="checkbox"/> Information	
<b>Cause</b>	<b>Remedy</b>
Internal error	If the error occurs frequently, please contact Lenze.

**Block function in wrong MEC task [0x00910012]**

Module ID (decimal)	Error ID (decimal)
145: Lenze runtime system	18
<b>Reaction</b> (Lenze setting in bold)	
<input type="checkbox"/> None <input type="checkbox"/> System fault <input checked="" type="checkbox"/> <b>Fault</b> <input type="checkbox"/> Trouble <input type="checkbox"/> Quick stop by trouble <input type="checkbox"/> Warning locked <input type="checkbox"/> Warning <input type="checkbox"/> Information	
<b>Cause</b>	<b>Remedy</b>
Internal error	If the error occurs frequently, please contact Lenze.

**Safety module: Incompatible with setting in C00214 [0x00920000]**

Module ID (decimal)	Error ID (decimal)
146: Interface to the safety module	0
<b>Reaction</b> (Lenze setting in bold)	
<input type="checkbox"/> None <input checked="" type="checkbox"/> <b>System fault</b> <input type="checkbox"/> Fault <input type="checkbox"/> Trouble <input type="checkbox"/> Quick stop by trouble <input type="checkbox"/> Warning locked <input type="checkbox"/> Warning <input type="checkbox"/> Information	
<b>Cause</b>	<b>Remedy</b>
The controller has detected a safety module which does not match the setting under <a href="#">C00214</a> .	Change setting under <a href="#">C00214</a> or use a suitable safety module. <ul style="list-style-type: none"> <li>• Afterwards mains switching is required.</li> </ul>

**Communication with safety module interrupted [0x00920001]**

Module ID (decimal)	Error ID (decimal)
146: Interface to the safety module	1
<b>Reaction</b> (Lenze setting in bold)	
<input type="checkbox"/> None <input type="checkbox"/> System fault <input type="checkbox"/> Fault <input type="checkbox"/> Trouble <input type="checkbox"/> Quick stop by trouble <input type="checkbox"/> Warning locked <input type="checkbox"/> Warning <input checked="" type="checkbox"/> <b>Information</b>	
<b>Cause</b>	<b>Remedy</b>
It is not possible to establish communication between the controller and safety module.	<ul style="list-style-type: none"> <li>• Switch off the controller, plug in safety module correctly and switch on the controller again.</li> <li>• If the problem occurs again, replace the safety module.</li> </ul>

**DFIN (MXI1): Track error A-/A [0x00990000]**

Module ID (decimal)	Error ID (decimal)
153: Extension module - digital frequency in MXI1	0
<b>Reaction</b> (Lenze setting in bold)	
Setting: <a href="#">C13040</a> ( <input checked="" type="checkbox"/> Adjustable response)	
<input checked="" type="checkbox"/> None <input type="checkbox"/> System fault <input checked="" type="checkbox"/> <b>Fault</b> <input checked="" type="checkbox"/> Trouble <input checked="" type="checkbox"/> Quick stop by trouble <input checked="" type="checkbox"/> Warning locked <input checked="" type="checkbox"/> Warning <input checked="" type="checkbox"/> Information	
<b>Cause</b>	
Digital frequency extension module in MXI1: Interruption (open circuit) of the signal cable for track A.	<b>Remedy</b> <ul style="list-style-type: none"> <li>• Check signal cable for track A.</li> <li>• Check encoder.</li> </ul>

**DFIN (MXI1): Track error B-/B [0x00990001]**

Module ID (decimal)	Error ID (decimal)
153: Extension module - digital frequency in MXI1	1
<b>Reaction</b> (Lenze setting in bold)	
Setting: <a href="#">C13040</a> ( <input checked="" type="checkbox"/> Adjustable response)	
<input checked="" type="checkbox"/> None <input type="checkbox"/> System fault <input checked="" type="checkbox"/> <b>Fault</b> <input checked="" type="checkbox"/> Trouble <input checked="" type="checkbox"/> Quick stop by trouble <input checked="" type="checkbox"/> Warning locked <input checked="" type="checkbox"/> Warning <input checked="" type="checkbox"/> Information	
<b>Cause</b>	
Digital frequency extension module in MXI1: Interruption (open circuit) of the signal cable for track B.	<b>Remedy</b> <ul style="list-style-type: none"> <li>• Check signal cable for track B.</li> <li>• Check encoder.</li> </ul>

**DFIN (MXI1): Track error Z-/Z [0x00990002]**

Module ID (decimal)	Error ID (decimal)
153: Extension module - digital frequency in MXI1	2
<b>Reaction</b> (Lenze setting in bold)	
Setting: <a href="#">C13040</a> ( <input checked="" type="checkbox"/> Adjustable response)	
<input checked="" type="checkbox"/> None <input type="checkbox"/> System fault <input checked="" type="checkbox"/> <b>Fault</b> <input checked="" type="checkbox"/> Trouble <input checked="" type="checkbox"/> Quick stop by trouble <input checked="" type="checkbox"/> Warning locked <input checked="" type="checkbox"/> Warning <input checked="" type="checkbox"/> Information	
<b>Cause</b>	
Digital frequency extension module in MXI1: Interruption (open circuit) of the signal cable for track Z.	<b>Remedy</b> <ul style="list-style-type: none"> <li>• Check signal cable for track Z.</li> <li>• Check encoder.</li> </ul>

**DFIN (MXI1): Signal error enable/lamp control [0x00990003]**

Module ID (decimal)	Error ID (decimal)
153: Extension module - digital frequency in MXI1	3
<b>Reaction</b> (Lenze setting in bold)	
Setting: <a href="#">C13041</a> ( <input checked="" type="checkbox"/> Adjustable response)	
<input checked="" type="checkbox"/> None <input type="checkbox"/> System fault <input checked="" type="checkbox"/> <b>Fault</b> <input checked="" type="checkbox"/> Trouble <input checked="" type="checkbox"/> Quick stop by trouble <input checked="" type="checkbox"/> Warning locked <input checked="" type="checkbox"/> <b>Warning</b> <input checked="" type="checkbox"/> Information	
<b>Cause</b>	
Digital frequency extension module in MXI1: Interruption (open circuit) of the signal cable for the "Enable" signal or no "Enable" signal available.	<b>Remedy</b> <ul style="list-style-type: none"> <li>• Check signal cable for "Enable" signal.</li> <li>• Check encoder.</li> </ul>

**DFIN (MXI1): Supply cannot be corrected anymore [0x00990004]**

Module ID (decimal)	Error ID (decimal)
153: Extension module - digital frequency in MXI1	4
<b>Reaction</b> (Lenze setting in bold)	
Setting: <a href="#">C13042</a> ( <input checked="" type="checkbox"/> Adjustable response)	
<input checked="" type="checkbox"/> None <input type="checkbox"/> System fault <input checked="" type="checkbox"/> Fault <input checked="" type="checkbox"/> Trouble <input checked="" type="checkbox"/> Quick stop by trouble <input checked="" type="checkbox"/> Warning locked <input checked="" type="checkbox"/> <b>Warning</b> <input checked="" type="checkbox"/> Information	
<b>Cause</b>	
Digital frequency extension module in MXI1: The encoder voltage controlled by the digital frequency input has reached the voltage limit.	<b>Remedy</b>
	Check encoder.

**DFOUT (MXI1): Maximum frequency reached [0x00990005]**

Module ID (decimal)	Error ID (decimal)
153: Extension module - digital frequency in MXI1	5
<b>Reaction</b> (Lenze setting in bold)	
Setting: <a href="#">C13080</a> ( <input checked="" type="checkbox"/> Adjustable response)	
<input checked="" type="checkbox"/> None <input type="checkbox"/> System fault <input checked="" type="checkbox"/> Fault <input checked="" type="checkbox"/> Trouble <input checked="" type="checkbox"/> Quick stop by trouble <input checked="" type="checkbox"/> Warning locked <input checked="" type="checkbox"/> <b>Warning</b> <input checked="" type="checkbox"/> Information	
<b>Cause</b>	
Digital frequency extension module in MXI1: Limit frequency at the digital frequency output reached. <ul style="list-style-type: none"> <li>The digital frequency has reached the limit value set in <a href="#">C013053</a>.</li> </ul>	<b>Remedy</b>
	Check limit value set.

**CAN module (MXI1): Bus off [0x009d0000]**

Module ID (decimal)	Error ID (decimal)
157: CAN module in MXI1: CAN dispatcher	0
<b>Reaction</b> (Lenze setting in bold)	
Setting: <a href="#">C13595</a> ( <input checked="" type="checkbox"/> Adjustable response)	
<input checked="" type="checkbox"/> None <input type="checkbox"/> System fault <input checked="" type="checkbox"/> Fault <input checked="" type="checkbox"/> Trouble <input checked="" type="checkbox"/> Quick stop by trouble <input checked="" type="checkbox"/> Warning locked <input checked="" type="checkbox"/> Warning <input checked="" type="checkbox"/> <b>Information</b>	
<b>Cause</b>	
CANopen communication module in MXI1: "Bus-off" state <ul style="list-style-type: none"> <li>Received too many faulty telegrams.</li> <li>Defective cable (e.g. loose contact).</li> <li>Two nodes with the same ID.</li> </ul>	<b>Remedy</b>
	<ul style="list-style-type: none"> <li>Remove fault (e.g. EMC).</li> <li>Remove loose contact, screw down adapter.</li> <li>Assign different IDs to nodes.</li> </ul>

**CAN module (MXI1): Invalid node address 0 [0x009d0001]**

Module ID (decimal)	Error ID (decimal)
157: CAN module in MXI1: CAN dispatcher	1
<b>Reaction</b> (Lenze setting in bold)	
<input type="checkbox"/> None <input type="checkbox"/> System fault <input type="checkbox"/> Fault <input type="checkbox"/> Trouble <input type="checkbox"/> Quick stop by trouble <input type="checkbox"/> Warning locked <input checked="" type="checkbox"/> <b>Warning</b> <input type="checkbox"/> Information	
<b>Cause</b>	
CANopen communication module in MXI1: Initialisation error <ul style="list-style-type: none"> <li>The hardware allocation of the node address was selected via DIP switches, and the DIP switches of the node address are all on zero.</li> </ul> <b>Note:</b> Instead of the impermissible node address 0, node address 1 is used.	<b>Remedy</b>
	<ul style="list-style-type: none"> <li>Set a non-zero node address by means of the DIP switches and then switch mains.</li> <li>Activation of the software allocation of the node number by switching over DIP switch 2, then switch mains.</li> </ul>

## CAN module (MXI1): Basic configuration invalid [0x009d0002]

Module ID (decimal)	Error ID (decimal)
157: CAN module in MXI1: CAN dispatcher	2
<b>Reaction</b> (Lenze setting in bold)	
<input type="checkbox"/> None <input type="checkbox"/> System fault <input type="checkbox"/> Fault <input type="checkbox"/> Trouble <input type="checkbox"/> Quick stop by trouble <input checked="" type="checkbox"/> <b>Warning locked</b> <input type="checkbox"/> Warning <input type="checkbox"/> Information	
<b>Cause</b>	<b>Remedy</b>
CANopen communication module in MXI1: Configuration error <ul style="list-style-type: none"> <li>Faulty download of an Engineer or PLC Designer project</li> <li>Invalid CAN settings according to DS301V402 in the Engineer or PLC Designer.</li> </ul>	<ul style="list-style-type: none"> <li>Repeat download</li> <li>Correct CAN settings in the project and regenerate project.</li> </ul>

## CAN module (MXI1): Heartbeat error index 1 ... 32 [0x009e0000 ... 0x009e001f]

Module ID (decimal)	Error ID (decimal)
158: CAN module in MXI1: CAN-NMT handler	0 ... 31
<b>Reaction</b> (Lenze setting in bold)	
Setting: <a href="#">C13613/1...32</a> ( <input checked="" type="checkbox"/> Adjustable response)	
<input checked="" type="checkbox"/> <b>None</b> <input type="checkbox"/> System fault <input checked="" type="checkbox"/> Fault <input checked="" type="checkbox"/> Trouble <input checked="" type="checkbox"/> Quick stop by trouble <input checked="" type="checkbox"/> Warning locked <input checked="" type="checkbox"/> Warning <input checked="" type="checkbox"/> Information	
<b>Cause</b>	<b>Remedy</b>
CANopen communication module in MXI1: Cyclic node monitoring <ul style="list-style-type: none"> <li>Node station has not received a heartbeat telegram from node 1 ... 32 within the defined time.</li> </ul>	<ul style="list-style-type: none"> <li>Reactivate CAN node by mains switching, restart of the controller (<a href="#">C00002</a>="11000") or CAN reset node.</li> <li>Select a different heartbeat producer monitoring time or switch off monitoring and reset locked error status, if necessary.</li> </ul> Tip: Save the current parameter set before mains switching and restart of the controller ( <a href="#">C00002</a> ="11").

## CAN module (MXI1): Lifeguarding error [0x009e0020]

Module ID (decimal)	Error ID (decimal)
158: CAN module in MXI1: CAN-NMT handler	32
<b>Reaction</b> (Lenze setting in bold)	
Setting: <a href="#">C13614</a> ( <input checked="" type="checkbox"/> Adjustable response)	
<input checked="" type="checkbox"/> <b>None</b> <input type="checkbox"/> System fault <input checked="" type="checkbox"/> Fault <input checked="" type="checkbox"/> Trouble <input checked="" type="checkbox"/> Quick stop by trouble <input checked="" type="checkbox"/> Warning locked <input checked="" type="checkbox"/> Warning <input checked="" type="checkbox"/> Information	
<b>Cause</b>	<b>Remedy</b>
CANopen communication module in MXI1: Cyclic node monitoring <ul style="list-style-type: none"> <li>Slave response: Maximum time between two node guarding telegrams (remote transmission request telegram) from the master has been exceeded.</li> </ul>	Select a different Lifeguarding monitoring time or switch off monitoring.



## CAN module (MXI1): Faulty NMT slave configuration [0x009e0021]

Module ID (decimal)	Error ID (decimal)
158: CAN module in MXI1: CAN-NMT handler	33
<b>Reaction</b> (Lenze setting in bold)	
<input type="checkbox"/> None <input type="checkbox"/> System fault <input type="checkbox"/> Fault <input type="checkbox"/> Trouble <input type="checkbox"/> Quick stop by trouble <input checked="" type="checkbox"/> <b>Warning locked</b> <input type="checkbox"/> Warning <input type="checkbox"/> Information	
<b>Cause</b>	<b>Remedy</b>
CANopen communication module in MXI1: A configuration error has occurred in the network management of the CAN slave. <ul style="list-style-type: none"> <li>• Faulty download of an Engineer or PLC Designer project</li> <li>• Invalid CAN settings according to DS301V402 in the Engineer or PLC Designer.</li> <li>• Incorrect parameterisation of node guarding or heartbeat.</li> </ul>	<ul style="list-style-type: none"> <li>• Repeat download</li> <li>• Correct CAN settings in the project and regenerate project.</li> </ul>

## CAN module (MXI1): Faulty emergency configuration [0x009f0000]

Module ID (decimal)	Error ID (decimal)
159: CAN module in MXI1: CAN emergency handler	0
<b>Reaction</b> (Lenze setting in bold)	
<input type="checkbox"/> None <input type="checkbox"/> System fault <input type="checkbox"/> Fault <input type="checkbox"/> Trouble <input type="checkbox"/> Quick stop by trouble <input checked="" type="checkbox"/> <b>Warning locked</b> <input type="checkbox"/> Warning <input type="checkbox"/> Information	
<b>Cause</b>	<b>Remedy</b>
CANopen communication module in MXI1: CAN emergency configuration is faulty. <ul style="list-style-type: none"> <li>• Faulty download of an Engineer or PLC Designer project</li> <li>• Invalid CAN emergency settings according to DS301V402 in the Engineer or PLC Designer.</li> </ul>	<ul style="list-style-type: none"> <li>• Repeat download</li> <li>• Correct CAN settings in the project and regenerate project.</li> </ul>

## CAN module (MXI1): Node guarding error 1 ... 32 [0x00a00000 ... 0x00a0001f]

Module ID (decimal)	Error ID (decimal)
160: CAN module in MXI1: CAN-NMT master	0 ... 31
<b>Reaction</b> (Lenze setting in bold)	
<b>Setting:</b> <a href="#">C13612/1...32</a> ( <input checked="" type="checkbox"/> Adjustable response)	
<input checked="" type="checkbox"/> <b>None</b> <input type="checkbox"/> System fault <input checked="" type="checkbox"/> Fault <input checked="" type="checkbox"/> Trouble <input checked="" type="checkbox"/> Quick stop by trouble <input checked="" type="checkbox"/> Warning locked <input checked="" type="checkbox"/> Warning <input checked="" type="checkbox"/> Information	
<b>Cause</b>	<b>Remedy</b>
CANopen communication module in MXI1: Cyclic node monitoring <ul style="list-style-type: none"> <li>• CAN master has not received a response to a node guarding telegram (remote transmission request telegram) from node 1 ... 32 within the defined time.</li> </ul>	<ul style="list-style-type: none"> <li>• Reactivate CAN node by mains switching, restart of the controller (<a href="#">C00002</a>="11000") or CAN reset node.</li> <li>• Select a different node guarding monitoring time or switch off monitoring.</li> <li>• Reset potentially caught error status.</li> </ul> Tip: Save the current parameter set before mains switching and restart of the controller ( <a href="#">C00002</a> ="11").

## CAN module (MXI1): Faulty NMT master configuration [0x00a00020]

Module ID (decimal)	Error ID (decimal)
160: CAN module in MXI1: CAN-NMT master	32
<b>Reaction</b> (Lenze setting in bold)	
<input type="checkbox"/> None <input type="checkbox"/> System fault <input type="checkbox"/> Fault <input type="checkbox"/> Trouble <input type="checkbox"/> Quick stop by trouble <input checked="" type="checkbox"/> <b>Warning locked</b> <input type="checkbox"/> Warning <input type="checkbox"/> Information	
<b>Cause</b>	<b>Remedy</b>
CANopen communication module in MXI1: A configuration error has occurred in the network management of the CAN master. <ul style="list-style-type: none"> <li>• Faulty download of an Engineer or PLC Designer project.</li> <li>• Invalid CAN master settings according to DS301V402 and DS405 in the Engineer or PLC Designer.</li> <li>• Incorrect parameterisation of node guarding or heartbeat.</li> </ul>	<ul style="list-style-type: none"> <li>• Repeat download</li> <li>• Correct CAN settings in the project and regenerate project.</li> </ul>

## CAN module (MXI1) RPDO1: Telegram not received or faulty [0x00a10000]

Module ID (decimal)	Error ID (decimal)
161: CAN module in MXI1: CAN-PDO handler	0
<b>Reaction</b> (Lenze setting in bold)	
Setting: <a href="#">C13591/1</a> ( <input checked="" type="checkbox"/> Adjustable response)	
<input checked="" type="checkbox"/> <b>None</b> <input type="checkbox"/> System fault <input checked="" type="checkbox"/> Fault <input checked="" type="checkbox"/> Trouble <input checked="" type="checkbox"/> Quick stop by trouble <input checked="" type="checkbox"/> Warning locked <input checked="" type="checkbox"/> Warning <input checked="" type="checkbox"/> Information	
<b>Cause</b>	<b>Remedy</b>
CANopen communication module in MXI1: CAN-IN 1 error <ul style="list-style-type: none"> <li>• Incorrect PDO telegram length.</li> <li>• Transmission error.</li> <li>• Time monitoring of the PDOs has tripped.</li> </ul>	<ul style="list-style-type: none"> <li>• Set correct telegram length for CAN master (transmitter).</li> <li>• Eliminate trouble in the environment (e. g. EMC).</li> <li>• Select a different time monitoring or switch off time monitoring.</li> </ul>

## CAN module (MXI1) RPDO2: Telegram not received or faulty [0x00a10001]

Module ID (decimal)	Error ID (decimal)
161: CAN module in MXI1: CAN-PDO handler	1
<b>Reaction</b> (Lenze setting in bold)	
Setting: <a href="#">C13591/2</a> ( <input checked="" type="checkbox"/> Adjustable response)	
<input checked="" type="checkbox"/> <b>None</b> <input type="checkbox"/> System fault <input checked="" type="checkbox"/> Fault <input checked="" type="checkbox"/> Trouble <input checked="" type="checkbox"/> Quick stop by trouble <input checked="" type="checkbox"/> Warning locked <input checked="" type="checkbox"/> Warning <input checked="" type="checkbox"/> Information	
<b>Cause</b>	<b>Remedy</b>
CANopen communication module in MXI1: CAN-IN 2 error <ul style="list-style-type: none"> <li>• Incorrect PDO telegram length.</li> <li>• Transmission error.</li> <li>• Time monitoring of the PDOs has tripped.</li> </ul>	<ul style="list-style-type: none"> <li>• Set correct telegram length for CAN master (transmitter).</li> <li>• Eliminate trouble in the environment (e. g. EMC).</li> <li>• Select a different time monitoring or switch off time monitoring.</li> </ul>

## CAN module (MXI1) RPDO3: Telegram not received or faulty [0x00a10002]

Module ID (decimal)	Error ID (decimal)
161: CAN module in MXI1: CAN-PDO handler	2
<b>Reaction</b> (Lenze setting in bold)	
Setting: <a href="#">C13591/3</a> ( <input checked="" type="checkbox"/> Adjustable response)	
<input checked="" type="checkbox"/> None <input type="checkbox"/> System fault <input checked="" type="checkbox"/> Fault <input checked="" type="checkbox"/> Trouble <input checked="" type="checkbox"/> Quick stop by trouble <input checked="" type="checkbox"/> Warning locked <input checked="" type="checkbox"/> Warning <input checked="" type="checkbox"/> Information	
Cause	Remedy
CANopen communication module in MXI1: CAN-IN 3 error <ul style="list-style-type: none"> <li>• Incorrect PDO telegram length.</li> <li>• Transmission error.</li> <li>• Time monitoring of the PDOs has tripped.</li> </ul>	<ul style="list-style-type: none"> <li>• Set correct telegram length for CAN master (transmitter).</li> <li>• Eliminate trouble in the environment (e. g. EMC).</li> <li>• Select a different time monitoring or switch off time monitoring.</li> </ul>

## CAN module (MXI1) RPDO4: Telegram not received or faulty [0x00a10003]

Module ID (decimal)	Error ID (decimal)
161: CAN module in MXI1: CAN-PDO handler	3
<b>Reaction</b> (Lenze setting in bold)	
Setting: <a href="#">C13591/4</a> ( <input checked="" type="checkbox"/> Adjustable response)	
<input checked="" type="checkbox"/> None <input type="checkbox"/> System fault <input checked="" type="checkbox"/> Fault <input checked="" type="checkbox"/> Trouble <input checked="" type="checkbox"/> Quick stop by trouble <input checked="" type="checkbox"/> Warning locked <input checked="" type="checkbox"/> Warning <input checked="" type="checkbox"/> Information	
Cause	Remedy
CANopen communication module in MXI1: CAN-IN 4 error <ul style="list-style-type: none"> <li>• Incorrect PDO telegram length.</li> <li>• Transmission error.</li> <li>• Time monitoring of the PDOs has tripped.</li> </ul>	<ul style="list-style-type: none"> <li>• Set correct telegram length for CAN master (transmitter).</li> <li>• Eliminate trouble in the environment (e. g. EMC).</li> <li>• Select a different time monitoring or switch off time monitoring.</li> </ul>

## CAN module (MXI1) RPDO5: Telegram not received or faulty [0x00a10004]

Module ID (decimal)	Error ID (decimal)
161: CAN module in MXI1: CAN-PDO handler	4
<b>Reaction</b> (Lenze setting in bold)	
Setting: <a href="#">C13591/5</a> ( <input checked="" type="checkbox"/> Adjustable response)	
<input checked="" type="checkbox"/> None <input type="checkbox"/> System fault <input checked="" type="checkbox"/> Fault <input checked="" type="checkbox"/> Trouble <input checked="" type="checkbox"/> Quick stop by trouble <input checked="" type="checkbox"/> Warning locked <input checked="" type="checkbox"/> Warning <input checked="" type="checkbox"/> Information	
Cause	Remedy
CANopen communication module in MXI1: CAN-IN 5 error <ul style="list-style-type: none"> <li>• Incorrect PDO telegram length.</li> <li>• Transmission error.</li> <li>• Time monitoring of the PDOs has tripped.</li> </ul>	<ul style="list-style-type: none"> <li>• Set correct telegram length for CAN master (transmitter).</li> <li>• Eliminate trouble in the environment (e. g. EMC).</li> <li>• Select a different time monitoring or switch off time monitoring.</li> </ul>

## CAN module (MXI1) RPDO6: Telegram not received or faulty [0x00a10005]

Module ID (decimal)	Error ID (decimal)
161: CAN module in MXI1: CAN-PDO handler	5
<b>Reaction</b> (Lenze setting in bold)	
Setting: <a href="#">C13591/6</a> ( <input checked="" type="checkbox"/> Adjustable response)	
<input checked="" type="checkbox"/> None <input type="checkbox"/> System fault <input checked="" type="checkbox"/> Fault <input checked="" type="checkbox"/> Trouble <input checked="" type="checkbox"/> Quick stop by trouble <input checked="" type="checkbox"/> Warning locked <input checked="" type="checkbox"/> Warning <input checked="" type="checkbox"/> Information	
Cause	Remedy
CANopen communication module in MXI1: CAN-IN 6 error <ul style="list-style-type: none"> <li>• Incorrect PDO telegram length.</li> <li>• Transmission error.</li> <li>• Time monitoring of the PDOs has tripped.</li> </ul>	<ul style="list-style-type: none"> <li>• Set correct telegram length for CAN master (transmitter).</li> <li>• Eliminate trouble in the environment (e. g. EMC).</li> <li>• Select a different time monitoring or switch off time monitoring.</li> </ul>

## CAN module (MXI1) RPDO7: Telegram not received or faulty [0x00a10006]

Module ID (decimal)	Error ID (decimal)
161: CAN module in MXI1: CAN-PDO handler	6
<b>Reaction</b> (Lenze setting in bold)	
Setting: <a href="#">C13591/7</a> ( <input checked="" type="checkbox"/> Adjustable response)	
<input checked="" type="checkbox"/> None <input type="checkbox"/> System fault <input checked="" type="checkbox"/> Fault <input checked="" type="checkbox"/> Trouble <input checked="" type="checkbox"/> Quick stop by trouble <input checked="" type="checkbox"/> Warning locked <input checked="" type="checkbox"/> Warning <input checked="" type="checkbox"/> Information	
Cause	Remedy
CANopen communication module in MXI1: CAN-IN 7 error <ul style="list-style-type: none"> <li>• Incorrect PDO telegram length.</li> <li>• Transmission error.</li> <li>• Time monitoring of the PDOs has tripped.</li> </ul>	<ul style="list-style-type: none"> <li>• Set correct telegram length for CAN master (transmitter).</li> <li>• Eliminate trouble in the environment (e. g. EMC).</li> <li>• Select a different time monitoring or switch off time monitoring.</li> </ul>

## CAN module (MXI1) RPDO8: Telegram not received or faulty [0x00a10007]

Module ID (decimal)	Error ID (decimal)
161: CAN module in MXI1: CAN-PDO handler	7
<b>Reaction</b> (Lenze setting in bold)	
Setting: <a href="#">C13591/8</a> ( <input checked="" type="checkbox"/> Adjustable response)	
<input checked="" type="checkbox"/> None <input type="checkbox"/> System fault <input checked="" type="checkbox"/> Fault <input checked="" type="checkbox"/> Trouble <input checked="" type="checkbox"/> Quick stop by trouble <input checked="" type="checkbox"/> Warning locked <input checked="" type="checkbox"/> Warning <input checked="" type="checkbox"/> Information	
Cause	Remedy
CANopen communication module in MXI1: CAN-IN 8 error <ul style="list-style-type: none"> <li>• Incorrect PDO telegram length.</li> <li>• Transmission error.</li> <li>• Time monitoring of the PDOs has tripped.</li> </ul>	<ul style="list-style-type: none"> <li>• Set correct telegram length for CAN master (transmitter).</li> <li>• Eliminate trouble in the environment (e. g. EMC).</li> <li>• Select a different time monitoring or switch off time monitoring.</li> </ul>

## CAN module (MXI1) PDO manager: Faulty configuration [0x00a10008]

Module ID (decimal)	Error ID (decimal)
161: CAN module in MXI1: CAN-PDO handler	8
<b>Reaction</b> (Lenze setting in bold)	
<input type="checkbox"/> None <input type="checkbox"/> System fault <input type="checkbox"/> Fault <input type="checkbox"/> Trouble <input type="checkbox"/> Quick stop by trouble <input checked="" type="checkbox"/> Warning locked <input type="checkbox"/> Warning <input type="checkbox"/> Information	
Cause	Remedy
CANopen communication module in MXI1: CAN-PDO configuration error <ul style="list-style-type: none"> <li>• Faulty project download.</li> <li>• Invalid CAN settings according to DS301V402 in the Engineer or PLC Designer.</li> <li>• Mapping variables have incorrect CANopen indices according to DS405.</li> </ul>	<ul style="list-style-type: none"> <li>• Repeat download.</li> <li>• Correct CAN settings in the project and regenerate project.</li> </ul>

## CAN module (MXI1) SDO server: Faulty configuration [0x00a20000]

Module ID (decimal)	Error ID (decimal)
162: CAN module in MXI1: CAN-SDO server	0
<b>Reaction</b> (Lenze setting in bold)	
<input type="checkbox"/> None <input type="checkbox"/> System fault <input type="checkbox"/> Fault <input type="checkbox"/> Trouble <input type="checkbox"/> Quick stop by trouble <input checked="" type="checkbox"/> Warning locked <input type="checkbox"/> Warning <input type="checkbox"/> Information	
Cause	Remedy
CANopen communication module in MXI1: In the CAN SDO server a configuration error has occurred. <ul style="list-style-type: none"> <li>• Faulty project download.</li> <li>• Invalid SDO server settings according to DS301V402 in the Engineer or PLC Designer.</li> </ul>	<ul style="list-style-type: none"> <li>• Repeat download.</li> <li>• Correct CAN settings in the project and regenerate project.</li> </ul>

## CAN module (MXI1) SDO client: Faulty configuration [0x00a30000]

Module ID (decimal)	Error ID (decimal)
163: CAN module in MXI1: CAN-SDO client	0
<b>Reaction</b> (Lenze setting in bold)	
<input type="checkbox"/> None <input type="checkbox"/> System fault <input type="checkbox"/> Fault <input type="checkbox"/> Trouble <input type="checkbox"/> Quick stop by trouble <input checked="" type="checkbox"/> <b>Warning locked</b> <input type="checkbox"/> Warning <input type="checkbox"/> Information	
<b>Cause</b>	<b>Remedy</b>
CANopen communication module in MXI1: In the CAN SDO client a configuration error has occurred. <ul style="list-style-type: none"> <li>• Faulty project download.</li> <li>• Invalid SDO client settings according to DS301V402 in the Engineer or PLC Designer.</li> </ul>	<ul style="list-style-type: none"> <li>• Repeat download</li> <li>• Correct CAN settings in the project and regenerate project.</li> </ul>

## DFIN (MXI2): Track error A-/A [0x00aa0000]

Module ID (decimal)	Error ID (decimal)
170: Extension module - digital frequency in MXI2	0
<b>Reaction</b> (Lenze setting in bold)	
Setting: <a href="#">C14040</a> ( <input checked="" type="checkbox"/> Adjustable response)	
<input checked="" type="checkbox"/> None <input type="checkbox"/> System fault <input checked="" type="checkbox"/> <b>Fault</b> <input checked="" type="checkbox"/> Trouble <input checked="" type="checkbox"/> Quick stop by trouble <input checked="" type="checkbox"/> Warning locked <input checked="" type="checkbox"/> Warning <input checked="" type="checkbox"/> Information	
<b>Cause</b>	<b>Remedy</b>
Digital frequency extension module in MXI2: Interruption (open circuit) of the signal cable for track A.	<ul style="list-style-type: none"> <li>• Check signal cable for track A.</li> <li>• Check encoder.</li> </ul>

## DFIN (MXI2): Track error B-/B [0x00aa0001]

Module ID (decimal)	Error ID (decimal)
170: Extension module - digital frequency in MXI2	1
<b>Reaction</b> (Lenze setting in bold)	
Setting: <a href="#">C14040</a> ( <input checked="" type="checkbox"/> Adjustable response)	
<input checked="" type="checkbox"/> None <input type="checkbox"/> System fault <input checked="" type="checkbox"/> <b>Fault</b> <input checked="" type="checkbox"/> Trouble <input checked="" type="checkbox"/> Quick stop by trouble <input checked="" type="checkbox"/> Warning locked <input checked="" type="checkbox"/> Warning <input checked="" type="checkbox"/> Information	
<b>Cause</b>	<b>Remedy</b>
Digital frequency extension module in MXI2: Interruption (open circuit) of the signal cable for track B.	<ul style="list-style-type: none"> <li>• Check signal cable for track B.</li> <li>• Check encoder.</li> </ul>

## DFIN (MXI2): Track error Z-/Z [0x00aa0002]

Module ID (decimal)	Error ID (decimal)
170: Extension module - digital frequency in MXI2	2
<b>Reaction</b> (Lenze setting in bold)	
Setting: <a href="#">C14040</a> ( <input checked="" type="checkbox"/> Adjustable response)	
<input checked="" type="checkbox"/> None <input type="checkbox"/> System fault <input checked="" type="checkbox"/> <b>Fault</b> <input checked="" type="checkbox"/> Trouble <input checked="" type="checkbox"/> Quick stop by trouble <input checked="" type="checkbox"/> Warning locked <input checked="" type="checkbox"/> Warning <input checked="" type="checkbox"/> Information	
<b>Cause</b>	<b>Remedy</b>
Digital frequency extension module in MXI2: Interruption (open circuit) of the signal cable for track Z.	<ul style="list-style-type: none"> <li>• Check signal cable for track Z.</li> <li>• Check encoder.</li> </ul>

**DFIN (MXI2): Signal error enable/lamp control [0x00aa0003]**

Module ID (decimal)	Error ID (decimal)
170: Extension module - digital frequency in MXI2	3
Reaction (Lenze setting in bold)	Setting: <a href="#">C14041</a> ( <input checked="" type="checkbox"/> Adjustable response)
<input checked="" type="checkbox"/> None <input type="checkbox"/> System fault <input checked="" type="checkbox"/> Fault <input checked="" type="checkbox"/> Trouble <input checked="" type="checkbox"/> Quick stop by trouble <input checked="" type="checkbox"/> Warning locked <input checked="" type="checkbox"/> <b>Warning</b> <input checked="" type="checkbox"/> Information	
Cause	Remedy
Digital frequency extension module in MXI2: Interruption (open circuit) of the signal cable for the "Enable" signal or no "Enable" signal available.	<ul style="list-style-type: none"> <li>• Check signal cable for "Enable" signal.</li> <li>• Check encoder.</li> </ul>

**DFIN (MXI2): Supply cannot be corrected anymore [0x00aa0004]**

Module ID (decimal)	Error ID (decimal)
170: Extension module - digital frequency in MXI2	4
Reaction (Lenze setting in bold)	Setting: <a href="#">C14042</a> ( <input checked="" type="checkbox"/> Adjustable response)
<input checked="" type="checkbox"/> None <input type="checkbox"/> System fault <input checked="" type="checkbox"/> Fault <input checked="" type="checkbox"/> Trouble <input checked="" type="checkbox"/> Quick stop by trouble <input checked="" type="checkbox"/> Warning locked <input checked="" type="checkbox"/> <b>Warning</b> <input checked="" type="checkbox"/> Information	
Cause	Remedy
Digital frequency extension module in MXI2: The encoder voltage controlled by the digital frequency input has reached the voltage limit.	Check encoder.

**DFOUT (MXI2): Maximum frequency reached [0x00aa0005]**

Module ID (decimal)	Error ID (decimal)
170: Extension module - digital frequency in MXI2	5
Reaction (Lenze setting in bold)	Setting: <a href="#">C14080</a> ( <input checked="" type="checkbox"/> Adjustable response)
<input checked="" type="checkbox"/> None <input type="checkbox"/> System fault <input checked="" type="checkbox"/> Fault <input checked="" type="checkbox"/> Trouble <input checked="" type="checkbox"/> Quick stop by trouble <input checked="" type="checkbox"/> Warning locked <input checked="" type="checkbox"/> <b>Warning</b> <input checked="" type="checkbox"/> Information	
Cause	Remedy
Digital frequency extension module in MXI2: Limit frequency at the digital frequency output reached. <ul style="list-style-type: none"> <li>• The digital frequency has reached the limit value set in <a href="#">C014053</a>.</li> </ul>	Check limit value set.

**CAN module (MXI2): Bus off [0x00ac0000]**

Module ID (decimal)	Error ID (decimal)
172: CAN module in MXI2: CAN dispatcher	0
Reaction (Lenze setting in bold)	Setting: <a href="#">C14595</a> ( <input checked="" type="checkbox"/> Adjustable response)
<input checked="" type="checkbox"/> None <input type="checkbox"/> System fault <input checked="" type="checkbox"/> Fault <input checked="" type="checkbox"/> Trouble <input checked="" type="checkbox"/> Quick stop by trouble <input checked="" type="checkbox"/> Warning locked <input checked="" type="checkbox"/> <b>Warning</b> <input checked="" type="checkbox"/> <b>Information</b>	
Cause	Remedy
CANopen communication module in MXI2: "Bus-off" state <ul style="list-style-type: none"> <li>• Received too many faulty telegrams.</li> <li>• Defective cable (e.g. loose contact).</li> <li>• Two nodes with the same ID.</li> </ul>	<ul style="list-style-type: none"> <li>• Remove fault (e.g. EMC).</li> <li>• Remove loose contact, screw down adapter.</li> <li>• Assign different IDs to nodes.</li> </ul>

**CAN module (MXI2): Invalid node address 0 [0x00ac0001]**

Module ID (decimal)	Error ID (decimal)
172: CAN module in MXI2: CAN dispatcher	1
<b>Reaction</b> (Lenze setting in bold)	
<input type="checkbox"/> None <input type="checkbox"/> System fault <input type="checkbox"/> Fault <input type="checkbox"/> Trouble <input type="checkbox"/> Quick stop by trouble <input type="checkbox"/> Warning locked <input checked="" type="checkbox"/> <b>Warning</b> <input type="checkbox"/> Information	
<b>Cause</b>	<b>Remedy</b>
CANopen communication module in MXI2: Initialisation error <ul style="list-style-type: none"> <li>The hardware allocation of the node address was selected via DIP switches, and the DIP switches of the node address are all on zero.</li> </ul> <b>Note:</b> Instead of the impermissible node address 0, node address 1 is used.	<ul style="list-style-type: none"> <li>Set a non-zero node address by means of the DIP switches and then switch mains.</li> <li>Activation of the software allocation of the node number by switching over DIP switch 2, then switch mains.</li> </ul>

**CAN module (MXI2): Basic configuration invalid [0x00ac0002]**

Module ID (decimal)	Error ID (decimal)
172: CAN module in MXI2: CAN dispatcher	2
<b>Reaction</b> (Lenze setting in bold)	
<input type="checkbox"/> None <input type="checkbox"/> System fault <input type="checkbox"/> Fault <input type="checkbox"/> Trouble <input type="checkbox"/> Quick stop by trouble <input checked="" type="checkbox"/> <b>Warning locked</b> <input type="checkbox"/> Warning <input type="checkbox"/> Information	
<b>Cause</b>	<b>Remedy</b>
CANopen communication module in MXI2: Configuration error <ul style="list-style-type: none"> <li>Faulty download of an Engineer or PLC Designer project</li> <li>Invalid CAN settings according to DS301V402 in the Engineer or PLC Designer.</li> </ul>	<ul style="list-style-type: none"> <li>Repeat download</li> <li>Correct CAN settings in the project and regenerate project.</li> </ul>

**CAN module (MXI2): Heartbeat error index 1 ... 32 [0x00ad0000 ... 0x00ad001f]**

Module ID (decimal)	Error ID (decimal)
173: CAN module in MXI2: CAN-NMT handler	0 ... 31
<b>Reaction</b> (Lenze setting in bold)	
<input checked="" type="checkbox"/> <b>None</b> <input type="checkbox"/> System fault <input checked="" type="checkbox"/> Fault <input checked="" type="checkbox"/> Trouble <input checked="" type="checkbox"/> Quick stop by trouble <input checked="" type="checkbox"/> Warning locked <input checked="" type="checkbox"/> Warning <input checked="" type="checkbox"/> Information	
<b>Setting:</b> <a href="#">C14613/1...32</a> ( <input checked="" type="checkbox"/> Adjustable response)	
<b>Cause</b>	<b>Remedy</b>
CANopen communication module in MXI2: Cyclic node monitoring <ul style="list-style-type: none"> <li>Node station has not received a heartbeat telegram from node 1 ... 32 within the defined time.</li> </ul>	<ul style="list-style-type: none"> <li>Reactivate CAN node by mains switching, restart of the controller (<a href="#">C00002</a>="11000") or CAN reset node.</li> <li>Select a different heartbeat producer monitoring time or switch off monitoring and reset locked error status, if necessary.</li> </ul> <b>Tip:</b> Save the current parameter set before mains switching and restart of the controller ( <a href="#">C00002</a> ="11").

## CAN module (MXI2): Lifeguarding error [0x00ad0020]

Module ID (decimal)	Error ID (decimal)
173: CAN module in MXI2: CAN-NMT handler	32
<b>Reaction</b> (Lenze setting in bold)	
<input checked="" type="checkbox"/> <b>None</b> <input type="checkbox"/> System fault <input checked="" type="checkbox"/> Fault <input checked="" type="checkbox"/> Trouble <input checked="" type="checkbox"/> Quick stop by trouble <input checked="" type="checkbox"/> Warning locked <input checked="" type="checkbox"/> Warning <input checked="" type="checkbox"/> Information	
<b>Setting:</b> C14614 ( <input checked="" type="checkbox"/> Adjustable response)	
Cause	Remedy
CANopen communication module in MXI2: Cyclic node monitoring <ul style="list-style-type: none"> <li>• Slave response: Maximum time between two node guarding telegrams (remote transmission request telegram) from the master has been exceeded.</li> </ul>	Select a different Lifeguarding monitoring time or switch off monitoring.

## CAN module (MXI2): Faulty NMT slave configuration [0x00ad0021]

Module ID (decimal)	Error ID (decimal)
173: CAN module in MXI2: CAN-NMT handler	33
<b>Reaction</b> (Lenze setting in bold)	
<input type="checkbox"/> None <input type="checkbox"/> System fault <input type="checkbox"/> Fault <input type="checkbox"/> Trouble <input type="checkbox"/> Quick stop by trouble <input checked="" type="checkbox"/> <b>Warning locked</b> <input type="checkbox"/> Warning <input type="checkbox"/> Information	
Cause	Remedy
CANopen communication module in MXI2: A configuration error has occurred in the network management of the CAN slave. <ul style="list-style-type: none"> <li>• Faulty download of an Engineer or PLC Designer project</li> <li>• Invalid CAN settings according to DS301V402 in the Engineer or PLC Designer.</li> <li>• Incorrect parameterisation of node guarding or heartbeat.</li> </ul>	<ul style="list-style-type: none"> <li>• Repeat download</li> <li>• Correct CAN settings in the project and regenerate project.</li> </ul>

## CAN module (MXI2): Faulty emergency configuration [0x00ae0000]

Module ID (decimal)	Error ID (decimal)
174: CAN module in MXI2: CAN emergency handler	0
<b>Reaction</b> (Lenze setting in bold)	
<input type="checkbox"/> None <input type="checkbox"/> System fault <input type="checkbox"/> Fault <input type="checkbox"/> Trouble <input type="checkbox"/> Quick stop by trouble <input checked="" type="checkbox"/> <b>Warning locked</b> <input type="checkbox"/> Warning <input type="checkbox"/> Information	
Cause	Remedy
CANopen communication module in MXI2: CAN emergency configuration is faulty. <ul style="list-style-type: none"> <li>• Faulty download of an Engineer or PLC Designer project</li> <li>• Invalid CAN emergency settings according to DS301V402 in the Engineer or PLC Designer.</li> </ul>	<ul style="list-style-type: none"> <li>• Repeat download</li> <li>• Correct CAN settings in the project and regenerate project.</li> </ul>



## CAN module (MXI2): Node guarding error 1 ... 32 [0x00af0000 ... 0x00a0001f]

Module ID (decimal)	Error ID (decimal)
175: CAN module in MXI2: CAN-NMT master	0 ... 31
<b>Reaction</b> (Lenze setting in bold)	
Setting: <a href="#">C14612/1...32</a> ( <input checked="" type="checkbox"/> Adjustable response)	
<input checked="" type="checkbox"/> None <input type="checkbox"/> System fault <input checked="" type="checkbox"/> Fault <input checked="" type="checkbox"/> Trouble <input checked="" type="checkbox"/> Quick stop by trouble <input checked="" type="checkbox"/> Warning locked <input checked="" type="checkbox"/> Warning <input checked="" type="checkbox"/> Information	
Cause	Remedy
CANopen communication module in MXI2: Cyclic node monitoring <ul style="list-style-type: none"> <li>CAN master has not received a response to a node guarding telegram (remote transmission request telegram) from node 1 ... 32 within the defined time.</li> </ul>	<ul style="list-style-type: none"> <li>Reactivate CAN node by mains switching, restart of the controller (<a href="#">C00002</a>="11000") or CAN reset node.</li> <li>Select a different node guarding monitoring time or switch off monitoring.</li> <li>Reset potentially caught error status.</li> </ul> Tip: Save the current parameter set before mains switching and restart of the controller ( <a href="#">C00002</a> ="11").

## CAN module (MXI2): Faulty NMT master configuration [0x00af0020]

Module ID (decimal)	Error ID (decimal)
175: CAN module in MXI2: CAN-NMT master	32
<b>Reaction</b> (Lenze setting in bold)	
<input type="checkbox"/> None <input type="checkbox"/> System fault <input type="checkbox"/> Fault <input type="checkbox"/> Trouble <input type="checkbox"/> Quick stop by trouble <input checked="" type="checkbox"/> Warning locked <input type="checkbox"/> Warning <input type="checkbox"/> Information	
Cause	Remedy
CANopen communication module in MXI2: A configuration error has occurred in the network management of the CAN master. <ul style="list-style-type: none"> <li>Faulty download of an Engineer or PLC Designer project.</li> <li>Invalid CAN master settings according to DS301V402 and DS405 in the Engineer or PLC Designer.</li> <li>Incorrect parameterisation of node guarding or heartbeat.</li> </ul>	<ul style="list-style-type: none"> <li>Repeat download</li> <li>Correct CAN settings in the project and regenerate project.</li> </ul>

## CAN module (MXI2) RPDO1: Telegram not received or faulty [0x00b00000]

Module ID (decimal)	Error ID (decimal)
176: CAN module in MXI2: CAN-PDO handler	0
<b>Reaction</b> (Lenze setting in bold)	
Setting: <a href="#">C14591/1</a> ( <input checked="" type="checkbox"/> Adjustable response)	
<input checked="" type="checkbox"/> None <input type="checkbox"/> System fault <input checked="" type="checkbox"/> Fault <input checked="" type="checkbox"/> Trouble <input checked="" type="checkbox"/> Quick stop by trouble <input checked="" type="checkbox"/> Warning locked <input checked="" type="checkbox"/> Warning <input checked="" type="checkbox"/> Information	
Cause	Remedy
CANopen communication module in MXI2: CAN-IN 1 error <ul style="list-style-type: none"> <li>Incorrect PDO telegram length.</li> <li>Transmission error.</li> <li>Time monitoring of the PDOs has tripped.</li> </ul>	<ul style="list-style-type: none"> <li>Set correct telegram length for CAN master (transmitter).</li> <li>Eliminate trouble in the environment (e. g. EMC).</li> <li>Select a different time monitoring or switch off time monitoring.</li> </ul>

## CAN module (MXI2) RPDO2: Telegram not received or faulty [0x00b00001]

Module ID (decimal)	Error ID (decimal)
176: CAN module in MXI2: CAN-PDO handler	1
<b>Reaction</b> (Lenze setting in bold)	
Setting: <a href="#">C14591/2</a> ( <input checked="" type="checkbox"/> Adjustable response)	
<input checked="" type="checkbox"/> <b>None</b> <input type="checkbox"/> System fault <input checked="" type="checkbox"/> Fault <input checked="" type="checkbox"/> Trouble <input checked="" type="checkbox"/> Quick stop by trouble <input checked="" type="checkbox"/> Warning locked <input checked="" type="checkbox"/> Warning <input checked="" type="checkbox"/> Information	
Cause	Remedy
CANopen communication module in MXI2: CAN-IN 2 error <ul style="list-style-type: none"> <li>• Incorrect PDO telegram length.</li> <li>• Transmission error.</li> <li>• Time monitoring of the PDOs has tripped.</li> </ul>	<ul style="list-style-type: none"> <li>• Set correct telegram length for CAN master (transmitter).</li> <li>• Eliminate trouble in the environment (e. g. EMC).</li> <li>• Select a different time monitoring or switch off time monitoring.</li> </ul>

## CAN module (MXI2) RPDO3: Telegram not received or faulty [0x00b00002]

Module ID (decimal)	Error ID (decimal)
176: CAN module in MXI2: CAN-PDO handler	2
<b>Reaction</b> (Lenze setting in bold)	
Setting: <a href="#">C14591/3</a> ( <input checked="" type="checkbox"/> Adjustable response)	
<input checked="" type="checkbox"/> <b>None</b> <input type="checkbox"/> System fault <input checked="" type="checkbox"/> Fault <input checked="" type="checkbox"/> Trouble <input checked="" type="checkbox"/> Quick stop by trouble <input checked="" type="checkbox"/> Warning locked <input checked="" type="checkbox"/> Warning <input checked="" type="checkbox"/> Information	
Cause	Remedy
CANopen communication module in MXI2: CAN-IN 3 error <ul style="list-style-type: none"> <li>• Incorrect PDO telegram length.</li> <li>• Transmission error.</li> <li>• Time monitoring of the PDOs has tripped.</li> </ul>	<ul style="list-style-type: none"> <li>• Set correct telegram length for CAN master (transmitter).</li> <li>• Eliminate trouble in the environment (e. g. EMC).</li> <li>• Select a different time monitoring or switch off time monitoring.</li> </ul>

## CAN module (MXI2) RPDO4: Telegram not received or faulty [0x00b00003]

Module ID (decimal)	Error ID (decimal)
176: CAN module in MXI2: CAN-PDO handler	3
<b>Reaction</b> (Lenze setting in bold)	
Setting: <a href="#">C14591/4</a> ( <input checked="" type="checkbox"/> Adjustable response)	
<input checked="" type="checkbox"/> <b>None</b> <input type="checkbox"/> System fault <input checked="" type="checkbox"/> Fault <input checked="" type="checkbox"/> Trouble <input checked="" type="checkbox"/> Quick stop by trouble <input checked="" type="checkbox"/> Warning locked <input checked="" type="checkbox"/> Warning <input checked="" type="checkbox"/> Information	
Cause	Remedy
CANopen communication module in MXI2: CAN-IN 4 error <ul style="list-style-type: none"> <li>• Incorrect PDO telegram length.</li> <li>• Transmission error.</li> <li>• Time monitoring of the PDOs has tripped.</li> </ul>	<ul style="list-style-type: none"> <li>• Set correct telegram length for CAN master (transmitter).</li> <li>• Eliminate trouble in the environment (e. g. EMC).</li> <li>• Select a different time monitoring or switch off time monitoring.</li> </ul>

## CAN module (MXI2) RPDO5: Telegram not received or faulty [0x00b00004]

Module ID (decimal)	Error ID (decimal)
176: CAN module in MXI2: CAN-PDO handler	4
<b>Reaction</b> (Lenze setting in bold)	
Setting: <a href="#">C14591/5</a> ( <input checked="" type="checkbox"/> Adjustable response)	
<input checked="" type="checkbox"/> <b>None</b> <input type="checkbox"/> System fault <input checked="" type="checkbox"/> Fault <input checked="" type="checkbox"/> Trouble <input checked="" type="checkbox"/> Quick stop by trouble <input checked="" type="checkbox"/> Warning locked <input checked="" type="checkbox"/> Warning <input checked="" type="checkbox"/> Information	
Cause	Remedy
CANopen communication module in MXI2: CAN-IN 5 error <ul style="list-style-type: none"> <li>• Incorrect PDO telegram length.</li> <li>• Transmission error.</li> <li>• Time monitoring of the PDOs has tripped.</li> </ul>	<ul style="list-style-type: none"> <li>• Set correct telegram length for CAN master (transmitter).</li> <li>• Eliminate trouble in the environment (e. g. EMC).</li> <li>• Select a different time monitoring or switch off time monitoring.</li> </ul>

## CAN module (MXI2) RPDO6: Telegram not received or faulty [0x00b00005]

Module ID (decimal)	Error ID (decimal)
176: CAN module in MXI2: CAN-PDO handler	5
<b>Reaction</b> (Lenze setting in bold)	
Setting: <a href="#">C14591/6</a> ( <input checked="" type="checkbox"/> Adjustable response)	
<input checked="" type="checkbox"/> None <input type="checkbox"/> System fault <input checked="" type="checkbox"/> Fault <input checked="" type="checkbox"/> Trouble <input checked="" type="checkbox"/> Quick stop by trouble <input checked="" type="checkbox"/> Warning locked <input checked="" type="checkbox"/> Warning <input checked="" type="checkbox"/> Information	
Cause	Remedy
CANopen communication module in MXI2: CAN-IN 6 error <ul style="list-style-type: none"> <li>• Incorrect PDO telegram length.</li> <li>• Transmission error.</li> <li>• Time monitoring of the PDOs has tripped.</li> </ul>	<ul style="list-style-type: none"> <li>• Set correct telegram length for CAN master (transmitter).</li> <li>• Eliminate trouble in the environment (e. g. EMC).</li> <li>• Select a different time monitoring or switch off time monitoring.</li> </ul>

## CAN module (MXI2) RPDO7: Telegram not received or faulty [0x00b00006]

Module ID (decimal)	Error ID (decimal)
176: CAN module in MXI2: CAN-PDO handler	6
<b>Reaction</b> (Lenze setting in bold)	
Setting: <a href="#">C14591/7</a> ( <input checked="" type="checkbox"/> Adjustable response)	
<input checked="" type="checkbox"/> None <input type="checkbox"/> System fault <input checked="" type="checkbox"/> Fault <input checked="" type="checkbox"/> Trouble <input checked="" type="checkbox"/> Quick stop by trouble <input checked="" type="checkbox"/> Warning locked <input checked="" type="checkbox"/> Warning <input checked="" type="checkbox"/> Information	
Cause	Remedy
CANopen communication module in MXI2: CAN-IN 7 error <ul style="list-style-type: none"> <li>• Incorrect PDO telegram length.</li> <li>• Transmission error.</li> <li>• Time monitoring of the PDOs has tripped.</li> </ul>	<ul style="list-style-type: none"> <li>• Set correct telegram length for CAN master (transmitter).</li> <li>• Eliminate trouble in the environment (e. g. EMC).</li> <li>• Select a different time monitoring or switch off time monitoring.</li> </ul>

## CAN module (MXI2) RPDO8: Telegram not received or faulty [0x00b00007]

Module ID (decimal)	Error ID (decimal)
176: CAN module in MXI2: CAN-PDO handler	7
<b>Reaction</b> (Lenze setting in bold)	
Setting: <a href="#">C14591/8</a> ( <input checked="" type="checkbox"/> Adjustable response)	
<input checked="" type="checkbox"/> None <input type="checkbox"/> System fault <input checked="" type="checkbox"/> Fault <input checked="" type="checkbox"/> Trouble <input checked="" type="checkbox"/> Quick stop by trouble <input checked="" type="checkbox"/> Warning locked <input checked="" type="checkbox"/> Warning <input checked="" type="checkbox"/> Information	
Cause	Remedy
CANopen communication module in MXI2: CAN-IN 8 error <ul style="list-style-type: none"> <li>• Incorrect PDO telegram length.</li> <li>• Transmission error.</li> <li>• Time monitoring of the PDOs has tripped.</li> </ul>	<ul style="list-style-type: none"> <li>• Set correct telegram length for CAN master (transmitter).</li> <li>• Eliminate trouble in the environment (e. g. EMC).</li> <li>• Select a different time monitoring or switch off time monitoring.</li> </ul>

## CAN module (MXI2) PDO manager: Faulty configuration [0x00b00008]

Module ID (decimal)	Error ID (decimal)
176: CAN module in MXI2: CAN-PDO handler	8
<b>Reaction</b> (Lenze setting in bold)	
<input type="checkbox"/> None <input type="checkbox"/> System fault <input type="checkbox"/> Fault <input type="checkbox"/> Trouble <input type="checkbox"/> Quick stop by trouble <input checked="" type="checkbox"/> Warning locked <input type="checkbox"/> Warning <input type="checkbox"/> Information	
Cause	Remedy
CANopen communication module in MXI2: CAN-PDO configuration error <ul style="list-style-type: none"> <li>• Faulty project download.</li> <li>• Invalid CAN settings according to DS301V402 in the Engineer or PLC Designer.</li> <li>• Mapping variables have incorrect CANopen indices according to DS405.</li> </ul>	<ul style="list-style-type: none"> <li>• Repeat download.</li> <li>• Correct CAN settings in the project and regenerate project.</li> </ul>

## CAN module (MXI2) SDO server: Faulty configuration [0x00b10000]

Module ID (decimal)	Error ID (decimal)
177: CAN module in MXI2: CAN-SDO server	0
<b>Reaction</b> (Lenze setting in bold)	
<input type="checkbox"/> None <input type="checkbox"/> System fault <input type="checkbox"/> Fault <input type="checkbox"/> Trouble <input type="checkbox"/> Quick stop by trouble <input checked="" type="checkbox"/> <b>Warning locked</b> <input type="checkbox"/> Warning <input type="checkbox"/> Information	
<b>Cause</b>	<b>Remedy</b>
CANopen communication module in MXI2: In the CAN SDO server a configuration error has occurred. <ul style="list-style-type: none"> <li>• Faulty project download.</li> <li>• Invalid SDO server settings according to DS301V402 in the Engineer or PLC Designer.</li> </ul>	<ul style="list-style-type: none"> <li>• Repeat download.</li> <li>• Correct CAN settings in the project and regenerate project.</li> </ul>

## CAN module (MXI2) SDO client: Faulty configuration [0x00b20000]

Module ID (decimal)	Error ID (decimal)
178: CAN module in MXI2: CAN-SDO client	0
<b>Reaction</b> (Lenze setting in bold)	
<input type="checkbox"/> None <input type="checkbox"/> System fault <input type="checkbox"/> Fault <input type="checkbox"/> Trouble <input type="checkbox"/> Quick stop by trouble <input checked="" type="checkbox"/> <b>Warning locked</b> <input type="checkbox"/> Warning <input type="checkbox"/> Information	
<b>Cause</b>	<b>Remedy</b>
CANopen communication module in MXI2: In the CAN SDO client a configuration error has occurred. <ul style="list-style-type: none"> <li>• Faulty project download.</li> <li>• Invalid SDO client settings according to DS301V402 in the Engineer or PLC Designer.</li> </ul>	<ul style="list-style-type: none"> <li>• Repeat download</li> <li>• Correct CAN settings in the project and regenerate project.</li> </ul>

## PLC configuration invalid [0x00b80000]

Module ID (decimal)	Error ID (decimal)
184: Basic drive functions	0
<b>Reaction</b> (Lenze setting in bold)	
<input type="checkbox"/> None <input type="checkbox"/> System fault <input checked="" type="checkbox"/> <b>Fault</b> <input type="checkbox"/> Trouble <input type="checkbox"/> Quick stop by trouble <input type="checkbox"/> Warning locked <input type="checkbox"/> Warning <input type="checkbox"/> Information	
<b>Cause</b>	<b>Remedy</b>
An invalid control configuration has occurred.	Load a different application.

## Positive limit switch has triggered [0x00b80001]

Module ID (decimal)	Error ID (decimal)
184: Basic drive functions	1
<b>Reaction</b> (Lenze setting in bold)	
<input type="checkbox"/> None <input type="checkbox"/> System fault <input type="checkbox"/> Fault <input type="checkbox"/> Trouble <input checked="" type="checkbox"/> <b>Quick stop by trouble</b> <input type="checkbox"/> Warning locked <input type="checkbox"/> Warning <input type="checkbox"/> Information	
<b>Cause</b>	<b>Remedy</b>
The <a href="#">travel range limit switch</a> in positive traversing direction has tripped.	Reset fault message and <a href="#">retract limit switch</a> .

**Negative limit switch has triggered [0x00b80002]**

Module ID (decimal)	Error ID (decimal)
184: Basic drive functions	2
<b>Reaction (Lenze setting in bold)</b>	
<input type="checkbox"/> None <input type="checkbox"/> System fault <input type="checkbox"/> Fault <input type="checkbox"/> Trouble <input checked="" type="checkbox"/> <b>Quick stop by trouble</b> <input type="checkbox"/> Warning locked <input type="checkbox"/> Warning <input type="checkbox"/> Information	
<b>Cause</b>	
The <a href="#">travel range limit switch</a> in negative traversing direction has tripped.	<b>Remedy</b>
	Reset fault message and <a href="#">retract limit switch</a> .

**Motor brake: Angular drift with closed brake too high [0x00b80003]**

Module ID (decimal)	Error ID (decimal)
184: Basic drive functions	3
<b>Reaction (Lenze setting in bold)</b>	
<input type="checkbox"/> None <input type="checkbox"/> System fault <input type="checkbox"/> Fault <input type="checkbox"/> Trouble <input checked="" type="checkbox"/> <b>Quick stop by trouble</b> <input type="checkbox"/> Warning locked <input type="checkbox"/> Warning <input type="checkbox"/> Information	
<b>Cause</b>	
The stop position of the motor axis has changed by more than the permissible angle of rotation set in <a href="#">C02595</a> , although the brake is engaged.	<b>Remedy</b>
	<ul style="list-style-type: none"> <li>• Deactivate standstill monitoring (<a href="#">C02595</a> = 0).</li> <li>• Increase waiting time for status monitoring (<a href="#">C02591</a>). The standstill monitoring only starts after this waiting time has elapsed.</li> <li>• Increase brake closing time (<a href="#">C02589</a>) since during the brake closing time the standstill monitoring is not active.</li> <li>• Reduce threshold for brake activation (<a href="#">C02581</a>).</li> </ul>

**Motor brake: Automatically activated after waiting time has elapsed [0x00b80004]**

Module ID (decimal)	Error ID (decimal)
184: Basic drive functions	4
<b>Reaction (Lenze setting in bold)</b>	
<input type="checkbox"/> None <input type="checkbox"/> System fault <input type="checkbox"/> Fault <input type="checkbox"/> Trouble <input type="checkbox"/> Quick stop by trouble <input type="checkbox"/> Warning locked <input type="checkbox"/> Warning <input checked="" type="checkbox"/> <b>Information</b>	
<b>Cause</b>	
This time monitoring will only be active if the speed setpoint has reached the threshold for brake activation ( <a href="#">C02581</a> ). If the actual speed value does not reach/fall below the threshold set in <a href="#">C02581</a> within the parameterised waiting time for brake activation ( <a href="#">C02593</a> ), the brake will be closed due to time-out.	<b>Remedy</b>
	<ul style="list-style-type: none"> <li>• Increase waiting time for brake activation (<a href="#">C02593</a>).</li> <li>• Reduce threshold for brake activation (<a href="#">C02581</a>).</li> </ul>

**Motor brake: Status monitoring error [0x00b80005]**

Module ID (decimal)	Error ID (decimal)
184: Basic drive functions	5
<b>Reaction</b> (Lenze setting in bold)	
<input type="checkbox"/> None <input type="checkbox"/> System fault <input type="checkbox"/> Fault <input type="checkbox"/> Trouble <input checked="" type="checkbox"/> <b>Quick stop by trouble</b> <input type="checkbox"/> Warning locked <input type="checkbox"/> Warning <input type="checkbox"/> Information	
<b>Cause</b>	<b>Remedy</b>
Faulty external feedback of the brake status to the brake control.	<ul style="list-style-type: none"> <li>• Check brake configuration with regard to the control selection in <a href="#">C02580</a>.</li> <li>• Check setting for status input monitoring in <a href="#">C02583</a>. When monitoring is active, the input <i>bBrakeApplied</i> must be triggered correctly (<i>bBrakeApplied</i> = <i>bBrakeReleased</i>).</li> <li>• Check voltage supply of the brake module.</li> </ul>

**Positive software limit switch overtravelled [0x00b80007]**

Module ID (decimal)	Error ID (decimal)
184: Basic drive functions	7
<b>Reaction</b> (Lenze setting in bold)	
Setting: <a href="#">C02716/2</a> ( <input checked="" type="checkbox"/> Adjustable response)	
<input checked="" type="checkbox"/> None <input type="checkbox"/> System fault <input checked="" type="checkbox"/> Fault <input checked="" type="checkbox"/> Trouble <input checked="" type="checkbox"/> <b>Quick stop by trouble</b> <input checked="" type="checkbox"/> Warning locked <input checked="" type="checkbox"/> Warning <input checked="" type="checkbox"/> Information	
<b>Cause</b>	<b>Remedy</b>
The positive software limit position parameterised in <a href="#">C02702/2</a> has been overtravelled.	<ul style="list-style-type: none"> <li>• Position within the software limit positions.</li> <li>• Increase permissible traversing range (change setting of the software limit positions).</li> <li>• Deactivate monitoring of the software limit positions by the basic function "Limiter".</li> </ul>

**Negative software limit switch overtravelled [0x00b80008]**

Module ID (decimal)	Error ID (decimal)
184: Basic drive functions	8
<b>Reaction</b> (Lenze setting in bold)	
Setting: <a href="#">C02716/2</a> ( <input checked="" type="checkbox"/> Adjustable response)	
<input checked="" type="checkbox"/> None <input type="checkbox"/> System fault <input checked="" type="checkbox"/> Fault <input checked="" type="checkbox"/> Trouble <input checked="" type="checkbox"/> <b>Quick stop by trouble</b> <input checked="" type="checkbox"/> Warning locked <input checked="" type="checkbox"/> Warning <input checked="" type="checkbox"/> Information	
<b>Cause</b>	<b>Remedy</b>
The negative software limit position parameterised in <a href="#">C02702/1</a> has been overtravelled.	<ul style="list-style-type: none"> <li>• Position within the software limit positions.</li> <li>• Increase permissible traversing range (change setting of the software limit positions).</li> <li>• Deactivate monitoring of the software limit positions by the basic function "Limiter".</li> </ul>

**Positive direction of rotation limited [0x00b80009]**

Module ID (decimal)	Error ID (decimal)
184: Basic drive functions	9
<b>Reaction</b> (Lenze setting in bold)	
Setting: <a href="#">C02716/1</a> ( <input checked="" type="checkbox"/> Adjustable response)	
<input checked="" type="checkbox"/> None <input type="checkbox"/> System fault <input checked="" type="checkbox"/> Fault <input checked="" type="checkbox"/> Trouble <input checked="" type="checkbox"/> <b>Quick stop by trouble</b> <input checked="" type="checkbox"/> Warning locked <input checked="" type="checkbox"/> Warning <input checked="" type="checkbox"/> <b>Information</b>	
<b>Cause</b>	<b>Remedy</b>
Due to the setting of <a href="#">C02707</a> it was tried to traverse in the impermissible positive direction of rotation.	<ul style="list-style-type: none"> <li>• Only traverse in permissible (negative) direction of rotation.</li> <li>• Change setting of the permissible direction of rotation (<a href="#">C02707</a>).</li> </ul>

### Negative direction of rotation limited [0x00b8000a]

Module ID (decimal)	Error ID (decimal)
184: Basic drive functions	10
<b>Reaction</b> (Lenze setting in bold)	<b>Setting:</b> <a href="#">C02716/1</a> ( <input checked="" type="checkbox"/> Adjustable response)
<input checked="" type="checkbox"/> None <input type="checkbox"/> System fault <input checked="" type="checkbox"/> Fault <input checked="" type="checkbox"/> Trouble <input checked="" type="checkbox"/> Quick stop by trouble <input checked="" type="checkbox"/> Warning locked <input checked="" type="checkbox"/> Warning <input checked="" type="checkbox"/> Information	
Cause	Remedy
Due to the setting of <a href="#">C02707</a> it was tried to traverse in the impermissible negative direction of rotation.	<ul style="list-style-type: none"> <li>• Only traverse in permissible (positive) direction of rotation.</li> <li>• Change setting of the permissible direction of rotation (<a href="#">C02707</a>).</li> </ul>

### Speed has been limited [0x00b8000b]

Module ID (decimal)	Error ID (decimal)
184: Basic drive functions	11
<b>Reaction</b> (Lenze setting in bold)	<b>Setting:</b> <a href="#">C02716/3</a> ( <input checked="" type="checkbox"/> Adjustable response)
<input checked="" type="checkbox"/> None <input type="checkbox"/> System fault <input checked="" type="checkbox"/> Fault <input checked="" type="checkbox"/> Trouble <input checked="" type="checkbox"/> Quick stop by trouble <input checked="" type="checkbox"/> Warning locked <input checked="" type="checkbox"/> Warning <input checked="" type="checkbox"/> Information	
Cause	Remedy
<ul style="list-style-type: none"> <li>• The requested profile speed is higher than the maximum speed set in <a href="#">C02703</a> and has been limited to this speed.</li> <li>• The required profile speed cannot be achieved with the motor reference speed set in <a href="#">C00011</a>.</li> </ul>	<ul style="list-style-type: none"> <li>• Reduce speed of the traversing profile of the basic function (manual jog, homing, or positioning).</li> <li>• Increase maximum speed (<a href="#">C02703</a>).</li> <li>• Deactivate monitoring of the limit values by the basic function "Limiter".</li> <li>• Set motor reference speed correctly (<a href="#">C00011</a>).</li> </ul>

### Acceleration has been limited [0x00b8000c]

Module ID (decimal)	Error ID (decimal)
184: Basic drive functions	12
<b>Reaction</b> (Lenze setting in bold)	<b>Setting:</b> <a href="#">C02716/3</a> ( <input checked="" type="checkbox"/> Adjustable response)
<input checked="" type="checkbox"/> None <input type="checkbox"/> System fault <input checked="" type="checkbox"/> Fault <input checked="" type="checkbox"/> Trouble <input checked="" type="checkbox"/> Quick stop by trouble <input checked="" type="checkbox"/> Warning locked <input checked="" type="checkbox"/> Warning <input checked="" type="checkbox"/> Information	
Cause	Remedy
The requested profile acceleration is higher than the maximum acceleration set in <a href="#">C02705</a> and has been limited to this acceleration.	<ul style="list-style-type: none"> <li>• Reduce acceleration of the traversing profile of the basic function (manual jog, homing, or positioning).</li> <li>• Increase maximum acceleration (<a href="#">C02705</a>).</li> <li>• Deactivate monitoring of the limit values by the basic function "Limiter".</li> </ul>

### Deceleration has been limited [0x00b8000d]

Module ID (decimal)	Error ID (decimal)
184: Basic drive functions	13
<b>Reaction</b> (Lenze setting in bold)	<b>Setting:</b> <a href="#">C02716/3</a> ( <input checked="" type="checkbox"/> Adjustable response)
<input checked="" type="checkbox"/> None <input type="checkbox"/> System fault <input checked="" type="checkbox"/> Fault <input checked="" type="checkbox"/> Trouble <input checked="" type="checkbox"/> Quick stop by trouble <input checked="" type="checkbox"/> Warning locked <input checked="" type="checkbox"/> Warning <input checked="" type="checkbox"/> Information	
Cause	Remedy
The requested profile deceleration is higher than the maximum acceleration set in <a href="#">C02705</a> and has been limited to this acceleration.	<ul style="list-style-type: none"> <li>• Reduce acceleration of the traversing profile of the basic function (manual jog, homing, or positioning).</li> <li>• Increase maximum acceleration (<a href="#">C02705</a>).</li> <li>• Deactivate monitoring of the limit values by the basic function "Limiter".</li> </ul>

## Jerk has been limited [0x00b8000e]

Module ID (decimal)	Error ID (decimal)
184: Basic drive functions	14
<b>Reaction</b> (Lenze setting in bold)	<b>Setting:</b> <a href="#">C02716/3</a> ( <input checked="" type="checkbox"/> Adjustable response)
<input checked="" type="checkbox"/> None <input type="checkbox"/> System fault <input checked="" type="checkbox"/> Fault <input checked="" type="checkbox"/> Trouble <input checked="" type="checkbox"/> Quick stop by trouble <input checked="" type="checkbox"/> Warning locked <input checked="" type="checkbox"/> Warning <input checked="" type="checkbox"/> <b>Information</b>	
Cause	Remedy
The requested S-ramp time is lower than the minimum S-ramp time set in <a href="#">C02706</a> and has been limited to this S-ramp time.	<ul style="list-style-type: none"> <li>• Increase S-ramp time of the traversing profile of the basic function (manual jog, homing, or positioning).</li> <li>• Reduce minimum S-ramp time (<a href="#">C02706</a>).</li> <li>• Deactivate monitoring of the limit values by the basic function "Limiter".</li> </ul>

## Position target outside the software limit positions [0x00b8000f]

Module ID (decimal)	Error ID (decimal)
184: Basic drive functions	15
<b>Reaction</b> (Lenze setting in bold)	<b>Setting:</b> <a href="#">C02716/2</a> ( <input checked="" type="checkbox"/> Adjustable response)
<input checked="" type="checkbox"/> None <input type="checkbox"/> System fault <input checked="" type="checkbox"/> Fault <input checked="" type="checkbox"/> Trouble <input checked="" type="checkbox"/> <b>Quick stop by trouble</b> <input checked="" type="checkbox"/> Warning locked <input checked="" type="checkbox"/> Warning <input checked="" type="checkbox"/> Information	
Cause	Remedy
It was tried to position to a target outside the software limit positions.	<ul style="list-style-type: none"> <li>• Select a target within the software limit positions.</li> <li>• Increase permissible traversing range (change setting of the software limit positions).</li> <li>• Deactivate monitoring of the software limit positions by the basic function "Limiter".</li> </ul>

## Maximum speed exceeded [0x00b80010]

Module ID (decimal)	Error ID (decimal)
184: Basic drive functions	16
<b>Reaction</b> (Lenze setting in bold)	<b>Setting:</b> <a href="#">C02716/3</a> ( <input checked="" type="checkbox"/> Adjustable response)
<input checked="" type="checkbox"/> None <input type="checkbox"/> System fault <input checked="" type="checkbox"/> Fault <input checked="" type="checkbox"/> Trouble <input checked="" type="checkbox"/> Quick stop by trouble <input checked="" type="checkbox"/> Warning locked <input checked="" type="checkbox"/> Warning <input checked="" type="checkbox"/> <b>Information</b>	
Cause	Remedy
The max. speed parameterised in <a href="#">C02703</a> or <a href="#">C00011</a> has been exceeded.	<ul style="list-style-type: none"> <li>• Reduce speed.</li> <li>• Increase maximum speed (<a href="#">C02703</a>).</li> <li>• Deactivate monitoring of the limit values by the basic function "Limiter".</li> </ul>

## Maximum acceleration exceeded [0x00b80011]

Module ID (decimal)	Error ID (decimal)
184: Basic drive functions	17
<b>Reaction</b> (Lenze setting in bold)	<b>Setting:</b> <a href="#">C02716/3</a> ( <input checked="" type="checkbox"/> Adjustable response)
<input checked="" type="checkbox"/> None <input type="checkbox"/> System fault <input checked="" type="checkbox"/> Fault <input checked="" type="checkbox"/> Trouble <input checked="" type="checkbox"/> Quick stop by trouble <input checked="" type="checkbox"/> Warning locked <input checked="" type="checkbox"/> Warning <input checked="" type="checkbox"/> <b>Information</b>	
Cause	Remedy
The max. acceleration parameterised in <a href="#">C02705</a> has been exceeded.	<ul style="list-style-type: none"> <li>• Reduce acceleration.</li> <li>• Increase maximum acceleration (<a href="#">C02705</a>).</li> <li>• Deactivate monitoring of the limit values by the basic function "Limiter".</li> </ul>



## Time-out torque feedforward control - brake [0x00b80012]

Module ID (decimal)	Error ID (decimal)
184: Basic drive functions	18
<b>Reaction</b> (Lenze setting in bold)	
<input type="checkbox"/> None <input type="checkbox"/> System fault <input type="checkbox"/> Fault <input type="checkbox"/> Trouble <input checked="" type="checkbox"/> <b>Quick stop by trouble</b> <input type="checkbox"/> Warning locked <input type="checkbox"/> Warning <input type="checkbox"/> Information	
<b>Cause</b>	<b>Remedy</b>
After 1 second the actual torque has not yet reached 90 % of the precontrolled setpoint torque for releasing the brake.	Check settings for torque feedforward control. <ul style="list-style-type: none"> <li>• Possibly the maximum current (<a href="#">C00022</a>) is not sufficient for the required torque feedforward control.</li> </ul>

## Cam data: Serial number MM does not match [0x00b80013]

Module ID (decimal)	Error ID (decimal)
184: Basic drive functions	19
<b>Reaction</b> (Lenze setting in bold)	
<input type="checkbox"/> None <input type="checkbox"/> System fault <input type="checkbox"/> Fault <input type="checkbox"/> Trouble <input type="checkbox"/> Quick stop by trouble <input checked="" type="checkbox"/> <b>Warning locked</b> <input type="checkbox"/> Warning <input type="checkbox"/> Information	
<b>Cause</b>	<b>Remedy</b>
The cam data are provided with an access protection of level 3 (linkage to the memory module), and the serial number contained in the cam data does not correspond to the serial number of the memory module.	Check and, if required, correct the serial number entered in »Cam Designer«. Afterwards redownload the cam data.

## Cam data are corrupted [0x00b80014]

Module ID (decimal)	Error ID (decimal)
184: Basic drive functions	20
<b>Reaction</b> (Lenze setting in bold)	
<input type="checkbox"/> None <input type="checkbox"/> System fault <input type="checkbox"/> Fault <input type="checkbox"/> Trouble <input type="checkbox"/> Quick stop by trouble <input checked="" type="checkbox"/> <b>Warning locked</b> <input type="checkbox"/> Warning <input type="checkbox"/> Information	
<b>Cause</b>	<b>Remedy</b>
Checksum error during reading the file, or the password was manipulated.	Redownload cam data.

## Cam data restored [0x00b80015]

Module ID (decimal)	Error ID (decimal)
184: Basic drive functions	21
<b>Reaction</b> (Lenze setting in bold)	
<input type="checkbox"/> None <input type="checkbox"/> System fault <input checked="" type="checkbox"/> <b>Fault</b> <input type="checkbox"/> Trouble <input type="checkbox"/> Quick stop by trouble <input type="checkbox"/> Warning locked <input type="checkbox"/> Warning <input type="checkbox"/> Information	
<b>Cause</b>	<b>Remedy</b>
The last download of the cam data was faulty or has not been completed successfully. The previous cam data – if available – have been downloaded from the backup file.	<ul style="list-style-type: none"> <li>• Redownload cam data.</li> <li>• Save cam data within the controller in the memory module via device command <a href="#">C00002</a> = "502: Save cam data".</li> </ul>

## Cam data locked due to incorrect password [0x00b80016]

Module ID (decimal)	Error ID (decimal)
184: Basic drive functions	22
<b>Reaction</b> (Lenze setting in bold)	
<input type="checkbox"/> None <input type="checkbox"/> System fault <input type="checkbox"/> Fault <input type="checkbox"/> Trouble <input type="checkbox"/> Quick stop by trouble <input checked="" type="checkbox"/> <b>Warning locked</b> <input type="checkbox"/> Warning <input type="checkbox"/> Information	
<b>Cause</b>	<b>Remedy</b>
The cam data were locked since the user password was entered incorrectly for three times. The cam data were not loaded.	Reset parameters to the Lenze setting via device command <a href="#">C00002</a> = "0: Load Lenze setting". Then download cam data again.

## Cam data locked due to incorrect safety key [0x00b80017]

Module ID (decimal)	Error ID (decimal)
184: Basic drive functions	23
<b>Reaction</b> (Lenze setting in bold)	
<input type="checkbox"/> None <input type="checkbox"/> System fault <input type="checkbox"/> Fault <input type="checkbox"/> Trouble <input type="checkbox"/> Quick stop by trouble <input checked="" type="checkbox"/> <b>Warning locked</b> <input type="checkbox"/> Warning <input type="checkbox"/> Information	
<b>Cause</b>	<b>Remedy</b>
The cam data were not loaded because the safety key is damaged. The password in the cam data or the serial number of the memory module has been manipulated.	Reset parameters to the Lenze setting via device command <a href="#">C00002</a> = "0: Load Lenze setting". Then download cam data again.

## Homing mode not allowed [0x00b80019]

Module ID (decimal)	Error ID (decimal)
184: Basic drive functions	25
<b>Reaction</b> (Lenze setting in bold)	
<input type="checkbox"/> None <input type="checkbox"/> System fault <input checked="" type="checkbox"/> <b>Fault</b> <input type="checkbox"/> Trouble <input type="checkbox"/> Quick stop by trouble <input type="checkbox"/> Warning locked <input type="checkbox"/> Warning <input type="checkbox"/> Information	
<b>Cause</b>	<b>Remedy</b>
<a href="#">From software version V3.0</a> The homing mode selected in <a href="#">C02640</a> is not supported in the motor control type selected in <a href="#">C00006</a> .	Select another homing mode in <a href="#">C02640</a> .

## Int. overflow C02620 (manual jog: Speed 1) [0x00b8001a]

Module ID (decimal)	Error ID (decimal)
184: Basic drive functions	26
<b>Reaction</b> (Lenze setting in bold)	
<input type="checkbox"/> None <input type="checkbox"/> System fault <input checked="" type="checkbox"/> <b>Fault</b> <input type="checkbox"/> Trouble <input type="checkbox"/> Quick stop by trouble <input type="checkbox"/> Warning locked <input type="checkbox"/> Warning <input type="checkbox"/> Information	
<b>Cause</b>	<b>Remedy</b>
<a href="#">From software version V3.0</a> Due to a subsequent change of the machine parameters for gearbox ratio, feed constant, or resolution of an encoder revolution, the value set in the parameter cannot be displayed in the internal unit. See chapter " <a href="#">Max. position, speed, and acceleration that can be displayed internally</a> ".	<ul style="list-style-type: none"> <li>• Check machine parameters and adapt them if required.</li> <li>• Change setting in <a href="#">C02620</a>.</li> </ul>

## Int. overflow C02621 (manual jog: Speed 2) [0x00b8001b]

Module ID (decimal)	Error ID (decimal)
184: Basic drive functions	27
<b>Reaction</b> (Lenze setting in bold)	
<input type="checkbox"/> None <input type="checkbox"/> System fault <input checked="" type="checkbox"/> <b>Fault</b> <input type="checkbox"/> Trouble <input type="checkbox"/> Quick stop by trouble <input type="checkbox"/> Warning locked <input type="checkbox"/> Warning <input type="checkbox"/> Information	
<b>Cause</b>	<b>Remedy</b>
<p><a href="#">From software version V3.0</a>          Due to a subsequent change of the machine parameters for gearbox ratio, feed constant, or resolution of an encoder revolution, the value set in the parameter cannot be displayed in the internal unit. See chapter "<a href="#">Max. position, speed, and acceleration that can be displayed internally</a>".</p>	<ul style="list-style-type: none"> <li>• Check machine parameters and adapt them if required.</li> <li>• Change setting in <a href="#">C02621</a>.</li> </ul>

## Int. overflow C02622 (manual jog: Acceleration) [0x00b8001c]

Module ID (decimal)	Error ID (decimal)
184: Basic drive functions	28
<b>Reaction</b> (Lenze setting in bold)	
<input type="checkbox"/> None <input type="checkbox"/> System fault <input checked="" type="checkbox"/> <b>Fault</b> <input type="checkbox"/> Trouble <input type="checkbox"/> Quick stop by trouble <input type="checkbox"/> Warning locked <input type="checkbox"/> Warning <input type="checkbox"/> Information	
<b>Cause</b>	<b>Remedy</b>
<p><a href="#">From software version V3.0</a>          Due to a subsequent change of the machine parameters for gearbox ratio, feed constant, or resolution of an encoder revolution, the value set in the parameter cannot be displayed in the internal unit. See chapter "<a href="#">Max. position, speed, and acceleration that can be displayed internally</a>".</p>	<ul style="list-style-type: none"> <li>• Check machine parameters and adapt them if required.</li> <li>• Change setting in <a href="#">C02622</a>.</li> </ul>

## Int. overflow C02623 (manual jog: Deceleration) [0x00b8001d]

Module ID (decimal)	Error ID (decimal)
184: Basic drive functions	29
<b>Reaction</b> (Lenze setting in bold)	
<input type="checkbox"/> None <input type="checkbox"/> System fault <input checked="" type="checkbox"/> <b>Fault</b> <input type="checkbox"/> Trouble <input type="checkbox"/> Quick stop by trouble <input type="checkbox"/> Warning locked <input type="checkbox"/> Warning <input type="checkbox"/> Information	
<b>Cause</b>	<b>Remedy</b>
<p><a href="#">From software version V3.0</a>          Due to a subsequent change of the machine parameters for gearbox ratio, feed constant, or resolution of an encoder revolution, the value set in the parameter cannot be displayed in the internal unit. See chapter "<a href="#">Max. position, speed, and acceleration that can be displayed internally</a>".</p>	<ul style="list-style-type: none"> <li>• Check machine parameters and adapt them if required.</li> <li>• Change setting in <a href="#">C02623</a>.</li> </ul>

## Int. overflow C02701/1 (positive software limit position) [0x00b80020]

Module ID (decimal)	Error ID (decimal)
184: Basic drive functions	32
<b>Reaction</b> (Lenze setting in bold)	
<input type="checkbox"/> None <input type="checkbox"/> System fault <input checked="" type="checkbox"/> <b>Fault</b> <input type="checkbox"/> Trouble <input type="checkbox"/> Quick stop by trouble <input type="checkbox"/> Warning locked <input type="checkbox"/> Warning <input type="checkbox"/> Information	
<b>Cause</b>	<b>Remedy</b>
<p><a href="#">From software version V3.0</a>          Due to a subsequent change of the machine parameters for gearbox ratio, feed constant, or resolution of an encoder revolution, the value set in the parameter cannot be displayed in the internal unit. See chapter "<a href="#">Max. position, speed, and acceleration that can be displayed internally</a>".</p>	<ul style="list-style-type: none"> <li>• Check machine parameters and adapt them if required.</li> <li>• Change setting in <a href="#">C02701/1</a>.</li> </ul>

## Int. overflow C02701/2 (negative software limit position) [0x00b80021]

Module ID (decimal)	Error ID (decimal)
184: Basic drive functions	33
<b>Reaction</b> (Lenze setting in bold)	
<input type="checkbox"/> None <input type="checkbox"/> System fault <input checked="" type="checkbox"/> <b>Fault</b> <input type="checkbox"/> Trouble <input type="checkbox"/> Quick stop by trouble <input type="checkbox"/> Warning locked <input type="checkbox"/> Warning <input type="checkbox"/> Information	
<b>Cause</b>	<b>Remedy</b>
<p><a href="#">From software version V3.0</a>          Due to a subsequent change of the machine parameters for gearbox ratio, feed constant, or resolution of an encoder revolution, the value set in the parameter cannot be displayed in the internal unit. See chapter "<a href="#">Max. position, speed, and acceleration that can be displayed internally</a>".</p>	<ul style="list-style-type: none"> <li>• Check machine parameters and adapt them if required.</li> <li>• Change setting in <a href="#">C02701/2</a>.</li> </ul>

## Int. overflow C02703 (maximum speed) [0x00b80022]

Module ID (decimal)	Error ID (decimal)
184: Basic drive functions	34
<b>Reaction</b> (Lenze setting in bold)	
<input type="checkbox"/> None <input type="checkbox"/> System fault <input checked="" type="checkbox"/> <b>Fault</b> <input type="checkbox"/> Trouble <input type="checkbox"/> Quick stop by trouble <input type="checkbox"/> Warning locked <input type="checkbox"/> Warning <input type="checkbox"/> Information	
<b>Cause</b>	<b>Remedy</b>
<p><a href="#">From software version V3.0</a>          Due to a subsequent change of the machine parameters for gearbox ratio, feed constant, or resolution of an encoder revolution, the value set in the parameter cannot be displayed in the internal unit. See chapter "<a href="#">Max. position, speed, and acceleration that can be displayed internally</a>".</p>	<ul style="list-style-type: none"> <li>• Check machine parameters and adapt them if required.</li> <li>• Change setting in <a href="#">C02703</a>.</li> </ul>

## Int. overflow C02705 (maximum acceleration) [0x00b80023]

Module ID (decimal)	Error ID (decimal)
184: Basic drive functions	35
<b>Reaction</b> (Lenze setting in bold)	
<input type="checkbox"/> None <input type="checkbox"/> System fault <input checked="" type="checkbox"/> <b>Fault</b> <input type="checkbox"/> Trouble <input type="checkbox"/> Quick stop by trouble <input type="checkbox"/> Warning locked <input type="checkbox"/> Warning <input type="checkbox"/> Information	
<b>Cause</b>	<b>Remedy</b>
<p><a href="#">From software version V3.0</a>  Due to a subsequent change of the machine parameters for gearbox ratio, feed constant, or resolution of an encoder revolution, the value set in the parameter cannot be displayed in the internal unit. See chapter "<a href="#">Max. position, speed, and acceleration that can be displayed internally</a>".</p>	<ul style="list-style-type: none"> <li>• Check machine parameters and adapt them if required.</li> <li>• Change setting in <a href="#">C02705</a>.</li> </ul>

## Int. overflow C02708/1 (limited speed 1) [0x00b80024]

Module ID (decimal)	Error ID (decimal)
184: Basic drive functions	36
<b>Reaction</b> (Lenze setting in bold)	
<input type="checkbox"/> None <input type="checkbox"/> System fault <input checked="" type="checkbox"/> <b>Fault</b> <input type="checkbox"/> Trouble <input type="checkbox"/> Quick stop by trouble <input type="checkbox"/> Warning locked <input type="checkbox"/> Warning <input type="checkbox"/> Information	
<b>Cause</b>	<b>Remedy</b>
<p><a href="#">From software version V3.0</a>  Due to a subsequent change of the machine parameters for gearbox ratio, feed constant, or resolution of an encoder revolution, the value set in the parameter cannot be displayed in the internal unit. See chapter "<a href="#">Max. position, speed, and acceleration that can be displayed internally</a>".</p>	<ul style="list-style-type: none"> <li>• Check machine parameters and adapt them if required.</li> <li>• Change setting in <a href="#">C02708/1</a>.</li> </ul>

## Int. overflow C02708/2 (limited speed 2) [0x00b80025]

Module ID (decimal)	Error ID (decimal)
184: Basic drive functions	37
<b>Reaction</b> (Lenze setting in bold)	
<input type="checkbox"/> None <input type="checkbox"/> System fault <input checked="" type="checkbox"/> <b>Fault</b> <input type="checkbox"/> Trouble <input type="checkbox"/> Quick stop by trouble <input type="checkbox"/> Warning locked <input type="checkbox"/> Warning <input type="checkbox"/> Information	
<b>Cause</b>	<b>Remedy</b>
<p><a href="#">From software version V3.0</a>  Due to a subsequent change of the machine parameters for gearbox ratio, feed constant, or resolution of an encoder revolution, the value set in the parameter cannot be displayed in the internal unit. See chapter "<a href="#">Max. position, speed, and acceleration that can be displayed internally</a>".</p>	<ul style="list-style-type: none"> <li>• Check machine parameters and adapt them if required.</li> <li>• Change setting in <a href="#">C02708/2</a>.</li> </ul>

## Int. overflow C02708/3 (limited speed 3) [0x00b80026]

Module ID (decimal)	Error ID (decimal)
184: Basic drive functions	38
<b>Reaction</b> (Lenze setting in bold)	
<input type="checkbox"/> None <input type="checkbox"/> System fault <input checked="" type="checkbox"/> <b>Fault</b> <input type="checkbox"/> Trouble <input type="checkbox"/> Quick stop by trouble <input type="checkbox"/> Warning locked <input type="checkbox"/> Warning <input type="checkbox"/> Information	
<b>Cause</b>	<b>Remedy</b>
<p><a href="#">From software version V3.0</a>            Due to a subsequent change of the machine parameters for gearbox ratio, feed constant, or resolution of an encoder revolution, the value set in the parameter cannot be displayed in the internal unit. See chapter "<a href="#">Max. position, speed, and acceleration that can be displayed internally</a>".</p>	<ul style="list-style-type: none"> <li>• Check machine parameters and adapt them if required.</li> <li>• Change setting in <a href="#">C02708/3</a>.</li> </ul>

## Int. overflow C02708/4 (limited speed 4) [0x00b80027]

Module ID (decimal)	Error ID (decimal)
184: Basic drive functions	39
<b>Reaction</b> (Lenze setting in bold)	
<input type="checkbox"/> None <input type="checkbox"/> System fault <input checked="" type="checkbox"/> <b>Fault</b> <input type="checkbox"/> Trouble <input type="checkbox"/> Quick stop by trouble <input type="checkbox"/> Warning locked <input type="checkbox"/> Warning <input type="checkbox"/> Information	
<b>Cause</b>	<b>Remedy</b>
<p><a href="#">From software version V3.0</a>            Due to a subsequent change of the machine parameters for gearbox ratio, feed constant, or resolution of an encoder revolution, the value set in the parameter cannot be displayed in the internal unit. See chapter "<a href="#">Max. position, speed, and acceleration that can be displayed internally</a>".</p>	<ul style="list-style-type: none"> <li>• Check machine parameters and adapt them if required.</li> <li>• Change setting in <a href="#">C02708/4</a>.</li> </ul>

## Int. overflow C02708/1 (decel. limited speed 1) [0x00b80028]

Module ID (decimal)	Error ID (decimal)
184: Basic drive functions	40
<b>Reaction</b> (Lenze setting in bold)	
<input type="checkbox"/> None <input type="checkbox"/> System fault <input checked="" type="checkbox"/> <b>Fault</b> <input type="checkbox"/> Trouble <input type="checkbox"/> Quick stop by trouble <input type="checkbox"/> Warning locked <input type="checkbox"/> Warning <input type="checkbox"/> Information	
<b>Cause</b>	<b>Remedy</b>
<p><a href="#">From software version V3.0</a>            Due to a subsequent change of the machine parameters for gearbox ratio, feed constant, or resolution of an encoder revolution, the value set in the parameter cannot be displayed in the internal unit. See chapter "<a href="#">Max. position, speed, and acceleration that can be displayed internally</a>".</p>	<ul style="list-style-type: none"> <li>• Check machine parameters and adapt them if required.</li> <li>• Change setting in <a href="#">C02710/1</a>.</li> </ul>

## Int. overflow C02708/2 (decel. limited speed 2) [0x00b80029]

Module ID (decimal)	Error ID (decimal)
184: Basic drive functions	41
<b>Reaction</b> (Lenze setting in bold)	
<input type="checkbox"/> None <input type="checkbox"/> System fault <input checked="" type="checkbox"/> <b>Fault</b> <input type="checkbox"/> Trouble <input type="checkbox"/> Quick stop by trouble <input type="checkbox"/> Warning locked <input type="checkbox"/> Warning <input type="checkbox"/> Information	
<b>Cause</b>	<b>Remedy</b>
<p><a href="#">From software version V3.0</a>          Due to a subsequent change of the machine parameters for gearbox ratio, feed constant, or resolution of an encoder revolution, the value set in the parameter cannot be displayed in the internal unit. See chapter "<a href="#">Max. position, speed, and acceleration that can be displayed internally</a>".</p>	<ul style="list-style-type: none"> <li>• Check machine parameters and adapt them if required.</li> <li>• Change setting in <a href="#">C02710/2</a>.</li> </ul>

## Int. overflow C02708/3 (decel. limited speed 3) [0x00b8002a]

Module ID (decimal)	Error ID (decimal)
184: Basic drive functions	42
<b>Reaction</b> (Lenze setting in bold)	
<input type="checkbox"/> None <input type="checkbox"/> System fault <input checked="" type="checkbox"/> <b>Fault</b> <input type="checkbox"/> Trouble <input type="checkbox"/> Quick stop by trouble <input type="checkbox"/> Warning locked <input type="checkbox"/> Warning <input type="checkbox"/> Information	
<b>Cause</b>	<b>Remedy</b>
<p><a href="#">From software version V3.0</a>          Due to a subsequent change of the machine parameters for gearbox ratio, feed constant, or resolution of an encoder revolution, the value set in the parameter cannot be displayed in the internal unit. See chapter "<a href="#">Max. position, speed, and acceleration that can be displayed internally</a>".</p>	<ul style="list-style-type: none"> <li>• Check machine parameters and adapt them if required.</li> <li>• Change setting in <a href="#">C02710/3</a>.</li> </ul>

## Int. overflow C02708/4 (decel. limited speed 4) [0x00b8002b]

Module ID (decimal)	Error ID (decimal)
184: Basic drive functions	43
<b>Reaction</b> (Lenze setting in bold)	
<input type="checkbox"/> None <input type="checkbox"/> System fault <input checked="" type="checkbox"/> <b>Fault</b> <input type="checkbox"/> Trouble <input type="checkbox"/> Quick stop by trouble <input type="checkbox"/> Warning locked <input type="checkbox"/> Warning <input type="checkbox"/> Information	
<b>Cause</b>	<b>Remedy</b>
<p><a href="#">From software version V3.0</a>          Due to a subsequent change of the machine parameters for gearbox ratio, feed constant, or resolution of an encoder revolution, the value set in the parameter cannot be displayed in the internal unit. See chapter "<a href="#">Max. position, speed, and acceleration that can be displayed internally</a>".</p>	<ul style="list-style-type: none"> <li>• Check machine parameters and adapt them if required.</li> <li>• Change setting in <a href="#">C02710/4</a>.</li> </ul>

## Int. overflow C02713 (max. dist. manual control) [0x00b8002c]

Module ID (decimal)	Error ID (decimal)
184: Basic drive functions	44
<b>Reaction</b> (Lenze setting in bold)	
<input type="checkbox"/> None <input type="checkbox"/> System fault <input checked="" type="checkbox"/> <b>Fault</b> <input type="checkbox"/> Trouble <input type="checkbox"/> Quick stop by trouble <input type="checkbox"/> Warning locked <input type="checkbox"/> Warning <input type="checkbox"/> Information	
<b>Cause</b>	<b>Remedy</b>
<p><a href="#">From software version V3.0</a>            Due to a subsequent change of the machine parameters for gearbox ratio, feed constant, or resolution of an encoder revolution, the value set in the parameter cannot be displayed in the internal unit. See chapter "<a href="#">Max. position, speed, and acceleration that can be displayed internally</a>".</p>	<ul style="list-style-type: none"> <li>• Check machine parameters and adapt them if required.</li> <li>• Change setting in <a href="#">C02713</a>.</li> </ul>

## Int. overflow C02642 (home position) [0x00b8002d]

Module ID (decimal)	Error ID (decimal)
184: Basic drive functions	45
<b>Reaction</b> (Lenze setting in bold)	
<input type="checkbox"/> None <input type="checkbox"/> System fault <input checked="" type="checkbox"/> <b>Fault</b> <input type="checkbox"/> Trouble <input type="checkbox"/> Quick stop by trouble <input type="checkbox"/> Warning locked <input type="checkbox"/> Warning <input type="checkbox"/> Information	
<b>Cause</b>	<b>Remedy</b>
<p><a href="#">From software version V3.0</a>            Due to a subsequent change of the machine parameters for gearbox ratio, feed constant, or resolution of an encoder revolution, the value set in the parameter cannot be displayed in the internal unit. See chapter "<a href="#">Max. position, speed, and acceleration that can be displayed internally</a>".</p>	<ul style="list-style-type: none"> <li>• Check machine parameters and adapt them if required.</li> <li>• Change setting in <a href="#">C02642</a>.</li> </ul>

## Int. overflow C02643 (homing: Target position) [0x00b8002e]

Module ID (decimal)	Error ID (decimal)
184: Basic drive functions	46
<b>Reaction</b> (Lenze setting in bold)	
<input type="checkbox"/> None <input type="checkbox"/> System fault <input checked="" type="checkbox"/> <b>Fault</b> <input type="checkbox"/> Trouble <input type="checkbox"/> Quick stop by trouble <input type="checkbox"/> Warning locked <input type="checkbox"/> Warning <input type="checkbox"/> Information	
<b>Cause</b>	<b>Remedy</b>
<p><a href="#">From software version V3.0</a>            Due to a subsequent change of the machine parameters for gearbox ratio, feed constant, or resolution of an encoder revolution, the value set in the parameter cannot be displayed in the internal unit. See chapter "<a href="#">Max. position, speed, and acceleration that can be displayed internally</a>".</p>	<ul style="list-style-type: none"> <li>• Check machine parameters and adapt them if required.</li> <li>• Change setting in <a href="#">C02643</a>.</li> </ul>



## Int. overflow C02644 (homing: Speed 1) [0x00b8002f]

Module ID (decimal)	Error ID (decimal)
184: Basic drive functions	47
<b>Reaction</b> (Lenze setting in bold)	
<input type="checkbox"/> None <input type="checkbox"/> System fault <input checked="" type="checkbox"/> <b>Fault</b> <input type="checkbox"/> Trouble <input type="checkbox"/> Quick stop by trouble <input type="checkbox"/> Warning locked <input type="checkbox"/> Warning <input type="checkbox"/> Information	
<b>Cause</b>	<b>Remedy</b>
<p><a href="#">From software version V3.0</a>          Due to a subsequent change of the machine parameters for gearbox ratio, feed constant, or resolution of an encoder revolution, the value set in the parameter cannot be displayed in the internal unit. See chapter "<a href="#">Max. position, speed, and acceleration that can be displayed internally</a>".</p>	<ul style="list-style-type: none"> <li>• Check machine parameters and adapt them if required.</li> <li>• Change setting in <a href="#">C02644</a>.</li> </ul>

## Int. overflow C02645 (homing: Acceleration 1) [0x00b80030]

Module ID (decimal)	Error ID (decimal)
184: Basic drive functions	48
<b>Reaction</b> (Lenze setting in bold)	
<input type="checkbox"/> None <input type="checkbox"/> System fault <input checked="" type="checkbox"/> <b>Fault</b> <input type="checkbox"/> Trouble <input type="checkbox"/> Quick stop by trouble <input type="checkbox"/> Warning locked <input type="checkbox"/> Warning <input type="checkbox"/> Information	
<b>Cause</b>	<b>Remedy</b>
<p><a href="#">From software version V3.0</a>          Due to a subsequent change of the machine parameters for gearbox ratio, feed constant, or resolution of an encoder revolution, the value set in the parameter cannot be displayed in the internal unit. See chapter "<a href="#">Max. position, speed, and acceleration that can be displayed internally</a>".</p>	<ul style="list-style-type: none"> <li>• Check machine parameters and adapt them if required.</li> <li>• Change setting in <a href="#">C02645</a>.</li> </ul>

## Int. overflow C02646 (homing: Speed 2) [0x00b80031]

Module ID (decimal)	Error ID (decimal)
184: Basic drive functions	49
<b>Reaction</b> (Lenze setting in bold)	
<input type="checkbox"/> None <input type="checkbox"/> System fault <input checked="" type="checkbox"/> <b>Fault</b> <input type="checkbox"/> Trouble <input type="checkbox"/> Quick stop by trouble <input type="checkbox"/> Warning locked <input type="checkbox"/> Warning <input type="checkbox"/> Information	
<b>Cause</b>	<b>Remedy</b>
<p><a href="#">From software version V3.0</a>          Due to a subsequent change of the machine parameters for gearbox ratio, feed constant, or resolution of an encoder revolution, the value set in the parameter cannot be displayed in the internal unit. See chapter "<a href="#">Max. position, speed, and acceleration that can be displayed internally</a>".</p>	<ul style="list-style-type: none"> <li>• Check machine parameters and adapt them if required.</li> <li>• Change setting in <a href="#">C02646</a>.</li> </ul>

**Int. overflow C02647 (homing: Acceleration 2) [0x00b80032]**

Module ID (decimal)	Error ID (decimal)
184: Basic drive functions	50
<b>Reaction</b> (Lenze setting in bold)	
<input type="checkbox"/> None <input type="checkbox"/> System fault <input checked="" type="checkbox"/> <b>Fault</b> <input type="checkbox"/> Trouble <input type="checkbox"/> Quick stop by trouble <input type="checkbox"/> Warning locked <input type="checkbox"/> Warning <input type="checkbox"/> Information	
<b>Cause</b>	<b>Remedy</b>
<p><a href="#">From software version V3.0</a>          Due to a subsequent change of the machine parameters for gearbox ratio, feed constant, or resolution of an encoder revolution, the value set in the parameter cannot be displayed in the internal unit. See chapter "<a href="#">Max. position, speed, and acceleration that can be displayed internally</a>".</p>	<ul style="list-style-type: none"> <li>• Check machine parameters and adapt them if required.</li> <li>• Change setting in <a href="#">C02647</a>.</li> </ul>

**Int. overflow C02670 (positioner: Tol. for target position) [0x00b80033]**

Module ID (decimal)	Error ID (decimal)
184: Basic drive functions	51
<b>Reaction</b> (Lenze setting in bold)	
<input type="checkbox"/> None <input type="checkbox"/> System fault <input checked="" type="checkbox"/> <b>Fault</b> <input type="checkbox"/> Trouble <input type="checkbox"/> Quick stop by trouble <input type="checkbox"/> Warning locked <input type="checkbox"/> Warning <input type="checkbox"/> Information	
<b>Cause</b>	<b>Remedy</b>
<p><a href="#">From software version V3.0</a>          Due to a subsequent change of the machine parameters for gearbox ratio, feed constant, or resolution of an encoder revolution, the value set in the parameter cannot be displayed in the internal unit. See chapter "<a href="#">Max. position, speed, and acceleration that can be displayed internally</a>".</p>	<ul style="list-style-type: none"> <li>• Check machine parameters and adapt them if required.</li> <li>• Change setting in <a href="#">C02670</a>.</li> </ul>

**Cam data: Invalidated due to change of mechanical data [0x00b80034]**

Module ID (decimal)	Error ID (decimal)
184: Basic drive functions	52
<b>Reaction</b> (Lenze setting in bold)	
<input type="checkbox"/> None <input type="checkbox"/> System fault <input type="checkbox"/> Fault <input type="checkbox"/> Trouble <input type="checkbox"/> Quick stop by trouble <input type="checkbox"/> Warning locked <input checked="" type="checkbox"/> <b>Warning</b> <input type="checkbox"/> Information	
<b>Cause</b>	<b>Remedy</b>
<p><a href="#">From software version V4.0</a>          One or several machine parameters have been changed that have an influence on the internal scaling of the Cam data. The Cam data has to be recalculated. See chapter "<a href="#">Invalid Cam data due to changed machine parameters</a>".</p>	<p>Execute device command <a href="#">C00002</a> = "503: Calculate Cam Data". This automatically resets the warning.</p>

---

**Cam data: invalid product number [0x00b80035]**

Module ID (decimal)	Error ID (decimal)
184: Basic drive functions	53
Reaction (Lenze setting in bold)	
<input type="checkbox"/> None <input type="checkbox"/> System fault <input type="checkbox"/> Fault <input type="checkbox"/> Trouble <input type="checkbox"/> Quick stop by trouble <input type="checkbox"/> Warning locked <input type="checkbox"/> Warning <input checked="" type="checkbox"/> <b>Information</b>	
Cause	Remedy
<p><b>From software version V5.0</b></p> <p>A product number has been created in the system block <a href="#">LS_CamInterface</a> which is not in the range of product number of the downloaded cam data.</p>	<p>Check number of products.</p> <ul style="list-style-type: none"> <li>• The product number must be higher than 0 and lower than the value displayed in <a href="#">C02908</a>.</li> <li>• <a href="#">C02908</a> displays the highest product number +1 of the cam data currently being processed.</li> </ul>

### 14 Parameter reference

All parameters for controller parameterising or monitoring are saved as "codes".

- The codes are numbered and indicated by the prefix "C" before the code, e.g. "C00002".
- For the sake of clarity, some codes contain "subcodes" for saving parameters. This Manual uses a slash "/" as a separator between code and subcode, e.g. C00118/3".

---

Parameters available in the controller only from a certain software version are marked accordingly ("From software version Vx.x").

The parameter descriptions are based on the software version V15.00.xx.

---



#### Tip!

For quick reference of a parameter with a certain name simply use the **index** of the online documentation. The index always contains the corresponding code in parentheses behind the name.

For general information on how to read and change parameters, please see the online documentation for the »Engineer«.

# 14 Parameter reference

## 14.1 Structure of the parameter descriptions

---

### 14.1 Structure of the parameter descriptions

Each parameter is described in the [Parameter list](#) in the form of a table which consists of the following three areas:

#### Table header

The table header contains the following general information:

- Parameter number (Cxxxxx)
- Parameter name (display text in the »Engineer« and keypad)
- [Data type](#)
- Decimal and hexadecimal parameter index for access via bus systems

#### Table contents

The table contains further general explanations & notes on the parameter and the possible settings, which are represented in different ways depending on the parameter type:

- [Parameters with read-only access](#)
- [Parameters with write access](#)

#### Table footer

The table footer contains the [Parameter attributes](#).

#### 14.1.1 Data type

The following data types are available for parameters:

Data type	Meaning
INTEGER_8	8-bit value with sign
INTEGER_16	16-bit value with sign
INTEGER_32	32-bit value with sign
INTEGER_64	64-bit value with sign
UNSIGNED_8	8-bit value without sign
UNSIGNED_16	16-bit value without sign
UNSIGNED_32	32-bit value without sign
UNSIGNED_64	64-bit value without sign
FLOATING_POINT	32-bit floating point number
VISIBLE_STRING	String of characters of printable characters
OCTET_STRING	String of characters of any characters
BITFIELD_8	8-bit value bit-coded
BITFIELD_16	16-bit value bit-coded
BITFIELD_32	32-bit value bit coded

#### 14.1.2 Parameters with read-only access

Parameters for which the "write access" attribute has not been set can only be read and not be changed by the user.

### Description structure

Parameter Name: <b>Cxxxxx</b>   _____	Data type: _____ Index: _____
Description	
<b>Display range (min. value   unit   max. value)</b>	
_____	
<input checked="" type="checkbox"/> Read access <input type="checkbox"/> Write access <input type="checkbox"/> CINH <input type="checkbox"/> PLC-STOP <input type="checkbox"/> No transfer	

### Representation in the »Engineer«

The »Engineer« displays these parameters with a grey background or, with an online connection, with a pale-yellow background:

	/ C...	/ S/	Name	Value	Unit
	61	0	Heatsink temperature	30	°C

### 14.1.3 Parameters with write access

Only parameters with a check mark (☑) in front of the "write access" attribute can be changed by the user. The Lenze setting for these parameters is **printed in bold**.

- The settings can either be selected from a selection list or the values can be entered directly.
- Values outside the valid setting range are represented in red in the »Engineer«.

# 14 Parameter reference

## 14.1 Structure of the parameter descriptions

### 14.1.3.1 Parameters with setting range

#### Description structure

Parameter   Name: Cxxxxx   _____	Data type: _____ Index: _____
Description	
<b>Setting range (min. value   unit   max. value)</b>	<b>Lenze setting</b>
<input checked="" type="checkbox"/> Read access <input checked="" type="checkbox"/> Write access <input type="checkbox"/> CINH <input type="checkbox"/> PLC-STOP <input type="checkbox"/> No transfer	

#### Parameter setting in the »Engineer«

In the »Engineer«, parameters are set by entering the desired value into the input field:

C...	S	Name	Value	Unit
22	0	Maximum current	0.00	A

### 14.1.3.2 Parameters with selection list

#### Description structure

Parameter   Name: Cxxxxx   _____	Data type: _____ Index: _____
Description	
<b>Selection list (Lenze setting printed in bold)</b>	
1	
2	
3	
<input checked="" type="checkbox"/> Read access <input checked="" type="checkbox"/> Write access <input type="checkbox"/> CINH <input type="checkbox"/> PLC-STOP <input type="checkbox"/> No transfer	

#### Parameter setting in the »Engineer«

In the »Engineer«, a list field is used for parameter setting:

C...	S	Name	Value	Unit
34	0	Config. analog input 1	0: -10 ... +10 V	

0: -10 ... +10 V  
1: -20...-4 mA, +4...+20 mA  
2: -20 ... +20 mA

# 14 Parameter reference

## 14.1 Structure of the parameter descriptions

### 14.1.3.3 Parameters with bit-coded setting

#### Description structure

Parameter   Name: <b>Cxxxxx</b>   _____	Data type: _____ Index: _____
Description	
<b>Value is bit-coded:</b>	
Bit 0	
...	
Bit 31	
<input checked="" type="checkbox"/> Read access <input checked="" type="checkbox"/> Write access <input type="checkbox"/> CINH <input type="checkbox"/> PLC-STOP <input type="checkbox"/> No transfer	

#### Parameter setting in the »Engineer«

The »Engineer« uses a dialog box for parameter setting in which the individual bits can be set or reset. Alternatively, the value can be entered as a decimal or hexadecimal value:

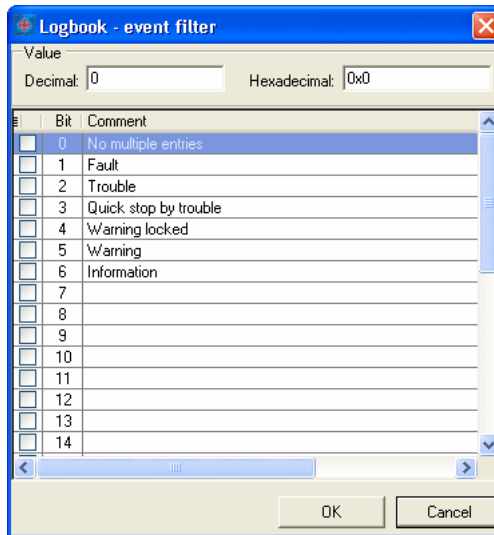



**14.1.3.4 Parameters with subcodes**

**Description structure**

Parameter   Name: <b>Cxxxxx</b>   _____		Data type: _____ Index: _____
Description		
<b>Setting range</b> (min. value   unit   max. value)		
<b>Subcodes</b>	<b>Lenze setting</b>	
Cxxxxx/1		
Cxxxxx/2		
Cxxxxx/3		
Cxxxxx/4		
<input checked="" type="checkbox"/> Read access <input checked="" type="checkbox"/> Write access <input type="checkbox"/> CINH <input type="checkbox"/> PLC-STOP <input type="checkbox"/> No transfer		

**Parameter setting in the »Engineer«**

The »Engineer« parameter list displays each subcode individually. The parameters are set as described in the previous chapters.

#	C...	S	Name	Value	Unit
	114	1	Dig. input. 1: Terminal polarity	0	
	114	2	Dig. input. 2: Terminal polarity	0	
	114	3	Dig. input. 3: Terminal polarity	0	
	114	4	Dig. input. 4: Terminal polarity	0	

#### 14.1.4 Parameter attributes

##### Description structure

The table footers contain the parameter attributes:

Read access    Write access    CINH    PLC-STOP    No transfer

##### Meaning of the attributes

Attribute	Meaning	
<input checked="" type="checkbox"/> Read access	Read access to parameter possible.	
<input checked="" type="checkbox"/> Write access	Write access to parameter possible. • Please also observe the following attributes:	
	<input checked="" type="checkbox"/> CINH	Parameter value can only be changed when the controller is inhibited.
	<input checked="" type="checkbox"/> PLC STOP	Parameter value can only be changed when the application is stopped.
<input checked="" type="checkbox"/> No transfer	The parameter is <b>not</b> transferred to the regenerative power supply module when the command <u>Download parameter set</u> is executed.	

##### Scaling factor

The "scaling factor" is important for the parameter access via a bus system:

$$\text{Read value (via bus system)} = \text{Scaling factor} \cdot \text{Indicated value (Engineer)}$$

#### 14.1.5 Abbreviations used in parameter & selection texts

Since the character length of the parameter and selection texts is limited, the following abbreviations are used:

Abbreviation	Meaning
CAN module	CANopen communication module (type E94AYCCA)
ENP	Electronic nameplate
Ethernet module	Ethernet communication module (type E94AYCEN)
MXI1	<i>Module eXtension Interface 1</i> - module slot for extension 1
MXI2	<i>Module eXtension Interface 2</i> - module slot for extension 2

### 14.2 Parameter list

This chapter lists all parameters of the operating system in numerically ascending order.



#### Note!

The parameter descriptions are based on the software version V15.00.xx.

#### C00002

Parameter   Name: <b>C00002   Device command</b>		Data type: UNSIGNED_32 Index: 24573 <sub>d</sub> = 5FFD <sub>h</sub>
Device commands <ul style="list-style-type: none"> <li>• <a href="#">C00003</a> shows the status of the last executed device command.</li> <li>• Under <a href="#">C00150</a> you can query the current status of the device control.</li> </ul>		
<b>Note:</b> Before switching off the supply voltage after a device command has been executed, check the successful execution of the device command via the status display in <a href="#">C00003</a> ! The meaning of the status display in <a href="#">C00003</a> can be obtained from the subchapter for the corresponding device command in chapter " <a href="#">Device commands</a> ".		
Selection list (Lenze setting printed in bold)		Info
0	<b>Load Lenze setting</b>	Resets parameters to Lenze setting. <ul style="list-style-type: none"> <li>• Only possible when the application has stopped and the controller is inhibited.</li> </ul>
1	Load start parameters	Loads parameters from the memory module. <ul style="list-style-type: none"> <li>• Only possible when the application has stopped and the controller is inhibited.</li> </ul>
2	ENP: Load plant data	Reads plant data from the electronic motor nameplate. <ul style="list-style-type: none"> <li>• Only possible when the application has stopped and the controller is inhibited.</li> </ul>
5	Activate application	Activates the application selected under <a href="#">C00005</a> . <ul style="list-style-type: none"> <li>• Whether the application is also started, depends on the auto-start setting selected.</li> <li>• Only possible when the application has stopped.</li> </ul>
7	Save selected application	Selects the active application as start application.
11	Save start parameters	Saves parameters fail-safe in the memory module.
20	Delete logbook	Deletes all logbook entries.
21	Archive logbook	Exports logbook entries to file.
27	Device search function ON	
28	Device search function OFF	
31	Start application	
32	Stop application	
33	Reset program	Carries out a reset. <ul style="list-style-type: none"> <li>• All variables are reset to their initialisation value.</li> <li>• The situation corresponds to the start of a new program loaded into the control (cold start).</li> </ul>
34	Delete program	Carries out a reset (source). <ul style="list-style-type: none"> <li>• All variables are reset to their initialisation value.</li> <li>• The application program is deleted and the controller is reset to its original state.</li> </ul>

Parameter   Name: <b>C00002   Device command</b>		Data type: UNSIGNED_32 Index: 24573 <sub>d</sub> = 5FFD <sub>h</sub>
35	Restart program	Carries out a reset (warm start). <ul style="list-style-type: none"> <li>All variables except the RETAIN variables are reset to their initialisation value.</li> <li>The situation corresponds to a power failure or switching the controller off/on (warm start) while the program is running.</li> </ul>
36	Reset runtime measurement	▶ <a href="#">Runtime measurement</a>
41	Inhibit inverter	
42	Enable inverter	
43	Error reset	
45	Activate quick stop	▶ Basic function " <a href="#">Quick stop</a> "
46	Reset quick stop	▶ Basic function " <a href="#">Quick stop</a> "
47	Internal command 47	For Lenze service only
48	Internal command 48	For Lenze service only
51	Identify pole position (360°)	Executes identification of pole position. <ul style="list-style-type: none"> <li>The function can only be activated when the controller is inhibited.</li> <li>After this, the execution of the command starts automatically when the controller is enabled.</li> <li>During the pole position identification, the motor carries out one electrical revolution. This leads to a mechanical rotation of the motor shaft.</li> <li>The determined pole position is indicated under code <a href="#">C00058</a>.</li> </ul> ▶ <a href="#">Pole position identification</a>
52	Identify pole position (min. motion)	Executes identification of pole position. <ul style="list-style-type: none"> <li>The function can only be activated when the controller is inhibited.</li> <li>After this, the execution of the command starts automatically when the controller is enabled.</li> <li>During the pole position identification, the rotor aligns itself. This is compensated by a position control.</li> <li>The determined pole position is indicated under code <a href="#">C00058</a>.</li> </ul> ▶ <a href="#">Pole position identification</a>
58	Internal command 58	<a href="#">From software version V15.0 onwards</a> For Lenze service only
59	Resolver error identification	<a href="#">From software version V7.0</a> Execute resolver error identification. ▶ <a href="#">Resolver error compensation</a>
70	Load Lenze inverter characteristic	<a href="#">From software version V4.0</a> Load type-dependent inverter error characteristic. <ul style="list-style-type: none"> <li>For the case that the determination of the inverter error characteristic with the device command "71: Determine inverter characteristic" was not possible or has supplied incorrect results.</li> <li>The function can only be activated when the controller is inhibited.</li> </ul>
71	Calculate inv. characteristic	Determines inverter error characteristic. <ul style="list-style-type: none"> <li>The function can only be activated when the controller is inhibited.</li> <li>After this, the execution of the command starts automatically when the controller is enabled.</li> </ul> ▶ <a href="#">Optimise the switching performance of the inverter</a>

Parameter   Name: <b>C00002   Device command</b>		Data type: UNSIGNED_32 Index: 24573 <sub>d</sub> = 5FFD <sub>h</sub>
72	Determine motor parameters	Determines motor parameters automatically. <ul style="list-style-type: none"> <li>The function can only be activated when the controller is inhibited.</li> <li>After this, the execution of the command starts automatically when the controller is enabled.</li> </ul> ▶ <a href="#">Determine motor parameters</a>
77	Calculate current controller parameters	<b>From software version V5.0</b> Calculates the gain and reset time of the current controller. <ul style="list-style-type: none"> <li>Usually not required for a Lenze motor.</li> <li>The device command is no identification procedure for determining the current controller parameters!</li> </ul> ▶ <a href="#">Calculate current controller parameters</a>
78	Calculate speed controller parameters	<b>From software version V5.0</b> Calculates the gain, reset, and rate time of the speed controller. <ul style="list-style-type: none"> <li>The device command is no identification procedure for determining the speed controller parameters!</li> </ul> ▶ <a href="#">Calculate speed controller parameters</a>
91	CAN on-board: Reset node	Reinitialise "CAN on board" interface. <ul style="list-style-type: none"> <li>Required when changing the baud rate, node address, or identifiers.</li> </ul> ▶ <a href="#">"CAN on board" system bus</a>
92	CAN module: Reset node	Reinitialises CANopen interface of the CANopen communication module. <ul style="list-style-type: none"> <li>Required when changing the baud rate, node address, or identifiers.</li> </ul>
93	CAN on-board: Pred.Connect.Set	Sets basic identifier for the "CAN on board" interface according to the "Predefined Connection Set" (DS301 V4.02). <ul style="list-style-type: none"> <li>▶ <a href="#">"CAN on board" system bus</a></li> </ul>
94	CAN module: Pred.Connect.Set	Sets basic identifier for the CANopen interface of the CANopen communication module according to the Predefined Connection Set" (DS301 V4.02).
95	CAN on-board: Identify node	Detects nodes connected to the "CAN on board" interface. <ul style="list-style-type: none"> <li>The result of the CAN bus scan is displayed in <a href="#">C00393</a>.</li> </ul> ▶ <a href="#">"CAN on board" system bus</a>
96	CAN module: Identify node	Detects the nodes connected to the CANopen interface of the CANopen communication module. <ul style="list-style-type: none"> <li>The result of the CAN bus scan is displayed in C13393 (for MX1) or C14393 (for MX2).</li> </ul>
101	Unbind/bind Ethernet module MX1	Reinitialises the Ethernet interface of the Ethernet communication module in module slot MX1. <ul style="list-style-type: none"> <li>Required when a new setting for an IP or gateway address is to be accepted without mains switching.</li> </ul>
102	Unbind/bind Ethernet module MX2	
201	Activate parameter set 1	Loads parameter set 1 from the memory module. <ul style="list-style-type: none"> <li>Only possible when the application has stopped and the controller is inhibited.</li> </ul>
202	Activate parameter set 2	Loads parameter set 2 from the memory module. <ul style="list-style-type: none"> <li>Only possible when the application has stopped and the controller is inhibited.</li> </ul>
203	Activate parameter set 3	Loads parameter set 3 from the memory module. <ul style="list-style-type: none"> <li>Only possible when the application has stopped and the controller is inhibited.</li> </ul>

Parameter   Name: <b>C00002   Device command</b>		Data type: UNSIGNED_32 Index: 24573 <sub>d</sub> = 5FFD <sub>h</sub>
204	Activate parameter set 4	Loads parameter set 4 from the memory module. • Only possible when the application has stopped and the controller is inhibited.
301	Archive parameter set 1	Saves the current parameter set as parameter set 1 in the memory module.
302	Archive parameter set 2	Saves the current parameter set as parameter set 2 in the memory module.
303	Archive parameter set 3	Saves the current parameter set as parameter set 3 in the memory module.
304	Archive parameter set 4	Saves the current parameter set as parameter set 4 in the memory module.
401	Internal command 401	For Lenze service only
501	Load cam data	<b>From software version V3.0</b> Reloads cam data from the memory module into the controller. • Only possible when the application has stopped and the controller is inhibited. • If the cam data are provided with an access protection, the user password has to be entered in <a href="#">C02900</a> first. ▶ Basic function " <a href="#">Cam data management</a> "
502	Save cam data	<b>From software version V3.0</b> Saves the cam data available in the main memory of the controller in the memory module with mains failure protection. • If the cam data are provided with an access protection, the user password has to be entered in <a href="#">C02900</a> first. ▶ Basic function " <a href="#">Cam data management</a> "
503	Calculate cam data	<b>From software version V3.0</b> Converts the cam data available in the main memory of the controller into the internal format and provides them to the application. ▶ Basic function " <a href="#">Cam data management</a> "
504	Calculate cam data checksum	<b>From software version V3.0</b> Recalculates the checksum of the cam data available in the main memory of the controller. • Required if the cam data in the main memory of the controller have been changed via parameters. ▶ Basic function " <a href="#">Cam data management</a> "
730	Internal command 730	For Lenze service only
731	Internal command 731	For Lenze service only
732	Internal command 732	For Lenze service only
733	Internal command 733	For Lenze service only
800	Internal command 800	For Lenze service only
810	Internal command 810	

Parameter   Name: <b>C00002   Device command</b>		Data type: UNSIGNED_32 Index: 24573 <sub>d</sub> = 5FFD <sub>h</sub>
811	Internal command 811	
812	Internal command 812	
1001	Internal command 1001	For Lenze service only
1020	Internal command 1020	For Lenze service only
1021	Export parameters to file	For Lenze service only
1030	Format file system	Formats file system of the memory module.
1040	Restore file system	Restores file system of the memory module (low level formatting). • The low level formatting of the file system by the user is only intended for the exceptional case when the standard formatting is not possible anymore, e.g. due to damaged internal management information.
10000	Prepare firmware update	Sets the controller to the firmware update mode.
11000	Restart controller	Restarts controller via parameter setting.
<input checked="" type="checkbox"/> Read access <input checked="" type="checkbox"/> Write access <input type="checkbox"/> CINH <input type="checkbox"/> PLC STOP <input checked="" type="checkbox"/> No transfer		Scaling factor: 1

**C00003**

Parameter   Name: <b>C00003   Device command status</b>		Data type: UNSIGNED_32 Index: 24572 <sub>d</sub> = 5FFC <sub>h</sub>
Display of the number/status of the device command last executed ( <a href="#">C00002</a> ). • The number of the command is situated in the upper 16 bits (for the meaning of the number see code <a href="#">C00002</a> ). • The result of the command stands in the lower 16 bits.		
<b>Note:</b>		
Before switching off the supply voltage after a device command has been executed, check the successful execution of the device command via the status display in <a href="#">C00003</a> ! The meaning of the status display in <a href="#">C00003</a> can be obtained from the subchapter for the corresponding device command in chapter " <a href="#">Device commands</a> ".		
Display range (min. value   unit   max. value)		
0		4294967295
<input checked="" type="checkbox"/> Read access <input type="checkbox"/> Write access <input type="checkbox"/> CINH <input type="checkbox"/> PLC STOP <input type="checkbox"/> No transfer		Scaling factor: 1

Status	Meaning	Device command
0	Device command executed successfully	0: <a href="#">Load Lenze setting</a>
1	General error	
34050	Device command in process	
39424	CAN fault	
...	...	
39679	CAN fault	
65536	Device command executed successfully	1: <a href="#">Load start parameters</a>
65537	General error	
99371	Fault while reading the parameter set partition	
99374	No memory module available	
99586	Device command in process	
104960	CAN fault	
...	...	
105215	CAN fault	

Status	Meaning	Device command
131072	Device command executed successfully	2: <a href="#">ETS: Load plant data</a>
131073	General error	
165122	Device command in process	
327680	Device command executed successfully	5: <a href="#">Activate application</a>
327681	General error	
361730	Device command in process	
458752	Device command executed successfully	7: <a href="#">Save selected application</a>
458753	General error	
492802	Device command in process	
720896	Device command executed successfully	11: <a href="#">Save start parameters</a>
720897	General error	
754718	Fault while writing into a file	
754734	No memory module available	
754946	Device command in process	
761857	Access to file has been denied since the file is already accessed from another position	
761861	I/O fault when accessing the file system	
761868	RAM is full	
761869	Access authorisation denied	
761884	No free memory on the memory module	
1310720	Device command executed successfully	20: <a href="#">Delete logbook</a>
1310721	General error	
1344770	Device command in process	
1376256	Device command executed successfully	21: <a href="#">Archive logbook</a>
1376257	General error	
1410306	Device command in process	
2031616	Device command executed successfully	31: <a href="#">Start application</a>
2031617	General error	
2065666	Device command in process	
2097152	Device command executed successfully	32: <a href="#">Stop application</a>
2097153	General error	
2131202	Device command in process	
2162688	Device command executed successfully	33: <a href="#">Reset program</a>
2162689	General error	
2196738	Device command in process	
2228224	Device command executed successfully	34: <a href="#">Delete program</a>
2228225	General error	
2262274	Device command in process	
2293760	Device command executed successfully	35: <a href="#">Restart program</a>
2293761	General error	
2327810	Device command in process	
2359296	Device command executed successfully	36: <a href="#">Reset runtime measurement</a>
2359297	General error	
2393346	Device command in process	



Status	Meaning	Device command	
3342336	Device command executed successfully	51: <a href="#">Identify pole position (360°)</a>	
3342337	General error		
3376386	Device command in process		
3382023	Pole position identification cannot be executed because of wrong motor type (asynchronous motor).		
3382024	Pole position identification has been aborted		
3382025	Pole position identification cannot be executed because another identification is already active.		
3382026	Identification of pole position cannot be executed because U-rotation or I-rotation test mode is active.		
3382027	Identification of pole position cannot be executed because current controller optimisation mode is active.		
3382033	Pole position identification cannot be executed because the motor is blocked (e.g. by a mechanical brake), a motor phase is not connected, or a phase shifter is in the motor cable.		
3382047	Pole position identification cannot be executed because an error or trouble is active.		
3382065 <small>From software version V3.0</small>	Pole position identification cannot be executed because either the entire motor or a motor phase is not connected.		
3407872	Device command executed successfully		52: <a href="#">Identify pole position (min. motion)</a>
3407873	General error		
3441922	Device command in process		
3447559	Pole position identification cannot be executed because of wrong motor type (asynchronous motor).		
3447560	Pole position identification has been aborted		
3447561	Pole position identification cannot be executed because another identification is already active.		
3447562	Identification of pole position cannot be executed because U-rotation or I-rotation test mode is active.		
3447563	Identification of pole position cannot be executed because current controller optimisation mode is active.		
3447569 <small>From software version V4.0</small>	Pole position identification cannot be executed because the motor is blocked (e.g. by a mechanical brake), a motor phase is not connected, or a phase shifter is in the motor cable.		
3447583	Pole position identification cannot be executed because an error or trouble is active.		
3447597	Identification of pole position cannot be executed because the rotor has moved too strongly.		
3447601 <small>From software version V3.0</small>	Pole position identification cannot be executed because either the entire motor or a motor phase is not connected.		

Status	Meaning	Device command
3900674	Device command in process	59: <a href="#">Resolver error identification</a>
3866624	Device command executed successfully	
3866625	General error	
3906358	Resolver error identification cannot be executed since the wrong control type is active (no servo control).	
3906359	Resolver error identification cannot be executed since an error or trouble is active.	
3906360	Resolver error identification cannot be executed because another identification is already active.	
3906361	Resolver error identification cannot be executed because of too small speed (< 500 rpm).	
4587520	Device command executed successfully	70: <a href="#">Load Lenze INV characteristic</a>
4587521	General error	
4621570	Device command in process	
4653056	Device command executed successfully	71: <a href="#">Calculate inv. characteristic</a>
4653057	General error	
4687106	Device command in process	
4692754	The calculation of the inverter characteristic cannot be started since the current controller test mode is active.	
4692755	The calculation of the inverter characteristic cannot be started since the V/f test mode is active.	
4692756	The calculation of the inverter characteristic cannot be started since the pole position identification is active.	
4692757	Calculation of the inverter characteristic has been aborted.	
4692758	Calculation of the inverter characteristic has been interrupted by error.	
4692789 <small>From software version V5.0</small>	Detected inverter error characteristic exceeds internal limits. This situation can for instance occur if the motor power is very much lower than the device power.	72: <a href="#">Determine motor parameters</a>
4718592	Device command executed successfully	
4718593	General error	
4752642	Device command in process	
4758290	Motor identification cannot be started since the current controller test mode is active.	
4758291	Motor identification cannot be started since the V/f test mode is active.	
4758292	Motor identification cannot be started because pole position identification is active.	
4758293	Motor identification has been aborted.	
4758294	Motor identification has been aborted by fault.	
4758332 <small>From software version V7.0</small>	Motor identification aborted due to inconsistent motor parameters.	
5046272	Device command executed successfully	77: <a href="#">Calculate current controller parameters</a>
5046273	General error	
5080322	Device command in process	
5086002	At least one calculated value is outside the valid setting range.	
5086003	Stator resistance ( <a href="#">C00084</a> ) too small (zero).	

Status	Meaning	Device command
5111808	Device command executed successfully	78: <a href="#">Calculate speed controller parameters</a>
5111809	General error	
5145858	Device command in process	
5151540	At least one calculated value is outside the valid setting range.	91: <a href="#">CAN on board: Reset Node</a>
5963776	Device command executed successfully	
5963777	General error	
5997826	Device command in process	
6003200	CAN fault	
...	...	
6003455	CAN fault	
6029312	Device command executed successfully	92: <a href="#">CAN module: Reset node</a>
6029313	General error	
6063362	Device command in process	
6068736	CAN fault	
...	...	
6068991	CAN fault	93: <a href="#">CAN on board: Pred.Connect.Set</a>
6094848	Device command executed successfully	
6094849	General error	
6128898	Device command in process	94: <a href="#">CAN module: Pred.Connect.Set</a>
6160384	Device command executed successfully	
6160385	General error	
6194434	Device command in process	
6225920	Device command executed successfully	95: <a href="#">CAN on board: Identify node</a>
6225921	General error	
6259970	Device command in process	
6291456	Device command executed successfully	96: <a href="#">CAN module: Identify node</a>
6291457	General error	
6325506	Device command in process	
6619136	Device command executed successfully	101: <a href="#">Unbind/bind Ethernet module MXI1</a>
6619137	General error	
6653186	Device command in process	102: <a href="#">Unbind/bind Ethernet module MXI2</a>
6684672	Device command executed successfully	
6684673	General error	
6718722	Device command in process	

Status	Meaning	Device command
13172731	General error	201: <a href="#">Activate parameter set 1</a>
13172736	Device command executed successfully	
13206532	File could not be opened.	
13206557	Fault while reading out of a file.	
13206558	Fault while writing into a file.	
13206559	Invalid file type.	
13206560	Unexpected end of file.	
13206562	Checksum error	
13206786	Device command in process	
13212160	CAN fault	
...	...	
13212415	CAN fault	
13213697	Access to file has been denied since the file is already accessed from another position	
13213701	I/O fault when accessing the file system	
13213708	RAM is full	
13213709	Access authorisation denied	
13213724	No free memory on the memory module	
13238272	Device command executed successfully	202: <a href="#">Activate parameter set 2</a>
13238273	General error	
13272068	File could not be opened.	
13272093	Fault while reading out of a file.	
13272094	Fault while writing into a file.	
13272095	Invalid file type.	
13272096	Unexpected end of file.	
13272098	Checksum error	
13272322	Device command in process	
13277696	CAN fault	
...	...	
13277951	CAN fault	
13279233	Access to file has been denied since the file is already accessed from another position	
13279237	I/O fault when accessing the file system	
13279244	RAM is full	
13279245	Access authorisation denied	
13279260	No free memory on the memory module	

Status	Meaning	Device command
13303808	Device command executed successfully	203: <a href="#">Activate parameter set 3</a>
13303809	General error	
13337604	File could not be opened.	
13337629	Fault while reading out of a file.	
13337630	Fault while writing into a file.	
13337631	Invalid file type.	
13337632	Unexpected end of file.	
13337634	Checksum error	
13337858	Device command in process	
13343232	CAN fault	
...	...	
13343487	CAN fault	
13344769	Access to file has been denied since the file is already accessed from another position	
13344773	I/O fault when accessing the file system	
13344780	RAM is full	
13344781	Access authorisation denied	
13344796	No free memory on the memory module	
13369344	Device command executed successfully	204: <a href="#">Activate parameter set 4</a>
13369345	General error	
13403140	File could not be opened.	
13403165	Fault while reading out of a file.	
13403166	Fault while writing into a file.	
13403167	Invalid file type.	
13403168	Unexpected end of file.	
13403170	Checksum error	
13403394	Device command in process	
13408768	CAN fault	
...	...	
13409023	CAN fault	
13410305	Access to file has been denied since the file is already accessed from another position	
13410309	I/O fault when accessing the file system	
13410316	RAM is full	
13410317	Access authorisation denied	
13410332	No free memory on the memory module	

Status	Meaning	Device command
19726336	Device command executed successfully	301: <a href="#">Archive parameter set 1</a>
19726337	General error	
19760132	File could not be opened.	
19760157	Fault while reading out of a file.	
19760158	Fault while writing into a file.	
19760160	Unexpected end of file.	
19760386	Device command in process	
19767297	Access to file has been denied since the file is already accessed from another position	
19767301	I/O fault when accessing the file system	
19767308	RAM is full	
19767309	Access authorisation denied	
19767324	No free memory on the memory module	
19791872	Device command executed successfully	
19791873	General error	
19825668	File could not be opened.	
19825693	Fault while reading out of a file.	
19825694	Fault while writing into a file.	
19825696	Unexpected end of file.	
19825922	Device command in process	
19832833	Access to file has been denied since the file is already accessed from another position	
19832837	I/O fault when accessing the file system	
19832844	RAM is full	
19832845	Access authorisation denied	
19832860	No free memory on the memory module	
19857408	Device command executed successfully	303: <a href="#">Archive parameter set 3</a>
19857409	General error	
19891204	File could not be opened.	
19891229	Fault while reading out of a file.	
19891230	Fault while writing into a file.	
19891232	Unexpected end of file.	
19891458	Device command in process	
19898369	Access to file has been denied since the file is already accessed from another position	
19898373	I/O fault when accessing the file system	
19898380	RAM is full	
19898381	Access authorisation denied	
19898396	No free memory on the memory module	

Status	Meaning	Device command	
19922944	Device command executed successfully	304: <a href="#">Archive parameter set 4</a>	
19922945	General error		
19956740	File could not be opened.		
19956765	Fault while reading out of a file.		
19956766	Fault while writing into a file.		
19956768	Unexpected end of file.		
19956994	Device command in process		
19963905	Access to file has been denied since the file is already accessed from another position		
19963909	I/O fault when accessing the file system		
19963916	RAM is full		
19963917	Access authorisation denied		
19963932	No free memory on the memory module		
32833536	Device command executed successfully		501: <a href="#">Load cam data</a>
32833537	General error		
32867586	Device command in process		
32875521	No cam data available on the memory module		
32875523	Loading of the cam data failed		
32875525	Checksum error		
32875542	Wrong password entered		
32875545	The cam functionality is deactivated		
32899072	Device command executed successfully	502: <a href="#">Save cam data</a>	
32899073	General error		
32933122	Device command in process		
32941057	No cam data to be saved are available in the RAM of the controller		
32941060	Saving of the cam data failed		
32941078	Wrong password entered		
32941081	The cam functionality is deactivated		
32964608	Device command executed successfully	503: <a href="#">Calculate cam data</a>	
32964609	General error		
32998658	Device command in process		
33006617	The cam functionality is deactivated		
33030144	Device command executed successfully	504: <a href="#">Calculate cam data checksum</a>	
33030145	General error		
33064194	Device command in process		
33072153	The cam functionality is deactivated		
67502080	Device command executed successfully	1030: <a href="#">Format file system</a>	
67502081	General error		
67536130	Device command in process		
655360000	Device command executed successfully	10000: <a href="#">Prepare firmware update</a>	
655360001	General error		
655394050	Device command in process		
720896001	General error	11000: <a href="#">Restart controller</a>	
720930050	Device command in process		

## C00004

Parameter   Name: <b>C00004   Service password</b>		Data type: UNSIGNED_32 Index: 24571 <sub>d</sub> = 5FFB <sub>h</sub>
Service code to unlock protected device commands ( <a href="#">C00002</a> ).		
<b>Setting range</b> (min. value   unit   max. value)		<b>Lenze setting</b>
0		4294967295 <b>0</b>
<input checked="" type="checkbox"/> Read access <input checked="" type="checkbox"/> Write access <input type="checkbox"/> CINH <input type="checkbox"/> PLC STOP <input checked="" type="checkbox"/> No transfer		Scaling factor: 1

## C00005

Parameter   Name: <b>C00005   Application selection</b>		Data type: INTEGER_32 Index: 24570 <sub>d</sub> = 5FFA <sub>h</sub>
Application selection <ul style="list-style-type: none"> <li>• Use the device command <a href="#">C00002</a>="5" to activate the selected application.</li> </ul>		
Note regarding the setting values: <ul style="list-style-type: none"> <li>• -1: No response</li> <li>• 0: For Lenze service only</li> <li>• 1: Active application (after download via the Engineer)</li> <li>• 2 ... 16: Application spots cannot be used</li> </ul>		
<b>Setting range</b> (min. value   unit   max. value)		<b>Lenze setting</b>
-1		16 <b>0</b>
<input checked="" type="checkbox"/> Read access <input checked="" type="checkbox"/> Write access <input type="checkbox"/> CINH <input type="checkbox"/> PLC STOP <input checked="" type="checkbox"/> No transfer		Scaling factor: 1

## C00006

Parameter   Name: <b>C00006   Select motor control</b>		Data type: UNSIGNED_32 Index: 24569 <sub>d</sub> = 5FF9 <sub>h</sub>
▶ <a href="#">Motor interface</a>		
<b>Selection list</b> (Lenze setting printed in bold)		<b>Info</b>
1	<b>SC: Servo control sync. motor</b>	For synchronous motors with speed sensor ▶ <a href="#">Servo control</a>
2	SC: Servo control async. motor	For asynchronous motors with speed sensor ▶ <a href="#">Servo control</a>
4	SLVC: sensorless vector control	From software version V3.0 ▶ <a href="#">Sensorless vector control</a>
6	VFCplus: V/f control open loop	From software version V3.0 ▶ <a href="#">V/f control</a>
7	VFCplus: V/f control closed loop	From software version V3.0 ▶ <a href="#">V/f control</a>
<input checked="" type="checkbox"/> Read access <input checked="" type="checkbox"/> Write access <input checked="" type="checkbox"/> CINH <input type="checkbox"/> PLC STOP <input type="checkbox"/> No transfer		Scaling factor: 1

## C00007

Parameter   Name: <b>C00007   Active application</b>		Data type: INTEGER_32 Index: 24568 <sub>d</sub> = 5FF8 <sub>h</sub>
<b>Display range</b> (min. value   unit   max. value)		
-2147483648		2147483647
<input checked="" type="checkbox"/> Read access <input type="checkbox"/> Write access <input type="checkbox"/> CINH <input type="checkbox"/> PLC STOP <input type="checkbox"/> No transfer		Scaling factor: 1



## C00008

Parameter   Name: <b>C00008   Progress of device command</b>		Data type: UNSIGNED_32 Index: 24567 <sub>d</sub> = 5FF7 <sub>h</sub>
From software version V7.0		
Display range (min. value   unit   max. value)		
0		4294967295
<input checked="" type="checkbox"/> Read access <input type="checkbox"/> Write access <input type="checkbox"/> CINH <input type="checkbox"/> PLC STOP <input type="checkbox"/> No transfer		Scaling factor: 1

## C00011

Parameter   Name: <b>C00011   Motor reference speed</b>		Data type: UNSIGNED_32 Index: 24564 <sub>d</sub> = 5FF4 <sub>h</sub>
For parameter setting via interface: In case of bigger changes, only change the setting in one step when the controller is inhibited!		
Setting range (min. value   unit   max. value)		Lenze setting
50	rpm	50000 <b>3000 rpm</b>
<input checked="" type="checkbox"/> Read access <input checked="" type="checkbox"/> Write access <input type="checkbox"/> CINH <input type="checkbox"/> PLC STOP <input type="checkbox"/> No transfer		Scaling factor: 1

## C00018

Parameter   Name: <b>C00018   Switching frequency</b>		Data type: UNSIGNED_32 Index: 24557 <sub>d</sub> = 5FED <sub>h</sub>
Selection list (Lenze setting printed in bold)		Info
2	1 kHz fixed/drive-optimised	<b>Note:</b> <ul style="list-style-type: none"> <li>The maximum output frequency of the controller is limited to 1/8 of the switching frequency selected here!</li> <li>The switching frequencies that can be selected depend on the device type (see Hardware Manual, chapter "Rated data").</li> <li>In the case of an offline parameter setting or when exchanging the memory module between different Servo Drives 9400 HighLine device types, always check the setting of this parameter and adapt it, if required, to prevent a parameter error after the parameter set download or module change!</li> </ul>
3	2 kHz fixed/drive-optimised	
4	4 kHz fixed/drive-optimised	
5	8 kHz fixed/drive-optimised	
8	2 kHz var./drive-optimised	
9	4 kHz var./drive-optimised	
<b>10</b>	<b>8 kHz var./drive-optimised</b>	
11	16 kHz var./drive-optimised	
<input checked="" type="checkbox"/> Read access <input checked="" type="checkbox"/> Write access <input type="checkbox"/> CINH <input type="checkbox"/> PLC STOP <input type="checkbox"/> No transfer		Scaling factor: 1

## C00019

Parameter   Name: <b>C00019   Threshold - standstill recognition</b>		Data type: UNSIGNED_32 Index: 24556 <sub>d</sub> = 5FEC <sub>h</sub>
Setting range (min. value   unit   max. value)		Lenze setting
0	rpm	450 <b>5 rpm</b>
<input checked="" type="checkbox"/> Read access <input checked="" type="checkbox"/> Write access <input type="checkbox"/> CINH <input type="checkbox"/> PLC STOP <input type="checkbox"/> No transfer		Scaling factor: 1

## C00022

Parameter   Name: <b>C00022   Maximum current</b>			Data type: UNSIGNED_32 Index: 24553 <sub>d</sub> = 5FE9 <sub>h</sub>
<b>Note:</b>			
<ul style="list-style-type: none"> <li>To avoid that the motor starts unintentionally without adjusting the plant data, the maximum current in the Lenze setting is set to "0 A"!</li> <li>The upper limit value is the maximum device current (see display in <a href="#">C00789</a>).</li> <li>In the case of an offline parameter setting or when exchanging the memory module between different 9400 HighLine device types, always check the setting of this parameter and adapt it, if required, to prevent a parameter error after the parameter set download or module change!</li> <li>Also check the threshold set for the maximum motor current monitoring (<a href="#">C00620</a>).</li> </ul>			
<b>Setting range (min. value   unit   max. value)</b>			<b>Lenze setting</b>
0.00	A	21474836.47	<b>0.00 A</b>
<input checked="" type="checkbox"/> Read access <input checked="" type="checkbox"/> Write access <input type="checkbox"/> CINH <input type="checkbox"/> PLC STOP <input type="checkbox"/> No transfer			Scaling factor: 100

## C00034

Parameter   Name: <b>C00034   Config. analog input 1</b>			Data type: UNSIGNED_32 Index: 24541 <sub>d</sub> = 5FDD <sub>h</sub>
<b>Selection list (Lenze setting printed in bold)</b>			
<b>0</b>	<b>-10...+10 V</b>		
1	-20...-4 mA, +4...+20 mA		
2	-20 ... +20 mA		
<input checked="" type="checkbox"/> Read access <input checked="" type="checkbox"/> Write access <input type="checkbox"/> CINH <input type="checkbox"/> PLC STOP <input type="checkbox"/> No transfer			Scaling factor: 1

## C00050

Parameter   Name: <b>C00050   Speed setpoint [rpm]</b>			Data type: INTEGER_32 Index: 24525 <sub>d</sub> = 5FCD <sub>h</sub>
<b>Display range (min. value   unit   max. value)</b>			
-480000	rpm	480000	
<b>Subcodes</b>			<b>Info</b>
C00050/1			Speed setpoint 1 [rpm]
C00050/2			Speed setpoint 2 [rpm]
<input checked="" type="checkbox"/> Read access <input type="checkbox"/> Write access <input type="checkbox"/> CINH <input type="checkbox"/> PLC STOP <input type="checkbox"/> No transfer			Scaling factor: 1

## C00051

Parameter   Name: <b>C00051   Actual speed [rpm]</b>			Data type: INTEGER_32 Index: 24524 <sub>d</sub> = 5FCC <sub>h</sub>
<b>Display range (min. value   unit   max. value)</b>			
-480000	rpm	480000	
<input checked="" type="checkbox"/> Read access <input type="checkbox"/> Write access <input type="checkbox"/> CINH <input type="checkbox"/> PLC STOP <input type="checkbox"/> No transfer			Scaling factor: 1

## C00052

Parameter   Name: <b>C00052   Motor voltage</b>			Data type: UNSIGNED_32 Index: 24523 <sub>d</sub> = 5FCB <sub>h</sub>
<b>Display range (min. value   unit   max. value)</b>			
0	V	2147483647	
<input checked="" type="checkbox"/> Read access <input type="checkbox"/> Write access <input type="checkbox"/> CINH <input type="checkbox"/> PLC STOP <input type="checkbox"/> No transfer			Scaling factor: 1

## C00053

Parameter   Name: <b>C00053   DC-bus voltage</b>		Data type: UNSIGNED_32 Index: 24522 <sub>d</sub> = 5FC <sub>Ah</sub>
<b>Display range (min. value   unit   max. value)</b>		
0	V	2147483647
<input checked="" type="checkbox"/> Read access <input type="checkbox"/> Write access <input type="checkbox"/> CINH <input type="checkbox"/> PLC STOP <input type="checkbox"/> No transfer		Scaling factor: 1

## C00054

Parameter   Name: <b>C00054   Motor current</b>		Data type: UNSIGNED_32 Index: 24521 <sub>d</sub> = 5FC <sub>9h</sub>
<b>Display range (min. value   unit   max. value)</b>		
0.00	A	500.00
<input checked="" type="checkbox"/> Read access <input type="checkbox"/> Write access <input type="checkbox"/> CINH <input type="checkbox"/> PLC STOP <input type="checkbox"/> No transfer		Scaling factor: 100

## C00055

Parameter   Name: <b>C00055   Phase currents</b>		Data type: INTEGER_32 Index: 24520 <sub>d</sub> = 5FC <sub>8h</sub>
<b>Display range (min. value   unit   max. value)</b>		
-500.00	A	500.00
<b>Subcodes</b>		<b>Info</b>
C00055/1		Phase zero system
C00055/2		Phase U
C00055/3		Phase V
C00055/4		Phase W
<input checked="" type="checkbox"/> Read access <input type="checkbox"/> Write access <input type="checkbox"/> CINH <input type="checkbox"/> PLC STOP <input type="checkbox"/> No transfer		Scaling factor: 100

## C00056

Parameter   Name: <b>C00056   Torque setpoint</b>		Data type: INTEGER_32 Index: 24519 <sub>d</sub> = 5FC <sub>7h</sub>
<b>Display range (min. value   unit   max. value)</b>		
-21474836.47	Nm	21474836.47
<input checked="" type="checkbox"/> Read access <input type="checkbox"/> Write access <input type="checkbox"/> CINH <input type="checkbox"/> PLC STOP <input type="checkbox"/> No transfer		Scaling factor: 100

## C00057

Parameter   Name: <b>C00057   Torque</b>		Data type: UNSIGNED_32 Index: 24518 <sub>d</sub> = 5FC <sub>6h</sub>
<b>Display range (min. value   unit   max. value)</b>		
0.000	Nm	2147483.647
<b>Subcodes</b>		<b>Info</b>
C00057/1		Maximum torque • With regard to the selected motor and the max. short-time output current of the device.
C00057/2		Motor reference torque • Torque at maximum current ( <a href="#">C00022</a> ).
<input checked="" type="checkbox"/> Read access <input type="checkbox"/> Write access <input type="checkbox"/> CINH <input type="checkbox"/> PLC STOP <input type="checkbox"/> No transfer		Scaling factor: 1000

## C00058

Parameter   Name: <b>C00058   Pole position</b>		Data type: INTEGER_32 Index: 24517 <sub>d</sub> = 5FC5 <sub>h</sub>
<b>Setting range (min. value   unit   max. value)</b>		
-179.9	°	179.9
<b>Subcodes</b>	<b>Lenze setting</b>	<b>Info</b>
C00058/1	-90.0 °	Resolver pole position
C00058/2	0.0 °	Encoder pole position
C00058/3	0.0 °	Module pole position
<input checked="" type="checkbox"/> Read access <input checked="" type="checkbox"/> Write access <input type="checkbox"/> CINH <input type="checkbox"/> PLC STOP <input type="checkbox"/> No transfer		Scaling factor: 10

## C00059

Parameter   Name: <b>C00059   Motor - number of pole pairs</b>		Data type: UNSIGNED_32 Index: 24516 <sub>d</sub> = 5FC4 <sub>h</sub>
<b>Display range (min. value   unit   max. value)</b>		
0		200
<input checked="" type="checkbox"/> Read access <input type="checkbox"/> Write access <input type="checkbox"/> CINH <input type="checkbox"/> PLC STOP <input type="checkbox"/> No transfer		Scaling factor: 1

## C00060

Parameter   Name: <b>C00060   Rotor position</b>		Data type: INTEGER_32 Index: 24515 <sub>d</sub> = 5FC3 <sub>h</sub>
<b>Display range (min. value   unit   max. value)</b>		
0		2047
<input checked="" type="checkbox"/> Read access <input type="checkbox"/> Write access <input type="checkbox"/> CINH <input type="checkbox"/> PLC STOP <input type="checkbox"/> No transfer		Scaling factor: 1

## C00061

Parameter   Name: <b>C00061   Heatsink temperature</b>		Data type: INTEGER_32 Index: 24514 <sub>d</sub> = 5FC2 <sub>h</sub>
<b>Display range (min. value   unit   max. value)</b>		
-200	°C	200
<input checked="" type="checkbox"/> Read access <input type="checkbox"/> Write access <input type="checkbox"/> CINH <input type="checkbox"/> PLC STOP <input type="checkbox"/> No transfer		Scaling factor: 1

## C00062

Parameter   Name: <b>C00062   Temperature inside the controller</b>		Data type: INTEGER_32 Index: 24513 <sub>d</sub> = 5FC1 <sub>h</sub>
<b>Display range (min. value   unit   max. value)</b>		
-200	°C	200
<input checked="" type="checkbox"/> Read access <input type="checkbox"/> Write access <input type="checkbox"/> CINH <input type="checkbox"/> PLC STOP <input type="checkbox"/> No transfer		Scaling factor: 1

## C00063

Parameter   Name: <b>C00063   Motor temperature</b>		Data type: INTEGER_32 Index: 24512 <sub>d</sub> = 5FC0 <sub>h</sub>
<a href="#">▶ Motor temperature monitoring</a>		
<b>Display range (min. value   unit   max. value)</b>		
-200	°C	200
<input checked="" type="checkbox"/> Read access <input type="checkbox"/> Write access <input type="checkbox"/> CINH <input type="checkbox"/> PLC STOP <input type="checkbox"/> No transfer		Scaling factor: 1

## C00064

Parameter   Name: <b>C00064   Device utilisation (Ixt)</b>		Data type: UNSIGNED_32 Index: 24511 <sub>d</sub> = 5FBF <sub>h</sub>	
Device utilisation during the last 180 seconds <ul style="list-style-type: none"> <li>• C00064 &gt; 100 % activates error (OC5).</li> <li>• Error reset only possible if C00064 &lt; 95 %.</li> </ul>			
<b>Display range (min. value   unit   max. value)</b>			
0	%	250	
<input checked="" type="checkbox"/> Read access		<input type="checkbox"/> Write access <input type="checkbox"/> CINH <input type="checkbox"/> PLC STOP <input type="checkbox"/> No transfer	
Scaling factor: 1			

## C00065

Parameter   Name: <b>C00065   Ext. 24-V voltage</b>		Data type: INTEGER_32 Index: 24510 <sub>d</sub> = 5FBE <sub>h</sub>	
<b>Display range (min. value   unit   max. value)</b>			
0.0	V	1000.0	
<input checked="" type="checkbox"/> Read access		<input type="checkbox"/> Write access <input type="checkbox"/> CINH <input type="checkbox"/> PLC STOP <input type="checkbox"/> No transfer	
Scaling factor: 10			

## C00066

Parameter   Name: <b>C00066   Thermal motor load (I<sup>2</sup>xt)</b>		Data type: UNSIGNED_32 Index: 24509 <sub>d</sub> = 5FBD <sub>h</sub>	
A 100 % load corresponds to a permanently flowing rated motor current			
<a href="#">▶ I<sup>2</sup>xt motor monitoring</a>			
<b>Display range (min. value   unit   max. value)</b>			
0	%	250	
<input checked="" type="checkbox"/> Read access		<input type="checkbox"/> Write access <input type="checkbox"/> CINH <input type="checkbox"/> PLC STOP <input type="checkbox"/> No transfer	
Scaling factor: 1			

## C00068

Parameter   Name: <b>C00068   Capacitor temperature</b>		Data type: INTEGER_32 Index: 24507 <sub>d</sub> = 5FBB <sub>h</sub>	
<b>Display range (min. value   unit   max. value)</b>			
-200	°C	200	
<input checked="" type="checkbox"/> Read access		<input type="checkbox"/> Write access <input type="checkbox"/> CINH <input type="checkbox"/> PLC STOP <input type="checkbox"/> No transfer	
Scaling factor: 1			

## C00069

Parameter   Name: <b>C00069   CPU temperature</b>		Data type: INTEGER_32 Index: 24506 <sub>d</sub> = 5FBA <sub>h</sub>	
<b>Display range (min. value   unit   max. value)</b>			
-200	°C	200	
<input checked="" type="checkbox"/> Read access		<input type="checkbox"/> Write access <input type="checkbox"/> CINH <input type="checkbox"/> PLC STOP <input type="checkbox"/> No transfer	
Scaling factor: 1			

## C00070

Parameter   Name: <b>C00070   Speed controller gain</b>		Data type: UNSIGNED_32 Index: 24505 <sub>d</sub> = 5FB9 <sub>h</sub>	
<b>Setting range (min. value   unit   max. value)</b>		<b>Lenze setting</b>	
0.00000	Nm/rpm	20000.00000	<b>0.00044 Nm/rpm</b>
<input checked="" type="checkbox"/> Read access		<input checked="" type="checkbox"/> Write access <input type="checkbox"/> CINH <input type="checkbox"/> PLC STOP <input type="checkbox"/> No transfer	
Scaling factor: 100000			

## C00071

Parameter   Name: <b>C00071   Speed contr. reset time</b>			Data type: UNSIGNED_32 Index: 24504 <sub>d</sub> = 5FB8 <sub>h</sub>
Setting range (min. value   unit   max. value)			Lenze setting
1.0	ms	6000.0	<b>14.4 ms</b>
<input checked="" type="checkbox"/> Read access <input checked="" type="checkbox"/> Write access <input type="checkbox"/> CINH <input type="checkbox"/> PLC STOP <input type="checkbox"/> No transfer			Scaling factor: 10

## C00072

Parameter   Name: <b>C00072   Speed contr.D component</b>			Data type: UNSIGNED_32 Index: 24503 <sub>d</sub> = 5FB7 <sub>h</sub>
Setting range (min. value   unit   max. value)			Lenze setting
0.00	ms	3.00	<b>0.00 ms</b>
<input checked="" type="checkbox"/> Read access <input checked="" type="checkbox"/> Write access <input type="checkbox"/> CINH <input type="checkbox"/> PLC STOP <input type="checkbox"/> No transfer			Scaling factor: 100

## C00074

Parameter   Name: <b>C00074   Feedfwd. ctrl. - current contr.</b>			Data type: UNSIGNED_8 Index: 24501 <sub>d</sub> = 5FB5 <sub>h</sub>
Selection list (Lenze setting printed in bold)			
0	Deactivate feedfwd. ctrl		
1	Activate feedfwd. ctrl		
<input checked="" type="checkbox"/> Read access <input checked="" type="checkbox"/> Write access <input type="checkbox"/> CINH <input type="checkbox"/> PLC STOP <input type="checkbox"/> No transfer			Scaling factor: 1

## C00075

Parameter   Name: <b>C00075   Current controller gain</b>			Data type: UNSIGNED_32 Index: 24500 <sub>d</sub> = 5FB4 <sub>h</sub>
Setting range (min. value   unit   max. value)			Lenze setting
0.00	V/A	750.00	<b>105.00 V/A</b>
<input checked="" type="checkbox"/> Read access <input checked="" type="checkbox"/> Write access <input type="checkbox"/> CINH <input type="checkbox"/> PLC STOP <input type="checkbox"/> No transfer			Scaling factor: 100

## C00076

Parameter   Name: <b>C00076   Current contr. reset time</b>			Data type: UNSIGNED_32 Index: 24499 <sub>d</sub> = 5FB3 <sub>h</sub>
Setting range (min. value   unit   max. value)			Lenze setting
0.01	ms	2000.00	<b>2.00 ms</b>
<input checked="" type="checkbox"/> Read access <input checked="" type="checkbox"/> Write access <input type="checkbox"/> CINH <input type="checkbox"/> PLC STOP <input type="checkbox"/> No transfer			Scaling factor: 100

## C00077

Parameter   Name: <b>C00077   Field controller gain</b>			Data type: UNSIGNED_32 Index: 24498 <sub>d</sub> = 5FB2 <sub>h</sub>
Setting range (min. value   unit   max. value)			Lenze setting
0.00	A/Vs	50000.00	<b>165.84 A/Vs</b>
<input checked="" type="checkbox"/> Read access <input checked="" type="checkbox"/> Write access <input type="checkbox"/> CINH <input type="checkbox"/> PLC STOP <input type="checkbox"/> No transfer			Scaling factor: 100

## C00078

Parameter   Name: <b>C00078   Field contr. reset time</b>			Data type: UNSIGNED_32 Index: 24497 <sub>d</sub> = 5FB1 <sub>h</sub>
<b>Setting range (min. value   unit   max. value)</b>			<b>Lenze setting</b>
1.0	ms	6000.0	<b>15.1 ms</b>
<input checked="" type="checkbox"/> Read access <input checked="" type="checkbox"/> Write access <input type="checkbox"/> CINH <input type="checkbox"/> PLC STOP <input type="checkbox"/> No transfer			Scaling factor: 10

## C00079

Parameter   Name: <b>C00079   Motor - mutual inductance</b>			Data type: UNSIGNED_32 Index: 24496 <sub>d</sub> = 5FB0 <sub>h</sub>
<b>Display range (min. value   unit   max. value)</b>			
0.0	mH	214748364.7	
<input checked="" type="checkbox"/> Read access <input type="checkbox"/> Write access <input type="checkbox"/> CINH <input type="checkbox"/> PLC STOP <input type="checkbox"/> No transfer			Scaling factor: 10

## C00080

Parameter   Name: <b>C00080   Resolver - number of pole pairs</b>			Data type: UNSIGNED_32 Index: 24495 <sub>d</sub> = 5FAF <sub>h</sub>
			<a href="#">▶ Adaptation of the resolver evaluation dynamics</a> <a href="#">▶ Homing</a> <a href="#">▶ Behaviour of the home position after mains switching</a>
<b>Setting range (min. value   unit   max. value)</b>			<b>Lenze setting</b>
1		10	<b>1</b>
<input checked="" type="checkbox"/> Read access <input checked="" type="checkbox"/> Write access <input checked="" type="checkbox"/> CINH <input type="checkbox"/> PLC STOP <input type="checkbox"/> No transfer			Scaling factor: 1

## C00081

Parameter   Name: <b>C00081   Rated motor power</b>			Data type: UNSIGNED_32 Index: 24494 <sub>d</sub> = 5FAE <sub>h</sub>
<b>Setting range (min. value   unit   max. value)</b>			<b>Lenze setting</b>
0.01	kW	500.00	<b>0.25 kW</b>
<input checked="" type="checkbox"/> Read access <input checked="" type="checkbox"/> Write access <input checked="" type="checkbox"/> CINH <input type="checkbox"/> PLC STOP <input type="checkbox"/> No transfer			Scaling factor: 100

## C00082

Parameter   Name: <b>C00082   Motor rotor resistance</b>			Data type: UNSIGNED_32 Index: 24493 <sub>d</sub> = 5FAD <sub>h</sub>
<b>Display range (min. value   unit   max. value)</b>			
0.0000	Ohm	214748.3647	
<input checked="" type="checkbox"/> Read access <input type="checkbox"/> Write access <input type="checkbox"/> CINH <input type="checkbox"/> PLC STOP <input type="checkbox"/> No transfer			Scaling factor: 10000

## C00083

Parameter   Name: <b>C00083   Motor rotor time constant</b>			Data type: UNSIGNED_32 Index: 24492 <sub>d</sub> = 5FAC <sub>h</sub>
<b>Display range (min. value   unit   max. value)</b>			
0.00	ms	21474836.47	
<input checked="" type="checkbox"/> Read access <input type="checkbox"/> Write access <input type="checkbox"/> CINH <input type="checkbox"/> PLC STOP <input type="checkbox"/> No transfer			Scaling factor: 100

## C00084

Parameter   Name: <b>C00084   Motor stator resistance</b>			Data type: UNSIGNED_32 Index: 24491 <sub>d</sub> = 5FAB <sub>h</sub>
Setting range (min. value   unit   max. value)			Lenze setting
0.0000	Ohm	125.0000	<b>18.2200 Ohm</b>
<input checked="" type="checkbox"/> Read access <input checked="" type="checkbox"/> Write access <input checked="" type="checkbox"/> CINH <input type="checkbox"/> PLC STOP <input type="checkbox"/> No transfer			Scaling factor: 10000

## C00085

Parameter   Name: <b>C00085   Motor stator leakage inductance</b>			Data type: UNSIGNED_32 Index: 24490 <sub>d</sub> = 5FAA <sub>h</sub>
Setting range (min. value   unit   max. value)			Lenze setting
0.000	mH	500.000	<b>51.000 mH</b>
<input checked="" type="checkbox"/> Read access <input checked="" type="checkbox"/> Write access <input checked="" type="checkbox"/> CINH <input type="checkbox"/> PLC STOP <input type="checkbox"/> No transfer			Scaling factor: 1000

## C00087

Parameter   Name: <b>C00087   Rated motor speed</b>			Data type: UNSIGNED_32 Index: 24488 <sub>d</sub> = 5FA8 <sub>h</sub>
Setting range (min. value   unit   max. value)			Lenze setting
50	rpm	50000	<b>4050 rpm</b>
<input checked="" type="checkbox"/> Read access <input checked="" type="checkbox"/> Write access <input checked="" type="checkbox"/> CINH <input type="checkbox"/> PLC STOP <input type="checkbox"/> No transfer			Scaling factor: 1

## C00088

Parameter   Name: <b>C00088   Rated motor current</b>			Data type: UNSIGNED_32 Index: 24487 <sub>d</sub> = 5FA7 <sub>h</sub>
Setting range (min. value   unit   max. value)			Lenze setting
0.01	A	1500.00	<b>1.30 A</b>
<input checked="" type="checkbox"/> Read access <input checked="" type="checkbox"/> Write access <input checked="" type="checkbox"/> CINH <input type="checkbox"/> PLC STOP <input type="checkbox"/> No transfer			Scaling factor: 100

## C00089

Parameter   Name: <b>C00089   Rated motor frequency</b>			Data type: UNSIGNED_32 Index: 24486 <sub>d</sub> = 5FA6 <sub>h</sub>
Setting range (min. value   unit   max. value)			Lenze setting
0.1	Hz	1000.0	<b>270.0 Hz</b>
<input checked="" type="checkbox"/> Read access <input checked="" type="checkbox"/> Write access <input checked="" type="checkbox"/> CINH <input type="checkbox"/> PLC STOP <input type="checkbox"/> No transfer			Scaling factor: 10

## C00090

Parameter   Name: <b>C00090   Rated motor voltage</b>			Data type: UNSIGNED_32 Index: 24485 <sub>d</sub> = 5FA5 <sub>h</sub>
Setting range (min. value   unit   max. value)			Lenze setting
50	V	15000	<b>225 V</b>
<input checked="" type="checkbox"/> Read access <input checked="" type="checkbox"/> Write access <input checked="" type="checkbox"/> CINH <input type="checkbox"/> PLC STOP <input type="checkbox"/> No transfer			Scaling factor: 1



## C00091

Parameter   Name: <b>C00091   Motor cosine phi</b>		Data type: UNSIGNED_32 Index: 24484 <sub>d</sub> = 5FA4 <sub>h</sub>	
<b>Setting range (min. value   unit   max. value)</b>		<b>Lenze setting</b>	
0.50		1.00	<b>0.80</b>
<input checked="" type="checkbox"/> Read access <input checked="" type="checkbox"/> Write access <input checked="" type="checkbox"/> CINH <input type="checkbox"/> PLC STOP <input type="checkbox"/> No transfer		Scaling factor: 100	

## C00092

Parameter   Name: <b>C00092   Motor - magnetising current</b>		Data type: UNSIGNED_32 Index: 24483 <sub>d</sub> = 5FA3 <sub>h</sub>	
<b>Display range (min. value   unit   max. value)</b>			
0.00	A	500.00	
<input checked="" type="checkbox"/> Read access <input type="checkbox"/> Write access <input type="checkbox"/> CINH <input type="checkbox"/> PLC STOP <input type="checkbox"/> No transfer		Scaling factor: 100	

## C00093

Parameter   Name: <b>C00093   Field weakening for SM</b>		Data type: UNSIGNED_32 Index: 24482 <sub>d</sub> = 5FA2 <sub>h</sub>	
From software version V2.0 onwards			
<a href="#">► Field weakening for synchronous machines</a>			
<b>Selection list (Lenze setting printed in bold)</b>			
0	<b>Field weakening for SM off</b>		
1	Field weakening for SM on		
<input checked="" type="checkbox"/> Read access <input checked="" type="checkbox"/> Write access <input type="checkbox"/> CINH <input type="checkbox"/> PLC STOP <input type="checkbox"/> No transfer		Scaling factor: 1	

## C00099

Parameter   Name: <b>C00099   Firmware version</b>		Data type: VISIBLE_STRING Index: 24476 <sub>d</sub> = 5F9C <sub>h</sub>	
Format: "xx.xx.xx.xx" (main version, subversion, release version, build number)			
<input checked="" type="checkbox"/> Read access <input type="checkbox"/> Write access <input type="checkbox"/> RSP <input type="checkbox"/> PLC-STOP <input type="checkbox"/> No transfer		Scaling factor: 1 Character length: 12	

## C00100

Parameter   Name: <b>C00100   Resol. of an encoder revolution</b>		Data type: UNSIGNED_32 Index: 24475 <sub>d</sub> = 5F9B <sub>h</sub>	
<b>Setting range (min. value   unit   max. value)</b>		<b>Lenze setting</b>	
10		24	<b>16</b>
<input checked="" type="checkbox"/> Read access <input checked="" type="checkbox"/> Write access <input checked="" type="checkbox"/> CINH <input type="checkbox"/> PLC STOP <input type="checkbox"/> No transfer		Scaling factor: 1	

## C00105

Parameter   Name: <b>C00105   Decel. time - quick stop</b>		Data type: UNSIGNED_32 Index: 24470 <sub>d</sub> = 5F96 <sub>h</sub>	
Time between quick stop activation and standstill plus relative S-ramp time ( <a href="#">C00106</a> ).			
<a href="#">► Basic function "Quick stop"</a>			
<b>Setting range (min. value   unit   max. value)</b>		<b>Lenze setting</b>	
0.000	s	999.999	<b>0.000 s</b>
<input checked="" type="checkbox"/> Read access <input checked="" type="checkbox"/> Write access <input type="checkbox"/> CINH <input type="checkbox"/> PLC STOP <input type="checkbox"/> No transfer		Scaling factor: 1000	

## C00106

Parameter   Name: <b>C00106   Quick stop S-ramp time</b>		Data type: UNSIGNED_32 Index: 24469 <sub>d</sub> = 5F95 <sub>h</sub>	
S-ramp time in [%] relating to the deceleration time set under <a href="#">C00105</a> .			
▶ Basic function " <a href="#">Quick stop</a> "			
Setting range (min. value   unit   max. value)		Lenze setting	
0.00	%	100.00	<b>0.00 %</b>
<input checked="" type="checkbox"/> Read access <input checked="" type="checkbox"/> Write access <input type="checkbox"/> CINH <input type="checkbox"/> PLC STOP <input type="checkbox"/> No transfer		Scaling factor: 100	

## C00107

Parameter   Name: <b>C00107   Ref. for quick stop dec. time</b>		Data type: UNSIGNED_8 Index: 24468 <sub>d</sub> = 5F94 <sub>h</sub>	
Reference for the deceleration time set in <a href="#">C00105</a> .			
▶ Basic function " <a href="#">Quick stop</a> "			
Selection list (Lenze setting printed in bold)			
0	<b>Motor reference speed (C00011)</b>		
1	Current speed		
<input checked="" type="checkbox"/> Read access <input checked="" type="checkbox"/> Write access <input type="checkbox"/> CINH <input type="checkbox"/> PLC STOP <input type="checkbox"/> No transfer		Scaling factor: 1	

## C00114

Parameter   Name: <b>C00114   Dig. input x: Terminal polarity</b>		Data type: UNSIGNED_8 Index: 24461 <sub>d</sub> = 5F8D <sub>h</sub>	
"0" = positive logic (HIGH level = TRUE, LOW level = FALSE) "1" = negative logic (HIGH level = FALSE, LOW level = TRUE)			
Setting range (min. value   unit   max. value)			
0		1	
Subcodes	Lenze setting	Info	
C00114/1	0	Terminal polarity - digital input 1 ... 8	
C00114/...			
C00114/8			
<input checked="" type="checkbox"/> Read access <input checked="" type="checkbox"/> Write access <input type="checkbox"/> CINH <input type="checkbox"/> PLC STOP <input type="checkbox"/> No transfer		Scaling factor: 1	

## C00118

Parameter   Name: <b>C00118   Dig. output. x: Terminal polarity</b>		Data type: UNSIGNED_8 Index: 24457 <sub>d</sub> = 5F89 <sub>h</sub>	
"0" ≡ positive logic (TRUE ≡ HIGH level, FALSE ≡ LOW level) "1" ≡ negative logic (FALSE ≡ HIGH level, TRUE ≡ LOW level)			
Setting range (min. value   unit   max. value)			
0		1	
Subcodes	Lenze setting	Info	
C00118/1	0	Terminal polarity - digital output 1 ... 4	
C00118/...			
C00118/4			
<input checked="" type="checkbox"/> Read access <input checked="" type="checkbox"/> Write access <input type="checkbox"/> CINH <input type="checkbox"/> PLC STOP <input type="checkbox"/> No transfer		Scaling factor: 1	

## C00120

Parameter   Name: <b>C00120   Mot. overload protection (I<sup>2</sup>t)</b>		Data type: UNSIGNED_32 Index: 24455 <sub>d</sub> = 5F87 <sub>h</sub>	
Threshold for I <sup>2</sup> x t disconnection <ul style="list-style-type: none"> <li>• Disconnection is carried out if the thermal motor load (<a href="#">C00066</a>) is higher than the set threshold.</li> <li>• A 100 % thermal motor load corresponds to a permanently flowing rated motor current</li> </ul> <b>Note:</b> When the value is parameterised to 200 %, the monitoring mode of the motor overload protection is switched off! <a href="#">▶ I<sup>2</sup>x t motor monitoring</a>			
<b>Setting range (min. value   unit   max. value)</b>		<b>Lenze setting</b>	
0	%	200	<b>105 %</b>
<input checked="" type="checkbox"/> Read access <input checked="" type="checkbox"/> Write access <input type="checkbox"/> CINH <input type="checkbox"/> PLC STOP <input type="checkbox"/> No transfer		Scaling factor: 1	

## C00121

Parameter   Name: <b>C00121   Warning threshold motor temperature</b>		Data type: UNSIGNED_32 Index: 24454 <sub>d</sub> = 5F86 <sub>h</sub>	
Temperature threshold for motor temperature advance warning <ul style="list-style-type: none"> <li>• The response to reaching the threshold can be selected in <a href="#">C00584</a>.</li> </ul> <a href="#">▶ Motor temperature monitoring</a>			
<b>Setting range (min. value   unit   max. value)</b>		<b>Lenze setting</b>	
0	°C	150	<b>120 °C</b>
<input checked="" type="checkbox"/> Read access <input checked="" type="checkbox"/> Write access <input type="checkbox"/> CINH <input type="checkbox"/> PLC STOP <input type="checkbox"/> No transfer		Scaling factor: 1	

## C00122

Parameter   Name: <b>C00122   Heatsink temp. warn. threshold</b>		Data type: UNSIGNED_32 Index: 24453 <sub>d</sub> = 5F85 <sub>h</sub>	
Temperature threshold for heatsink temperature advance warning <ul style="list-style-type: none"> <li>• The response to reaching the threshold can be selected in <a href="#">C00582</a>.</li> </ul>			
<b>Setting range (min. value   unit   max. value)</b>		<b>Lenze setting</b>	
0	°C	85	<b>85 °C</b>
<input checked="" type="checkbox"/> Read access <input checked="" type="checkbox"/> Write access <input type="checkbox"/> CINH <input type="checkbox"/> PLC STOP <input type="checkbox"/> No transfer		Scaling factor: 1	

## C00123

Parameter   Name: <b>C00123   Warning threshold device util.</b>		Data type: UNSIGNED_32 Index: 24452 <sub>d</sub> = 5F84 <sub>h</sub>	
Adjustable threshold for I x t advance warning <ul style="list-style-type: none"> <li>• The advance warning is sent if the device utilisation (<a href="#">C00064</a>) is higher than the set threshold.</li> <li>• The response for reaching the threshold can be selected in <a href="#">C00604</a>.</li> </ul>			
<b>Setting range (min. value   unit   max. value)</b>		<b>Lenze setting</b>	
0	%	100	<b>90 %</b>
<input checked="" type="checkbox"/> Read access <input checked="" type="checkbox"/> Write access <input type="checkbox"/> CINH <input type="checkbox"/> PLC STOP <input type="checkbox"/> No transfer		Scaling factor: 1	

## C00126

Parameter   Name: <b>C00126   CPU temp. warning threshold</b>		Data type: UNSIGNED_32 Index: 24449 <sub>d</sub> = 5F81 <sub>h</sub>	
Temperature threshold for advance warning of CPU temperature on the control card <ul style="list-style-type: none"> <li>The response to reaching the threshold can be selected in <a href="#">C00589</a>.</li> </ul>			
Setting range (min. value   unit   max. value)		Lenze setting	
0	°C	85	70 °C
<input checked="" type="checkbox"/> Read access <input checked="" type="checkbox"/> Write access <input type="checkbox"/> CINH <input type="checkbox"/> PLC STOP <input type="checkbox"/> No transfer		Scaling factor: 1	

## C00127

Parameter   Name: <b>C00127   Mot. overload warning threshold</b>		Data type: UNSIGNED_32 Index: 24448 <sub>d</sub> = 5F80 <sub>h</sub>	
Adjustable threshold for I <sup>2</sup> x t advance warning <ul style="list-style-type: none"> <li>The advance warning is sent if the thermal motor load (<a href="#">C00066</a>) is higher than the set threshold.</li> <li>The response for reaching the threshold can be selected in <a href="#">C00606</a>.</li> </ul> <p style="text-align: right;">▶ <a href="#">I2xt motor monitoring</a></p>			
Setting range (min. value   unit   max. value)		Lenze setting	
0	%	200	100 %
<input checked="" type="checkbox"/> Read access <input checked="" type="checkbox"/> Write access <input type="checkbox"/> CINH <input type="checkbox"/> PLC STOP <input type="checkbox"/> No transfer		Scaling factor: 1	

## C00128

Parameter   Name: <b>C00128   Therm. motor time constant</b>		Data type: UNSIGNED_32 Index: 24447 <sub>d</sub> = 5F7F <sub>h</sub>	
▶ <a href="#">I2xt motor monitoring</a>			
Setting range (min. value   unit   max. value)			
0.1	min	600.0	
Subcodes	Lenze setting	Info	
C00128/1	1.0 min	Therm. time constant coil	
C00128/2	5.0 min	Therm. time constant plates	
<input checked="" type="checkbox"/> Read access <input checked="" type="checkbox"/> Write access <input type="checkbox"/> CINH <input type="checkbox"/> PLC STOP <input type="checkbox"/> No transfer		Scaling factor: 10	

## C00129

Parameter   Name: <b>C00129   Brake resistance value</b>		Data type: INTEGER_32 Index: 24446 <sub>d</sub> = 5F7E <sub>h</sub>	
Required for monitoring of the brake resistor temperature. <p style="text-align: right;">▶ <a href="#">Braking operation</a></p>			
Setting range (min. value   unit   max. value)		Lenze setting	
0.0	Ohm	500.0	180.0 Ohm
<input checked="" type="checkbox"/> Read access <input checked="" type="checkbox"/> Write access <input type="checkbox"/> CINH <input type="checkbox"/> PLC STOP <input type="checkbox"/> No transfer		Scaling factor: 10	

## C00130

Parameter   Name: <b>C00130   Rated power - brake resistor</b>			Data type: INTEGER_32 Index: 24445 <sub>d</sub> = 5F7D <sub>h</sub>
Required for monitoring of the brake resistor temperature.			<a href="#">▶ Braking operation</a>
Setting range (min. value   unit   max. value)		Lenze setting	
0	W	800000	<b>5600 W</b>
<input checked="" type="checkbox"/> Read access <input checked="" type="checkbox"/> Write access <input type="checkbox"/> CINH <input type="checkbox"/> PLC STOP <input type="checkbox"/> No transfer			Scaling factor: 1

## C00131

Parameter   Name: <b>C00131 - Rated quantity of heat for brake res.</b>			Data type: INTEGER_32 Index: 24444 <sub>d</sub> = 5F7C <sub>h</sub>
Required for monitoring of the brake resistor temperature.			<a href="#">▶ Braking operation</a>
Setting range (min. value   unit   max. value)		Lenze setting	
0	kWs	100000	<b>485 kWs</b>
<input checked="" type="checkbox"/> Read access <input checked="" type="checkbox"/> Write access <input type="checkbox"/> CINH <input type="checkbox"/> PLC STOP <input type="checkbox"/> No transfer			Scaling factor: 1

## C00132

Parameter   Name: <b>C00132   Service code</b>			Data type: INTEGER_32 Index: 24443 <sub>d</sub> = 5F7B <sub>h</sub>
<b>This code is for device-internal use only and must not be written to by the user!</b>			

## C00133

Parameter   Name: <b>C00133   Ref.: Brake chopper utilisation</b>			Data type: UNSIGNED_8 Index: 24442 <sub>d</sub> = 5F7A <sub>h</sub>
From software version V1.5			<a href="#">▶ Braking operation</a>
Selection list (Lenze setting printed in bold)		Info	
<b>0</b>	<b>Minimum resistance (C00134)</b>	<a href="#">▶ C00134</a>	
1	Resistance in C00129	<a href="#">▶ C00129</a>	
<input checked="" type="checkbox"/> Read access <input checked="" type="checkbox"/> Write access <input type="checkbox"/> CINH <input type="checkbox"/> PLC STOP <input type="checkbox"/> No transfer			Scaling factor: 1

## C00134

Parameter   Name: <b>C00134   Minimum brake resistance</b>			Data type: INTEGER_32 Index: 24441 <sub>d</sub> = 5F79 <sub>h</sub>
From software version V1.5			<a href="#">▶ Braking operation</a>
Display range (min. value   unit   max. value)			
0.0	Ohm	500.0	
<input checked="" type="checkbox"/> Read access <input type="checkbox"/> Write access <input type="checkbox"/> CINH <input type="checkbox"/> PLC STOP <input type="checkbox"/> No transfer			Scaling factor: 10

## C00137

Parameter   Name: <b>C00137   Brake transistor utilisation</b>		Data type: INTEGER_32 Index: 24438 <sub>d</sub> = 5F76 <sub>h</sub>
From software version V1.5		<a href="#">▶ Braking operation</a>
<b>Display range (min. value   unit   max. value)</b>		
0	%	250
<input checked="" type="checkbox"/> Read access <input type="checkbox"/> Write access <input type="checkbox"/> CINH <input type="checkbox"/> PLC STOP <input type="checkbox"/> No transfer		Scaling factor: 1

## C00138

Parameter   Name: <b>C00138   Brake resistor utilisation</b>		Data type: INTEGER_32 Index: 24437 <sub>d</sub> = 5F75 <sub>h</sub>
From software version V1.5		<a href="#">▶ Braking operation</a>
<b>Display range (min. value   unit   max. value)</b>		
0	%	250
<input checked="" type="checkbox"/> Read access <input type="checkbox"/> Write access <input type="checkbox"/> CINH <input type="checkbox"/> PLC STOP <input type="checkbox"/> No transfer		Scaling factor: 1

## C00142

Parameter   Name: <b>C00142   Autom. restart after mains ON</b>		Data type: UNSIGNED_32 Index: 24433 <sub>d</sub> = 5F71 <sub>h</sub>
Starting performance of the controller after mains connection and reset of "Trouble", "Fault" or "Safe torque off active".		
<p><b>⚠ Danger!</b></p> <ul style="list-style-type: none"> <li>If automatic restart is enabled (<a href="#">C00142</a> = "1: Enabled"), the drive can restart automatically from the "Trouble" and "Safe torque off" device states when the trouble or request for "Safe torque off active" has been eliminated!</li> <li>The controller enable generated by the application via a connection of the terminal 28 (RFR) with one of the digital outputs <i>DIGOUT_bOut(x)</i> is not permissible if the following functions are active: "Auto-start after mains ON" (<a href="#">C00142</a> = "1") and "Program auto-start after mains switching" (<a href="#">C02104</a> = "1") <b>If this is not observed, the controller can start automatically after mains connection!</b></li> </ul>		
		<a href="#">▶ Automatic restart after mains connection</a> <a href="#">▶ Activate application</a>
<b>Selection list (Lenze setting printed in bold)</b>		
<b>0</b>	<b>Blocked</b>	
1	Released	
<input checked="" type="checkbox"/> Read access <input checked="" type="checkbox"/> Write access <input type="checkbox"/> CINH <input type="checkbox"/> PLC STOP <input type="checkbox"/> No transfer		Scaling factor: 1

C00150

Parameter   Name: <b>C00150   Status word device control 1</b>		Data type: BITFIELD_16 Index: 24425 <sub>d</sub> = 5F69 <sub>h</sub>
Status word 1 of the <a href="#">drive interface</a>		
<b>Display area</b>		
0x0000		0xFFFF
<b>Value is bit-coded:</b>		<b>Info</b>
Bit 0	Reserved	For the meaning of bits 8 ... 11 see chapter " <a href="#">Device states</a> ".
Bit 1	Pulse inhibit active	
Bit 2	Reserved	
Bit 3	Reserved	
Bit 4	Reserved	
Bit 5	Reserved	
Bit 6	Actual speed value = 0	
Bit 7	Controller inhibit active	
Bit 8	Device state - Bit 1	
Bit 9	Device state - Bit 2	
Bit 10	Device state - Bit 3	
Bit 11	Device state - Bit 4	
Bit 12	Warning is active	
Bit 13	Trouble active	
Bit 14	Reserved	
Bit 15	Reserved	
<input checked="" type="checkbox"/> Read access <input type="checkbox"/> Write access <input type="checkbox"/> CINH <input type="checkbox"/> PLC STOP <input type="checkbox"/> No transfer                   Scaling factor: 1		

C00155

Parameter   Name: <b>C00155   Status word device control 2</b>		Data type: BITFIELD_16 Index: 24420 <sub>d</sub> = 5F64 <sub>h</sub>
Status word 2 of the <a href="#">drive interface</a>		
<b>Display area</b>		
0x0000		0xFFFF
<b>Value is bit-coded:</b>		
Bit 0	Error status active	
Bit 1	Torque limit reached	
Bit 2	Current limit reached	
Bit 3	Reserved	
Bit 4	Drive switched on/in operation	
Bit 5	Drive ready for operation	
Bit 6	Fault active	
Bit 7	Drive initialisation	
Bit 8	Motor CCW rotation active	
Bit 9	Quick stop by trouble active	
Bit 10	Safe torque off active	
Bit 11	Application active	
Bit 12	Reserved	
Bit 13	Reserved	
Bit 14	Quick stop active	
Bit 15	Reserved	
<input checked="" type="checkbox"/> Read access <input type="checkbox"/> Write access <input type="checkbox"/> CINH <input type="checkbox"/> PLC STOP <input type="checkbox"/> No transfer		Scaling factor: 1

C00156

Parameter   Name: <b>C00156   Status/Control word MCTRL</b>		Data type: UNSIGNED_32 Index: 24419 <sub>d</sub> = 5F63 <sub>h</sub>
Status and control word of the <a href="#">motor interface</a>		
<b>Display range (min. value   unit   max. value)</b>		
0		4294967295
<b>Subcodes</b>		<b>Info</b>
C00156/1		Status word motor control
C00156/2		Control word motor control
<input checked="" type="checkbox"/> Read access <input type="checkbox"/> Write access <input type="checkbox"/> CINH <input type="checkbox"/> PLC STOP <input type="checkbox"/> No transfer		Scaling factor: 1



C00158

Parameter   Name: <b>C00158   Controller inhibit by (source)</b>		Data type: BITFIELD_16 Index: 24417 <sub>d</sub> = 5F61 <sub>h</sub>
Display of the sources for controller inhibit		
<b>Display area</b>		
0x0000		0xFFFF
<b>Value is bit-coded:</b>		
Bit 0	Terminal	
Bit 1	Reserved	
Bit 2	Reserved	
Bit 3	Reserved	
Bit 4	Application	
Bit 5	Device command	
Bit 6	Error response	
Bit 7	Internal PLC	
Bit 8	Reserved	
Bit 9	Energy saving mode	
Bit 10	Operating system	
Bit 11	Identification program	
Bit 12	Brake	
Bit 13	Limiter	
Bit 14	PPI	
Bit 15	Reserved	
<input checked="" type="checkbox"/> Read access <input type="checkbox"/> Write access <input type="checkbox"/> CINH <input type="checkbox"/> PLC STOP <input type="checkbox"/> No transfer		Scaling factor: 1

C00159

Parameter   Name: <b>C00159   Quick stop by (source)</b>		Data type: BITFIELD_16 Index: 24416 <sub>d</sub> = 5F60 <sub>h</sub>
<b>Display area</b>		
0x0000		0xFFFF
<b>Value is bit-coded:</b>		
Bit 0	Reserved	
Bit 1	Reserved	
Bit 2	Reserved	
Bit 3	Reserved	
Bit 4	Application	
Bit 5	Device command	
Bit 6	Error response	
Bit 7	Internal PLC	
Bit 8	Reserved	
Bit 9	Reserved	
Bit 10	Reserved	
Bit 11	Reserved	
Bit 12	Reserved	
Bit 13	Reserved	
Bit 14	Reserved	
Bit 15	Reserved	
<input checked="" type="checkbox"/> Read access <input type="checkbox"/> Write access <input type="checkbox"/> CINH <input type="checkbox"/> PLC STOP <input type="checkbox"/> No transfer                   Scaling factor: 1		

C00162

Parameter   Name: <b>C00162   Masked Error number</b>		Data type: UNSIGNED_32 Index: 24413 <sub>d</sub> = 5F5D <sub>h</sub>
From software version V5.0 Display of the individual components of the error number shown in <a href="#">C00168</a> .		
<b>Display range (min. value   unit   max. value)</b>		
0		4294967295
<b>Subcodes</b>		<b>Info</b>
C00162/1		Module ID + error number • As described in the chapter " <a href="#">Error messages</a> ".
C00162/2		Instance number
C00162/3		Error response
<input checked="" type="checkbox"/> Read access <input type="checkbox"/> Write access <input type="checkbox"/> CINH <input type="checkbox"/> PLC STOP <input type="checkbox"/> No transfer                   Scaling factor: 1		

C00166

Parameter   Name: <b>C00166   Error description</b>		Data type: VISIBLE_STRING Index: 24409 <sub>d</sub> = 5F59 <sub>h</sub>
Error description for error number indicated in <a href="#">C00168</a>		
<input checked="" type="checkbox"/> Read access <input type="checkbox"/> Write access <input type="checkbox"/> RSP <input type="checkbox"/> PLC-STOP <input type="checkbox"/> No transfer                   Scaling factor: 1                   Character length: 64		

## C00167

Parameter   Name: <b>C00167   Service code</b>	Data type: VISIBLE_STRING Index: 24408 <sub>d</sub> = 5F58 <sub>h</sub>
<b>This code is for device-internal use only and must not be written to by the user!</b>	

## C00168

Parameter   Name: <b>C00168   Error number</b>	Data type: UNSIGNED_32 Index: 24407 <sub>d</sub> = 5F57 <sub>h</sub>
Display of the error number of the first error with highest priority	
<b>Display range (min. value   unit   max. value)</b>	
0	4294967295
<input checked="" type="checkbox"/> Read access <input type="checkbox"/> Write access <input type="checkbox"/> CINH <input type="checkbox"/> PLC STOP <input type="checkbox"/> No transfer           Scaling factor: 1	

## C00169

Parameter   Name: <b>C00169   Logbook - event filter</b>	Data type: BITFIELD_32 Index: 24406 <sub>d</sub> = 5F56 <sub>h</sub>
Bit coded word for filtering system events (trouble, warning, information) <ul style="list-style-type: none"> <li>• A set filter bit inhibits entry of the corresponding event into the logbook.</li> <li>• <a href="#">From software version V5.0</a> the option that identical consecutive entries ("Multiple entries") into the logbook are suppressed can be additionally activated via bit 0. Then only the time stamp of the last (latest) entry and the number of times the same event has occurred successively are saved.</li> </ul>	
<a href="#">▶ Logbook</a>	
<b>Setting range</b>	<b>Lenze setting</b>
0x00000000	0xFFFFFFFF <b>0x00000001</b> (decimal: 1)
<b>Value is bit-coded: (<input checked="" type="checkbox"/> = bit set)</b>	<b>Info</b>
Bit 0 <input checked="" type="checkbox"/> No multiple entries	Bits not listed are reserved for future extensions!
Bit 1 <input type="checkbox"/> Error	
Bit 2 <input type="checkbox"/> Fault	
Bit 3 <input type="checkbox"/> Quick stop by trouble	
Bit 4 <input type="checkbox"/> Warning locked	
Bit 5 <input type="checkbox"/> Warning	
Bit 6 <input type="checkbox"/> Information	
<input checked="" type="checkbox"/> Read access <input checked="" type="checkbox"/> Write access <input type="checkbox"/> CINH <input type="checkbox"/> PLC STOP <input type="checkbox"/> No transfer           Scaling factor: 1	

## C00171

Parameter   Name: <b>C00171   Service code</b>	Data type: UNSIGNED_32 Index: 24404 <sub>d</sub> = 5F54 <sub>h</sub>
<b>This code is for device-internal use only and must not be written to by the user!</b>	

## C00173

Parameter   Name: <b>C00173   Mains voltage</b>		Data type: UNSIGNED_8 Index: 24402 <sub>d</sub> = 5F52 <sub>h</sub>
Adjustment of the DC bus voltage thresholds <ul style="list-style-type: none"> <li>• Check during commissioning and adapt, if necessary.</li> <li>• All drive components connected via the DC bus must have the same thresholds.</li> <li>• For selection 0 ... 3, the undervoltage threshold is firmly defined depending on the device type (see "Rated data" chapter in the Hardware Manual).</li> </ul> <b>Note:</b> Altering this setting also has an impact on the permissible device utilisation! In the chapter "Rated data" of the hardware manual the device types and their permissible device utilisation at a certain mains voltage and switching frequency are specified.		
Selection list (Lenze setting printed in bold)		Info
0	230 V	Operation on 230 V mains <ul style="list-style-type: none"> <li>• Threshold for "Undervoltage on" = 200 V</li> <li>• Threshold for "Undervoltage off" = 225 V</li> <li>• Overvoltage threshold = 400 V</li> <li>• Brake chopper threshold = 390 V</li> </ul>
<b>1</b>	<b>400/415 V</b>	Operation on 400 V mains/415 V mains <ul style="list-style-type: none"> <li>• Threshold for "Undervoltage on" = 285 V (BF1 to BF7)</li> <li>• Threshold for "Undervoltage on" = 400 V (BF8 to BF10)</li> <li>• Threshold for "Undervoltage off" = 430 V</li> <li>• Overvoltage threshold = 800 V</li> <li>• Brake chopper threshold = 725 V</li> </ul>
2	460/480 V	Operation on 460 V mains/480 V mains <ul style="list-style-type: none"> <li>• Threshold for "Undervoltage on" = 490 V</li> <li>• Threshold for "Undervoltage off" = 535 V</li> <li>• Overvoltage threshold = 800 V</li> <li>• Brake chopper threshold = 765 V</li> </ul>
3	500 V	Operation on 500 V mains <ul style="list-style-type: none"> <li>• Threshold for "Undervoltage on" = 540 V</li> <li>• Threshold for "Undervoltage off" = 585 V</li> <li>• Overvoltage threshold = 800 V</li> <li>• Brake chopper threshold = 790 V</li> </ul>
4	230 V, LU configurable	Operation on 230 V mains <ul style="list-style-type: none"> <li>• Undervoltage threshold is defined in <a href="#">C00174</a>.</li> <li>• Overvoltage threshold = 400 V</li> <li>• Brake chopper threshold = 390 V</li> </ul>
5	400/415 V, LU configurable	Operation on 400 V mains/415 V mains <ul style="list-style-type: none"> <li>• Undervoltage threshold is defined in <a href="#">C00174</a>.</li> <li>• Overvoltage threshold = 800 V</li> <li>• Brake chopper threshold = 725 V</li> </ul>
6	460/480 V, LU configurable	Operation on 460 V mains/480 V mains <ul style="list-style-type: none"> <li>• Undervoltage threshold is defined in <a href="#">C00174</a>.</li> <li>• Overvoltage threshold = 800 V</li> <li>• Brake chopper threshold = 765 V</li> </ul>
7	500 V, LU configurable	Operation on 500 V mains <ul style="list-style-type: none"> <li>• Undervoltage threshold is defined in <a href="#">C00174</a>.</li> <li>• Overvoltage threshold = 800 V</li> <li>• Brake chopper threshold = 790 V</li> </ul>
<input checked="" type="checkbox"/> Read access <input checked="" type="checkbox"/> Write access <input type="checkbox"/> CINH <input type="checkbox"/> PLC STOP <input type="checkbox"/> No transfer		Scaling factor: 1

# 14 Parameter reference

## 14.2 Parameter list | C00174

### C00174

Parameter   Name: <b>C00174   Undervoltage (LU) threshold</b>		Data type: UNSIGNED_32 Index: 24401 <sub>d</sub> = 5F51 <sub>h</sub>	
When <a href="#">C00173</a> = 4 ... 7, the undervoltage threshold (LU) can be freely selected. <b>Note:</b> The minimum adjustable undervoltage threshold depends on the device type: <ul style="list-style-type: none"><li>• Single-axis controller (Single Drive) up to and including BF7: 210 V</li><li>• Single-axis controller (Single Drive) from BF8s: 400 V</li><li>• Multi-axis controller (Multi Drive): 15 V</li></ul> In the case of an offline parameter setting or when exchanging the memory module between different 9400 HighLine device types, always check the setting of this parameter and adapt it, if required, to prevent a parameter error after the parameter set download or module change!			
<b>Setting range (min. value   unit   max. value)</b>		<b>Lenze setting</b>	
15	V	400	<b>285 V</b>
<input checked="" type="checkbox"/> Read access <input checked="" type="checkbox"/> Write access <input type="checkbox"/> CINH <input type="checkbox"/> PLC STOP <input type="checkbox"/> No transfer		Scaling factor: 1	

### C00175

Parameter   Name: <b>C00175   Service code</b>		Data type: UNSIGNED_32 Index: 24400 <sub>d</sub> = 5F50 <sub>h</sub>
<b>This code is for device-internal use only and must not be written to by the user!</b>		

### C00176

Parameter   Name: <b>C00176   Service code</b>		Data type: UNSIGNED_32 Index: 24399 <sub>d</sub> = 5F4F <sub>h</sub>
<b>This code is for device-internal use only and must not be written to by the user!</b>		

### C00177

Parameter   Name: <b>C00177   Service code</b>		Data type: UNSIGNED_32 Index: 24398 <sub>d</sub> = 5F4E <sub>h</sub>
<b>This code is for device-internal use only and must not be written to by the user!</b>		

### C00178

Parameter   Name: <b>C00178   Elapsed-hour meter</b>		Data type: UNSIGNED_32 Index: 24397 <sub>d</sub> = 5F4D <sub>h</sub>
<b>Display range (min. value   unit   max. value)</b>		
0	s	4294967295
<input checked="" type="checkbox"/> Read access <input type="checkbox"/> Write access <input type="checkbox"/> CINH <input type="checkbox"/> PLC STOP <input type="checkbox"/> No transfer		Scaling factor: 1

### C00179

Parameter   Name: <b>C00179   Power-on time meter</b>		Data type: UNSIGNED_32 Index: 24396 <sub>d</sub> = 5F4C <sub>h</sub>
<b>Display range (min. value   unit   max. value)</b>		
0	s	4294967295
<input checked="" type="checkbox"/> Read access <input type="checkbox"/> Write access <input type="checkbox"/> CINH <input type="checkbox"/> PLC STOP <input type="checkbox"/> No transfer		Scaling factor: 1

## C00180

Parameter   Name: <b>C00180   Service code</b>	Data type: VISIBLE_STRING Index: 24395 <sub>d</sub> = 5F4B <sub>h</sub>
For Lenze service only	
<input checked="" type="checkbox"/> Read access <input checked="" type="checkbox"/> Write access <input type="checkbox"/> CINH <input type="checkbox"/> PLC STOP <input checked="" type="checkbox"/> No transfer           Character length: 192	

## C00181

Parameter   Name: <b>C00181   Red. brake chopper threshold</b>	Data type: UNSIGNED_32 Index: 24394 <sub>d</sub> = 5F4A <sub>h</sub>
<a href="#">▶ Braking operation</a>	
Setting range (min. value   unit   max. value)	Lenze setting
0                      V                      100	<b>0 V</b>
<input checked="" type="checkbox"/> Read access <input checked="" type="checkbox"/> Write access <input type="checkbox"/> CINH <input type="checkbox"/> PLC STOP <input type="checkbox"/> No transfer           Scaling factor: 1	

## C00182

Parameter   Name: <b>C00182   Time for device search function</b>	Data type: UNSIGNED_16 Index: 24393 <sub>d</sub> = 5F49 <sub>h</sub>
From software version V9.0	
Setting range (min. value   unit   max. value)	Lenze setting
0                                           6000	<b>5</b>
<input checked="" type="checkbox"/> Read access <input checked="" type="checkbox"/> Write access <input type="checkbox"/> CINH <input type="checkbox"/> PLC STOP <input type="checkbox"/> No transfer           Scaling factor: 1	

## C00183

Parameter   Name: <b>C00183   Device status</b>	Data type: UNSIGNED_32 Index: 24392 <sub>d</sub> = 5F48 <sub>h</sub>
Display of the device state for diagnostic purposes	
Selection list (read only)	
0	Operation
1	Operation/Warning active
2	Operation/warning locked act.
3	Operation/Quick stop active
4	Operation/Application stopped
10	Initialisation active
20	System fault active
90	Device is switched on
91	Device is switched on/QSP trouble
95	Device switched-on/energy saving mode
101	Safe torque off active
102	Fault active
104	Trouble active
141	Drive ready to start --> C00142
151	Quick stop by trouble active
<input checked="" type="checkbox"/> Read access <input type="checkbox"/> Write access <input type="checkbox"/> CINH <input type="checkbox"/> PLC STOP <input type="checkbox"/> No transfer           Scaling factor: 1	

## C00185

Parameter   Name: <b>C00185   Mains recov. detect. threshold</b>		Data type: UNSIGNED_32 Index: 24390 <sub>d</sub> = 5F46 <sub>h</sub>
<b>This code must not be written to by the user!</b>		
<b>Setting range</b> (min. value   unit   max. value)		<b>Lenze setting</b>
0	%	100
<input checked="" type="checkbox"/> Read access <input checked="" type="checkbox"/> Write access <input type="checkbox"/> CINH <input type="checkbox"/> PLC STOP <input type="checkbox"/> No transfer		Scaling factor: 1

## C00186

Parameter   Name: <b>C00186   ENP: Identified motor type</b>		Data type: VISIBLE_STRING Index: 24389 <sub>d</sub> = 5F45 <sub>h</sub>
Motor type read from the electronic nameplate (ENP)		
<input checked="" type="checkbox"/> Read access <input type="checkbox"/> Write access <input type="checkbox"/> CINH <input type="checkbox"/> PLC-STOP <input type="checkbox"/> No transfer		Scaling factor: 1 Character length: 19

## C00187

Parameter   Name: <b>C00187   ENP: Identified serial number</b>		Data type: VISIBLE_STRING Index: 24388 <sub>d</sub> = 5F44 <sub>h</sub>
Serial number read from the electronic nameplate (ENP)		
<input checked="" type="checkbox"/> Read access <input type="checkbox"/> Write access <input type="checkbox"/> CINH <input type="checkbox"/> PLC-STOP <input type="checkbox"/> No transfer		Scaling factor: 1 Character length: 22

## C00188

Parameter   Name: <b>C00188   ENP: Status</b>		Data type: UNSIGNED_8 Index: 24387 <sub>d</sub> = 5F43 <sub>h</sub>
<b>Selection list</b> (read only)		
0	No ENP found	
1	ENP data loaded	
2	Known ENP found	
3	ENP found but not read	
<input checked="" type="checkbox"/> Read access <input type="checkbox"/> Write access <input type="checkbox"/> CINH <input type="checkbox"/> PLC STOP <input type="checkbox"/> No transfer		Scaling factor: 1

## C00198

Parameter   Name: <b>C00198   Service code</b>		Data type: UNSIGNED_32 Index: 24377 <sub>d</sub> = 5F39 <sub>h</sub>
<b>This code is for device-internal use only and must not be written to by the user!</b>		

## C00199

Parameter   Name: <b>C00199   Device name</b>		Data type: VISIBLE_STRING Index: 24376 <sub>d</sub> = 5F38 <sub>h</sub>
Device name to be defined by the user (e.g. "Cross cutter" or "hoist axis 1") with max. 128 characters		
<input checked="" type="checkbox"/> Read access <input checked="" type="checkbox"/> Write access <input type="checkbox"/> CINH <input type="checkbox"/> PLC STOP <input type="checkbox"/> No transfer		Scaling factor: 1 Character length: 128

## C00200

Parameter   Name: <b>C00200   Firmware product type</b>		Data type: VISIBLE_STRING Index: 24375 <sub>d</sub> = 5F37 <sub>h</sub>
<input checked="" type="checkbox"/> Read access <input type="checkbox"/> Write access <input type="checkbox"/> CINH <input type="checkbox"/> PLC-STOP <input type="checkbox"/> No transfer		Scaling factor: 1 Character length: 18

## C00201

Parameter   Name: <b>C00201   Firmware - compiling date</b>	Data type: VISIBLE_STRING Index: 24374 <sub>d</sub> = 5F36 <sub>h</sub>
<input checked="" type="checkbox"/> Read access <input type="checkbox"/> Write access <input type="checkbox"/> CINH <input type="checkbox"/> PLC-STOP <input type="checkbox"/> No transfer           Scaling factor: 1           Character length: 21	

## C00202

Parameter   Name: <b>C00202   Autom. ENP data transfer</b>	Data type: UNSIGNED_32 Index: 24373 <sub>d</sub> = 5F35 <sub>h</sub>
From software version V1.5	
<b>Selection list (Lenze setting printed in bold)</b>	
0	Off
<b>1</b>	<b>On</b>
<input checked="" type="checkbox"/> Read access <input checked="" type="checkbox"/> Write access <input type="checkbox"/> CINH <input type="checkbox"/> PLC STOP <input type="checkbox"/> No transfer           Scaling factor: 1	

## C00203

Parameter   Name: <b>C00203   HW product types</b>	Data type: VISIBLE_STRING Index: 24372 <sub>d</sub> = 5F34 <sub>h</sub>
<b>Subcodes</b>	<b>Info</b>
C00203/1	Type: Control card
C00203/2	Type: Power section
C00203/3	Type: Module in MXI1
C00203/4	Type: Module in MXI2
C00203/5	Type: Memory module
C00203/6	Type: Safety module
C00203/7	Type: Standard device
C00203/8	Type: Complete device
C00203/9	Type: ENP
<input checked="" type="checkbox"/> Read access <input type="checkbox"/> Write access <input type="checkbox"/> CINH <input type="checkbox"/> PLC-STOP <input type="checkbox"/> No transfer           Scaling factor: 1           Character length: 18	

## C00204

Parameter   Name: <b>C00204   HW serial numbers</b>	Data type: VISIBLE_STRING Index: 24371 <sub>d</sub> = 5F33 <sub>h</sub>
<b>Subcodes</b>	<b>Info</b>
C00204/1	Serial no.: Control card
C00204/2	Serial no.: Power section
C00204/3	Serial no.: Module in MXI1
C00204/4	Serial no.: Module in MXI2
C00204/5	Serial no.: Memory module
C00204/6	Serial no.: Safety module
C00204/7	Serial no.: Standard device
C00204/8	Serial no.: Complete device
C00204/9	Serial no.: ENP
<input checked="" type="checkbox"/> Read access <input type="checkbox"/> Write access <input type="checkbox"/> CINH <input type="checkbox"/> PLC-STOP <input type="checkbox"/> No transfer           Scaling factor: 1           Character length: 22	



## C00205

Parameter   Name: C00205   HW descriptions		Data type: VISIBLE_STRING Index: 24370 <sub>d</sub> = 5F32 <sub>h</sub>
Subcodes	Info	
C00205/1	Info: Control card	
C00205/2	Info: Power section	
C00205/3	Info: Module in MXI1	
C00205/4	Info: Module in MXI2	
C00205/5	Info: Memory module	
C00205/6	Info: Safety module	
<input checked="" type="checkbox"/> Read access <input type="checkbox"/> Write access <input type="checkbox"/> CINH <input type="checkbox"/> PLC-STOP <input type="checkbox"/> No transfer		Scaling factor: 1   Character length: 18

## C00206

Parameter   Name: C00206   HW manufacturing data		Data type: VISIBLE_STRING Index: 24369 <sub>d</sub> = 5F31 <sub>h</sub>
Subcodes	Info	
C00206/1	Date: Control card	
C00206/2	Date: Power section	
C00206/3	Date: Module in MXI1	
C00206/4	Date: Module in MXI2	
C00206/5	Date: Memory module	
C00206/6	Date: Safety module	
C00206/7	Date: Standard device	
C00206/8	Date: Complete device	
<input checked="" type="checkbox"/> Read access <input type="checkbox"/> Write access <input type="checkbox"/> RSP <input type="checkbox"/> PLC-STOP <input type="checkbox"/> No transfer		Scaling factor: 1   Character length: 20

## C00208

Parameter   Name: C00208   HW manufacturer		Data type: VISIBLE_STRING Index: 24367 <sub>d</sub> = 5F2F <sub>h</sub>
Subcodes	Info	
C00208/1	Manufacturer: Control card	
C00208/2	Manufacturer: Power section	
C00208/3	Manufacturer: Module in MXI1	
C00208/4	Manufacturer: Module in MXI2	
C00208/5	Manufacturer: Memory module	
C00208/6	Manufacturer: Safety module	
<input checked="" type="checkbox"/> Read access <input type="checkbox"/> Write access <input type="checkbox"/> RSP <input type="checkbox"/> PLC-STOP <input type="checkbox"/> No transfer		Scaling factor: 1   Character length: 20

## C00209

Parameter   Name: <b>C00209   HW countries of origin</b>		Data type: VISIBLE_STRING Index: 24366 <sub>d</sub> = 5F2E <sub>h</sub>
Subcodes	Info	
C00209/1	Country: Control card	
C00209/2	Country: Power section	
C00209/3	Country: Module in MXI1	
C00209/4	Country: Module in MXI2	
C00209/5	Country: Memory module	
C00209/6	Country: Safety module	
<input checked="" type="checkbox"/> Read access <input type="checkbox"/> Write access <input type="checkbox"/> RSP <input type="checkbox"/> PLC-STOP <input type="checkbox"/> No transfer		Scaling factor: 1   Character length: 4

## C00210

Parameter   Name: <b>C00210   HW versions</b>		Data type: VISIBLE_STRING Index: 24365 <sub>d</sub> = 5F2D <sub>h</sub>
Subcodes	Info	
C00210/1	HW version: Control card	
C00210/2	HW version: Power section	
C00210/3	HW version: Module in MXI1	
C00210/4	HW version: Module in MXI2	
C00210/5	HW version: Memory module	
C00210/6	HW version: Safety module	
<input checked="" type="checkbox"/> Read access <input type="checkbox"/> Write access <input type="checkbox"/> RSP <input type="checkbox"/> PLC-STOP <input type="checkbox"/> No transfer		Scaling factor: 1   Character length: 5

## C00211

Parameter   Name: <b>C00211   Application: Version</b>		Data type: VISIBLE_STRING Index: 24364 <sub>d</sub> = 5F2C <sub>h</sub>
<input checked="" type="checkbox"/> Read access <input type="checkbox"/> Write access <input type="checkbox"/> RSP <input type="checkbox"/> PLC-STOP <input type="checkbox"/> No transfer		Scaling factor: 1   Character length: 12

## C00212

Parameter   Name: <b>C00212   Application: Type code</b>		Data type: VISIBLE_STRING Index: 24363 <sub>d</sub> = 5F2B <sub>h</sub>
<input checked="" type="checkbox"/> Read access <input type="checkbox"/> Write access <input type="checkbox"/> RSP <input type="checkbox"/> PLC-STOP <input type="checkbox"/> No transfer		Scaling factor: 1   Character length: 20

## C00213

Parameter   Name: <b>C00213   Application: Compiler date</b>		Data type: VISIBLE_STRING Index: 24362 <sub>d</sub> = 5F2A <sub>h</sub>
<input checked="" type="checkbox"/> Read access <input type="checkbox"/> Write access <input type="checkbox"/> CINH <input type="checkbox"/> PLC-STOP <input type="checkbox"/> No transfer		Scaling factor: 1   Character length: 21

## C00214

Parameter   Name: <b>C00214   Required safety module</b>		Data type: UNSIGNED_8 Index: 24361 <sub>d</sub> = 5F29 <sub>h</sub>
Setting of the expected safety module		
<ul style="list-style-type: none"> <li>If a different safety module is detected, a fault (trouble) will be activated. The fault can only be reset by mains switching.</li> </ul>		
<b>Selection list</b> (Lenze setting printed in bold)		
1	<b>SM0</b>	
2	SM100	
4	SM300	
5	SM301	
6	SM302	
<input checked="" type="checkbox"/> Read access <input checked="" type="checkbox"/> Write access <input checked="" type="checkbox"/> CINH <input type="checkbox"/> PLC STOP <input type="checkbox"/> No transfer		Scaling factor: 1

## C00217

Parameter   Name: <b>C00217   Parameter error information</b>		Data type: UNSIGNED_32 Index: 24358 <sub>d</sub> = 5F26 <sub>h</sub>
<b>This code is for device-internal use only and must not be written to by the user!</b>		

## C00218

Parameter   Name: <b>C00218   Application: ID number</b>		Data type: UNSIGNED_32 Index: 24357 <sub>d</sub> = 5F25 <sub>h</sub>
<b>Display range</b> (min. value   unit   max. value)		
0		0
<input checked="" type="checkbox"/> Read access <input type="checkbox"/> Write access <input type="checkbox"/> CINH <input type="checkbox"/> PLC STOP <input type="checkbox"/> No transfer		Scaling factor: 1

## C00219

Parameter   Name: <b>C00219   CAN/EPL device type</b>		Data type: UNSIGNED_32 Index: 24356 <sub>d</sub> = 5F24 <sub>h</sub>
<b>This code is for device-internal use only and must not be written to by the user!</b>		

## C00220

Parameter   Name: <b>C00220   Memory module Firmw. Rev.</b>		Data type: UNSIGNED_32 Index: 24355 <sub>d</sub> = 5F23 <sub>h</sub>
<b>Display range</b> (min. value   unit   max. value)		
0		2147483647
<input checked="" type="checkbox"/> Read access <input type="checkbox"/> Write access <input type="checkbox"/> CINH <input type="checkbox"/> PLC STOP <input type="checkbox"/> No transfer		Scaling factor: 1

## C00225

Parameter   Name: <b>C00225   Check configuration</b>		Data type: UNSIGNED_32 Index: 24350 <sub>d</sub> = 5F1E <sub>h</sub>
<b>This code is for device-internal use only and must not be written to by the user!</b>		

## C00227

Parameter   Name: <b>C00227   Behaviour due to change of parameter set</b>		Data type: UNSIGNED_32 Index: 24348 <sub>d</sub> = 5F1C <sub>h</sub>
From software version V5.0		
By selecting "1" in the corresponding subcode a module plugged into module slot MXI1 or MXI2 can be excepted from the parameter set changeover via the device command "Activate parameter set n".		
<ul style="list-style-type: none"> <li>• By this the parameter set changeover, in particular for active modules, is carried out much more quickly.</li> <li>• An exception from the parameter set changeover for instance is reasonable if different parameter sets are used (e. g. for different tools within the machine), but if the parameters are always the same for the module (e. g. communication parameters).</li> </ul>		
<b>Selection list</b> (Lenze setting printed in bold)		
0	Included	
1	Excluded	
<b>Subcodes</b>	<b>Lenze setting</b>	<b>Info</b>
C00227/1	0: Included	Change of parameter set: MXI1
C00227/2	0: Included	Change of parameter set: MXI2
<input checked="" type="checkbox"/> Read access <input checked="" type="checkbox"/> Write access <input type="checkbox"/> CINH <input type="checkbox"/> PLC STOP <input type="checkbox"/> No transfer		Scaling factor: 1

## C00254

Parameter   Name: <b>C00254   Phase controller gain</b>		Data type: UNSIGNED_32 Index: 24321 <sub>d</sub> = 5F01 <sub>h</sub>
<b>Setting range</b> (min. value   unit   max. value)		<b>Lenze setting</b>
0.00	1/s	1000.00
		<b>20.00 1/s</b>
<input checked="" type="checkbox"/> Read access <input checked="" type="checkbox"/> Write access <input type="checkbox"/> CINH <input type="checkbox"/> PLC STOP <input type="checkbox"/> No transfer		Scaling factor: 100

## C00270

Parameter   Name: <b>C00270   Freq. - current setpoint filter</b>		Data type: UNSIGNED_32 Index: 24305 <sub>d</sub> = 5EF1 <sub>h</sub>
▶ <a href="#">Set current setpoint filter (band-stop filter)</a>		
<b>Setting range</b> (min. value   unit   max. value)		
1.0	Hz	1000.0
<b>Subcodes</b>	<b>Lenze setting</b>	<b>Info</b>
C00270/1	200.0 Hz	Freq. - current setp. filter 1
C00270/2	400.0 Hz	Freq. - current setp. filter 2
<input checked="" type="checkbox"/> Read access <input checked="" type="checkbox"/> Write access <input type="checkbox"/> CINH <input type="checkbox"/> PLC STOP <input type="checkbox"/> No transfer		Scaling factor: 10

## C00271

Parameter   Name: <b>C00271   Width - current setp. filter</b>		Data type: UNSIGNED_32 Index: 24304 <sub>d</sub> = 5EF0 <sub>h</sub>
▶ <a href="#">Set current setpoint filter (band-stop filter)</a>		
<b>Setting range</b> (min. value   unit   max. value)		
0.0	Hz	500.0
<b>Subcodes</b>	<b>Lenze setting</b>	<b>Info</b>
C00271/1	20.0 Hz	Width current setp. filter 1
C00271/2	40.0 Hz	Width current setp. filter 2
<input checked="" type="checkbox"/> Read access <input checked="" type="checkbox"/> Write access <input type="checkbox"/> CINH <input type="checkbox"/> PLC STOP <input type="checkbox"/> No transfer		Scaling factor: 10

## C00272

Parameter   Name: <b>C00272   Depth - current setp. filter</b>		Data type: UNSIGNED_32 Index: 24303 <sub>d</sub> = 5EEF <sub>h</sub>
The setting "0 dB" deactivates the current setpoint filter. <a href="#">▶ Set current setpoint filter (band-stop filter)</a>		
<b>Setting range (min. value   unit   max. value)</b>		
0	db	100
<b>Subcodes</b>	<b>Lenze setting</b>	<b>Info</b>
C00272/1	0 db	Depth current setp. filter 1
C00272/2	0 db	Depth current setp. filter 2
<input checked="" type="checkbox"/> Read access <input checked="" type="checkbox"/> Write access <input type="checkbox"/> CINH <input type="checkbox"/> PLC STOP <input type="checkbox"/> No transfer		Scaling factor: 1

## C00273

Parameter   Name: <b>C00273   Moment of inertia</b>		Data type: UNSIGNED_32 Index: 24302 <sub>d</sub> = 5EEE <sub>h</sub>
<b>Note:</b> The load moment of inertia must be set with regard to the motor end (i.e. considering the gearbox factors).		
<b>Setting range (min. value   unit   max. value)</b>		
0.00	kg cm <sup>2</sup>	20000000.00
<b>Subcodes</b>	<b>Lenze setting</b>	<b>Info</b>
C00273/1	0.14 kg cm <sup>2</sup>	Motor moment of inertia
C00273/2	0.00 kg cm <sup>2</sup>	Load moment of inertia
<input checked="" type="checkbox"/> Read access <input checked="" type="checkbox"/> Write access <input type="checkbox"/> CINH <input type="checkbox"/> PLC STOP <input type="checkbox"/> No transfer		Scaling factor: 100

## C00274

Parameter   Name: <b>C00274   Max. acceleration change</b>		Data type: UNSIGNED_32 Index: 24301 <sub>d</sub> = 5EED <sub>h</sub>
<b>Setting range (min. value   unit   max. value)</b>		<b>Lenze setting</b>
0.0	%/ms	400.0 <b>400.0 %/ms</b>
<input checked="" type="checkbox"/> Read access <input checked="" type="checkbox"/> Write access <input type="checkbox"/> CINH <input type="checkbox"/> PLC STOP <input type="checkbox"/> No transfer		Scaling factor: 10

## C00275

Parameter   Name: <b>C00275   Signal source - speed setpoint</b>		Data type: UNSIGNED_16 Index: 24300 <sub>d</sub> = 5EEC <sub>h</sub>
<b>Selection list (Lenze setting printed in bold)</b>		
0	<b>SpeedAdd signal</b>	
1	Differentiated PosSet signal	
<input checked="" type="checkbox"/> Read access <input checked="" type="checkbox"/> Write access <input type="checkbox"/> CINH <input type="checkbox"/> PLC STOP <input type="checkbox"/> No transfer		Scaling factor: 1

## C00276

Parameter   Name: <b>C00276   Signal source - torque setpoint</b>		Data type: UNSIGNED_16 Index: 24299 <sub>d</sub> = 5EEB <sub>h</sub>
Selection list (Lenze setting printed in bold)		Info
<b>0</b>	<b>TorqueAdd/AccAdd signal</b>	
1	Differentiated SpeedSet signal	
2	2x diff. PosSet signal	This setting only exists due to compatibility reasons and should not be used anymore. Use the setting 3 instead: "Differentiated SpeedAdd signal" that both can be used for the FB <b>LS_SpeedFollower</b> and the FB <b>LS_PositionFollower</b> .
3	Differentiated SpeedAdd signal	<b>From software version V5.0</b> This alternative selection to the differentiated SpeedSet signal is recommended if the position controller works with a high gain. By the position controller also troubles within to the actual position value are detected and like this reach the speed setpoint. In the following differentiation of the feedforward control, these troubles in particular in the case of high position controller gains result in a very unsettled torque feedforward control value. By means of this selection the problem can be avoided, because then only the trouble-free speed feedforward control value is differentiated.
<input checked="" type="checkbox"/> Read access <input checked="" type="checkbox"/> Write access <input type="checkbox"/> CINH <input type="checkbox"/> PLC STOP <input type="checkbox"/> No transfer		Scaling factor: 1

## C00280

Parameter   Name: <b>C00280   Filter time const. DC detection</b>			Data type: UNSIGNED_32 Index: 24295 <sub>d</sub> = 5EE7 <sub>h</sub>
Setting range (min. value   unit   max. value)		Lenze setting	
1.0	ms	1000.0	<b>25.0 ms</b>
<input checked="" type="checkbox"/> Read access <input checked="" type="checkbox"/> Write access <input type="checkbox"/> CINH <input type="checkbox"/> PLC STOP <input type="checkbox"/> No transfer			Scaling factor: 10

## C00281

Parameter   Name: <b>C00281   Filter for PWM adjustment</b>		Data type: UNSIGNED_8 Index: 24294 <sub>d</sub> = 5EE6 <sub>h</sub>
<b>From software version V7.0</b>		
<p>The output voltage of the inverter is generated from the DC-bus voltage by a pulse width modulation (PWM). The product from the DC-bus voltage and the control factor of the PWM corresponds to the height of the output voltage. If the DC-bus voltage changes due to mains fluctuations or load changes, the control factor of the PWM must be adapted if the output voltage is to remain constant. This correction is carried out in the control software by measuring the DC-bus voltage. In order that no response takes place to faults in the DC-bus voltage measurement, a filter can be activated for the measured signal via this parameter.</p> <ul style="list-style-type: none"> <li>• The filter time constant is selected so that a quick correction can be carried out even under bad EMC conditions.</li> <li>• A disadvantage of this filter is that the responses to real flickers on the DC-bus voltage are too slow. In positioning tasks, this may cause an extreme increase of the following error.</li> <li>• Under good EMC conditions, this filter is not required (Lenze setting).</li> <li>• For devices &gt; BF7 the filter is ineffective.</li> </ul>		
Selection list (Lenze setting printed in bold)		
<b>0</b>	<b>Deactivated</b>	
1	enabled	
<input checked="" type="checkbox"/> Read access <input checked="" type="checkbox"/> Write access <input type="checkbox"/> CINH <input type="checkbox"/> PLC STOP <input type="checkbox"/> No transfer		Scaling factor: 1

C00308

Parameter   Name: <b>C00308   Service code</b>	Data type: UNSIGNED_16 Index: 24267 <sub>d</sub> = 5ECB <sub>h</sub>
<b>This code is for device-internal use only and must not be written to by the user!</b>	

C00309

Parameter   Name: <b>C00309   Service code</b>	Data type: UNSIGNED_32 Index: 24266 <sub>d</sub> = 5ECA <sub>h</sub>
<b>This code is for device-internal use only and must not be written to by the user!</b>	

C00310

Parameter   Name: <b>C00310   Service code</b>	Data type: UNSIGNED_8 Index: 24265 <sub>d</sub> = 5EC9 <sub>h</sub>
<b>This code is for device-internal use only and must not be written to by the user!</b>	

C00311

Parameter   Name: <b>C00311   CAN TPDO1 mask byte x</b>	Data type: BITFIELD_8 Index: 24264 <sub>d</sub> = 5EC8 <sub>h</sub>	
For each byte of the TPDO1 a mask can be parameterised in the corresponding subcode. <ul style="list-style-type: none"> <li>• In case of an event-controlled PDO transmission, only the masked bits will be considered for event control.</li> <li>• Mask "0x0" means that no bit of the corresponding byte actuates the transmission.</li> <li>• Mask "0xff" means that every bit of the corresponding byte can actuate the transmission.</li> </ul> <p style="text-align: right;"><a href="#">▶ "CAN on board" system bus</a></p>		
<b>Setting range</b>		
0x00	0xFF	
<b>Value is bit-coded:</b>		
Bit 0	Mask bit 0	
...	...	
Bit 7	Mask bit 7	
<b>Subcodes</b>	<b>Lenze setting</b>	<b>Info</b>
C00311/1	0x00	Mask for byte 1 ... byte 8 of TPDO1
C00311/...		
C00311/8		
<input checked="" type="checkbox"/> Read access <input checked="" type="checkbox"/> Write access <input type="checkbox"/> CINH <input type="checkbox"/> PLC STOP <input type="checkbox"/> No transfer                   Scaling factor: 1		

## C00312

Parameter   Name:		Data type: BITFIELD_8 Index: 24263 <sub>d</sub> = 5EC7 <sub>h</sub>
<b>C00312   CAN TPDO2 mask byte x</b>		
<p>For each byte of the TPDO2 a mask can be parameterised in the corresponding subcode.</p> <ul style="list-style-type: none"> <li>• In case of an event-controlled PDO transmission, only the masked bits will be considered for event control.</li> <li>• Mask "0x0" means that no bit of the corresponding byte actuates the transmission.</li> <li>• Mask "0xff" means that every bit of the corresponding byte can actuate the transmission.</li> </ul> <p style="text-align: right;">▶ <a href="#">"CAN on board" system bus</a></p>		
Setting range		
0x00		0xFF
Value is bit-coded:		
Bit 0	Mask bit 0	
...	...	
Bit 7	Mask bit 7	
Subcodes	Lenze setting	Info
C00312/1	0x00	Mask for byte 1 ... byte 8 of TPDO2
C00312/...		
C00312/8		
<input checked="" type="checkbox"/> Read access <input checked="" type="checkbox"/> Write access <input type="checkbox"/> CINH <input type="checkbox"/> PLC STOP <input type="checkbox"/> No transfer   Scaling factor: 1		

## C00313

Parameter   Name:		Data type: BITFIELD_8 Index: 24262 <sub>d</sub> = 5EC6 <sub>h</sub>
<b>C00313   CAN TPDO3 mask byte x</b>		
<p>For each byte of the TPDO3 a mask can be parameterised in the corresponding subcode.</p> <ul style="list-style-type: none"> <li>• In case of an event-controlled PDO transmission, only the masked bits will be considered for event control.</li> <li>• Mask "0x0" means that no bit of the corresponding byte actuates the transmission.</li> <li>• Mask "0xff" means that every bit of the corresponding byte can actuate the transmission.</li> </ul> <p style="text-align: right;">▶ <a href="#">"CAN on board" system bus</a></p>		
Setting range		
0x00		0xFF
Value is bit-coded:		
Bit 0	Mask bit 0	
...	...	
Bit 7	Mask bit 7	
Subcodes	Lenze setting	Info
C00313/1	0x00	Mask for byte 1 ... byte 8 of TPDO3
C00313/...		
C00313/8		
<input checked="" type="checkbox"/> Read access <input checked="" type="checkbox"/> Write access <input type="checkbox"/> CINH <input type="checkbox"/> PLC STOP <input type="checkbox"/> No transfer   Scaling factor: 1		



## C00314

Parameter   Name:		Data type: BITFIELD_8 Index: 24261 <sub>d</sub> = 5EC5 <sub>h</sub>
<b>C00314   CAN TPDO4 mask byte x</b>		
<p>For each byte of the TPDO4 a mask can be parameterised in the corresponding subcode.</p> <ul style="list-style-type: none"> <li>• In case of an event-controlled PDO transmission, only the masked bits will be considered for event control.</li> <li>• Mask "0x0" means that no bit of the corresponding byte actuates the transmission.</li> <li>• Mask "0xff" means that every bit of the corresponding byte can actuate the transmission.</li> </ul> <p style="text-align: right;">▶ <a href="#">"CAN on board" system bus</a></p>		
Setting range		
0x00		0xFF
Value is bit-coded:		
Bit 0	Mask bit 0	
...	...	
Bit 7	Mask bit 7	
Subcodes	Lenze setting	Info
C00314/1	0x00	Mask for byte 1 ... byte 8 of TPDO4
C00314/...		
C00314/8		
<input checked="" type="checkbox"/> Read access <input checked="" type="checkbox"/> Write access <input type="checkbox"/> CINH <input type="checkbox"/> PLC STOP <input type="checkbox"/> No transfer   Scaling factor: 1		

## C00320

Parameter   Name:		Data type: BITFIELD_32 Index: 24255 <sub>d</sub> = 5EBF <sub>h</sub>
<b>C00320   CAN TPDOx identifier</b>		
<p>Identifier for TPDO1 ... TPDO4</p> <ul style="list-style-type: none"> <li>• If bit 31 is set (0x8nnnnnnn), the TPDO is deactivated.</li> <li>• The basic setting is according to the "Predefined Connection Set".</li> <li>• Mapping of the CANopen objects <a href="#">I-1800/1</a> ... <a href="#">I-1803/1</a> (see DS301 V4.02).</li> </ul> <p style="text-align: right;">▶ <a href="#">"CAN on board" system bus</a></p>		
Setting range		
0x00000000		0xFFFFFFFF
Value is bit-coded:		
Bit 0	COB-ID bit 0	
...	...	
Bit 31	PDO invalid	
Subcodes	Lenze setting	Info
C00320/1	0x00000181	TPDO1 identifier • After a node address change and CAN reset node, the value 0x180 + node address will be set by default.
C00320/2	0x00000281	TPDO2 identifier • After a node address change and CAN reset node, the value 0x280 + node address will be set by default.
C00320/3	0x00000381	TPDO3 identifier • After a node address change and CAN reset node, the value 0x380 + node address will be set by default.
C00320/4	0x00000481	Identifier TPDO4 • After a node address change and CAN reset node, the value 0x480 + node address will be set by default.
<input checked="" type="checkbox"/> Read access <input checked="" type="checkbox"/> Write access <input type="checkbox"/> CINH <input type="checkbox"/> PLC STOP <input type="checkbox"/> No transfer   Scaling factor: 1		

## C00321

Parameter   Name: <b>C00321   CAN RPDOx identifier</b>		Data type: BITFIELD_32 Index: 24254 <sub>d</sub> = 5EBE <sub>h</sub>
Identifier for RPDO1 ... RPDO4 <ul style="list-style-type: none"> <li>• If bit 31 is set (0x8nnnnnnn), the RPDO is deactivated.</li> <li>• The basic setting is according to the "Predefined Connection Set".</li> <li>• Mapping of the CANopen objects <a href="#">I-1400/1</a> ... <a href="#">I-1403/1</a> (see DS301 V4.02).</li> </ul> <p style="text-align: right;">▶ <a href="#">"CAN on board" system bus</a></p>		
Setting range		
0x00000000		0xFFFFFFFF
Value is bit-coded:		Info
Bit 0	COB-ID bit 0	<ul style="list-style-type: none"> <li>• Bit 0 ... 10: COB-ID</li> <li>• Bit 11 ... 30: Reserved</li> <li>• Bit 31: PDO invalid</li> </ul>
...	...	
Bit 31	PDO invalid	
Subcodes	Lenze setting	Info
C00321/1	0x00000201	RPDO1 identifier <ul style="list-style-type: none"> <li>• After a node address change and CAN reset node, the value 0x200 + node address will be set by default.</li> </ul>
C00321/2	0x00000301	RPDO2 identifier <ul style="list-style-type: none"> <li>• After a node address change and CAN reset node, the value 0x300 + node address will be set by default.</li> </ul>
C00321/3	0x00000401	RPDO3 identifier <ul style="list-style-type: none"> <li>• After a node address change and CAN reset node, the value 0x400 + node address will be set by default.</li> </ul>
C00321/4	0x00000501	Identifier RPDO4 <ul style="list-style-type: none"> <li>• After a node address change and CAN reset node, the value 0x500 + node address will be set by default.</li> </ul>
<input checked="" type="checkbox"/> Read access <input checked="" type="checkbox"/> Write access <input type="checkbox"/> CINH <input type="checkbox"/> PLC STOP <input type="checkbox"/> No transfer		Scaling factor: 1

## C00322

Parameter   Name: <b>C00322   CAN TPDOx Tx mode</b>		Data type: UNSIGNED_8 Index: 24253 <sub>d</sub> = 5EBD <sub>h</sub>
TPDO transmission type according to DS301 V4.02 <ul style="list-style-type: none"> <li>• Types 0 (acyclic sync), 1-240 (cyclic sync), 254 (event-controlled manufacturer-specific), 255 (event-controlled device-profile-specific) are supported.</li> <li>• The basic PDO setting is "254" (event-controlled).</li> <li>• Illustration of the CANopen objects <a href="#">I-1800/2</a> ... <a href="#">I-1803/2</a> (see DS301 V4.02).</li> </ul> <p style="text-align: right;">▶ <a href="#">"CAN on board" system bus</a></p>		
Setting range (min. value   unit   max. value)		
0		255
Subcodes	Lenze setting	Info
C00322/1	254	Transmission mode for TPDO1 ... TPDO4
C00322/...		
C00322/4		
<input checked="" type="checkbox"/> Read access <input checked="" type="checkbox"/> Write access <input type="checkbox"/> CINH <input type="checkbox"/> PLC STOP <input type="checkbox"/> No transfer		Scaling factor: 1

## C00323

Parameter   Name: C00323   CAN RPDOx Rx mode		Data type: UNSIGNED_8 Index: 24252 <sub>d</sub> = 5EBC <sub>h</sub>
RPDO transmission type according to DS301 V4.02 <ul style="list-style-type: none"> <li>For the RPDO, it serves as monitoring setting in the case of sync-controlled PDOs.</li> <li>Types 0 (acyclic sync), 1-240 (cyclic sync), 254 (event-controlled manufacturer-specific), 255 (event-controlled device-profile-specific) are supported.</li> <li>The basic PDO setting is "254" (event-controlled).</li> <li>Illustration of the CANopen objects <a href="#">I-1400/2</a> ... <a href="#">I-1403/2</a> (see DS301 V4.02).</li> </ul> <p style="text-align: right;">▶ <a href="#">"CAN on board" system bus</a></p>		
Setting range (min. value   unit   max. value)		
0		255
Subcodes	Lenze setting	Info
C00323/1	254	Transmission mode for RPDO1 ... RPDO4
C00323/...		
C00323/4		
<input checked="" type="checkbox"/> Read access <input checked="" type="checkbox"/> Write access <input type="checkbox"/> CINH <input type="checkbox"/> PLC STOP <input type="checkbox"/> No transfer             Scaling factor: 1		

## C00324

Parameter   Name: C00324   CAN TPDOx delay time		Data type: UNSIGNED_16 Index: 24251 <sub>d</sub> = 5EBB <sub>h</sub>
TPDO inhibit time according to DS301 V4.02 <ul style="list-style-type: none"> <li>Minimum time between the transmission of two identical TPDOs.</li> <li>The time is entered in 1/10 ms and automatically rounded to full milliseconds by the code.</li> <li>Mapping of the CANopen objects <a href="#">I-1800/3</a> ... <a href="#">I-1803/3</a> (see DS301 V4.02).</li> </ul> <p style="text-align: right;">▶ <a href="#">"CAN on board" system bus</a></p>		
Setting range (min. value   unit   max. value)		
0	1/10 ms	65535
Subcodes	Lenze setting	Info
C00324/1	0 1/10 ms	Delay time for TPDO1 ... TPDO4
C00324/...		
C00324/4		
<input checked="" type="checkbox"/> Read access <input checked="" type="checkbox"/> Write access <input type="checkbox"/> CINH <input type="checkbox"/> PLC STOP <input type="checkbox"/> No transfer             Scaling factor: 1		

## C00325

Parameter   Name: C00325   Service code		Data type: UNSIGNED_8 Index: 24250 <sub>d</sub> = 5EBA <sub>h</sub>
This code is for device-internal use only and must not be written to by the user!		

## C00326

Parameter   Name: C00326   Service code		Data type: UNSIGNED_8 Index: 24249 <sub>d</sub> = 5EB9 <sub>h</sub>
This code is for device-internal use only and must not be written to by the user!		

## C00327

Parameter   Name: C00327   Service code		Data type: BITFIELD_32 Index: 24248 <sub>d</sub> = 5EB8 <sub>h</sub>
This code is for device-internal use only and must not be written to by the user!		

C00328

Parameter   Name: <b>C00328   Service code</b>	Data type: BITFIELD_32 Index: 24247 <sub>d</sub> = 5EB7 <sub>h</sub>
<b>This code is for device-internal use only and must not be written to by the user!</b>	

C00329

Parameter   Name: <b>C00329   Service code</b>	Data type: BITFIELD_32 Index: 24246 <sub>d</sub> = 5EB6 <sub>h</sub>
<b>This code is for device-internal use only and must not be written to by the user!</b>	

C00330

Parameter   Name: <b>C00330   Service code</b>	Data type: BITFIELD_32 Index: 24245 <sub>d</sub> = 5EB5 <sub>h</sub>
<b>This code is for device-internal use only and must not be written to by the user!</b>	

C00335

Parameter   Name: <b>C00335   Service code</b>	Data type: BITFIELD_32 Index: 24240 <sub>d</sub> = 5EB0 <sub>h</sub>
<b>This code is for device-internal use only and must not be written to by the user!</b>	

C00336

Parameter   Name: <b>C00336   Service code</b>	Data type: BITFIELD_32 Index: 24239 <sub>d</sub> = 5EAF <sub>h</sub>
<b>This code is for device-internal use only and must not be written to by the user!</b>	

C00337

Parameter   Name: <b>C00337   Service code</b>	Data type: BITFIELD_32 Index: 24238 <sub>d</sub> = 5EAE <sub>h</sub>
<b>This code is for device-internal use only and must not be written to by the user!</b>	

C00338

Parameter   Name: <b>C00338   Service code</b>	Data type: BITFIELD_32 Index: 24237 <sub>d</sub> = 5EAD <sub>h</sub>
<b>This code is for device-internal use only and must not be written to by the user!</b>	

C00343

Parameter   Name: <b>C00343   CAN TPDO counter</b>	Data type: UNSIGNED_32 Index: 24232 <sub>d</sub> = 5EA8 <sub>h</sub>
<b>Display range (min. value   unit   max. value)</b>	
0	4294967295
<b>Subcodes</b>	<b>Info</b>
C00343/1	From software version V1.5
C00343/...	Counter for TPDO1 ... TPDO4
C00343/4	▶ <a href="#">"CAN on board" system bus</a>
<input checked="" type="checkbox"/> Read access <input type="checkbox"/> Write access <input type="checkbox"/> CINH <input type="checkbox"/> PLC STOP <input type="checkbox"/> No transfer                   Scaling factor: 1	

**C00344**

Parameter   Name: <b>C00344   CAN RPDO counter</b>		Data type: UNSIGNED_32 Index: 24231 <sub>d</sub> = 5EA7 <sub>h</sub>
<b>Display range (min. value   unit   max. value)</b>		
0		4294967295
<b>Subcodes</b>		<b>Info</b>
C00344/1		From software version V1.5
C00344/...		Counter for RPDO1 ... RPDO4
C00344/4		▶ <a href="#">"CAN on board" system bus</a>
<input checked="" type="checkbox"/> Read access <input type="checkbox"/> Write access <input type="checkbox"/> CINH <input type="checkbox"/> PLC STOP <input type="checkbox"/> No transfer		Scaling factor: 1

**C00345**

Parameter   Name: <b>C00345   CAN error</b>		Data type: UNSIGNED_8 Index: 24230 <sub>d</sub> = 5EA6 <sub>h</sub>
▶ <a href="#">"CAN on board" system bus</a>		
<b>Selection list (read only)</b>		
0	No error	
1	Guard Event	
2	Warning	
3	Bus off	
4	Sync telegram error	
6	CAN controller overflow	
<input checked="" type="checkbox"/> Read access <input type="checkbox"/> Write access <input type="checkbox"/> CINH <input type="checkbox"/> PLC STOP <input type="checkbox"/> No transfer		Scaling factor: 1

**C00346**

Parameter   Name: <b>C00346   CAN heartbeat activity</b>		Data type: BITFIELD_32 Index: 24229 <sub>d</sub> = 5EA5 <sub>h</sub>
▶ <a href="#">"CAN on board" system bus: heartbeat protocol</a>		
<b>Display area</b>		
0x00000000		0xFFFFFFFF
<b>Value is bit-coded:</b>		
Bit 0	Heartbeat node 1	
...	...	
Bit 31	Heartbeat node 32	
<input checked="" type="checkbox"/> Read access <input type="checkbox"/> Write access <input type="checkbox"/> CINH <input type="checkbox"/> PLC STOP <input type="checkbox"/> No transfer		Scaling factor: 1

## C00347

Parameter   Name: C00347   CAN heartbeat status		Data type: UNSIGNED_8 Index: 24228 <sub>d</sub> = 5EA4 <sub>h</sub>
▶ <a href="#">"CAN on board" system bus: heartbeat protocol</a>		
Selection list (read only)		
0	Unknown	
4	Stopped	
5	Operational	
127	Pre-Operational	
Subcodes		Info
C00347/1		Status node 1 ... 32
C00347/...		
C00347/32		
<input checked="" type="checkbox"/> Read access <input type="checkbox"/> Write access <input type="checkbox"/> CINH <input type="checkbox"/> PLC STOP <input type="checkbox"/> No transfer		Scaling factor: 1

## C00348

Parameter   Name: C00348   CAN status DIP switch		Data type: UNSIGNED_8 Index: 24227 <sub>d</sub> = 5EA3 <sub>h</sub>
<ul style="list-style-type: none"> <li>• "1" means that the CAN DIP switch has been identified after mains switching and a valid baud rate and node address have been set.</li> <li>• "0" means that no CAN DIP switch or no valid setting has been identified or the setting has been overwritten by writing to code <a href="#">C00350</a> or <a href="#">C00351</a>.</li> </ul>		
▶ <a href="#">"CAN on board" system bus</a>		
Selection list (read only)		Info
0	Setting not accepted	
1	Setting accepted	
<input checked="" type="checkbox"/> Read access <input type="checkbox"/> Write access <input type="checkbox"/> CINH <input type="checkbox"/> PLC STOP <input type="checkbox"/> No transfer		Scaling factor: 1

## C00349

Parameter   Name: C00349   CAN setting - DIP switch		Data type: UNSIGNED_8 Index: 24226 <sub>d</sub> = 5EA2 <sub>h</sub>
Setting of the CAN DIP switch at the last mains connection		
▶ <a href="#">"CAN on board" system bus</a>		
Display range (min. value   unit   max. value)		
0		255
Subcodes		Info
C00349/1		Node address
C00349/2		Baud rate: 0: 500 kbps 1: 250 kbps 2: 125 kbps 3: 50 kbps 4: 1 Mbps 5: 20 kbps 6: 10 kbit/s 14: 800 kbps 255: Automatic detection
<input checked="" type="checkbox"/> Read access <input type="checkbox"/> Write access <input type="checkbox"/> CINH <input type="checkbox"/> PLC STOP <input type="checkbox"/> No transfer		Scaling factor: 1

## C00350

Parameter   Name: <b>C00350   CAN node address</b>		Data type: UNSIGNED_8 Index: 24225 <sub>d</sub> = 5EA1 <sub>h</sub>
<ul style="list-style-type: none"> <li>• A change in the node address will not be effective until a CAN Reset Node is performed.</li> <li>• The basic server channel RX/TX is automatically provided by the node address (<a href="#">C00372</a> and <a href="#">C00373</a>; subcode 1).</li> <li>• Overwriting the value deactivates a possibly existing node address selection entered by means of hardware. ▶ <a href="#">"CAN on board" system bus</a></li> </ul>		
<b>Setting range</b> (min. value   unit   max. value)		<b>Lenze setting</b>
1		127 <b>1</b>
<input checked="" type="checkbox"/> Read access <input checked="" type="checkbox"/> Write access <input type="checkbox"/> CINH <input type="checkbox"/> PLC STOP <input type="checkbox"/> No transfer		Scaling factor: 1

## C00351

Parameter   Name: <b>C00351   CAN baud rate</b>		Data type: UNSIGNED_8 Index: 24224 <sub>d</sub> = 5EA0 <sub>h</sub>
<ul style="list-style-type: none"> <li>• A change in the baud rate will not be effective until a CAN Reset Node is performed.</li> <li>• Overwriting the value deactivates a possibly existing node address selection entered by means of hardware. ▶ <a href="#">"CAN on board" system bus</a></li> </ul>		
<b>Selection list</b> (Lenze setting printed in bold)		
<b>0</b>	<b>500 kbps</b>	
1	250 kbps	
2	125 kbps	
3	50 kbps	
4	1 Mbps	
5	20 kbps	
6	10 kbps	
8	Reserved	
9	Reserved	
10	Reserved	
11	Reserved	
12	Reserved	
13	Reserved	
14	800 kbps	
15	Reserved	
255	Automatic recognition	
<input checked="" type="checkbox"/> Read access <input checked="" type="checkbox"/> Write access <input type="checkbox"/> CINH <input type="checkbox"/> PLC STOP <input type="checkbox"/> No transfer		Scaling factor: 1

## C00352

Parameter   Name: <b>C00352   CAN slave/master</b>		Data type: UNSIGNED_8 Index: 24223 <sub>d</sub> = 5E9F <sub>h</sub>
<p>The drive starts as CAN master after mains switching if a value of "1" has been entered and saved here. ▶ <a href="#">"CAN on board" system bus</a></p>		
<b>Selection list</b> (Lenze setting printed in bold)		
<b>0</b>	<b>slave</b>	
1	master	
<input checked="" type="checkbox"/> Read access <input checked="" type="checkbox"/> Write access <input type="checkbox"/> CINH <input type="checkbox"/> PLC STOP <input type="checkbox"/> No transfer		Scaling factor: 1

## C00356

Parameter   Name: <b>C00356   CAN TPDOx cycle time</b>		Data type: UNSIGNED_16 Index: 24219 <sub>d</sub> = 5E9B <sub>h</sub>
TPDO event time according to DS301 V4.02 <ul style="list-style-type: none"> <li>• If a different value than "0" is entered, the TPDO is transmitted without further consideration of the transport type after the time set has elapsed.</li> <li>• Mapping of the CANopen objects <a href="#">I-1800/5</a> ... <a href="#">I-1803/5</a> (see DS301 V4.02).</li> </ul>		
<a href="#">▶ "CAN on board" system bus</a>		
<b>Setting range (min. value   unit   max. value)</b>		
0	ms	65535
<b>Subcodes</b>	<b>Lenze setting</b>	<b>Info</b>
C00356/1	0 ms	Cycle time for TPDO1 ... TPDO4
C00356/...		
C00356/4		
<input checked="" type="checkbox"/> Read access <input checked="" type="checkbox"/> Write access <input type="checkbox"/> CINH <input type="checkbox"/> PLC STOP <input type="checkbox"/> No transfer           Scaling factor: 1		

## C00357

Parameter   Name: <b>C00357   CAN RPDOx monitoring time</b>		Data type: UNSIGNED_16 Index: 24218 <sub>d</sub> = 5E9A <sub>h</sub>
Mapping of the RPDO event time (see DS301 V4.02) <ul style="list-style-type: none"> <li>• If a value unequal to "0" is entered, the RPDO is not expected before the set time has expired.</li> <li>• If the RPDO is not received within this time, a parameterisable error message can be activated.</li> </ul>		
<a href="#">▶ "CAN on board" system bus</a>		
<b>Setting range (min. value   unit   max. value)</b>		
0	ms	65535
<b>Subcodes</b>	<b>Lenze setting</b>	<b>Info</b>
C00357/1	3000 ms	Monitoring time for RPDO1 ... RPDO4
C00357/...		
C00357/4		
<input checked="" type="checkbox"/> Read access <input checked="" type="checkbox"/> Write access <input type="checkbox"/> CINH <input type="checkbox"/> PLC STOP <input type="checkbox"/> No transfer           Scaling factor: 1		

## C00359

Parameter   Name: <b>C00359   CAN status</b>		Data type: UNSIGNED_8 Index: 24216 <sub>d</sub> = 5E98 <sub>h</sub>
<a href="#">▶ "CAN on board" system bus</a>		
<b>Selection list (read only)</b>		
0	Operational	
1	Pre-Operational	
4	Boot-up	
5	Stopped	
7	Reset	
8	Initialisation	
9	Unknown	
10	Baud rate autom. detected	
<input checked="" type="checkbox"/> Read access <input type="checkbox"/> Write access <input type="checkbox"/> CINH <input type="checkbox"/> PLC STOP <input type="checkbox"/> No transfer           Scaling factor: 1		



## C00360

Parameter   Name: <b>C00360   CAN telegram and error counter</b>		Data type: UNSIGNED_16 Index: 24215 <sub>d</sub> = 5E97 <sub>h</sub>
<ul style="list-style-type: none"> <li>• After mains connection, all counters start with "0".</li> <li>• After the maximum value has been reached, counting restarts with "0".</li> </ul> <p style="text-align: right;"><a href="#">▶ "CAN on board" system bus</a></p>		
Display range (min. value   unit   max. value)		
0		65535
Subcodes	Info	
C00360/1	Stuffing bit error counter • More than five identical bits have been detected.	
C00360/2	Format error counter • CAN frame has not been observed.	
C00360/3	Acknowledge error counter • No node has confirmed the telegram.	
C00360/4	Bit1 error counter • "1" should be sent after bus arbitration, but "0" was read.	
C00360/5	Bit0 error counter • "0" should be sent after bus arbitration, but "1" was read.	
C00360/6	CRC error counter • Checksum check has indicated an error.	
C00360/7	Tx telegram counter • Telegrams received without errors.	
C00360/8	Rx telegram counter • Telegrams sent without errors.	
<input checked="" type="checkbox"/> Read access <input type="checkbox"/> Write access <input type="checkbox"/> CINH <input type="checkbox"/> PLC STOP <input type="checkbox"/> No transfer		Scaling factor: 1

## C00361

Parameter   Name: <b>C00361   CAN bus load</b>		Data type: UNSIGNED_32 Index: 24214 <sub>d</sub> = 5E96 <sub>h</sub>
<p>The display of the node peak load (subcodes 4 ... 6) is reset by repeated mains switching or via the "Reset node" device command (<a href="#">C00002</a>).</p> <p style="text-align: right;"><a href="#">▶ "CAN on board" system bus</a></p>		
Display range (min. value   unit   max. value)		
0	%	100
Subcodes	Info	
C00361/1	Current node load in Tx direction	
C00361/2	Current node load in Rx direction	
C00361/3	Current node load by faulty telegrams	
C00361/4	Node peak load in Tx direction	
C00361/5	Node peak load in Rx direction	
C00361/6	Node peak load by faulty telegrams	
<input checked="" type="checkbox"/> Read access <input type="checkbox"/> Write access <input type="checkbox"/> CINH <input type="checkbox"/> PLC STOP <input type="checkbox"/> No transfer		Scaling factor: 1

## C00367

Parameter   Name: <b>C00367   CAN SYNC Rx identifier</b>		Data type: UNSIGNED_32 Index: 24208 <sub>d</sub> = 5E90 <sub>h</sub>
Identifier by means of which the sync slave is to receive sync telegrams. <ul style="list-style-type: none"> <li>• Mapping of the CANopen object <a href="#">I-1005</a> (see DS301 V4.02). <p style="text-align: right;">▶ <a href="#">"CAN on board" system bus: sync telegram</a></p> </li> </ul>		
<b>Setting range (min. value   unit   max. value)</b>		<b>Lenze setting</b>
0		2047 <b>128</b>
<input checked="" type="checkbox"/> Read access <input checked="" type="checkbox"/> Write access <input type="checkbox"/> CINH <input type="checkbox"/> PLC STOP <input type="checkbox"/> No transfer		Scaling factor: 1

## C00368

Parameter   Name: <b>C00368   CAN SYNC Tx identifier</b>		Data type: UNSIGNED_32 Index: 24207 <sub>d</sub> = 5E8F <sub>h</sub>
Identifier by means of which the sync master is to transmit sync telegrams. <ul style="list-style-type: none"> <li>• Mapping of the CANopen object <a href="#">I-1005</a> (see DS301 V4.02). <p style="text-align: right;">▶ <a href="#">"CAN on board" system bus: sync telegram</a></p> </li> </ul>		
<b>Setting range (min. value   unit   max. value)</b>		<b>Lenze setting</b>
0		2047 <b>128</b>
<input checked="" type="checkbox"/> Read access <input checked="" type="checkbox"/> Write access <input type="checkbox"/> CINH <input type="checkbox"/> PLC STOP <input type="checkbox"/> No transfer		Scaling factor: 1

## C00369

Parameter   Name: <b>C00369   CAN sync transmission cycle time</b>		Data type: UNSIGNED_16 Index: 24206 <sub>d</sub> = 5E8E <sub>h</sub>
Cycle during which the sync master is to transmit sync telegrams. <ul style="list-style-type: none"> <li>• If "0 ms" is set (Lenze setting), no sync telegrams are generated.</li> <li>• Mapping of the CANopen object <a href="#">I-1006</a> (see DS301 V4.02). <p style="text-align: right;">▶ <a href="#">"CAN on board" system bus: sync telegram</a></p> </li> </ul>		
<b>Setting range (min. value   unit   max. value)</b>		
0	ms	65535
<b>Subcodes</b>	<b>Lenze setting</b>	<b>Info</b>
C00369/1	0 ms	Transmission cycle time for CAN on board
C00369/2	0 ms	Transmission cycle time for CAN module in MXI1/MXI2
C00369/3	0 ms	-(no meaning)
<input checked="" type="checkbox"/> Read access <input checked="" type="checkbox"/> Write access <input type="checkbox"/> CINH <input type="checkbox"/> PLC STOP <input type="checkbox"/> No transfer		Scaling factor: 1

## C00372

Parameter   Name: C00372   CAN SDO server Rx identifier		Data type: BITFIELD_32 Index: 24203 <sub>d</sub> = 5E8B <sub>h</sub>
Identifier with which the corresponding SDO server can be reached. <ul style="list-style-type: none"> <li>• If bit 31 is set (0x8nnnnnnn), the corresponding SDO server is deactivated.</li> <li>• Mapping of the CANopen objects <a href="#">I-1200/1</a> ... <a href="#">I-1209/1</a> (see DS301 V4.02).</li> </ul> <p style="text-align: right;">▶ <a href="#">"CAN on board" system bus</a></p>		
Setting range		
0x00000000		0xFFFFFFFF
Value is bit-coded:		Info
Bit 0	COB-ID bit 0	<ul style="list-style-type: none"> <li>• Bit 0 ... 10: COB-ID</li> <li>• Bit 11 ... 30: Reserved</li> <li>• Bit 31: SDO invalid</li> </ul>
...	...	
Bit 31	SDO invalid	
Subcodes	Lenze setting	Info
C00372/1	0x00000601	SDO server channel 1 RX <ul style="list-style-type: none"> <li>• Subcode 1 contains the basic SDO channel which can neither be changed nor deactivated, according to DS301 V4.02. Writing to the subcode has no effect.</li> <li>• The value under subcode 1 results from the node address (<a href="#">C00350</a>) + 0x600.</li> </ul>
C00372/2	0x80000000	SDO server channel 2 RX
C00372/3	0x80000000	SDO server channel 3 RX
C00372/4	0x80000000	SDO server channel 4 RX
C00372/5	0x80000000	SDO server channel 5 RX
C00372/6	0x80000000	SDO server channel 6 RX
C00372/7	0x80000000	SDO server channel 7 RX
C00372/8	0x80000000	SDO server channel 8 RX
C00372/9	0x80000000	SDO server channel 9 RX
C00372/10	0x80000000	SDO server channel 10 RX
<input checked="" type="checkbox"/> Read access <input checked="" type="checkbox"/> Write access <input type="checkbox"/> CINH <input type="checkbox"/> PLC STOP <input type="checkbox"/> No transfer		Scaling factor: 1

## C00373

Parameter   Name: <b>C00373   CAN SDO server Tx identifier</b>		Data type: BITFIELD_32 Index: 24202 <sub>d</sub> = 5E8A <sub>h</sub>
Identifier with which the corresponding SDO server can carry out transmissions. <ul style="list-style-type: none"> <li>• If bit 31 is set (0x8nnnnnnn), the corresponding SDO server is deactivated.</li> <li>• Mapping of the CANopen objects <a href="#">I-1200/2</a> ... <a href="#">I-1209/2</a> (see DS301 V4.02).</li> </ul> <p style="text-align: right;">▶ <a href="#">"CAN on board" system bus</a></p>		
Setting range		
0x00000000		0xFFFFFFFF
Value is bit-coded:		Info
Bit 0	COB-ID bit 0	<ul style="list-style-type: none"> <li>• Bit 0 ... 10: COB-ID</li> <li>• Bit 11 ... 30: Reserved</li> <li>• Bit 31: SDO invalid</li> </ul>
...	...	
Bit 31	SDO invalid	
Subcodes	Lenze setting	Info
C00373/1	0x00000581	SDO server channel 1 TX <ul style="list-style-type: none"> <li>• Subcode 1 contains the basic SDO channel which can neither be changed nor deactivated, according to DS301 V4.02. Writing to the subcode has no effect.</li> <li>• The value under subcode 1 results from the node address (<a href="#">C00350</a>) + 0x580.</li> </ul>
C00373/2	0x80000000	SDO server channel 2 TX
C00373/3	0x80000000	SDO server channel 3 TX
C00373/4	0x80000000	SDO server channel 4 TX
C00373/5	0x80000000	SDO server channel 5 TX
C00373/6	0x80000000	SDO server channel 6 TX
C00373/7	0x80000000	SDO server channel 7 TX
C00373/8	0x80000000	SDO server channel 8 TX
C00373/9	0x80000000	SDO server channel 9 TX
C00373/10	0x80000000	SDO server channel 10 TX
<input checked="" type="checkbox"/> Read access <input checked="" type="checkbox"/> Write access <input type="checkbox"/> CINH <input type="checkbox"/> PLC STOP <input type="checkbox"/> No transfer		Scaling factor: 1

## C00374

Parameter   Name:		Data type: UNSIGNED_8 Index: 24201 <sub>d</sub> = 5E89 <sub>h</sub>
<b>C00374   CAN SDO client node address</b>		
Node address of the client assigned to this server (see DS301 V4.02). <a href="#">▶ "CAN on board" system bus</a>		
Setting range (min. value   unit   max. value)		
1		127
Subcodes	Lenze setting	Info
C00374/1	1	SDO server channel 1 remote client node address • Subcode 1 contains the basic SDO channel which, according to DS301 V4.02, does not feature this entry. Writing to the subcode has no effect. • The value of subindex 1 is 0.
C00374/2	1	SDO server channel 2 remote client node address
C00374/3	1	SDO server channel 3 remote client node address
C00374/4	1	SDO server channel 4 remote client node address
C00374/5	1	SDO server channel 5 remote client node address
C00374/6	1	SDO server channel 6 remote client node address
C00374/7	1	SDO server channel 7 remote client node address
C00374/8	1	SDO server channel 8 remote client node address
C00374/9	1	SDO server channel 9 remote client node address
C00374/10	1	SDO server channel 10 remote client node address
<input checked="" type="checkbox"/> Read access <input checked="" type="checkbox"/> Write access <input type="checkbox"/> CINH <input type="checkbox"/> PLC STOP <input type="checkbox"/> No transfer		Scaling factor: 1

## C00375

Parameter   Name:		Data type: BITFIELD_32 Index: 24200 <sub>d</sub> = 5E88 <sub>h</sub>
<b>C00375   CAN SDO client Rx identifier</b>		
Identifier with which the corresponding SDO client can be reached. • If bit 31 is set (0x8nnnnnnn), the corresponding SDO client channel is deactivated (see DS301 V4.02). • The client channels need not be parameterised right now. Their functionality will only be required when using the gateway services. <a href="#">▶ "CAN on board" system bus</a>		
Setting range		
0x00000000		0xFFFFFFFF
Value is bit-coded:		Info
Bit 0	COB-ID bit 0	• Bit 0 ... 10: COB-ID • Bit 11 ... 30: Reserved • Bit 31: SDO invalid
...	...	
Bit 31	SDO invalid	
Subcodes	Lenze setting	Info
C00375/1	0x80000000	SDO client channel 1 RX ... 10 RX
C00375/...		
C00375/10		
<input checked="" type="checkbox"/> Read access <input checked="" type="checkbox"/> Write access <input type="checkbox"/> CINH <input type="checkbox"/> PLC STOP <input type="checkbox"/> No transfer		Scaling factor: 1

## C00376

Parameter   Name:		Data type: BITFIELD_32 Index: 24199 <sub>d</sub> = 5E87 <sub>h</sub>	
<b>C00376   CAN SDO client Tx identifier</b>			
Identifier with which the corresponding SDO client can carry out transmissions. <ul style="list-style-type: none"> <li>• If bit 31 is set (0x8nnnnnnn), the corresponding SDO client channel is deactivated (see DS301 V4.02).</li> <li>• The client channels need not be parameterised right now. Their functionality will only be required when using the gateway services.</li> </ul> <p style="text-align: right;">▶ <a href="#">"CAN on board" system bus</a></p>			
Setting range			
0x00000000		0xFFFFFFFF	
Value is bit-coded:		Info	
Bit 0	COB-ID bit 0	<ul style="list-style-type: none"> <li>• Bit 0 ... 10: COB-ID</li> <li>• Bit 11 ... 30: Reserved</li> <li>• Bit 31: SDO invalid</li> </ul>	
...	...		
Bit 31	SDO invalid		
Subcodes	Lenze setting	Info	
C00376/1	0x80000000	SDO client channel 1 TX ... 10 TX	
C00376/...			
C00376/10			
<input checked="" type="checkbox"/> Read access <input checked="" type="checkbox"/> Write access <input type="checkbox"/> CINH <input type="checkbox"/> PLC STOP <input type="checkbox"/> No transfer   Scaling factor: 1			

## C00377

Parameter   Name:		Data type: UNSIGNED_8 Index: 24198 <sub>d</sub> = 5E86 <sub>h</sub>	
<b>C00377   CAN SDO server node address</b>			
Node address of the server with which this client communicates via the client channel selected. <ul style="list-style-type: none"> <li>• An activation of the client functionality is not required.</li> <li>• The entry is required so that the CAN-SDO client channel can be activated (see DS301 V4.02).</li> </ul> <p style="text-align: right;">▶ <a href="#">"CAN on board" system bus</a></p>			
Setting range (min. value   unit   max. value)			
1		127	
Subcodes	Lenze setting	Info	
C00377/1	1	Remote server node address for SDO client channel 1 ...	
C00377/...		10	
C00377/10			
<input checked="" type="checkbox"/> Read access <input checked="" type="checkbox"/> Write access <input type="checkbox"/> CINH <input type="checkbox"/> PLC STOP <input type="checkbox"/> No transfer   Scaling factor: 1			

## C00378

Parameter   Name:		Data type: UNSIGNED_16 Index: 24197 <sub>d</sub> = 5E85 <sub>h</sub>	
<b>C00378   CAN delay boot-up - Operational</b>			
Time that has to elapse after mains switching before the CAN NMT master places the "Start Remote Node" telegram to the bus. <ul style="list-style-type: none"> <li>• This time is only used if the master bit is activated (<a href="#">C00352</a>) and after mains switching.</li> </ul> <p style="text-align: right;">▶ <a href="#">"CAN on board" system bus</a></p>			
Setting range (min. value   unit   max. value)			Lenze setting
0	ms	65535	3000 ms
<input checked="" type="checkbox"/> Read access <input checked="" type="checkbox"/> Write access <input type="checkbox"/> CINH <input type="checkbox"/> PLC STOP <input type="checkbox"/> No transfer   Scaling factor: 1			

## C00379

Parameter   Name: <b>C00379   Service code</b>	Data type: UNSIGNED_8 Index: 24196 <sub>d</sub> = 5E84 <sub>h</sub>
<b>This code is for device-internal use only and must not be written to by the user!</b>	

## C00381

Parameter   Name: <b>C00381   CAN Heartbeat producer time</b>	Data type: UNSIGNED_16 Index: 24194 <sub>d</sub> = 5E82 <sub>h</sub>
<p>Time interval for the transmission of the heartbeat telegram to the consumer(s).</p> <ul style="list-style-type: none"> <li>• The parameterised time is rounded down to an integer multiple of 5 ms.</li> <li>• The heartbeat telegram is transmitted automatically as soon as a time &gt; 0 ms is set. The monitoring function "Node Guarding" is deactivated in this case.</li> <li>• Mapping of the CANopen object <a href="#">I-1017</a> (see DS301 V4.02). ▶ <a href="#">"CAN on board" system bus: heartbeat protocol</a></li> </ul>	
<b>Setting range (min. value   unit   max. value)</b>	<b>Lenze setting</b>
0   ms   65535	<b>0 ms</b>
<input checked="" type="checkbox"/> Read access <input checked="" type="checkbox"/> Write access <input type="checkbox"/> CINH <input type="checkbox"/> PLC STOP <input type="checkbox"/> No transfer   Scaling factor: 1	

## C00382

Parameter   Name: <b>C00382   CAN Guard Time</b>	Data type: UNSIGNED_16 Index: 24193 <sub>d</sub> = 5E81 <sub>h</sub>
<p>After the set guard time multiplied by the life time factor (<a href="#">C00383</a>), a node guarding telegram must have been received.</p> <ul style="list-style-type: none"> <li>• Mapping of the CANopen object <a href="#">I-100C</a> (see DS301 V4.02). ▶ <a href="#">"CAN on board" system bus: node guarding protocol</a></li> </ul>	
<b>Setting range (min. value   unit   max. value)</b>	<b>Lenze setting</b>
0   ms   65535	<b>0 ms</b>
<input checked="" type="checkbox"/> Read access <input checked="" type="checkbox"/> Write access <input type="checkbox"/> CINH <input type="checkbox"/> PLC STOP <input type="checkbox"/> No transfer   Scaling factor: 1	

## C00383

Parameter   Name: <b>C00383   CAN Life Time Factor</b>	Data type: UNSIGNED_8 Index: 24192 <sub>d</sub> = 5E80 <sub>h</sub>
<p>The life time factor multiplied by the guard time (<a href="#">C00382</a>) results in the time in which a node guarding telegram must have been received.</p> <ul style="list-style-type: none"> <li>• Mapping of the CANopen object <a href="#">I-100D</a> (see DS301 V4.02). ▶ <a href="#">"CAN on board" system bus: node guarding protocol</a></li> </ul>	
<b>Setting range (min. value   unit   max. value)</b>	<b>Lenze setting</b>
0     255	<b>0</b>
<input checked="" type="checkbox"/> Read access <input checked="" type="checkbox"/> Write access <input type="checkbox"/> CINH <input type="checkbox"/> PLC STOP <input type="checkbox"/> No transfer   Scaling factor: 1	

## C00385

Parameter   Name:		Data type: BITFIELD_32 Index: 24190 <sub>d</sub> = 5E7E <sub>h</sub>
<b>C00385   CAN Heartbeat Consumer Time</b>		
<p>The 32 subcodes represent the nodes which are to be monitored via heartbeat.</p> <ul style="list-style-type: none"> <li>Each subcode entry contains the expected "heartbeat" time and the node ID (node address) from which the heartbeat telegram is expected in the form of a bit code.</li> <li>The parameterised time is rounded down to an integer multiple of 5 ms and must have a greater value than the heartbeat producer time of the node to be monitored.</li> <li>The response to a missing heartbeat telegram can be parameterised in <a href="#">C00613</a>.</li> <li>Mapping of the CANopen object <a href="#">I-1016</a> (see DS301 V4.02).</li> </ul> <p style="text-align: right;">▶ <a href="#">"CAN on board" system bus: heartbeat protocol</a></p>		
Setting range		
0x00000000		0xFFFFFFFF
Value is bit-coded:		Info
Bit 0	Heartbeat time bit 0	<ul style="list-style-type: none"> <li>Bit 0 ... 15: Heartbeat time</li> <li>Bit 16 ... 23: Node address</li> <li>Bit 24 ... 31: Reserved</li> </ul>
...	...	
Bit 31	Reserved	
Subcodes	Lenze setting	Info
C00385/1	0x00000000	Monitoring entry 1 ... 32
C00385/...		
C00385/32		
<input checked="" type="checkbox"/> Read access <input checked="" type="checkbox"/> Write access <input type="checkbox"/> CINH <input type="checkbox"/> PLC STOP <input type="checkbox"/> No transfer   Scaling factor: 1		

## C00386

Parameter   Name:		Data type: BITFIELD_32 Index: 24189 <sub>d</sub> = 5E7D <sub>h</sub>
<b>C00386   CAN Node Guarding</b>		
<p>The 32 subcodes represent the nodes to be monitored by the master by means of node guarding.</p> <ul style="list-style-type: none"> <li>Each subcode entry contains the guard time, the lifetime factor and the node ID (node address) from which the heartbeat telegram is expected in the form of a bit code.</li> <li>The response to a missing node guarding response can be parameterised in <a href="#">C00612</a>.</li> </ul> <p style="text-align: right;">▶ <a href="#">"CAN on board" system bus: node guarding protocol</a></p>		
Setting range		
0x00000000		0xFFFFFFFF
Value is bit-coded:		Info
Bit 0	Guard time bit 0	<ul style="list-style-type: none"> <li>Bit 0 ... 15: Guard time</li> <li>Bit 16 ... 23: Node address</li> <li>Bit 24 ... 31: Lifetime factor</li> </ul>
...	...	
Bit 31	Lifetime factor bit 7	
Subcodes	Lenze setting	Info
C00386/1	0x00000000	Monitoring entry 1 ... 32
C00386/...		
C00386/32		
<input checked="" type="checkbox"/> Read access <input checked="" type="checkbox"/> Write access <input type="checkbox"/> CINH <input type="checkbox"/> PLC STOP <input type="checkbox"/> No transfer   Scaling factor: 1		



## C00387

Parameter   Name: <b>C00387   CAN Node Guarding Activity</b>		Data type: BITFIELD_32 Index: 24188 <sub>d</sub> = 5E7C <sub>h</sub>
▶ <a href="#">"CAN on board" system bus: node guarding protocol</a>		
<b>Display area</b>		
0x00000000		0xFFFFFFFF
<b>Value is bit-coded:</b>		
Bit 0	Node guarding of node 1	
...	...	
Bit 31	Node guarding of node 32	
<input checked="" type="checkbox"/> Read access <input type="checkbox"/> Write access <input type="checkbox"/> CINH <input type="checkbox"/> PLC STOP <input type="checkbox"/> No transfer		Scaling factor: 1

## C00388

Parameter   Name: <b>C00388   CAN node guarding status</b>		Data type: UNSIGNED_8 Index: 24187 <sub>d</sub> = 5E7B <sub>h</sub>
▶ <a href="#">"CAN on board" system bus: node guarding protocol</a>		
<b>Selection list (read only)</b>		
0	Unknown	
4	Stopped	
5	Operational	
127	Pre-Operational	
<b>Subcodes</b>		<b>Info</b>
C00388/1		Status node 1 ... 32
C00388/...		
C00388/32		
<input checked="" type="checkbox"/> Read access <input type="checkbox"/> Write access <input type="checkbox"/> CINH <input type="checkbox"/> PLC STOP <input type="checkbox"/> No transfer		Scaling factor: 1

## C00390

Parameter   Name: <b>C00390   CAN Error Register (DS301V402)</b>		Data type: BITFIELD_8 Index: 24185 <sub>d</sub> = 5E79 <sub>h</sub>
Mapping of the CANopen object <a href="#">I-1001</a> (see DS301 V4.02).		
▶ <a href="#">"CAN on board" system bus</a>		
<b>Display area</b>		
0x00		0xFF
<b>Value is bit-coded:</b>		<b>Info</b>
Bit 0	Generic error	Currently only bits 0 and 4 contain the corresponding information.
Bit 1	Current error (not used)	
Bit 2	Voltage error (not used)	
Bit 3	Temperature error (not used)	
Bit 4	Communication error	
Bit 5	Dev. prof. spec. err (not used)	
Bit 6	Reserved	
Bit 7	Manuf. spec. error (not used)	
<input checked="" type="checkbox"/> Read access <input type="checkbox"/> Write access <input type="checkbox"/> CINH <input type="checkbox"/> PLC STOP <input type="checkbox"/> No transfer		Scaling factor: 1

C00391

Parameter   Name: <b>C00391   CAN Emergency Object</b>		Data type: BITFIELD_32 Index: 24184 <sub>d</sub> = 5E78 <sub>h</sub>
Identifier of the emergency telegram <ul style="list-style-type: none"> <li>• If bit 31 of this code is set (0x8nnnnnnn), the generation of emergency telegrams is deactivated.</li> <li>• Mapping of the CANopen object <a href="#">I-1014</a> (see DS301 V4.02).</li> </ul> <p style="text-align: right;">▶ <a href="#">"CAN on board" system bus</a></p>		
Setting range		Lenze setting
0x00000000	0xFFFFFFFF	<b>0x00000081</b> (decimal: 129)
Value is bit-coded: ( <input checked="" type="checkbox"/> = bit set)		Info
Bit 0 <input checked="" type="checkbox"/>	COB-ID bit 0	
Bit 1 <input type="checkbox"/>	COB-ID bit 1	
Bit 2 <input type="checkbox"/>	COB-ID bit 2	
Bit 3 <input type="checkbox"/>	COB-ID bit 3	
Bit 4 <input type="checkbox"/>	COB-ID bit 4	
Bit 5 <input type="checkbox"/>	COB-ID bit 5	
Bit 6 <input type="checkbox"/>	COB-ID bit 6	
Bit 7 <input checked="" type="checkbox"/>	COB-ID bit 7	
Bit 8 <input type="checkbox"/>	COB-ID bit 8	
Bit 9 <input type="checkbox"/>	COB-ID bit 9	
Bit 10 <input type="checkbox"/>	COB-ID bit 10	
Bit 11 <input type="checkbox"/>	Reserved	
Bit 12 <input type="checkbox"/>	Reserved	
Bit 13 <input type="checkbox"/>	Reserved	
Bit 14 <input type="checkbox"/>	Reserved	
Bit 15 <input type="checkbox"/>	Reserved	
Bit 16 <input type="checkbox"/>	Reserved	
Bit 17 <input type="checkbox"/>	Reserved	
Bit 18 <input type="checkbox"/>	Reserved	
Bit 19 <input type="checkbox"/>	Reserved	
Bit 20 <input type="checkbox"/>	Reserved	
Bit 21 <input type="checkbox"/>	Reserved	
Bit 22 <input type="checkbox"/>	Reserved	
Bit 23 <input type="checkbox"/>	Reserved	
Bit 24 <input type="checkbox"/>	Reserved	
Bit 25 <input type="checkbox"/>	Reserved	
Bit 26 <input type="checkbox"/>	Reserved	
Bit 27 <input type="checkbox"/>	Reserved	
Bit 28 <input type="checkbox"/>	Reserved	
Bit 29 <input type="checkbox"/>	Reserved	
Bit 30 <input type="checkbox"/>	Reserved	
Bit 31 <input type="checkbox"/>	Emergency inactive/active	
<input checked="" type="checkbox"/> Read access <input checked="" type="checkbox"/> Write access <input type="checkbox"/> CINH <input type="checkbox"/> PLC STOP <input type="checkbox"/> No transfer		Scaling factor: 1

## C00392

Parameter   Name: <b>C00392   CAN emergency delay time</b>		Data type: UNSIGNED_16 Index: 24183 <sub>d</sub> = 5E77 <sub>h</sub>
Minimum time that has to elapse between two successive emergency telegrams. <ul style="list-style-type: none"> <li>• If "0" is set, checking of the inhibit time is deactivated.</li> <li>• The time is entered in 1/10 ms. The code automatically rounds the entries down to the preceding full millisecond.</li> <li>• Mapping of the CANopen object <a href="#">I-1015</a> (see DS301 V4.02).</li> </ul> <p style="text-align: right;">▶ <a href="#">"CAN on board" system bus</a></p>		
<b>Setting range</b> (min. value   unit   max. value)		<b>Lenze setting</b>
0		65535 0
<input checked="" type="checkbox"/> Read access <input checked="" type="checkbox"/> Write access <input type="checkbox"/> CINH <input type="checkbox"/> PLC STOP <input type="checkbox"/> No transfer		Scaling factor: 1

## C00393

Parameter   Name: <b>C00393   CAN result - bus scan</b>		Data type: UNSIGNED_8 Index: 24182 <sub>d</sub> = 5E76 <sub>h</sub>
Result of CAN bus scanning (see controller commands under <a href="#">C00002</a> ). <ul style="list-style-type: none"> <li>• Subcode number 1 ... 128 corresponds to CAN node address 1 ... 128.</li> </ul> <p style="text-align: right;">▶ <a href="#">"CAN on board" system bus</a></p>		
<b>Display range</b> (min. value   unit   max. value)		
0		1
<b>Subcodes</b>		<b>Info</b>
C00393/1		Result of CAN bus scanning for CAN node address 1 ... 128 <ul style="list-style-type: none"> <li>• The value "1" means that a device with the corresponding node address has been found.</li> </ul>
C00393/...		
C00393/128		
<input checked="" type="checkbox"/> Read access <input type="checkbox"/> Write access <input type="checkbox"/> CINH <input type="checkbox"/> PLC STOP <input type="checkbox"/> No transfer		Scaling factor: 1

## C00394

Parameter   Name: <b>C00394   CAN predefined error field (DS301V402)</b>		Data type: UNSIGNED_32 Index: 24181 <sub>d</sub> = 5E75 <sub>h</sub>
<p style="text-align: right;">▶ <a href="#">"CAN on board" system bus</a></p>		
<b>Display range</b> (min. value   unit   max. value)		
0		4294967295
<b>Subcodes</b>		<b>Info</b>
C00394/1		
C00394/...		
C00394/10		
<input checked="" type="checkbox"/> Read access <input type="checkbox"/> Write access <input type="checkbox"/> CINH <input type="checkbox"/> PLC STOP <input type="checkbox"/> No transfer		Scaling factor: 1

## C00395

Parameter   Name: <b>C00395   Service code</b>		Data type: UNSIGNED_32 Index: 24180 <sub>d</sub> = 5E74 <sub>h</sub>
<b>This code is for device-internal use only and must not be written to by the user!</b>		

## C00396

Parameter   Name: <b>C00396   Service code</b>		Data type: UNSIGNED_32 Index: 24179 <sub>d</sub> = 5E73 <sub>h</sub>
<b>This code is for device-internal use only and must not be written to by the user!</b>		

## C00397

Parameter   Name: <b>C00397   Service code</b>	Data type: UNSIGNED_32 Index: 24177 <sub>d</sub> = 5E72 <sub>h</sub>
<b>This code is for device-internal use only and must not be written to by the user!</b>	

## C00398

Parameter   Name: <b>C00398   Test mode motor control</b>	Data type: UNSIGNED_32 Index: 24177 <sub>d</sub> = 5E71 <sub>h</sub>
<p><b>⚠ Danger!</b>  <b>When the test mode is activated, the parameterisable error response "Quick stop by trouble" has no effect!</b>          If the test mode is active and a monitoring function responds with this error response, no quick stop is executed but the motor continues to rotate with the frequency set for the test mode!</p>	
Selection list (Lenze setting printed in bold)	Info
<b>0</b> Test mode deactivated	
1 U rotation test mode	
2 I rotation test mode	
3 Current controller optimisation mode	After controller enable, the motor is supplied with current as long as the controller is enabled.
4 Current controller optimisation mode impulse	<a href="#">From software version V7.0</a> The motor is supplied with voltage for 50 ms after controller enable. Due to this time limit, the load of the machine is reduced. Afterwards, the controller is inhibited automatically.
<input checked="" type="checkbox"/> Read access <input checked="" type="checkbox"/> Write access <input checked="" type="checkbox"/> CINH <input type="checkbox"/> PLC STOP <input checked="" type="checkbox"/> No transfer   Scaling factor: 1	

## C00399

Parameter   Name: <b>C00399   Settings for test mode</b>	Data type: INTEGER_32 Index: 24176 <sub>d</sub> = 5E70 <sub>h</sub>	
Setting range (min. value   unit   max. value)		
-1000.0      Hz/1°      1000.0		
Subcodes	Lenze setting	Info
C00399/1	0.0 Hz/1°	Frequency [Hz] for test mode
C00399/2	0.0 Hz/1°	Start angle [°] for test mode
<input checked="" type="checkbox"/> Read access <input checked="" type="checkbox"/> Write access <input type="checkbox"/> CINH <input type="checkbox"/> PLC STOP <input checked="" type="checkbox"/> No transfer   Scaling factor: 10		

## C00412

Parameter   Name: <b>C00412   Hiperface: Initialisation time</b>	Data type: UNSIGNED_32 Index: 24163 <sub>d</sub> = 5E63 <sub>h</sub>
<p><a href="#">From software version V11.0</a>  <a href="#">▶ Parameterisation of a Hiperface encoder with increased initialisation time</a></p>	
Setting range (min. value   unit   max. value)	Lenze setting
150      ms      2000	<b>650 ms</b>
<input checked="" type="checkbox"/> Read access <input checked="" type="checkbox"/> Write access <input type="checkbox"/> CINH <input type="checkbox"/> PLC STOP <input type="checkbox"/> No transfer   Scaling factor: 1	

## C00413

Parameter   Name: <b>C00413   Hiperface: detected TypeCode</b>		Data type: UNSIGNED_32 Index: 24162 <sub>d</sub> = 5E62 <sub>h</sub>
From software version V4.0 Type code read out of the connected Hiperface encoder <a href="#">▶ Parameterisation of an unknown Hiperface encoder</a>		
<b>Display range (min. value   unit   max. value)</b>		
0		255
<input checked="" type="checkbox"/> Read access <input type="checkbox"/> Write access <input type="checkbox"/> CINH <input type="checkbox"/> PLC STOP <input type="checkbox"/> No transfer		Scaling factor: 1

## C00414

Parameter   Name: <b>C00414   Hiperface: TypeCode</b>		Data type: UNSIGNED_32 Index: 24161 <sub>d</sub> = 5E61 <sub>h</sub>
From software version V4.0 Setting the type code for a Hiperface encoder unknown to the controller <a href="#">▶ Parameterisation of an unknown Hiperface encoder</a>		
<b>Setting range (min. value   unit   max. value)</b>		<b>Lenze setting</b>
0		255 0
<input checked="" type="checkbox"/> Read access <input checked="" type="checkbox"/> Write access <input type="checkbox"/> CINH <input type="checkbox"/> PLC STOP <input type="checkbox"/> No transfer		Scaling factor: 1

## C00415

Parameter   Name: <b>C00415   Hiperface: number of rev.</b>		Data type: UNSIGNED_32 Index: 24160 <sub>d</sub> = 5E60 <sub>h</sub>
From software version V4.0 Number of displayable revolutions for a multi-turn encoder <a href="#">▶ Parameterisation of an unknown Hiperface encoder</a>		
<b>Setting range (min. value   unit   max. value)</b>		<b>Lenze setting</b>
0		16384 0
<input checked="" type="checkbox"/> Read access <input checked="" type="checkbox"/> Write access <input type="checkbox"/> CINH <input type="checkbox"/> PLC STOP <input type="checkbox"/> No transfer		Scaling factor: 1

## C00416

Parameter   Name: <b>C00416   Service code</b>		Data type: UNSIGNED_32 Index: 24159 <sub>d</sub> = 5E5F <sub>h</sub>
<b>This code is for device-internal use only and must not be written to by the user!</b>		

## C00417

Parameter   Name: <b>C00417   Dynamic of resolver evaluation</b>		Data type: UNSIGNED_32 Index: 24158 <sub>d</sub> = 5E5E <sub>h</sub>
From software version V5.0 <a href="#">▶ Adaptation of the resolver evaluation dynamics</a>		
<b>Setting range (min. value   unit   max. value)</b>		<b>Lenze setting</b>
100	%	1000 100 %
<input checked="" type="checkbox"/> Read access <input checked="" type="checkbox"/> Write access <input type="checkbox"/> CINH <input type="checkbox"/> PLC STOP <input type="checkbox"/> No transfer		Scaling factor: 1

## C00418

Parameter   Name: <b>C00418   Activate resolver error compensation</b>		Data type: UNSIGNED_8 Index: 24157 <sub>d</sub> = 5E5D <sub>h</sub>
From software version V7.0		<a href="#">► Resolver error compensation</a>
Selection list (Lenze setting printed in bold)		
0	<b>Deactivated</b>	
1	enabled	
<input checked="" type="checkbox"/> Read access <input checked="" type="checkbox"/> Write access <input type="checkbox"/> CINH <input type="checkbox"/> PLC STOP <input type="checkbox"/> No transfer		Scaling factor: 1

## C00420

Parameter   Name: <b>C00420   Number of encoder increments</b>		Data type: UNSIGNED_16 Index: 24155 <sub>d</sub> = 5E5B <sub>h</sub>
Setting range (min. value   unit   max. value)		Lenze setting
1		16384 <b>512</b>
<input checked="" type="checkbox"/> Read access <input checked="" type="checkbox"/> Write access <input checked="" type="checkbox"/> CINH <input type="checkbox"/> PLC STOP <input type="checkbox"/> No transfer		Scaling factor: 1

## C00421

Parameter   Name: <b>C00421   Encoder voltage</b>		Data type: UNSIGNED_16 Index: 24154 <sub>d</sub> = 5E5A <sub>h</sub>
Setting range (min. value   unit   max. value)		Lenze setting
5.0	V	12.0 <b>5.0 V</b>
<input checked="" type="checkbox"/> Read access <input checked="" type="checkbox"/> Write access <input checked="" type="checkbox"/> CINH <input type="checkbox"/> PLC STOP <input type="checkbox"/> No transfer		Scaling factor: 10

## C00422

Parameter   Name: <b>C00422   Encoder type</b>		Data type: UNSIGNED_16 Index: 24153 <sub>d</sub> = 5E59 <sub>h</sub>
Selection list (Lenze setting printed in bold)		Info
0	<b>Incremental encoder (TTL signal)</b>	
1	Sin/cos encoder	
2	Absolute value encoder (Hiperface)	
3	Absolute value encoder (EnDat)	
4	SSI encoder	From software version V5.0 <a href="#">► Use of an SSI encoder at X8</a>
<input checked="" type="checkbox"/> Read access <input checked="" type="checkbox"/> Write access <input checked="" type="checkbox"/> CINH <input type="checkbox"/> PLC STOP <input type="checkbox"/> No transfer		Scaling factor: 1

## C00423

Parameter   Name: <b>C00423   SSI encoder: Bit rate</b>		Data type: UNSIGNED_32 Index: 24152 <sub>d</sub> = 5E58 <sub>h</sub>
From software version V5.0		<a href="#">► Use of an SSI encoder at X8</a>
Setting range (min. value   unit   max. value)		Lenze setting
150	kbps	1000 <b>400 kbps</b>
<input checked="" type="checkbox"/> Read access <input checked="" type="checkbox"/> Write access <input checked="" type="checkbox"/> CINH <input type="checkbox"/> PLC STOP <input type="checkbox"/> No transfer		Scaling factor: 1

## C00424

Parameter   Name: <b>C00424   SSI encoder: Data word length</b>		Data type: UNSIGNED_32 Index: 24151 <sub>d</sub> = 5E57 <sub>h</sub>	
From software version V5.0			
<a href="#">▶ Use of an SSI encoder at X8</a>			
Setting range (min. value   unit   max. value)		Lenze setting	
1	Bit	31	<b>25 bits</b>
<input checked="" type="checkbox"/> Read access <input checked="" type="checkbox"/> Write access <input checked="" type="checkbox"/> CINH <input type="checkbox"/> PLC STOP <input type="checkbox"/> No transfer		Scaling factor: 1	

## C00427

Parameter   Name: <b>C00427   TTL encoder signal evaluation</b>		Data type: UNSIGNED_16 Index: 24148 <sub>d</sub> = 5E54 <sub>h</sub>	
Selection list (Lenze setting printed in bold)			
<b>0</b>	<b>4x evaluation (A, B)</b>		
1	A:Increments B:Sign		
2	Increments A:pos. B:neg.		
<input checked="" type="checkbox"/> Read access <input checked="" type="checkbox"/> Write access <input checked="" type="checkbox"/> CINH <input type="checkbox"/> PLC STOP <input type="checkbox"/> No transfer		Scaling factor: 1	

## C00435

Parameter   Name: <b>C00435   SSI encoder: partword start position</b>		Data type: UNSIGNED_8 Index: 24140 <sub>d</sub> = 5E4C <sub>h</sub>	
From software version V5.0			
<a href="#">▶ Use of an SSI encoder at X8</a>			
Setting range (min. value   unit   max. value)			
0		30	
Subcodes	Lenze setting	Info	
C00435/1	0	SSI enc.: Partword 1 start	
C00435/2	0	SSI enc.: Partword 2 start	
C00435/3	0	SSI enc.: Partword 3 start	
C00435/4	0	SSI enc.: Partword 4 start	
C00435/5	0	Ssi-enc.: Partword 5 start	
C00435/6	0	SSI enc.: Partword 6 start	
C00435/7	0	SSI enc.: Partword 7 start	
C00435/8	0	Ssi-enc.: Partword 8 start	
<input checked="" type="checkbox"/> Read access <input checked="" type="checkbox"/> Write access <input type="checkbox"/> CINH <input type="checkbox"/> PLC STOP <input type="checkbox"/> No transfer		Scaling factor: 1	

## C00436

Parameter   Name: <b>C00436   SSI encoder: partword length</b>		Data type: UNSIGNED_8 Index: 24139 <sub>d</sub> = 5E4B <sub>h</sub>
From software version V5.0		
<a href="#">▶ Use of an SSI encoder at X8</a>		
Setting range (min. value   unit   max. value)		
0		31
Subcodes	Lenze setting	Info
C00436/1	31	SSI enc.: Partword 1 length
C00436/2	0	SSI enc.: Partword 2 length
C00436/3	0	SSI enc.: Partword 3 length
C00436/4	0	SSI enc.: Partword 4 length
C00436/5	0	SSI enc.: Partword 5 length
C00436/6	0	SSI enc.: Partword 6 length
C00436/7	0	SSI enc.: Partword 7 length
C00436/8	0	SSI enc.: Partword 8 length
<input checked="" type="checkbox"/> Read access <input checked="" type="checkbox"/> Write access <input type="checkbox"/> CINH <input type="checkbox"/> PLC STOP <input type="checkbox"/> No transfer		Scaling factor: 1

## C00437

Parameter   Name: <b>C00437   SSI encoder: partword data coding</b>		Data type: UNSIGNED_8 Index: 24138 <sub>d</sub> = 5E4A <sub>h</sub>
From software version V5.0		
<a href="#">▶ Use of an SSI encoder at X8</a>		
Selection list (Lenze setting printed in bold)		
0	<b>binary coded</b>	
1	<b>gray coded</b>	
Subcodes	Lenze setting	Info
C00437/1	0: binary coded	SSI enc.: Partword 1 coding
C00437/2	0: binary coded	SSI enc.: Partword 2 coding
C00437/3	0: binary coded	SSI enc.: Partword 3 coding
C00437/4	0: binary coded	SSI enc.: Partword 4 coding
C00437/5	0: binary coded	SSI enc.: Partword 5 coding
C00437/6	0: binary coded	SSI enc.: Partword 6 coding
C00437/7	0: binary coded	SSI enc.: Partword 7 coding
C00437/8	0: binary coded	SSI enc.: Partword 8 coding
<input checked="" type="checkbox"/> Read access <input checked="" type="checkbox"/> Write access <input type="checkbox"/> CINH <input type="checkbox"/> PLC STOP <input type="checkbox"/> No transfer		Scaling factor: 1



## C00443

Parameter   Name: C00443   Status: Digital inputs		Data type: UNSIGNED 8 Index: 24132 <sub>d</sub> = 5E44 <sub>h</sub>
<b>Display range (min. value   unit   max. value)</b>		
0		1
Subcodes	Info	
C00443/1	Digital input 1	
C00443/2	Digital input 2	
C00443/3	Digital input 3	
C00443/4	Digital input 4	
C00443/5	Digital input 5	
C00443/6	Digital input 6	
C00443/7	Digital input 7	
C00443/8	Digital input 8	
C00443/9	Controller inhibit (inversion of input X5/RFR)	
C00443/10	Internal signal	
C00443/11	Feedback input of holding brake	
C00443/12	State bus input	
<input checked="" type="checkbox"/> Read access <input type="checkbox"/> Write access <input type="checkbox"/> CINH <input type="checkbox"/> PLC STOP <input type="checkbox"/> No transfer		Scaling factor: 1

## C00444

Parameter   Name: C00444   Status: Digital outputs		Data type: UNSIGNED 8 Index: 24131 <sub>d</sub> = 5E43 <sub>h</sub>
<b>Display range (min. value   unit   max. value)</b>		
0		1
Subcodes	Info	
C00444/1	Digital output 1	
C00444/2	Digital output 2	
C00444/3	Digital output 3	
C00444/4	Digital output 4	
C00444/5	Internal signal	
C00444/6	Internal signal	
C00444/7	Internal signal	
C00444/8	Internal signal	
C00444/9	User LED	
C00444/10	Internal signal	
C00444/11	Internal signal	
C00444/12	Internal signal	
C00444/13	Control output of holding brake	
C00444/14	Internal signal	
C00444/15	Internal signal	
C00444/16	Internal signal	
C00444/17	Internal signal	
C00444/18	State bus output	
<input checked="" type="checkbox"/> Read access <input type="checkbox"/> Write access <input type="checkbox"/> CINH <input type="checkbox"/> PLC STOP <input type="checkbox"/> No transfer		Scaling factor: 1

## C00462

Parameter   Name: <b>C00462   Noise signal activation</b>	Data type: UNSIGNED_8 Index: 24113 <sub>d</sub> = 5E31 <sub>h</sub>
<b>This code is for device-internal use only and must not be written to by the user!</b>	

## C00464

Parameter   Name: <b>C00464   Keypad: Mode</b>	Data type: UNSIGNED_16 Index: 24111 <sub>d</sub> = 5E2F <sub>h</sub>
<p>From software version V5.0</p> <p>Definition of the mode in which the keypad attached is to be activated.</p> <ul style="list-style-type: none"> <li>• If both keypad versions (V1.0 and V2.0) are used, the Lenze setting is to be maintained.</li> <li>• If only the new keypad V2.0 is used, the initialisation time of the keypad can be reduced by changing over to mode 2. Furthermore mode 2 supports greater future keypad files.</li> </ul> <p><b>Note: If mode 2 is selected, the keypad V1.0 can no longer be operated on the controller!</b></p>	
Selection list (Lenze setting printed in bold)	Info
0 <b>Mode 1</b>	For keypad V1.0 and V2.0
1 <b>Mode 2</b>	Only for keypad V2.0
<input checked="" type="checkbox"/> Read access <input checked="" type="checkbox"/> Write access <input type="checkbox"/> CINH <input type="checkbox"/> PLC STOP <input type="checkbox"/> No transfer   Scaling factor: 1	

## C00465

Parameter   Name: <b>C00465   Keypad: Timeout welcome screen</b>	Data type: UNSIGNED_8 Index: 24110 <sub>d</sub> = 5E2E <sub>h</sub>
Selection list (Lenze setting printed in bold)	
0 <b>Never show welcome screen</b>	
5 5 min	
15 15 min	
30 30 min	
60 60 min	
<input checked="" type="checkbox"/> Read access <input checked="" type="checkbox"/> Write access <input type="checkbox"/> CINH <input type="checkbox"/> PLC STOP <input type="checkbox"/> No transfer   Scaling factor: 1	

## C00466

Parameter   Name: <b>C00466   Keypad: Default parameter</b>	Data type: UNSIGNED_16 Index: 24109 <sub>d</sub> = 5E2D <sub>h</sub>
Setting range (min. value   unit   max. value)	Lenze setting
0     65535	0
<input checked="" type="checkbox"/> Read access <input checked="" type="checkbox"/> Write access <input type="checkbox"/> CINH <input type="checkbox"/> PLC STOP <input type="checkbox"/> No transfer   Scaling factor: 1	

## C00467

Parameter   Name: <b>C00467   Keypad: Default welcome screen</b>	Data type: UNSIGNED_8 Index: 24108 <sub>d</sub> = 5E2C <sub>h</sub>
Selection list (Lenze setting printed in bold)	
0 <b>Main menu</b>	
1 Parameter list	
<input checked="" type="checkbox"/> Read access <input checked="" type="checkbox"/> Write access <input type="checkbox"/> CINH <input type="checkbox"/> PLC STOP <input type="checkbox"/> No transfer   Scaling factor: 1	

## C00468

Parameter   Name: <b>C00468   Service code</b>	Data type: UNSIGNED_8 Index: 24107 <sub>d</sub> = 5E2B <sub>h</sub>
<b>This code is for device-internal use only and must not be written to by the user!</b>	

## C00469

Parameter   Name: <b>C00469   Keypad: Fct. STOP key</b>	Data type: UNSIGNED_8 Index: 24106 <sub>d</sub> = 5E2A <sub>h</sub>
<b>Selection list</b> (Lenze setting printed in bold)	
0 No function	
1 Inhibit inverter	
<b>2 Activate quick stop</b>	
3 Stop application	
<input checked="" type="checkbox"/> Read access <input checked="" type="checkbox"/> Write access <input type="checkbox"/> CINH <input type="checkbox"/> PLC STOP <input type="checkbox"/> No transfer	Scaling factor: 1

## C00490

Parameter   Name: <b>C00490   Position encoder selection</b>	Data type: UNSIGNED_16 Index: 24085 <sub>d</sub> = 5E15 <sub>h</sub>
Chapter " <a href="#">Controller configuration</a> " provides you with more information on parameter setting.	
<b>Selection list</b> (Lenze setting printed in bold)	
0 Resolver on X7	
1 Encoder on X8	
4 Encoder signal on LS_Feedback	
<b>10 Motor encoder (C00495)</b>	
<input checked="" type="checkbox"/> Read access <input checked="" type="checkbox"/> Write access <input checked="" type="checkbox"/> CINH <input type="checkbox"/> PLC STOP <input type="checkbox"/> No transfer	Scaling factor: 1

## C00494

Parameter   Name: <b>C00494   Motor standstill time constant</b>	Data type: UNSIGNED_32 Index: 24081 <sub>d</sub> = 5E11 <sub>h</sub>
<b>Setting range</b> (min. value   unit   max. value)	<b>Lenze setting</b>
0                      ms                      100000	<b>0 ms</b>
<input checked="" type="checkbox"/> Read access <input checked="" type="checkbox"/> Write access <input type="checkbox"/> CINH <input type="checkbox"/> PLC STOP <input type="checkbox"/> No transfer	Scaling factor: 1

## C00495

Parameter   Name: <b>C00495   Motor encoder selection</b>	Data type: UNSIGNED_16 Index: 24080 <sub>d</sub> = 5E10 <sub>h</sub>
<b>Selection list</b> (Lenze setting printed in bold)	
<b>0 Resolver on X7</b>	
1 Encoder on X8	
<input checked="" type="checkbox"/> Read access <input checked="" type="checkbox"/> Write access <input checked="" type="checkbox"/> CINH <input type="checkbox"/> PLC STOP <input type="checkbox"/> No transfer	Scaling factor: 1

## C00497

Parameter   Name: <b>C00497   Speed act. val. time const.</b>		Data type: UNSIGNED_32 Index: 24078 <sub>d</sub> = 5E0E <sub>h</sub>	
Time constant for actual speed filter			
<ul style="list-style-type: none"> <li>• In order to maximise the dynamics of the speed control loop, the actual speed filter should be operated with a time constant as low as possible. The lower the time constant the higher the gain of the speed controller. Since actual value filters have the task to dampen measuring errors or interference components, it must be found a compromise between filter task and the resulting delay.</li> <li>• If a Lenze motor is selected from the motor catalogue, a time constant is automatically preset here which serves to operate the motor even with a faulty detection (e.g. in case of a bad shield connection). <ul style="list-style-type: none"> <li>▶ Servo control (SC): <a href="#">Optimise speed controller</a></li> <li>▶ Sensorless vector control (SLVC): <a href="#">Optimise speed controller</a></li> </ul> </li> </ul>			
<b>Setting range</b> (min. value   unit   max. value)		<b>Lenze setting</b>	
0.0	ms	50.0	<b>2.0 ms</b>
<input checked="" type="checkbox"/> Read access		<input checked="" type="checkbox"/> Write access	
<input type="checkbox"/> CINH		<input type="checkbox"/> PLC STOP	
<input type="checkbox"/> No transfer		Scaling factor: 10	

## C00512

Parameter   Name: <b>C00512   Service code</b>		Data type: UNSIGNED_32 Index: 24063 <sub>d</sub> = 5DFF <sub>h</sub>	
<b>This code is for device-internal use only and must not be written to by the user!</b>			

## C00513

Parameter   Name: <b>C00513   Service code</b>		Data type: VISIBLE_STRING Index: 24062 <sub>d</sub> = 5DFE <sub>h</sub>	
<b>This code is for device-internal use only and must not be written to by the user!</b>			

## C00514

Parameter   Name: <b>C00514   Service code</b>		Data type: UNSIGNED_32 Index: 24061 <sub>d</sub> = 5DFD <sub>h</sub>	
<b>This code is for device-internal use only and must not be written to by the user!</b>			

## C00515

Parameter   Name: <b>C00515   Service code</b>		Data type: UNSIGNED_32 Index: 24060 <sub>d</sub> = 5DFC <sub>h</sub>	
<b>This code is for device-internal use only and must not be written to by the user!</b>			

## C00516

Parameter   Name: <b>C00516   Service code</b>		Data type: UNSIGNED_32 Index: 24059 <sub>d</sub> = 5DFB <sub>h</sub>	
<b>This code is for device-internal use only and must not be written to by the user!</b>			

**C00569**

Parameter   Name: <b>C00569   Resp. brake trans. ixt &gt; C00570</b>		Data type: UNSIGNED_32 Index: 24006 <sub>d</sub> = 5DC6 <sub>h</sub>
From software version V1.5 Response if adjustable warning threshold ( <a href="#">C00570</a> ) of brake chopper monitoring is reached. <span style="float: right;">▶ <a href="#">Braking operation</a></span>		
<b>Selection list</b> (Lenze setting printed in bold)		
1	Error	
2	Fault	
<b>5</b>	<b>Warning</b>	
4	Warning locked	
3	Quick stop by trouble	
0	No response	
<input checked="" type="checkbox"/> Read access <input checked="" type="checkbox"/> Write access <input type="checkbox"/> CINH <input type="checkbox"/> PLC STOP <input type="checkbox"/> No transfer                   Scaling factor: 1		

**C00570**

Parameter   Name: <b>C00570   Warning thres. brake transistor</b>		Data type: UNSIGNED_32 Index: 24005 <sub>d</sub> = 5DC5 <sub>h</sub>
From software version V1.5 Warning threshold for brake chopper monitoring • The response to reaching the threshold can be selected in <a href="#">C00569</a> . <span style="float: right;">▶ <a href="#">Braking operation</a></span>		
<b>Setting range</b> (min. value   unit   max. value)		<b>Lenze setting</b>
0	%	100
		<b>90 %</b>
<input checked="" type="checkbox"/> Read access <input checked="" type="checkbox"/> Write access <input type="checkbox"/> CINH <input type="checkbox"/> PLC STOP <input type="checkbox"/> No transfer                   Scaling factor: 1		

**C00571**

Parameter   Name: <b>C00571   Resp. to brake res. i<sup>2</sup>xt &gt; C00572</b>		Data type: UNSIGNED_32 Index: 24004 <sub>d</sub> = 5DC4 <sub>h</sub>
From software version V1.5 Response if adjustable warning threshold ( <a href="#">C00572</a> ) of brake resistor monitoring is reached. <span style="float: right;">▶ <a href="#">Braking operation</a></span>		
<b>Selection list</b> (Lenze setting printed in bold)		
1	Error	
2	Fault	
<b>5</b>	<b>Warning</b>	
4	Warning locked	
3	Quick stop by trouble	
0	No response	
<input checked="" type="checkbox"/> Read access <input checked="" type="checkbox"/> Write access <input type="checkbox"/> CINH <input type="checkbox"/> PLC STOP <input type="checkbox"/> No transfer                   Scaling factor: 1		

## C00572

Parameter   Name: <b>C00572   Warning thres. brake resistor</b>		Data type: UNSIGNED_32 Index: 24003 <sub>d</sub> = 5DC3 <sub>h</sub>
From software version V1.5 Warning threshold for brake resistor monitoring <ul style="list-style-type: none"> <li>The response to reaching the threshold can be selected in <a href="#">C00571</a>.</li> </ul> <p style="text-align: right;"><a href="#">▶ Braking operation</a></p>		
<b>Setting range (min. value   unit   max. value)</b>		<b>Lenze setting</b>
0	%	100
		<b>90 %</b>
<input checked="" type="checkbox"/> Read access <input checked="" type="checkbox"/> Write access <input type="checkbox"/> CINH <input type="checkbox"/> PLC STOP <input type="checkbox"/> No transfer		Scaling factor: 1

## C00573

Parameter   Name: <b>C00573   Resp. to overload brake trans.</b>		Data type: UNSIGNED_32 Index: 24002 <sub>d</sub> = 5DC2 <sub>h</sub>
Response to activation of brake chopper monitoring <p style="text-align: right;"><a href="#">▶ Braking operation</a></p>		
<b>Selection list (Lenze setting printed in bold)</b>		
1	Error	
2	Fault	
5	Warning	
4	Warning locked	
3	Quick stop by trouble	
0	<b>No response</b>	
<input checked="" type="checkbox"/> Read access <input checked="" type="checkbox"/> Write access <input type="checkbox"/> CINH <input type="checkbox"/> PLC STOP <input type="checkbox"/> No transfer		Scaling factor: 1

## C00574

Parameter   Name: <b>C00574   Resp. to brake resist. overtemp.</b>		Data type: UNSIGNED_32 Index: 24001 <sub>d</sub> = 5DC1 <sub>h</sub>
Response to activation of brake resistor monitoring <p style="text-align: right;"><a href="#">▶ Braking operation</a></p>		
<b>Selection list (Lenze setting printed in bold)</b>		
1	Error	
2	Fault	
5	Warning	
4	Warning locked	
3	Quick stop by trouble	
0	<b>No response</b>	
<input checked="" type="checkbox"/> Read access <input checked="" type="checkbox"/> Write access <input type="checkbox"/> CINH <input type="checkbox"/> PLC STOP <input type="checkbox"/> No transfer		Scaling factor: 1

## C00576

Parameter   Name: <b>C00576   Speed monitoring tolerance</b>		Data type: UNSIGNED_32 Index: 23999 <sub>d</sub> = 5DBF <sub>h</sub>
Monitoring window for speed control error in [%] of nmax		
<b>Setting range (min. value   unit   max. value)</b>		<b>Lenze setting</b>
0	%	100
		<b>100 %</b>
<input checked="" type="checkbox"/> Read access <input checked="" type="checkbox"/> Write access <input type="checkbox"/> CINH <input type="checkbox"/> PLC STOP <input type="checkbox"/> No transfer		Scaling factor: 1

## C00577

Parameter   Name: <b>C00577   Field weakening controller gain</b>			Data type: UNSIGNED_32 Index: 23998 <sub>d</sub> = 5DBE <sub>h</sub>
At "0" the P component is deactivated, a pure I-controller is used.			
<b>Setting range</b> (min. value   unit   max. value)			<b>Lenze setting</b>
0.000	V <sub>s</sub> /V	2147483.647	<b>0.000 V<sub>s</sub>/V</b>
<input checked="" type="checkbox"/> Read access <input checked="" type="checkbox"/> Write access <input type="checkbox"/> CINH <input type="checkbox"/> PLC STOP <input type="checkbox"/> No transfer			Scaling factor: 1000

## C00578

Parameter   Name: <b>C00578   Field weak. contr. reset time</b>			Data type: UNSIGNED_32 Index: 23997 <sub>d</sub> = 5DBD <sub>h</sub>
At "240000.0 ms" the I component of the field weakening controller is deactivated.			
<b>Setting range</b> (min. value   unit   max. value)			<b>Lenze setting</b>
1.0	ms	240000.0	<b>2000.0 ms</b>
<input checked="" type="checkbox"/> Read access <input checked="" type="checkbox"/> Write access <input type="checkbox"/> CINH <input type="checkbox"/> PLC STOP <input type="checkbox"/> No transfer			Scaling factor: 10

## C00579

Parameter   Name: <b>C00579   Resp. to speed monitoring</b>			Data type: UNSIGNED_32 Index: 23996 <sub>d</sub> = 5DBC <sub>h</sub>
Response to activation of speed monitoring			
<b>Selection list</b> (Lenze setting printed in bold)			
1	Error		
2	Fault		
5	Warning		
4	Warning locked		
3	Quick stop by trouble		
<b>0</b>	<b>No response</b>		
<input checked="" type="checkbox"/> Read access <input checked="" type="checkbox"/> Write access <input type="checkbox"/> CINH <input type="checkbox"/> PLC STOP <input type="checkbox"/> No transfer			Scaling factor: 1

## C00580

Parameter   Name: <b>C00580   Resp. to encoder open circuit</b>			Data type: UNSIGNED_32 Index: 23995 <sub>d</sub> = 5DBB <sub>h</sub>
Response to open circuit in encoder			
<b>⚠ Danger!</b>			
<b>If the encoder is used as motor encoder:</b>			
In the event of a fault, safe operation of the motor is no longer guaranteed!			
For safety reasons, the "Fault" response should always be set for this case!			
<b>Selection list</b> (Lenze setting printed in bold)			
<b>1</b>	<b>Error</b>		
2	Fault		
5	Warning		
4	Warning locked		
3	Quick stop by trouble		
13	Quick Stop open loop by trouble		
0	No response		
<input checked="" type="checkbox"/> Read access <input checked="" type="checkbox"/> Write access <input type="checkbox"/> CINH <input type="checkbox"/> PLC STOP <input type="checkbox"/> No transfer			Scaling factor: 1

## C00581

Parameter   Name: <b>C00581   Resp. to external fault</b>		Data type: UNSIGNED_32 Index: 23994 <sub>d</sub> = 5DBA <sub>h</sub>
Response to an external error		<a href="#">▶ Drive interface</a>
<b>Selection list</b> (Lenze setting printed in bold)		
1	<b>Error</b>	
2	Fault	
3	Quick stop by trouble	
4	Warning locked	
5	Warning	
6	Information	
0	No response	
<input checked="" type="checkbox"/> Read access <input checked="" type="checkbox"/> Write access <input type="checkbox"/> CINH <input type="checkbox"/> PLC STOP <input type="checkbox"/> No transfer		Scaling factor: 1

## C00582

Parameter   Name: <b>C00582   Resp. to heatsink temp. &gt; C00122</b>		Data type: UNSIGNED_32 Index: 23993 <sub>d</sub> = 5DB9 <sub>h</sub>
Response if heatsink temperature > variable limit temperature ( <a href="#">C00122</a> ).		
<b>Selection list</b> (Lenze setting printed in bold)		
1	<b>Error</b>	
5	<b>Warning</b>	
0	No response	
<input checked="" type="checkbox"/> Read access <input checked="" type="checkbox"/> Write access <input type="checkbox"/> CINH <input type="checkbox"/> PLC STOP <input type="checkbox"/> No transfer		Scaling factor: 1

## C00583

Parameter   Name: <b>C00583   Resp. to motor KTY overtemp.</b>		Data type: UNSIGNED_32 Index: 23992 <sub>d</sub> = 5DB8 <sub>h</sub>
Response if motor temperature > fixed limit temperature.		<a href="#">▶ Motor temperature monitoring</a>
<b>Selection list</b> (Lenze setting printed in bold)		
1	<b>Error</b>	
5	Warning	
0	No response	
<input checked="" type="checkbox"/> Read access <input checked="" type="checkbox"/> Write access <input type="checkbox"/> CINH <input type="checkbox"/> PLC STOP <input type="checkbox"/> No transfer		Scaling factor: 1

## C00584

Parameter   Name: <b>C00584   Resp. to motor temp. &gt; C00121</b>		Data type: UNSIGNED_32 Index: 23991 <sub>d</sub> = 5DB7 <sub>h</sub>
Response if motor temperature > variable limit temperature ( <a href="#">C00121</a> ).		<a href="#">▶ Motor temperature monitoring</a>
<b>Selection list</b> (Lenze setting printed in bold)		
1	<b>Error</b>	
5	<b>Warning</b>	
0	No response	
<input checked="" type="checkbox"/> Read access <input checked="" type="checkbox"/> Write access <input type="checkbox"/> CINH <input type="checkbox"/> PLC STOP <input type="checkbox"/> No transfer		Scaling factor: 1



## C00585

Parameter   Name: <b>C00585   Resp. to motor overtemp. PTC</b>		Data type: UNSIGNED_32 Index: 23990 <sub>d</sub> = 5DB6 <sub>h</sub>
Response if motor temperature across PTC input T1/T2 too high.		
<b>Selection list</b> (Lenze setting printed in bold)		
1	Error	
5	Warning	
0	<b>No response</b>	
<input checked="" type="checkbox"/> Read access <input checked="" type="checkbox"/> Write access <input type="checkbox"/> CINH <input type="checkbox"/> PLC STOP <input type="checkbox"/> No transfer		Scaling factor: 1

## C00586

Parameter   Name: <b>C00586   Resp. to resolver open circuit</b>		Data type: UNSIGNED_32 Index: 23989 <sub>d</sub> = 5DB5 <sub>h</sub>
Response to open circuit in resolver <b>⚠ Danger!</b> <b>If the resolver is used as motor encoder:</b> In the event of a fault, safe operation of the motor is no longer guaranteed! For safety reasons, the "Fault" response should always be set for this case!		
<b>Selection list</b> (Lenze setting printed in bold)		
1	<b>Error</b>	
2	Fault	
5	Warning	
4	Warning locked	
3	Quick stop by trouble	
13	Quick Stop open loop by trouble	
0	No response	
<input checked="" type="checkbox"/> Read access <input checked="" type="checkbox"/> Write access <input type="checkbox"/> CINH <input type="checkbox"/> PLC STOP <input type="checkbox"/> No transfer		Scaling factor: 1

## C00587

Parameter   Name: <b>C00587   Fan control status</b>		Data type: BITFIELD_8 Index: 23988 <sub>d</sub> = 5DB4 <sub>h</sub>
<b>Display area</b>		
0x00		0xFF
<b>Value is bit-coded:</b>		
Bit 0	Heatsink fan ON	
Bit 1	Integral fan ON	
Bit 2	Heatsink fan status 1	
Bit 3	Heatsink fan status 2	
Bit 4	Integral fan status	
Bit 5	Reserved	
Bit 6	Reserved	
Bit 7	Reserved	
<input checked="" type="checkbox"/> Read access <input type="checkbox"/> Write access <input type="checkbox"/> CINH <input type="checkbox"/> PLC STOP <input type="checkbox"/> No transfer		Scaling factor: 1

**C00588**

Parameter   Name: <b>C00588   Resp. to failure t. sensor drive</b>		Data type: UNSIGNED_32 Index: 23987 <sub>d</sub> = 5DB3 <sub>h</sub>
Response to error/failure of temperature sensor for heatsink temperature/temperature inside the controller		
<b>Selection list (Lenze setting printed in bold)</b>		
1	<b>Error</b>	
5	Warning	
0	No response	
<input checked="" type="checkbox"/> Read access <input checked="" type="checkbox"/> Write access <input type="checkbox"/> CINH <input type="checkbox"/> PLC STOP <input type="checkbox"/> No transfer		Scaling factor: 1

**C00589**

Parameter   Name: <b>C00589   Resp. to CPU temp. &gt; C00126</b>		Data type: UNSIGNED_32 Index: 23986 <sub>d</sub> = 5DB2 <sub>h</sub>
Response if CPU temperature on the control card > variable limit temperature ( <a href="#">C00126</a> ).		
<b>Selection list (Lenze setting printed in bold)</b>		
1	Error	
5	Warning	
0	<b>No response</b>	
<input checked="" type="checkbox"/> Read access <input checked="" type="checkbox"/> Write access <input type="checkbox"/> CINH <input type="checkbox"/> PLC STOP <input type="checkbox"/> No transfer		Scaling factor: 1

**C00591**

Parameter   Name: <b>C00591   Resp. to CAN-RPDOx error</b>		Data type: UNSIGNED_8 Index: 23984 <sub>d</sub> = 5DB0 <sub>h</sub>
Response if the corresponding CAN RPDO has not been received in the configured time or with the configured sync. ▶ <a href="#">"CAN on board" system bus</a>		
<b>Selection list (Lenze setting printed in bold)</b>		
1	Error	
2	Fault	
3	Quick stop by trouble	
4	Warning locked	
5	Warning	
6	Information	
0	No response	
<b>Subcodes</b>	<b>Lenze setting</b>	<b>Info</b>
C00591/1	0: No Response	Response to non-received RPDO1 ... RPDO4
C00591/...		
C00591/4		
<input checked="" type="checkbox"/> Read access <input checked="" type="checkbox"/> Write access <input type="checkbox"/> CINH <input type="checkbox"/> PLC STOP <input type="checkbox"/> No transfer		Scaling factor: 1

## C00594

Parameter   Name: <b>C00594   Resp. temp. sensor motor X7/X8</b>		Data type: UNSIGNED_32 Index: 23981 <sub>d</sub> = 5DAD <sub>h</sub>
Response to motor temperature sensor error. <ul style="list-style-type: none"> <li>The response to a too high motor temperature via PTC input T1/T2 can be selected in <a href="#">C00585</a>.  ▶ <a href="#">Motor temperature monitoring</a></li> </ul>		
<b>Selection list</b> (Lenze setting printed in bold)		
1	<b>Error</b>	
5	Warning	
0	No response	
<input checked="" type="checkbox"/> Read access <input checked="" type="checkbox"/> Write access <input type="checkbox"/> CINH <input type="checkbox"/> PLC STOP <input type="checkbox"/> No transfer		Scaling factor: 1

## C00595

Parameter   Name: <b>C00595   Resp. to CAN bus OFF</b>		Data type: UNSIGNED_8 Index: 23980 <sub>d</sub> = 5DAC <sub>h</sub>
Response if CAN node switches to the bus-off state. ▶ <a href="#">"CAN on board" system bus</a>		
<b>Selection list</b> (Lenze setting printed in bold)		
1	Error	
2	Fault	
3	Quick stop by trouble	
4	Warning locked	
5	Warning	
6	Information	
0	<b>No response</b>	
<input checked="" type="checkbox"/> Read access <input checked="" type="checkbox"/> Write access <input type="checkbox"/> CINH <input type="checkbox"/> PLC STOP <input type="checkbox"/> No transfer		Scaling factor: 1

## C00596

Parameter   Name: <b>C00596   Threshold max. speed reached</b>		Data type: UNSIGNED_32 Index: 23979 <sub>d</sub> = 5DAB <sub>h</sub>
Threshold for speed monitoring <ul style="list-style-type: none"> <li>The response to reaching the threshold can be selected in <a href="#">C00607</a>.</li> </ul>		
<b>Setting range</b> (min. value   unit   max. value)		<b>Lenze setting</b>
50	rpm	50000
		<b>6500 rpm</b>
<input checked="" type="checkbox"/> Read access <input checked="" type="checkbox"/> Write access <input type="checkbox"/> CINH <input type="checkbox"/> PLC STOP <input type="checkbox"/> No transfer		Scaling factor: 1

## C00597

Parameter   Name: <b>C00597   Resp. to motor phase failure</b>		Data type: UNSIGNED_32 Index: 23978 <sub>d</sub> = 5DAA <sub>h</sub>
Response to activation of motor phase failure monitoring		
<b>Selection list</b> (Lenze setting printed in bold)		
1	Error	
2	Fault	
5	Warning	
4	Warning locked	
3	Quick stop by trouble	
<b>0</b>	<b>No response</b>	
<input checked="" type="checkbox"/> Read access <input checked="" type="checkbox"/> Write access <input type="checkbox"/> CINH <input type="checkbox"/> PLC STOP <input type="checkbox"/> No transfer		Scaling factor: 1

## C00598

Parameter   Name: <b>C00598   Resp. to open circuit AIN1</b>		Data type: UNSIGNED_32 Index: 23978 <sub>d</sub> = 5DA9 <sub>h</sub>
Please observe the following: A response is only triggered when the current is in the range of -2 mA ... +2 mA with a parameterized master current at AIN1 and selection of the "LifeZero" mode ( $\pm 4 \dots \pm 20$ mA).		
<b>Selection list</b> (Lenze setting printed in bold)		
<b>1</b>	<b>Error</b>	
2	Fault	
3	Quick stop by trouble	
4	Warning locked	
5	Warning	
6	Information	
0	No response	
<input checked="" type="checkbox"/> Read access <input checked="" type="checkbox"/> Write access <input type="checkbox"/> CINH <input type="checkbox"/> PLC STOP <input type="checkbox"/> No transfer		Scaling factor: 1

## C00599

Parameter   Name: <b>C00599   Motor phase failure threshold</b>		Data type: INTEGER_32 Index: 23976 <sub>d</sub> = 5DA8 <sub>h</sub>
Current value for activating the <a href="#">Motor phase failure monitoring</a> <ul style="list-style-type: none"> <li>In [%] relating to the maximum device current (display in <a href="#">C00789</a>).</li> <li>The response to be triggered by the monitoring can be selected in <a href="#">C00597</a>.</li> </ul>		
<b>Setting range</b> (min. value   unit   max. value)		<b>Lenze setting</b>
1.0	%	100.0
		<b>5.0 %</b>
<input checked="" type="checkbox"/> Read access <input checked="" type="checkbox"/> Write access <input type="checkbox"/> CINH <input type="checkbox"/> PLC STOP <input type="checkbox"/> No transfer		Scaling factor: 10

## C00600

Parameter   Name: <b>C00600   Resp. to DC bus overvoltage</b>		Data type: UNSIGNED_32 Index: 23975 <sub>d</sub> = 5DA7 <sub>h</sub>
Response to DC bus overvoltage		
<a href="#">▶ Braking operation</a>		
<b>Selection list</b> (Lenze setting printed in bold)		
1	Error	
2	<b>Fault</b>	
<input checked="" type="checkbox"/> Read access <input checked="" type="checkbox"/> Write access <input type="checkbox"/> CINH <input type="checkbox"/> PLC STOP <input type="checkbox"/> No transfer		Scaling factor: 1

## C00601

Parameter   Name: <b>C00601   Resp. to encoder comm. error</b>		Data type: UNSIGNED_32 Index: 23974 <sub>d</sub> = 5DA6 <sub>h</sub>
Response to activation of encoder monitoring		
<ul style="list-style-type: none"> <li>• <b>For the use of the encoder as motor encoder:</b> If an error occurs, the safe operation of the motor is no longer ensured, therefore for safety reasons the "Fault" response should always be set!</li> </ul>		
<b>Selection list</b> (Lenze setting printed in bold)		
1	<b>Error</b>	
2	Fault	
5	Warning	
4	Warning locked	
3	Quick stop by trouble	
13	Quick Stop open loop by trouble	
0	No response	
<input checked="" type="checkbox"/> Read access <input checked="" type="checkbox"/> Write access <input type="checkbox"/> CINH <input type="checkbox"/> PLC STOP <input type="checkbox"/> No transfer		Scaling factor: 1

## C00604

Parameter   Name: <b>C00604   Resp. to device overload &gt; C00123</b>		Data type: UNSIGNED_32 Index: 23971 <sub>d</sub> = 5DA3 <sub>h</sub>
Response if adjustable "I x t" warning threshold ( <a href="#">C00123</a> ) is reached.		
<b>Selection list</b> (Lenze setting printed in bold)		
1	Error	
5	<b>Warning</b>	
0	No response	
<input checked="" type="checkbox"/> Read access <input checked="" type="checkbox"/> Write access <input type="checkbox"/> CINH <input type="checkbox"/> PLC STOP <input type="checkbox"/> No transfer		Scaling factor: 1

## C00606

Parameter   Name: <b>C00606   Resp. to motor overload &gt; C00127</b>		Data type: UNSIGNED_32 Index: 23969 <sub>d</sub> = 5DA1 <sub>h</sub>
Response if adjustable "I <sup>2</sup> x t" warning threshold ( <a href="#">C00127</a> ) is reached.		
<a href="#">▶ I<sup>2</sup>x t motor monitoring</a>		
<b>Selection list</b> (Lenze setting printed in bold)		
1	Error	
5	<b>Warning</b>	
0	No response	
<input checked="" type="checkbox"/> Read access <input checked="" type="checkbox"/> Write access <input type="checkbox"/> CINH <input type="checkbox"/> PLC STOP <input type="checkbox"/> No transfer		Scaling factor: 1

## C00607

Parameter   Name: <b>C00607   Resp. to max. speed reached</b>		Data type: UNSIGNED_32 Index: 23968 <sub>d</sub> = 5DA0 <sub>h</sub>
Response if adjustable speed threshold ( <a href="#">C00596</a> ) is reached.		
<b>Selection list</b> (Lenze setting printed in bold)		
<b>1</b>	<b>Error</b>	
2	Fault	
5	Warning	
4	Warning locked	
3	Quick stop by trouble	
0	No response	
<input checked="" type="checkbox"/> Read access <input checked="" type="checkbox"/> Write access <input type="checkbox"/> CINH <input type="checkbox"/> PLC STOP <input type="checkbox"/> No transfer		Scaling factor: 1

## C00610

Parameter   Name: <b>C00610   Resp. to failure heatsink fan</b>		Data type: UNSIGNED_32 Index: 23965 <sub>d</sub> = 5D9D <sub>h</sub>
Response if fan speed of heatsink fan is too low.		
<b>Selection list</b> (Lenze setting printed in bold)		
<b>1</b>	<b>Error</b>	
5	Warning	
0	No response	
<input checked="" type="checkbox"/> Read access <input checked="" type="checkbox"/> Write access <input type="checkbox"/> CINH <input type="checkbox"/> PLC STOP <input type="checkbox"/> No transfer		Scaling factor: 1

## C00611

Parameter   Name: <b>C00611   Resp. to failure integral fan</b>		Data type: UNSIGNED_32 Index: 23964 <sub>d</sub> = 5D9C <sub>h</sub>
Response if fan speed of internal fan is too low.		
<b>Selection list</b> (Lenze setting printed in bold)		
<b>1</b>	<b>Error</b>	
5	Warning	
0	No response	
<input checked="" type="checkbox"/> Read access <input checked="" type="checkbox"/> Write access <input type="checkbox"/> CINH <input type="checkbox"/> PLC STOP <input type="checkbox"/> No transfer		Scaling factor: 1

C00612

Parameter   Name: <b>C00612   Resp. to CAN node guarding error</b>		Data type: UNSIGNED_8 Index: 23963 <sub>d</sub> = 5D9B <sub>h</sub>
Response of master if the corresponding node guarding response is missing. <div style="text-align: right;"><a href="#">▶ "CAN on board" system bus: node guarding protocol</a></div>		
Selection list (Lenze setting printed in bold)		
1	Error	
2	Fault	
3	Quick stop by trouble	
4	Warning locked	
5	Warning	
6	Information	
0	No response	
Subcodes	Lenze setting	Info
C00612/1	0: No Response	Response to non-received telegram for monitoring entry 1 ... 32
C00612/...		
C00612/32		
<input checked="" type="checkbox"/> Read access <input checked="" type="checkbox"/> Write access <input type="checkbox"/> CINH <input type="checkbox"/> PLC STOP <input type="checkbox"/> No transfer		Scaling factor: 1

C00613

Parameter   Name: <b>C00613   Resp. to CAN heartbeat error</b>		Data type: UNSIGNED_8 Index: 23962 <sub>d</sub> = 5D9A <sub>h</sub>
Response if the corresponding heartbeat telegram is missing. <div style="text-align: right;"><a href="#">▶ "CAN on board" system bus: heartbeat protocol</a></div>		
Selection list (Lenze setting printed in bold)		
1	Error	
2	Fault	
3	Quick stop by trouble	
4	Warning locked	
5	Warning	
6	Information	
0	No response	
Subcodes	Lenze setting	Info
C00613/1	0: No Response	Response to non-received telegram for monitoring entry 1 ... 32
C00613/...		
C00613/32		
<input checked="" type="checkbox"/> Read access <input checked="" type="checkbox"/> Write access <input type="checkbox"/> CINH <input type="checkbox"/> PLC STOP <input type="checkbox"/> No transfer		Scaling factor: 1

**C00614**

Parameter   Name: <b>C00614   Resp. to CAN life guarding error</b>		Data type: UNSIGNED_8 Index: 23961 <sub>d</sub> = 5D99 <sub>h</sub>
Response of slave if node guarding request is missing.		
<a href="#">▶ "CAN on board" system bus: node guarding protocol</a>		
Selection list (Lenze setting printed in bold)		
1	Error	
2	Fault	
3	Quick stop by trouble	
4	Warning locked	
5	Warning	
6	Information	
<b>0</b>	<b>No response</b>	
<input checked="" type="checkbox"/> Read access <input checked="" type="checkbox"/> Write access <input type="checkbox"/> CINH <input type="checkbox"/> PLC STOP <input type="checkbox"/> No transfer		Scaling factor: 1

**C00615**

Parameter   Name: <b>C00615   Resp. to imp. device conf.</b>		Data type: UNSIGNED_32 Index: 23960 <sub>d</sub> = 5D98 <sub>h</sub>
Selection list		
1	Error	
3	Quick stop by trouble	
4	Warning locked	
6	Information	
0	No response	
Subcodes	Lenze setting	Info
C00615/1	0: No Response	Reserved
C00615/2	1: Error	Resp. to imp. module in MXI1
C00615/3	1: Error	Resp. to imp. module in MXI2
C00615/4	0: No Response	Reserved
C00615/5	0: No Response	Reserved
<input checked="" type="checkbox"/> Read access <input checked="" type="checkbox"/> Write access <input type="checkbox"/> CINH <input type="checkbox"/> PLC STOP <input type="checkbox"/> No transfer		Scaling factor: 1

**C00618**

Parameter   Name: <b>C00618   No. of CRC cycles</b>		Data type: UNSIGNED_32 Index: 23957 <sub>d</sub> = 5D95 <sub>h</sub>
Display range (min. value   unit   max. value)		
0	4294967295	
<input checked="" type="checkbox"/> Read access <input type="checkbox"/> Write access <input type="checkbox"/> CINH <input type="checkbox"/> PLC STOP <input type="checkbox"/> No transfer		Scaling factor: 1



## C00619

Parameter   Name:		Data type: UNSIGNED_32 Index: 23956 <sub>d</sub> = 5D94 <sub>h</sub>
<b>C00619   Resp. to motor current &gt; C00620</b>		
Response if the ultimate motor current I <sub>ult</sub> parameterised in <a href="#">C00620</a> is reached.		
Selection list (Lenze setting printed in bold)		
1	<b>Error</b>	
2	Fault	
5	Warning	
4	Warning locked	
3	Quick stop by trouble	
0	No response	
<input checked="" type="checkbox"/> Read access <input checked="" type="checkbox"/> Write access <input type="checkbox"/> CINH <input type="checkbox"/> PLC STOP <input type="checkbox"/> No transfer		Scaling factor: 1

## C00620

Parameter   Name:		Data type: UNSIGNED_32 Index: 23955 <sub>d</sub> = 5D93 <sub>h</sub>
<b>C00620   Ultimate motor current I<sub>ult</sub></b>		
Limit value to protect the motor from destruction or influence of the rated data. <ul style="list-style-type: none"> <li>• This limit value must not be travelled cyclically in the drive process.</li> <li>• The maximum current parameterisable in <a href="#">C00022</a> should have a sufficient distance from this limit value.</li> <li>• If the set limit value is exceeded, the error response parameterised in <a href="#">C00619</a> is carried out for motor protection.</li> </ul>		
Setting range (min. value   unit   max. value)		Lenze setting
0.0	A	3000.0
		<b>3000.0 A</b>
<input checked="" type="checkbox"/> Read access <input checked="" type="checkbox"/> Write access <input type="checkbox"/> CINH <input type="checkbox"/> PLC STOP <input type="checkbox"/> No transfer		Scaling factor: 10

## C00621

Parameter   Name:		Data type: UNSIGNED_32 Index: 23954 <sub>d</sub> = 5D92 <sub>h</sub>
<b>C00621   Resp. to encoder pulse deviation</b>		
From software version V1.5 Response to be triggered by angular drift monitoring		
		<a href="#">▶ Angular drift monitoring</a>
Selection list (Lenze setting printed in bold)		
1	<b>Error</b>	
2	Fault	
5	Warning	
4	Warning locked	
3	Quick stop by trouble	
13	Quick Stop open loop by trouble	
0	<b>No response</b>	
<input checked="" type="checkbox"/> Read access <input checked="" type="checkbox"/> Write access <input type="checkbox"/> CINH <input type="checkbox"/> PLC STOP <input type="checkbox"/> No transfer		Scaling factor: 1

## C00625

Parameter   Name: <b>C00625   CAN behaviour in case of fault</b>		Data type: UNSIGNED_8 Index: 23950 <sub>d</sub> = 5D8E <sub>h</sub>
Mapping of the CANopen object <a href="#">I-1029</a> (see DS301 V4.02). <a href="#">▶ "CAN on board" system bus</a>		
<b>Selection list</b> (Lenze setting printed in bold)		
0	<b>Pre-operational state</b>	
1	No state change	
2	Stopped state	
<input checked="" type="checkbox"/> Read access <input checked="" type="checkbox"/> Write access <input type="checkbox"/> CINH <input type="checkbox"/> PLC STOP <input type="checkbox"/> No transfer		Scaling factor: 1

## C00635

Parameter   Name: <b>C00635   Resp to new firmw. standard dev.</b>		Data type: UNSIGNED_32 Index: 23940 <sub>d</sub> = 5D84 <sub>h</sub>
<b>Selection list</b> (Lenze setting printed in bold)		
1	<b>Error</b>	
6	Information	
5	Warning	
4	Warning locked	
3	Quick stop by trouble	
0	No response	
<input checked="" type="checkbox"/> Read access <input checked="" type="checkbox"/> Write access <input type="checkbox"/> CINH <input type="checkbox"/> PLC STOP <input type="checkbox"/> No transfer		Scaling factor: 1

## C00636

Parameter   Name: <b>C00636   Resp. to new module in MX1</b>		Data type: UNSIGNED_32 Index: 23939 <sub>d</sub> = 5D83 <sub>h</sub>
<b>Selection list</b> (Lenze setting printed in bold)		
1	Error	
6	Information	
5	Warning	
4	<b>Warning locked</b>	
3	Quick stop by trouble	
0	No response	
<input checked="" type="checkbox"/> Read access <input checked="" type="checkbox"/> Write access <input type="checkbox"/> CINH <input type="checkbox"/> PLC STOP <input type="checkbox"/> No transfer		Scaling factor: 1

## C00637

Parameter   Name: <b>C00637   Resp. to new module in MX12</b>		Data type: UNSIGNED_32 Index: 23938 <sub>d</sub> = 5D82 <sub>h</sub>
<b>Selection list</b> (Lenze setting printed in bold)		
1	Error	
6	Information	
5	Warning	
4	<b>Warning locked</b>	
3	Quick stop by trouble	
0	No response	
<input checked="" type="checkbox"/> Read access <input checked="" type="checkbox"/> Write access <input type="checkbox"/> CINH <input type="checkbox"/> PLC STOP <input type="checkbox"/> No transfer		Scaling factor: 1

## C00640

Parameter   Name: <b>C00640   Resp. to pole pos. id. monit.</b>		Data type: UNSIGNED_32 Index: 23935 <sub>d</sub> = 5D7F <sub>h</sub>
From software version V4.0 Error response for abort of the <a href="#">pole position identification</a> <a href="#">▶ Adjustment of the pole position identification</a>		
<b>Selection list</b> (Lenze setting printed in bold)		
1	<b>Error</b>	
4	Warning locked	
0	No response	
<input checked="" type="checkbox"/> Read access <input checked="" type="checkbox"/> Write access <input type="checkbox"/> CINH <input type="checkbox"/> PLC STOP <input type="checkbox"/> No transfer		Scaling factor: 1

## C00641

Parameter   Name: <b>C00641   PLI 360° current amplitude</b>		Data type: UNSIGNED_32 Index: 23934 <sub>d</sub> = 5D7E <sub>h</sub>
From software version V4.0 Percentage adjustment of the current amplitude for the <a href="#">pole position identification</a> <b>Stop!</b> If there is no temperature monitoring in the motor and/or the I2xt motor monitoring is not parameterised correctly, the motor may be permanently damaged when the current amplitude is set too high (e.g. to the maximum value)! <a href="#">▶ Adjustment of the pole position identification</a>		
<b>Setting range</b> (min. value   unit   max. value)		<b>Lenze setting</b>
1	%	1000
<input checked="" type="checkbox"/> Read access <input checked="" type="checkbox"/> Write access <input type="checkbox"/> CINH <input type="checkbox"/> PLC STOP <input type="checkbox"/> No transfer		Scaling factor: 1

## C00642

Parameter   Name: <b>C00642   PolePosId 360° ramp time</b>		Data type: UNSIGNED_32 Index: 23933 <sub>d</sub> = 5D7D <sub>h</sub>
From software version V4.0 Percentage adjustment of the ramp time for the <a href="#">pole position identification</a> <a href="#">▶ Adjustment of the pole position identification</a>		
<b>Setting range</b> (min. value   unit   max. value)		<b>Lenze setting</b>
5	%	1000
<input checked="" type="checkbox"/> Read access <input checked="" type="checkbox"/> Write access <input type="checkbox"/> CINH <input type="checkbox"/> PLC STOP <input type="checkbox"/> No transfer		Scaling factor: 1

## C00643

Parameter   Name: <b>C00643   PLI 360° traversing direction</b>		Data type: UNSIGNED_32 Index: 23932 <sub>d</sub> = 5D7C <sub>h</sub>
From software version V4.0 Selection of the traversing direction for the <a href="#">pole position identification</a> <a href="#">▶ Adjustment of the pole position identification</a>		
<b>Selection list</b> (Lenze setting printed in bold)		
0	<b>Right rotating field</b>	
1	Left rotating field	
<input checked="" type="checkbox"/> Read access <input checked="" type="checkbox"/> Write access <input type="checkbox"/> CINH <input type="checkbox"/> PLC STOP <input type="checkbox"/> No transfer		Scaling factor: 1

## C00644

Parameter   Name: <b>C00644   PolePosId 360° fault tol.</b>			Data type: INTEGER_32 Index: 23931 <sub>d</sub> = 5D7B <sub>h</sub>	
From software version V4.0 Fault tolerance for the plausibility check of the <a href="#">pole position identification</a> ▶ <a href="#">Adjustment of the pole position identification</a>				
<b>Setting range (min. value   unit   max. value)</b>			<b>Lenze setting</b>	
-6.0	°	30.0	0.0 °	
<input checked="" type="checkbox"/> Read access <input checked="" type="checkbox"/> Write access <input type="checkbox"/> CINH <input type="checkbox"/> PLC STOP <input type="checkbox"/> No transfer			Scaling factor: 10	

## C00645

Parameter   Name: <b>C00645   PLI 360° absolute current amplitude</b>			Data type: UNSIGNED_32 Index: 23930 <sub>d</sub> = 5D7A <sub>h</sub>	
From software version V7.0 ▶ <a href="#">Adjustment of the pole position identification</a>				
<b>Display range (min. value   unit   max. value)</b>				
0.00	A	1000.00		
<input checked="" type="checkbox"/> Read access <input type="checkbox"/> Write access <input type="checkbox"/> CINH <input type="checkbox"/> PLC STOP <input type="checkbox"/> No transfer			Scaling factor: 100	

## C00646

Parameter   Name: <b>C00646   PLI min.mov. curr. amplitude</b>			Data type: UNSIGNED_32 Index: 23929 <sub>d</sub> = 5D79 <sub>h</sub>	
From software version V4.0 Percentage adjustment of the current amplitude for the <a href="#">pole position identification</a> <b>Stop!</b> If there is no temperature monitoring in the motor and/or the I2xt motor monitoring is not parameterised correctly, the motor may be permanently damaged when the current amplitude is set too high (e.g. to the maximum value)! ▶ <a href="#">Adjustment of the pole position identification</a>				
<b>Setting range (min. value   unit   max. value)</b>			<b>Lenze setting</b>	
1	%	1000	100 %	
<input checked="" type="checkbox"/> Read access <input checked="" type="checkbox"/> Write access <input type="checkbox"/> CINH <input type="checkbox"/> PLC STOP <input type="checkbox"/> No transfer			Scaling factor: 1	

## C00647

Parameter   Name: <b>C00647   PolePosId min.mov. cur.rise rate</b>			Data type: UNSIGNED_32 Index: 23928 <sub>d</sub> = 5D78 <sub>h</sub>	
From software version V4.0 Percentage adjustment of the rate of current rise for the <a href="#">pole position identification</a> ▶ <a href="#">Adjustment of the pole position identification</a>				
<b>Setting range (min. value   unit   max. value)</b>			<b>Lenze setting</b>	
5	%	1000	100 %	
<input checked="" type="checkbox"/> Read access <input checked="" type="checkbox"/> Write access <input type="checkbox"/> CINH <input type="checkbox"/> PLC STOP <input type="checkbox"/> No transfer			Scaling factor: 1	

## C00648

Parameter   Name: <b>C00648   PolePosId min.mov. gain</b>		Data type: UNSIGNED_32 Index: 23927 <sub>d</sub> = 5D77 <sub>h</sub>	
From software version V4.0 P component of the PI controller for the <a href="#">pole position identification</a> ▶ <a href="#">Adjustment of the pole position identification</a>			
<b>Setting range (min. value   unit   max. value)</b>		<b>Lenze setting</b>	
0.00		10.00	<b>0.00</b>
<input checked="" type="checkbox"/> Read access <input checked="" type="checkbox"/> Write access <input type="checkbox"/> CINH <input type="checkbox"/> PLC STOP <input type="checkbox"/> No transfer		Scaling factor: 100	

## C00649

Parameter   Name: <b>C00649   PLI min. mov. reset time</b>		Data type: UNSIGNED_32 Index: 23926 <sub>d</sub> = 5D76 <sub>h</sub>	
From software version V4.0 I component of the PI controller for the <a href="#">pole position identification</a> ▶ <a href="#">Adjustment of the pole position identification</a>			
<b>Setting range (min. value   unit   max. value)</b>		<b>Lenze setting</b>	
0.01	ms	6000.00	<b>62.50 ms</b>
<input checked="" type="checkbox"/> Read access <input checked="" type="checkbox"/> Write access <input type="checkbox"/> CINH <input type="checkbox"/> PLC STOP <input type="checkbox"/> No transfer		Scaling factor: 100	

## C00650

Parameter   Name: <b>C00650   PolePosId min.mov. max.perm.mov.</b>		Data type: INTEGER_32 Index: 23925 <sub>d</sub> = 5D75 <sub>h</sub>	
From software version V4.0 Max. movement permitted during the <a href="#">pole position identification</a> ▶ <a href="#">Adjustment of the pole position identification</a>			
<b>Setting range (min. value   unit   max. value)</b>		<b>Lenze setting</b>	
1	°	90	<b>20 °</b>
<input checked="" type="checkbox"/> Read access <input checked="" type="checkbox"/> Write access <input type="checkbox"/> CINH <input type="checkbox"/> PLC STOP <input type="checkbox"/> No transfer		Scaling factor: 1	

## C00651

Parameter   Name: <b>C00651   PLI min. motion absolute cur. amp.</b>		Data type: UNSIGNED_32 Index: 23924 <sub>d</sub> = 5D74 <sub>h</sub>	
From software version V7.0 ▶ <a href="#">Adjustment of the pole position identification</a>			
<b>Display range (min. value   unit   max. value)</b>			
0.00	A	1000.00	
<input checked="" type="checkbox"/> Read access <input type="checkbox"/> Write access <input type="checkbox"/> CINH <input type="checkbox"/> PLC STOP <input type="checkbox"/> No transfer		Scaling factor: 100	

## C00658

Parameter   Name: <b>C00658   Noise signal amplitude</b>		Data type: UNSIGNED_32 Index: 23917 <sub>d</sub> = 5D6D <sub>h</sub>	
<b>This code is for device-internal use only and must not be written to by the user!</b>			

## C00659

Parameter   Name: <b>C00659   Noise signal period</b>	Data type: UNSIGNED_32 Index: 23916 <sub>d</sub> = 5D6C <sub>h</sub>
<b>This code is for device-internal use only and must not be written to by the user!</b>	

## C00691

Parameter   Name: <b>C00691   Total speed setpoint</b>	Data type: INTEGER_32 Index: 23884 <sub>d</sub> = 5D4C <sub>h</sub>
<b>Display range (min. value   unit   max. value)</b>	
-200.00      %      200.00	
<input checked="" type="checkbox"/> Read access <input type="checkbox"/> Write access <input type="checkbox"/> CINH <input type="checkbox"/> PLC STOP <input type="checkbox"/> No transfer      Scaling factor: 100	

## C00692

Parameter   Name: <b>C00692   Speed setpoint [%]</b>	Data type: INTEGER_32 Index: 23883 <sub>d</sub> = 5D4B <sub>h</sub>
<b>Display range (min. value   unit   max. value)</b>	
-200.00      %      200.00	
<input checked="" type="checkbox"/> Read access <input type="checkbox"/> Write access <input type="checkbox"/> CINH <input type="checkbox"/> PLC STOP <input type="checkbox"/> No transfer      Scaling factor: 100	

## C00693

Parameter   Name: <b>C00693   Actual speed [%]</b>	Data type: INTEGER_32 Index: 23882 <sub>d</sub> = 5D4A <sub>h</sub>
<b>Display range (min. value   unit   max. value)</b>	
-200.00      %      200.00	
<input checked="" type="checkbox"/> Read access <input type="checkbox"/> Write access <input type="checkbox"/> CINH <input type="checkbox"/> PLC STOP <input type="checkbox"/> No transfer      Scaling factor: 100	

## C00694

Parameter   Name: <b>C00694   Speed controller output</b>	Data type: INTEGER_32 Index: 23881 <sub>d</sub> = 5D49 <sub>h</sub>
<b>Display range (min. value   unit   max. value)</b>	
-200.00      %      200.00	
<input checked="" type="checkbox"/> Read access <input type="checkbox"/> Write access <input type="checkbox"/> CINH <input type="checkbox"/> PLC STOP <input type="checkbox"/> No transfer      Scaling factor: 100	

## C00695

Parameter   Name: <b>C00695   Total torque setpoint</b>	Data type: INTEGER_32 Index: 23880 <sub>d</sub> = 5D48 <sub>h</sub>
<b>Display range (min. value   unit   max. value)</b>	
-200.00      %      200.00	
<input checked="" type="checkbox"/> Read access <input type="checkbox"/> Write access <input type="checkbox"/> CINH <input type="checkbox"/> PLC STOP <input type="checkbox"/> No transfer      Scaling factor: 100	

## C00696

Parameter   Name: <b>C00696   Torque setpoint [%]</b>	Data type: INTEGER_32 Index: 23879 <sub>d</sub> = 5D47 <sub>h</sub>
<b>Display range (min. value   unit   max. value)</b>	
-200.00      %      200.00	
<input checked="" type="checkbox"/> Read access <input type="checkbox"/> Write access <input type="checkbox"/> CINH <input type="checkbox"/> PLC STOP <input type="checkbox"/> No transfer      Scaling factor: 100	

## C00697

Parameter   Name: <b>C00697   Filtered torque setpoint</b>		Data type: INTEGER_32 Index: 23878 <sub>d</sub> = 5D46 <sub>h</sub>
Display range (min. value   unit   max. value)		
-200.00	%	200.00
<input checked="" type="checkbox"/> Read access <input type="checkbox"/> Write access <input type="checkbox"/> CINH <input type="checkbox"/> PLC STOP <input type="checkbox"/> No transfer		Scaling factor: 100

## C00698

Parameter   Name: <b>C00698   Actual torque [%]</b>		Data type: INTEGER_32 Index: 23877 <sub>d</sub> = 5D45 <sub>h</sub>
Display range (min. value   unit   max. value)		
-200.00	%	200.00
<input checked="" type="checkbox"/> Read access <input type="checkbox"/> Write access <input type="checkbox"/> CINH <input type="checkbox"/> PLC STOP <input type="checkbox"/> No transfer		Scaling factor: 100

## C00730

Parameter   Name: <b>C00730   GDO general parameters</b>		Data type: INTEGER_32 Index: 23845 <sub>d</sub> = 5D25 <sub>h</sub>
<b>This code is for device-internal use only and must not be written to by the user!</b>		

## C00731

Parameter   Name: <b>C00731   GDO channel 1/trigger 1</b>		Data type: INTEGER_32 Index: 23844 <sub>d</sub> = 5D24 <sub>h</sub>
<b>This code is for device-internal use only and must not be written to by the user!</b>		

## C00732

Parameter   Name: <b>C00732   GDO channel 2/trigger 2</b>		Data type: INTEGER_32 Index: 23843 <sub>d</sub> = 5D23 <sub>h</sub>
<b>This code is for device-internal use only and must not be written to by the user!</b>		

## C00733

Parameter   Name: <b>C00733   GDO channel 3</b>		Data type: INTEGER_32 Index: 23842 <sub>d</sub> = 5D22 <sub>h</sub>
<b>This code is for device-internal use only and must not be written to by the user!</b>		

## C00734

Parameter   Name: <b>C00734   GDO channel 4</b>		Data type: INTEGER_32 Index: 23841 <sub>d</sub> = 5D21 <sub>h</sub>
<b>This code is for device-internal use only and must not be written to by the user!</b>		

## C00735

Parameter   Name: <b>C00735   GDO channel 5</b>		Data type: INTEGER_32 Index: 23840 <sub>d</sub> = 5D20 <sub>h</sub>
<b>This code is for device-internal use only and must not be written to by the user!</b>		

## C00736

Parameter   Name: <b>C00736   GDO channel 6</b>	Data type: INTEGER_32 Index: 23839 <sub>d</sub> = 5D1F <sub>h</sub>
<b>This code is for device-internal use only and must not be written to by the user!</b>	

## C00737

Parameter   Name: <b>C00737   GDO channel 7</b>	Data type: INTEGER_32 Index: 23838 <sub>d</sub> = 5D1E <sub>h</sub>
<b>This code is for device-internal use only and must not be written to by the user!</b>	

## C00738

Parameter   Name: <b>C00738   GDO channel 8</b>	Data type: INTEGER_32 Index: 23837 <sub>d</sub> = 5D1D <sub>h</sub>
<b>This code is for device-internal use only and must not be written to by the user!</b>	

## C00739

Parameter   Name: <b>C00739   GDO status information</b>	Data type: INTEGER_32 Index: 23836 <sub>d</sub> = 5D1C <sub>h</sub>
<b>This code is for device-internal use only and must not be written to by the user!</b>	

## C00770

Parameter   Name: <b>C00770   MCTRL_dnMotorPosAct</b>	Data type: UNSIGNED_32 Index: 23805 <sub>d</sub> = 5CFD <sub>h</sub>
Internal motor control (MCTRL) signal	
<b>Display range (min. value   unit   max. value)</b>	
0	Incr. 4294967295
<b>Subcodes</b>	<b>Info</b>
C00770/1	LOW word
C00770/2	High word
<input checked="" type="checkbox"/> Read access <input type="checkbox"/> Write access <input type="checkbox"/> CINH <input type="checkbox"/> PLC STOP <input type="checkbox"/> No transfer           Scaling factor: 1	

## C00771

Parameter   Name: <b>C00771   MCTRL_dnLoadPosAct</b>	Data type: UNSIGNED_32 Index: 23804 <sub>d</sub> = 5CFE <sub>h</sub>
Internal motor control (MCTRL) signal	
<b>Display range (min. value   unit   max. value)</b>	
0	Incr. 4294967295
<b>Subcodes</b>	<b>Info</b>
C00771/1	LOW word
C00771/2	High word
<input checked="" type="checkbox"/> Read access <input type="checkbox"/> Write access <input type="checkbox"/> CINH <input type="checkbox"/> PLC STOP <input type="checkbox"/> No transfer           Scaling factor: 1	



## C00772

Parameter   Name: <b>C00772   MCTRL_dnMotorSpeedAct</b>			Data type: INTEGER_32 Index: 23803 <sub>d</sub> = 5CFB <sub>h</sub>
Internal motor control (MCTRL) signal			
<b>Display range (min. value   unit   max. value)</b>			
-480000	rpm	480000	
<input checked="" type="checkbox"/> Read access <input type="checkbox"/> Write access <input type="checkbox"/> CINH <input type="checkbox"/> PLC STOP <input type="checkbox"/> No transfer			Scaling factor: 1

## C00773

Parameter   Name: <b>C00773   MCTRL_dnLoadSpeedAct</b>			Data type: INTEGER_32 Index: 23802 <sub>d</sub> = 5CFA <sub>h</sub>
Internal motor control (MCTRL) signal			
<b>Display range (min. value   unit   max. value)</b>			
-480000	rpm	480000	
<input checked="" type="checkbox"/> Read access <input type="checkbox"/> Write access <input type="checkbox"/> CINH <input type="checkbox"/> PLC STOP <input type="checkbox"/> No transfer			Scaling factor: 1

## C00774

Parameter   Name: <b>C00774   MCTRL_dnTorqueAct</b>			Data type: INTEGER_32 Index: 23801 <sub>d</sub> = 5CF9 <sub>h</sub>
Internal motor control (MCTRL) signal			
<b>Display range (min. value   unit   max. value)</b>			
-21474836.47	Nm	21474836.47	
<input checked="" type="checkbox"/> Read access <input type="checkbox"/> Write access <input type="checkbox"/> CINH <input type="checkbox"/> PLC STOP <input type="checkbox"/> No transfer			Scaling factor: 100

## C00775

Parameter   Name: <b>C00775   MCTRL_dnOutputSpeedCtrl</b>			Data type: INTEGER_32 Index: 23800 <sub>d</sub> = 5CF8 <sub>h</sub>
Internal motor control (MCTRL) signal			
<b>Display range (min. value   unit   max. value)</b>			
-21474836.47	Nm	21474836.47	
<input checked="" type="checkbox"/> Read access <input type="checkbox"/> Write access <input type="checkbox"/> CINH <input type="checkbox"/> PLC STOP <input type="checkbox"/> No transfer			Scaling factor: 100

## C00776

Parameter   Name: <b>C00776   MCTRL_dnInputJerkCtrl</b>			Data type: INTEGER_32 Index: 23799 <sub>d</sub> = 5CF7 <sub>h</sub>
Internal motor control (MCTRL) signal			
<b>Display range (min. value   unit   max. value)</b>			
-21474836.47	Nm	21474836.47	
<input checked="" type="checkbox"/> Read access <input type="checkbox"/> Write access <input type="checkbox"/> CINH <input type="checkbox"/> PLC STOP <input type="checkbox"/> No transfer			Scaling factor: 100

## C00777

Parameter   Name: <b>C00777   MCTRL_dnInputTorqueCtrl</b>			Data type: INTEGER_32 Index: 23798 <sub>d</sub> = 5CF6 <sub>h</sub>
Internal motor control (MCTRL) signal			
<b>Display range (min. value   unit   max. value)</b>			
-21474836.47	Nm	21474836.47	
<input checked="" type="checkbox"/> Read access <input type="checkbox"/> Write access <input type="checkbox"/> CINH <input type="checkbox"/> PLC STOP <input type="checkbox"/> No transfer			Scaling factor: 100

## C00778

Parameter   Name: <b>C00778   MCTRL_dnFluxAct</b>			Data type: INTEGER_32 Index: 23797 <sub>d</sub> = 5CF5 <sub>h</sub>
Internal motor control (MCTRL) signal			
<b>Display range (min. value   unit   max. value)</b>			
-200.00	%	200.00	
<input checked="" type="checkbox"/> Read access <input type="checkbox"/> Write access <input type="checkbox"/> CINH <input type="checkbox"/> PLC STOP <input type="checkbox"/> No transfer			Scaling factor: 100

## C00779

Parameter   Name: <b>C00779   MCTRL_dnDCBusVoltage</b>			Data type: INTEGER_32 Index: 23796 <sub>d</sub> = 5CF4 <sub>h</sub>
Internal motor control (MCTRL) signal			
<b>Display range (min. value   unit   max. value)</b>			
0	V	1000	
<input checked="" type="checkbox"/> Read access <input type="checkbox"/> Write access <input type="checkbox"/> CINH <input type="checkbox"/> PLC STOP <input type="checkbox"/> No transfer			Scaling factor: 1

## C00780

Parameter   Name: <b>C00780   MCTRL_dnImotAct</b>			Data type: INTEGER_32 Index: 23795 <sub>d</sub> = 5CF3 <sub>h</sub>
Internal motor control (MCTRL) signal			
<b>Display range (min. value   unit   max. value)</b>			
-500.00	A	500.00	
<input checked="" type="checkbox"/> Read access <input type="checkbox"/> Write access <input type="checkbox"/> CINH <input type="checkbox"/> PLC STOP <input type="checkbox"/> No transfer			Scaling factor: 100

## C00781

Parameter   Name: <b>C00781   MCTRL_dwMaxMotorSpeed</b>			Data type: UNSIGNED_32 Index: 23794 <sub>d</sub> = 5CF2 <sub>h</sub>
Internal motor control (MCTRL) signal			
<b>Display range (min. value   unit   max. value)</b>			
0	rpm	480000	
<input checked="" type="checkbox"/> Read access <input type="checkbox"/> Write access <input type="checkbox"/> CINH <input type="checkbox"/> PLC STOP <input type="checkbox"/> No transfer			Scaling factor: 1

## C00782

Parameter   Name: <b>C00782   MCTRL_dwMaxMotorTorque</b>		Data type: UNSIGNED_32 Index: 23793 <sub>d</sub> = 5CF1 <sub>h</sub>
Internal motor control (MCTRL) signal		
<b>Display range (min. value   unit   max. value)</b>		
0.000	Nm	2147483.647
<input checked="" type="checkbox"/> Read access <input type="checkbox"/> Write access <input type="checkbox"/> CINH <input type="checkbox"/> PLC STOP <input type="checkbox"/> No transfer		Scaling factor: 1000

## C00783

Parameter   Name: <b>C00783   MCTRL_dwMotorVoltageAct</b>		Data type: UNSIGNED_32 Index: 23792 <sub>d</sub> = 5CF0 <sub>h</sub>
Internal motor control (MCTRL) signal		
<b>Display range (min. value   unit   max. value)</b>		
0	V	2000
<input checked="" type="checkbox"/> Read access <input type="checkbox"/> Write access <input type="checkbox"/> CINH <input type="checkbox"/> PLC STOP <input type="checkbox"/> No transfer		Scaling factor: 1

## C00784

Parameter   Name: <b>C00784   MCTRL_dnMotorFreqAct</b>		Data type: INTEGER_32 Index: 23791 <sub>d</sub> = 5CEF <sub>h</sub>
Internal motor control (MCTRL) signal		
<b>Display range (min. value   unit   max. value)</b>		
-800.0	Hz	800.0
<input checked="" type="checkbox"/> Read access <input type="checkbox"/> Write access <input type="checkbox"/> CINH <input type="checkbox"/> PLC STOP <input type="checkbox"/> No transfer		Scaling factor: 10

## C00786

Parameter   Name: <b>C00786   MCTRL_dnIxtLoad</b>		Data type: INTEGER_32 Index: 23789 <sub>d</sub> = 5CED <sub>h</sub>
Internal motor control (MCTRL) signal		
<b>Display range (min. value   unit   max. value)</b>		
-200.00	%	200.00
<input checked="" type="checkbox"/> Read access <input type="checkbox"/> Write access <input type="checkbox"/> CINH <input type="checkbox"/> PLC STOP <input type="checkbox"/> No transfer		Scaling factor: 100

## C00787

Parameter   Name: <b>C00787   MCTRL_dnFlyingSpeedAct</b>		Data type: INTEGER_32 Index: 23788 <sub>d</sub> = 5CEC <sub>h</sub>
Internal motor control (MCTRL) signal		
<b>Display range (min. value   unit   max. value)</b>		
-480000	rpm	480000
<input checked="" type="checkbox"/> Read access <input type="checkbox"/> Write access <input type="checkbox"/> CINH <input type="checkbox"/> PLC STOP <input type="checkbox"/> No transfer		Scaling factor: 1

## C00788

Parameter   Name: <b>C00788   MCTRL_dwMaxEffMotorTorque</b>			Data type: INTEGER_32 Index: 23787 <sub>d</sub> = 5CEB <sub>h</sub>
Internal motor control (MCTRL) signal			
<b>Display range (min. value   unit   max. value)</b>			
0.000	Nm	2147483.647	
<input checked="" type="checkbox"/> Read access <input type="checkbox"/> Write access <input type="checkbox"/> CINH <input type="checkbox"/> PLC STOP <input type="checkbox"/> No transfer			Scaling factor: 1000

## C00789

Parameter   Name: <b>C00789   MCTRL_dwMaxDeviceCurrent</b>			Data type: INTEGER_32 Index: 23786 <sub>d</sub> = 5CEA <sub>h</sub>
Internal motor control (MCTRL) signal			
<b>Display range (min. value   unit   max. value)</b>			
0.00	A	21474836.47	
<input checked="" type="checkbox"/> Read access <input type="checkbox"/> Write access <input type="checkbox"/> CINH <input type="checkbox"/> PLC STOP <input type="checkbox"/> No transfer			Scaling factor: 100

## C00790

Parameter   Name: <b>C00790   MCTRL_dnl2xtLoad</b>			Data type: INTEGER_32 Index: 23785 <sub>d</sub> = 5CE9 <sub>h</sub>
Internal motor control (MCTRL) signal			
<b>Display range (min. value   unit   max. value)</b>			
-200.00	%	200.00	
<input checked="" type="checkbox"/> Read access <input type="checkbox"/> Write access <input type="checkbox"/> CINH <input type="checkbox"/> PLC STOP <input type="checkbox"/> No transfer			Scaling factor: 100

## C00791

Parameter   Name: <b>C00791   MCTRL_dnDeltaMotorPos_p</b>			Data type: INTEGER_32 Index: 23784 <sub>d</sub> = 5CE8 <sub>h</sub>
Internal motor control (MCTRL) signal			
<b>Display range (min. value   unit   max. value)</b>			
-2147483647	Incr.	2147483647	
<input checked="" type="checkbox"/> Read access <input type="checkbox"/> Write access <input type="checkbox"/> CINH <input type="checkbox"/> PLC STOP <input type="checkbox"/> No transfer			Scaling factor: 1

## C00792

Parameter   Name: <b>C00792   MCTRL_dnOutputPosCtrlMotor_s</b>			Data type: INTEGER_32 Index: 23783 <sub>d</sub> = 5CE7 <sub>h</sub>
Internal motor control (MCTRL) signal			
<b>Display range (min. value   unit   max. value)</b>			
-200	%	200	
<input checked="" type="checkbox"/> Read access <input type="checkbox"/> Write access <input type="checkbox"/> CINH <input type="checkbox"/> PLC STOP <input type="checkbox"/> No transfer			Scaling factor: 1

## C00800

Parameter   Name: <b>C00800   MCTRL_dnPosSet</b>			Data type: UNSIGNED_32 Index: 23775 <sub>d</sub> = 5CDF <sub>h</sub>
Internal motor control (MCTRL) signal			
<b>Display range (min. value   unit   max. value)</b>			
0	Incr.	4294967295	
<b>Subcodes</b>			<b>Info</b>
C00800/1			LOW word
C00800/2			High word
<input checked="" type="checkbox"/> Read access <input type="checkbox"/> Write access <input type="checkbox"/> CINH <input type="checkbox"/> PLC STOP <input type="checkbox"/> No transfer			Scaling factor: 1

## C00802

Parameter   Name: <b>C00802   MCTRL_dnSpeedAdd</b>			Data type: INTEGER_32 Index: 23773 <sub>d</sub> = 5CDD <sub>h</sub>
Internal motor control (MCTRL) signal			
<b>Display range (min. value   unit   max. value)</b>			
-480000	rpm	480000	
<input checked="" type="checkbox"/> Read access <input type="checkbox"/> Write access <input type="checkbox"/> CINH <input type="checkbox"/> PLC STOP <input type="checkbox"/> No transfer			Scaling factor: 1

## C00803

Parameter   Name: <b>C00803   MCTRL_dnTorqueAdd</b>			Data type: INTEGER_32 Index: 23772 <sub>d</sub> = 5CDC <sub>h</sub>
Internal motor control (MCTRL) signal			
<b>Display range (min. value   unit   max. value)</b>			
-2147483.647	Nm	2147483.647	
<input checked="" type="checkbox"/> Read access <input type="checkbox"/> Write access <input type="checkbox"/> CINH <input type="checkbox"/> PLC STOP <input type="checkbox"/> No transfer			Scaling factor: 1000

## C00804

Parameter   Name: <b>C00804   MCTRL_dnAccelerationAdd</b>			Data type: INTEGER_32 Index: 23770 <sub>d</sub> = 5CDB <sub>h</sub>
Internal motor control (MCTRL) signal			
<b>Display range (min. value   unit   max. value)</b>			
-2147483.647	1/s <sup>2</sup>	2147483.647	
<input checked="" type="checkbox"/> Read access <input type="checkbox"/> Write access <input type="checkbox"/> CINH <input type="checkbox"/> PLC STOP <input type="checkbox"/> No transfer			Scaling factor: 1000

## C00805

Parameter   Name: <b>C00805   MCTRL_dnSpeedLowLimit</b>			Data type: INTEGER_32 Index: 23770 <sub>d</sub> = 5CDA <sub>h</sub>
Internal motor control (MCTRL) signal			
<b>Display range (min. value   unit   max. value)</b>			
-480000	rpm	480000	
<input checked="" type="checkbox"/> Read access <input type="checkbox"/> Write access <input type="checkbox"/> CINH <input type="checkbox"/> PLC STOP <input type="checkbox"/> No transfer			Scaling factor: 1

## C00806

Parameter   Name: <b>C00806   MCTRL_dnTorqueLowLimit</b>			Data type: INTEGER_32 Index: 23769 <sub>d</sub> = 5CD9 <sub>h</sub>
Internal motor control (MCTRL) signal			
<b>Display range (min. value   unit   max. value)</b>			
-21474836.47	Nm	21474836.47	
<input checked="" type="checkbox"/> Read access <input type="checkbox"/> Write access <input type="checkbox"/> CINH <input type="checkbox"/> PLC STOP <input type="checkbox"/> No transfer			Scaling factor: 100

## C00807

Parameter   Name: <b>C00807   MCTRL_dnTorqueHighLimit</b>			Data type: INTEGER_32 Index: 23768 <sub>d</sub> = 5CD8 <sub>h</sub>
Internal motor control (MCTRL) signal			
<b>Display range (min. value   unit   max. value)</b>			
-21474836.47	Nm	21474836.47	
<input checked="" type="checkbox"/> Read access <input type="checkbox"/> Write access <input type="checkbox"/> CINH <input type="checkbox"/> PLC STOP <input type="checkbox"/> No transfer			Scaling factor: 100

## C00808

Parameter   Name: <b>C00808   MCTRL_dnPosCtrlOutLimit</b>			Data type: INTEGER_32 Index: 23767 <sub>d</sub> = 5CD7 <sub>h</sub>
Internal motor control (MCTRL) signal			
<b>Display range (min. value   unit   max. value)</b>			
-480000	rpm	480000	
<input checked="" type="checkbox"/> Read access <input type="checkbox"/> Write access <input type="checkbox"/> CINH <input type="checkbox"/> PLC STOP <input type="checkbox"/> No transfer			Scaling factor: 1

## C00809

Parameter   Name: <b>C00809   MCTRL_dnTorqueCtrlAdapt</b>			Data type: INTEGER_32 Index: 23766 <sub>d</sub> = 5CD6 <sub>h</sub>
Internal motor control (MCTRL) signal			
<b>Display range (min. value   unit   max. value)</b>			
-200.00	%	200.00	
<input checked="" type="checkbox"/> Read access <input type="checkbox"/> Write access <input type="checkbox"/> CINH <input type="checkbox"/> PLC STOP <input type="checkbox"/> No transfer			Scaling factor: 100

## C00810

Parameter   Name: <b>C00810   MCTRL_dnSpeedCtrlAdapt</b>			Data type: INTEGER_32 Index: 23765 <sub>d</sub> = 5CD5 <sub>h</sub>
Internal motor control (MCTRL) signal			
<b>Display range (min. value   unit   max. value)</b>			
-200.00	%	200.00	
<input checked="" type="checkbox"/> Read access <input type="checkbox"/> Write access <input type="checkbox"/> CINH <input type="checkbox"/> PLC STOP <input type="checkbox"/> No transfer			Scaling factor: 100

## C00811

Parameter   Name: <b>C00811   MCTRL_dnPosCtrlAdapt</b>			Data type: INTEGER_32 Index: 23764 <sub>d</sub> = 5CD4 <sub>h</sub>
Internal motor control (MCTRL) signal			
<b>Display range (min. value   unit   max. value)</b>			
-200.00	%	200.00	
<input checked="" type="checkbox"/> Read access <input type="checkbox"/> Write access <input type="checkbox"/> CINH <input type="checkbox"/> PLC STOP <input type="checkbox"/> No transfer			Scaling factor: 100

## C00812

Parameter   Name: <b>C00812   MCTRL_dnMotorPosRefValue</b>			Data type: UNSIGNED_32 Index: 23763 <sub>d</sub> = 5CD3 <sub>h</sub>
Internal motor control (MCTRL) signal			
<b>Display range (min. value   unit   max. value)</b>			
0	Incr.	4294967295	
<b>Subcodes</b>		<b>Info</b>	
C00812/1		LOW word	
C00812/2		High word	
<input checked="" type="checkbox"/> Read access <input type="checkbox"/> Write access <input type="checkbox"/> CINH <input type="checkbox"/> PLC STOP <input type="checkbox"/> No transfer			Scaling factor: 1

## C00813

Parameter   Name: <b>C00813   MCTRL_dnLoadPosRefValue</b>			Data type: UNSIGNED_32 Index: 23762 <sub>d</sub> = 5CD2 <sub>h</sub>
Internal motor control (MCTRL) signal			
<b>Display range (min. value   unit   max. value)</b>			
0	Incr.	4294967295	
<b>Subcodes</b>		<b>Info</b>	
C00813/1		LOW word	
C00813/2		High word	
<input checked="" type="checkbox"/> Read access <input type="checkbox"/> Write access <input type="checkbox"/> CINH <input type="checkbox"/> PLC STOP <input type="checkbox"/> No transfer			Scaling factor: 1

## C00814

Parameter   Name: <b>C00814   MCTRL_dnBoost</b>			Data type: INTEGER_32 Index: 23761 <sub>d</sub> = 5CD1 <sub>h</sub>
Internal motor control (MCTRL) signal			
<b>Display range (min. value   unit   max. value)</b>			
-1000	V	1000	
<input checked="" type="checkbox"/> Read access <input type="checkbox"/> Write access <input type="checkbox"/> CINH <input type="checkbox"/> PLC STOP <input type="checkbox"/> No transfer			Scaling factor: 1

## C00815

Parameter   Name: <b>C00815   MCTRL_dnSpeedCtrlIntegrator</b>			Data type: INTEGER_32 Index: 23760 <sub>d</sub> = 5CD0 <sub>h</sub>
Internal motor control (MCTRL) signal			
<b>Display range (min. value   unit   max. value)</b>			
-2147483.647	Nm	2147483.647	
<input checked="" type="checkbox"/> Read access <input type="checkbox"/> Write access <input type="checkbox"/> CINH <input type="checkbox"/> PLC STOP <input type="checkbox"/> No transfer			Scaling factor: 1000

## C00816

Parameter   Name: <b>C00816   MCTRL_dnFieldWeak</b>			Data type: INTEGER_32 Index: 23759 <sub>d</sub> = 5CCF <sub>h</sub>
Internal motor control (MCTRL) signal			
<b>Display range (min. value   unit   max. value)</b>			
-200.00	%	200.00	
<input checked="" type="checkbox"/> Read access <input type="checkbox"/> Write access <input type="checkbox"/> CINH <input type="checkbox"/> PLC STOP <input type="checkbox"/> No transfer			Scaling factor: 100

## C00817

Parameter   Name: <b>C00817   MCTRL_dnSpeedSet_s</b>			Data type: INTEGER_32 Index: 23758 <sub>d</sub> = 5CCF <sub>h</sub>
Internal motor control (MCTRL) signal			
<b>Display range (min. value   unit   max. value)</b>			
-480000	rpm	480000	
<input checked="" type="checkbox"/> Read access <input type="checkbox"/> Write access <input type="checkbox"/> CINH <input type="checkbox"/> PLC STOP <input type="checkbox"/> No transfer			Scaling factor: 1

## C00818

Parameter   Name: <b>C00818   MCTRL_dnMvorAdapt</b>			Data type: INTEGER_32 Index: 23757 <sub>d</sub> = 5CCD <sub>h</sub>
From software version V1.5			
Internal motor control (MCTRL) signal			
<b>Display range (min. value   unit   max. value)</b>			
-200.00	%	200.00	
<input checked="" type="checkbox"/> Read access <input type="checkbox"/> Write access <input type="checkbox"/> CINH <input type="checkbox"/> PLC STOP <input type="checkbox"/> No transfer			Scaling factor: 100

## C00854

Parameter   Name: <b>C00854   ID status</b>			Data type: UNSIGNED_32 Index: 23721 <sub>d</sub> = 5CA9 <sub>h</sub>
From software version V3.0			
<b>Display range (min. value   unit   max. value)</b>			
0		100	
<input checked="" type="checkbox"/> Read access <input type="checkbox"/> Write access <input type="checkbox"/> CINH <input type="checkbox"/> PLC STOP <input type="checkbox"/> No transfer			Scaling factor: 1

## C00878

Parameter   Name: <b>C00878   Status DCTRL control input</b>			Data type: UNSIGNED_8 Index: 23697 <sub>d</sub> = 5C91 <sub>h</sub>
<b>Display range (min. value   unit   max. value)</b>			
0		1	
<b>Subcodes</b>		<b>Info</b>	
C00878/1		Status of control inputs	
C00878/...			
C00878/5			
<input checked="" type="checkbox"/> Read access <input type="checkbox"/> Write access <input type="checkbox"/> CINH <input type="checkbox"/> PLC STOP <input type="checkbox"/> No transfer			Scaling factor: 1



## C00909

Parameter   Name: <b>C00909   Speed limitation</b>		Data type: INTEGER_16 Index: 23666 <sub>d</sub> = 5C72 <sub>h</sub>
Speed limitation for speed setpoint <ul style="list-style-type: none"> <li>For the upper speed limit value only positive values are permissible (0.0 % ... 175.0 %).</li> <li>For the lower speed limit value only negative values are permissible (-175.0 % ... 0.0 %).</li> </ul>		
<b>Setting range (min. value   unit   max. value)</b>		
-175.0	%	175.0
<b>Subcodes</b>	<b>Lenze setting</b>	<b>Info</b>
C00909/1	175.0 %	Upper speed limit value
C00909/2	-175.0 %	Lower speed limit value
<input checked="" type="checkbox"/> Read access <input checked="" type="checkbox"/> Write access <input type="checkbox"/> CINH <input type="checkbox"/> PLC STOP <input type="checkbox"/> No transfer		Scaling factor: 10

## C00950

Parameter   Name: <b>C00950   VFC: V/f characteristic shape</b>		Data type: UNSIGNED_32 Index: 23625 <sub>d</sub> = 5C49 <sub>h</sub>
From software version V3.0		<a href="#">▶ V/f control</a>
<b>Selection list (Lenze setting printed in bold)</b>		
<b>0</b>	<b>Linear (V/f)</b>	
1	Quadratic (V/f <sup>2</sup> )	
2	Curve	
<input checked="" type="checkbox"/> Read access <input checked="" type="checkbox"/> Write access <input type="checkbox"/> CINH <input type="checkbox"/> PLC STOP <input type="checkbox"/> No transfer		Scaling factor: 1

## C00951

Parameter   Name: <b>C00951   VFC: V/f base frequency</b>		Data type: INTEGER_32 Index: 23624 <sub>d</sub> = 5C48 <sub>h</sub>
From software version V3.0		<a href="#">▶ V/f control</a>
<b>Setting range (min. value   unit   max. value)</b>		<b>Lenze setting</b>
1	Hz	5000
		<b>50 Hz</b>
<input checked="" type="checkbox"/> Read access <input checked="" type="checkbox"/> Write access <input type="checkbox"/> CINH <input type="checkbox"/> PLC STOP <input type="checkbox"/> No transfer		Scaling factor: 1

## C00952

Parameter   Name: C00952   VFC: Frequency interpol. point n			Data type: INTEGER_32 Index: 23623 <sub>d</sub> = 5C47 <sub>h</sub>
From software version V3.0			<a href="#">▶ V/f control</a>
Setting range (min. value   unit   max. value)			
-5000	Hz	5000	
Subcodes	Lenze setting	Info	
C00952/1	-50 Hz		
C00952/2	-40 Hz		
C00952/3	-30 Hz		
C00952/4	-20 Hz		
C00952/5	-10 Hz		
C00952/6	0 Hz		
C00952/7	10 Hz		
C00952/8	20 Hz		
C00952/9	30 Hz		
C00952/10	40 Hz		
C00952/11	50 Hz		
<input checked="" type="checkbox"/> Read access <input checked="" type="checkbox"/> Write access <input checked="" type="checkbox"/> CINH <input type="checkbox"/> PLC STOP <input type="checkbox"/> No transfer			Scaling factor: 1

## C00953

Parameter   Name: C00953   VFC: Voltage interpol. point n			Data type: INTEGER_32 Index: 23622 <sub>d</sub> = 5C46 <sub>h</sub>
From software version V3.0			<a href="#">▶ V/f control</a>
Setting range (min. value   unit   max. value)			
0.00	V	1000.00	
Subcodes	Lenze setting	Info	
C00953/1	400.00 V		
C00953/2	320.00 V		
C00953/3	240.00 V		
C00953/4	160.00 V		
C00953/5	80.00 V		
C00953/6	0.00 V		
C00953/7	80.00 V		
C00953/8	160.00 V		
C00953/9	240.00 V		
C00953/10	320.00 V		
C00953/11	400.00 V		
<input checked="" type="checkbox"/> Read access <input checked="" type="checkbox"/> Write access <input checked="" type="checkbox"/> CINH <input type="checkbox"/> PLC STOP <input type="checkbox"/> No transfer			Scaling factor: 100

## C00954

Parameter   Name:		Data type: UNSIGNED_32 Index: 23621 <sub>d</sub> = 5C45 <sub>h</sub>	
<b>C00954   VFC: Activat. interpol. point n</b>			
From software version V3.0		<a href="#">▶ V/f control</a>	
Selection list			
0	Off		
1	On		
Subcodes	Lenze setting	Info	
C00954/1	1: On		
C00954/2	1: On		
C00954/3	1: On		
C00954/4	1: On		
C00954/5	1: On		
C00954/6	1: On		
C00954/7	1: On		
C00954/8	1: On		
C00954/9	1: On		
C00954/10	1: On		
C00954/11	1: On		
<input checked="" type="checkbox"/> Read access		<input checked="" type="checkbox"/> Write access	
<input checked="" type="checkbox"/> CINH		<input type="checkbox"/> PLC STOP	
<input type="checkbox"/> No transfer		Scaling factor: 1	

## C00955

Parameter   Name:		Data type: UNSIGNED_32 Index: 23620 <sub>d</sub> = 5C44 <sub>h</sub>	
<b>C00955   VFC: Vmax reduction</b>			
From software version V3.0		<a href="#">▶ V/f control</a>	
Setting range (min. value   unit   max. value)		Lenze setting	
0	V	500	0 V
<input checked="" type="checkbox"/> Read access		<input checked="" type="checkbox"/> Write access	
<input type="checkbox"/> CINH		<input type="checkbox"/> PLC STOP	
<input type="checkbox"/> No transfer		Scaling factor: 1	

## C00957

Parameter   Name:		Data type: INTEGER_32 Index: 23618 <sub>d</sub> = 5C42 <sub>h</sub>	
<b>C00957   VFC: VVC current setpoint</b>			
From software version V3.0		<a href="#">▶ V/f control</a>	
Setting range (min. value   unit   max. value)		Lenze setting	
0.00	A	1500.00	0.00 A
<input checked="" type="checkbox"/> Read access		<input checked="" type="checkbox"/> Write access	
<input type="checkbox"/> CINH		<input type="checkbox"/> PLC STOP	
<input type="checkbox"/> No transfer		Scaling factor: 100	

## C00958

Parameter   Name: <b>C00958   VFC: VVC gain</b>			Data type: UNSIGNED_32 Index: 23617 <sub>d</sub> = 5C41 <sub>h</sub>
From software version V3.0			<a href="#">▶ V/f control</a>
Setting range (min. value   unit   max. value)		Lenze setting	
0.00	V/A	750.00	<b>0.00 V/A</b>
<input checked="" type="checkbox"/> Read access <input checked="" type="checkbox"/> Write access <input type="checkbox"/> CINH <input type="checkbox"/> PLC STOP <input type="checkbox"/> No transfer			Scaling factor: 100

## C00959

Parameter   Name: <b>C00959   VFC: VVC reset time</b>			Data type: UNSIGNED_32 Index: 23616 <sub>d</sub> = 5C40 <sub>h</sub>
From software version V3.0			<a href="#">▶ V/f control</a>
Setting range (min. value   unit   max. value)		Lenze setting	
0.01	ms	2000.00	<b>2000.00 ms</b>
<input checked="" type="checkbox"/> Read access <input checked="" type="checkbox"/> Write access <input type="checkbox"/> CINH <input type="checkbox"/> PLC STOP <input type="checkbox"/> No transfer			Scaling factor: 100

## C00960

Parameter   Name: <b>C00960   VFC: V/f voltage boost</b>			Data type: INTEGER_32 Index: 23615 <sub>d</sub> = 5C3F <sub>h</sub>
From software version V3.0			<a href="#">▶ V/f control</a>
Setting range (min. value   unit   max. value)		Lenze setting	
0	V	1000	<b>0 V</b>
<input checked="" type="checkbox"/> Read access <input checked="" type="checkbox"/> Write access <input type="checkbox"/> CINH <input type="checkbox"/> PLC STOP <input type="checkbox"/> No transfer			Scaling factor: 1

## C00961

Parameter   Name: <b>C00961   VFC: Load - cw/ccw-operation</b>			Data type: UNSIGNED_32 Index: 23614 <sub>d</sub> = 5C3E <sub>h</sub>
From software version V3.0			<a href="#">▶ V/f control</a>
Selection list (Lenze setting printed in bold)			
<b>0</b>	<b>CW: mot. / CCW: mot.</b>		
1	CW: mot. / CCW: regen.		
2	CW: regen. / CCW: mot.		
<input checked="" type="checkbox"/> Read access <input checked="" type="checkbox"/> Write access <input checked="" type="checkbox"/> CINH <input type="checkbox"/> PLC STOP <input type="checkbox"/> No transfer			Scaling factor: 1

## C00962

Parameter   Name: <b>C00962   VFC: Load adjustment</b>			Data type: UNSIGNED_32 Index: 23613 <sub>d</sub> = 5C3D <sub>h</sub>
From software version V3.0			<a href="#">▶ V/f control</a>
Setting range (min. value   unit   max. value)		Lenze setting	
0.00	%	200.00	<b>20.00 %</b>
<input checked="" type="checkbox"/> Read access <input checked="" type="checkbox"/> Write access <input type="checkbox"/> CINH <input type="checkbox"/> PLC STOP <input type="checkbox"/> No transfer			Scaling factor: 100

## C00963

Parameter   Name: <b>C00963   VFC: Gain - I<sub>max</sub> controller</b>			Data type: UNSIGNED_32 Index: 23612 <sub>d</sub> = 5C3C <sub>h</sub>
From software version V3.0			<a href="#">▶ V/f control</a>
Setting range (min. value   unit   max. value)		Lenze setting	
0.000	Hz/A	1000.000	<b>0.001 Hz/A</b>
<input checked="" type="checkbox"/> Read access <input checked="" type="checkbox"/> Write access <input type="checkbox"/> CINH <input type="checkbox"/> PLC STOP <input type="checkbox"/> No transfer			Scaling factor: 1000

## C00964

Parameter   Name: <b>C00964   VFC: Reset time - I<sub>max</sub> contr.</b>			Data type: UNSIGNED_32 Index: 23611 <sub>d</sub> = 5C3B <sub>h</sub>
From software version V3.0			<a href="#">▶ V/f control</a>
Setting range (min. value   unit   max. value)		Lenze setting	
1.0	ms	2000.0	<b>100.0 ms</b>
<input checked="" type="checkbox"/> Read access <input checked="" type="checkbox"/> Write access <input type="checkbox"/> CINH <input type="checkbox"/> PLC STOP <input type="checkbox"/> No transfer			Scaling factor: 10

## C00965

Parameter   Name: <b>C00965   VFC: Gain - slip compensation</b>			Data type: INTEGER_32 Index: 23610 <sub>d</sub> = 5C3A <sub>h</sub>
From software version V3.0			<a href="#">▶ V/f control</a>
Setting range (min. value   unit   max. value)		Lenze setting	
-200.00	%	200.00	<b>0.00 %</b>
<input checked="" type="checkbox"/> Read access <input checked="" type="checkbox"/> Write access <input type="checkbox"/> CINH <input type="checkbox"/> PLC STOP <input type="checkbox"/> No transfer			Scaling factor: 100

## C00966

Parameter   Name: <b>C00966   VFC: Time const. slip comp.</b>			Data type: UNSIGNED_32 Index: 23609 <sub>d</sub> = 5C39 <sub>h</sub>
From software version V3.0			<a href="#">▶ V/f control</a>
Setting range (min. value   unit   max. value)		Lenze setting	
1	ms	6000	<b>2000 ms</b>
<input checked="" type="checkbox"/> Read access <input checked="" type="checkbox"/> Write access <input type="checkbox"/> CINH <input type="checkbox"/> PLC STOP <input type="checkbox"/> No transfer			Scaling factor: 1

## C00967

Parameter   Name: <b>C00967   VFC: Gain - oscillation damping</b>			Data type: INTEGER_32 Index: 23608 <sub>d</sub> = 5C38 <sub>h</sub>
From software version V3.0			<a href="#">▶ V/f control</a>
Setting range (min. value   unit   max. value)		Lenze setting	
-100	%	100	<b>20 %</b>
<input checked="" type="checkbox"/> Read access <input checked="" type="checkbox"/> Write access <input type="checkbox"/> CINH <input type="checkbox"/> PLC STOP <input type="checkbox"/> No transfer			Scaling factor: 1

## C00968

Parameter   Name: <b>C00968   VFC: Time const. - oscill. damp.</b>			Data type: INTEGER_32 Index: 23607 <sub>d</sub> = 5C37 <sub>h</sub>
From software version V3.0			<a href="#">▶ V/f control</a>
Setting range (min. value   unit   max. value)		Lenze setting	
1	ms	600	5 ms
<input checked="" type="checkbox"/> Read access <input checked="" type="checkbox"/> Write access <input type="checkbox"/> CINH <input type="checkbox"/> PLC STOP <input type="checkbox"/> No transfer			Scaling factor: 1

## C00969

Parameter   Name: <b>C00969   VFC: Limitation - oscill. damp.</b>			Data type: INTEGER_32 Index: 23606 <sub>d</sub> = 5C36 <sub>h</sub>
From software version V3.0			<a href="#">▶ V/f control</a>
Setting range (min. value   unit   max. value)		Lenze setting	
0.1	Hz	20.0	0.2 Hz
<input checked="" type="checkbox"/> Read access <input checked="" type="checkbox"/> Write access <input type="checkbox"/> CINH <input type="checkbox"/> PLC STOP <input type="checkbox"/> No transfer			Scaling factor: 10

## C00970

Parameter   Name: <b>C00970   VFC: ramp-end frequ. - oscill. damp.</b>			Data type: INTEGER_32 Index: 23605 <sub>d</sub> = 5C35 <sub>h</sub>
From software version V5.0			<a href="#">▶ V/f control</a>
Setting range (min. value   unit   max. value)		Lenze setting	
0	%	100	0 %
<input checked="" type="checkbox"/> Read access <input checked="" type="checkbox"/> Write access <input type="checkbox"/> CINH <input type="checkbox"/> PLC STOP <input type="checkbox"/> No transfer			Scaling factor: 1

## C00971

Parameter   Name: <b>C00971   VFC: Influence - speed controller</b>			Data type: UNSIGNED_32 Index: 23604 <sub>d</sub> = 5C34 <sub>h</sub>
From software version V3.0			<a href="#">▶ V/f control</a>
Setting range (min. value   unit   max. value)		Lenze setting	
0.00	%	100.00	10.00 %
<input checked="" type="checkbox"/> Read access <input checked="" type="checkbox"/> Write access <input type="checkbox"/> CINH <input type="checkbox"/> PLC STOP <input type="checkbox"/> No transfer			Scaling factor: 100

## C00972

Parameter   Name: <b>C00972   VFC: Gain - speed controller</b>			Data type: UNSIGNED_32 Index: 23603 <sub>d</sub> = 5C33 <sub>h</sub>
From software version V3.0			<a href="#">▶ V/f control</a>
Setting range (min. value   unit   max. value)		Lenze setting	
0.000	Hz/rpm	1000.000	0.000 Hz/rpm
<input checked="" type="checkbox"/> Read access <input checked="" type="checkbox"/> Write access <input type="checkbox"/> CINH <input type="checkbox"/> PLC STOP <input type="checkbox"/> No transfer			Scaling factor: 1000

## C00973

Parameter   Name: <b>C00973   VFC: Reset time - speed contr.</b>			Data type: UNSIGNED_32 Index: 23602 <sub>d</sub> = 5C32 <sub>h</sub>
From software version V3.0			<a href="#">▶ V/f control</a>
Setting range (min. value   unit   max. value)		Lenze setting	
1.0	ms	6000.0	<b>6000.0 ms</b>
<input checked="" type="checkbox"/> Read access <input checked="" type="checkbox"/> Write access <input type="checkbox"/> CINH <input type="checkbox"/> PLC STOP <input type="checkbox"/> No transfer			Scaling factor: 10

## C00974

Parameter   Name: <b>C00974   DC brake: Current</b>			Data type: INTEGER_32 Index: 23601 <sub>d</sub> = 5C31 <sub>h</sub>
From software version V3.0			<a href="#">▶ DC-injection braking</a>
Setting range (min. value   unit   max. value)		Lenze setting	
0.00	A	500.00	<b>0.00 A</b>
<input checked="" type="checkbox"/> Read access <input checked="" type="checkbox"/> Write access <input type="checkbox"/> CINH <input type="checkbox"/> PLC STOP <input type="checkbox"/> No transfer			Scaling factor: 100

## C00975

Parameter   Name: <b>C00975   DC brake: Current for quick stop</b>			Data type: INTEGER_32 Index: 23600 <sub>d</sub> = 5C30 <sub>h</sub>
From software version V3.0			<a href="#">▶ DC-injection braking</a>
Setting range (min. value   unit   max. value)		Lenze setting	
0.00	A	500.00	<b>0.00 A</b>
<input checked="" type="checkbox"/> Read access <input checked="" type="checkbox"/> Write access <input type="checkbox"/> CINH <input type="checkbox"/> PLC STOP <input type="checkbox"/> No transfer			Scaling factor: 100

## C00976

Parameter   Name: <b>C00976   DC brake: Activat. by quick stop</b>			Data type: UNSIGNED_32 Index: 23599 <sub>d</sub> = 5C2F <sub>h</sub>
From software version V3.0			<a href="#">▶ DC-injection braking</a>
Selection list (Lenze setting printed in bold)			
0	<b>Off</b>		
1	On		
<input checked="" type="checkbox"/> Read access <input checked="" type="checkbox"/> Write access <input type="checkbox"/> CINH <input type="checkbox"/> PLC STOP <input type="checkbox"/> No transfer			Scaling factor: 1

## C00977

Parameter   Name: <b>C00977   Min. inh-time aft. overvolt</b>			Data type: UNSIGNED_32 Index: 23598 <sub>d</sub> = 5C2E <sub>h</sub>
From software version V3.0			<a href="#">▶ V/f control</a>
Setting range (min. value   unit   max. value)		Lenze setting	
1	ms	10000	<b>500 ms</b>
<input checked="" type="checkbox"/> Read access <input checked="" type="checkbox"/> Write access <input type="checkbox"/> CINH <input type="checkbox"/> PLC STOP <input type="checkbox"/> No transfer			Scaling factor: 1

## C00980

Parameter   Name: <b>C00980   VFC: Override point of field weakening</b>		Data type: INTEGER_32 Index: 23595 <sub>d</sub> = 5C2B <sub>h</sub>
From software version V8.0		
Offset of the override point for field weakening		
<ul style="list-style-type: none"> <li>In the VFCplus operating mode the pull-out protection function or the maximally permissible current in the field weakening range can be adapted.</li> </ul>		
<b>Setting range</b> (min. value   unit   max. value)		<b>Lenze setting</b>
-500	Hz	500
		<b>0 Hz</b>
<input checked="" type="checkbox"/> Read access <input checked="" type="checkbox"/> Write access <input type="checkbox"/> CINH <input type="checkbox"/> PLC STOP <input type="checkbox"/> No transfer		Scaling factor: 1

## C00985

Parameter   Name: <b>C00985   SLVC: Gain of field current controller</b>		Data type: UNSIGNED_32 Index: 23590 <sub>d</sub> = 5C26 <sub>h</sub>
From software version V3.0		
▶ <a href="#">Sensorless vector control</a>		
<b>Setting range</b> (min. value   unit   max. value)		<b>Lenze setting</b>
0.00		21474836.47
		<b>0.00</b>
<input checked="" type="checkbox"/> Read access <input checked="" type="checkbox"/> Write access <input type="checkbox"/> CINH <input type="checkbox"/> PLC STOP <input type="checkbox"/> No transfer		Scaling factor: 100

## C00986

Parameter   Name: <b>C00986   SLVC: Gain of cross current controller</b>		Data type: UNSIGNED_32 Index: 23589 <sub>d</sub> = 5C25 <sub>h</sub>
From software version V3.0		
▶ <a href="#">Sensorless vector control</a>		
<b>Setting range</b> (min. value   unit   max. value)		<b>Lenze setting</b>
0.00		21474836.47
		<b>0.00</b>
<input checked="" type="checkbox"/> Read access <input checked="" type="checkbox"/> Write access <input type="checkbox"/> CINH <input type="checkbox"/> PLC STOP <input type="checkbox"/> No transfer		Scaling factor: 100

## C00987

Parameter   Name: <b>C00987   SLVC: Gain - torque controller</b>		Data type: UNSIGNED_32 Index: 23588 <sub>d</sub> = 5C24 <sub>h</sub>
From software version V3.0		
▶ <a href="#">Sensorless vector control</a>		
<b>Setting range</b> (min. value   unit   max. value)		<b>Lenze setting</b>
0.0000	Hz/A	1000.0000
		<b>0.5000 Hz/A</b>
<input checked="" type="checkbox"/> Read access <input checked="" type="checkbox"/> Write access <input type="checkbox"/> CINH <input type="checkbox"/> PLC STOP <input type="checkbox"/> No transfer		Scaling factor: 10000

## C00988

Parameter   Name: <b>C00988   SLVC: Reset time - torque contr.</b>		Data type: UNSIGNED_32 Index: 23587 <sub>d</sub> = 5C23 <sub>h</sub>
From software version V3.0		
▶ <a href="#">Sensorless vector control</a>		
<b>Setting range</b> (min. value   unit   max. value)		<b>Lenze setting</b>
0.01	ms	2000.00
		<b>10.00 ms</b>
<input checked="" type="checkbox"/> Read access <input checked="" type="checkbox"/> Write access <input type="checkbox"/> CINH <input type="checkbox"/> PLC STOP <input type="checkbox"/> No transfer		Scaling factor: 100



## C00989

Parameter   Name: <b>C00989   SLVC: Time const.- Para. adj.</b>		Data type: UNSIGNED_32 Index: 23586 <sub>d</sub> = 5C22 <sub>h</sub>
From software version V3.0		
<a href="#">▶ Sensorless vector control</a>		
Setting range (min. value   unit   max. value)		
0	ms	20000
Subcodes	Lenze setting	Info
C00989/1	20000 ms	SLVC: Time const.- Para.Rs adj.
C00989/2	20000 ms	SLVC: Time const.- Para.Lh adj.
<input checked="" type="checkbox"/> Read access <input checked="" type="checkbox"/> Write access <input type="checkbox"/> CINH <input type="checkbox"/> PLC STOP <input type="checkbox"/> No transfer		Scaling factor: 1

## C00990

Parameter   Name: <b>C00990   Flying restart: Activation</b>		Data type: UNSIGNED_32 Index: 23585 <sub>d</sub> = 5C21 <sub>h</sub>
From software version V3.0		
<b>Note!</b> Only deactivate the flying restart for the V/f control or sensorless vector control if it is ensured that the drive is always at standstill in the case of controller enable!		
<a href="#">▶ Flying restart fct.</a>		
Selection list (Lenze setting printed in bold)		
0	<b>Off</b>	
1	On	
<input checked="" type="checkbox"/> Read access <input checked="" type="checkbox"/> Write access <input type="checkbox"/> CINH <input type="checkbox"/> PLC STOP <input type="checkbox"/> No transfer		Scaling factor: 1

## C00991

Parameter   Name: <b>C00991   Flying restart: Current</b>		Data type: INTEGER_32 Index: 23584 <sub>d</sub> = 5C20 <sub>h</sub>
From software version V3.0		
<a href="#">▶ Flying restart fct.</a>		
Setting range (min. value   unit   max. value)		Lenze setting
0	%	100
		<b>15 %</b>
<input checked="" type="checkbox"/> Read access <input checked="" type="checkbox"/> Write access <input type="checkbox"/> CINH <input type="checkbox"/> PLC STOP <input type="checkbox"/> No transfer		Scaling factor: 1

## C00992

Parameter   Name: <b>C00992   Flying restart: Start frequency</b>		Data type: INTEGER_32 Index: 23583 <sub>d</sub> = 5C1F <sub>h</sub>
From software version V3.0		
<a href="#">▶ Flying restart fct.</a>		
Setting range (min. value   unit   max. value)		Lenze setting
-600.0	Hz	600.0
		<b>20.0 Hz</b>
<input checked="" type="checkbox"/> Read access <input checked="" type="checkbox"/> Write access <input type="checkbox"/> CINH <input type="checkbox"/> PLC STOP <input type="checkbox"/> No transfer		Scaling factor: 10

## C00993

Parameter   Name: <b>C00993   Flying restart: Integration time</b>			Data type: UNSIGNED_32 Index: 23582 <sub>d</sub> = 5C1E <sub>h</sub>
From software version V3.0			<a href="#">▶ Flying restart fct.</a>
Setting range (min. value   unit   max. value)		Lenze setting	
1	ms	6000	<b>60 ms</b>
<input checked="" type="checkbox"/> Read access <input checked="" type="checkbox"/> Write access <input type="checkbox"/> CINH <input type="checkbox"/> PLC STOP <input type="checkbox"/> No transfer			Scaling factor: 1

## C00994

Parameter   Name: <b>C00994   Flying restart: Min. deviation</b>			Data type: UNSIGNED_32 Index: 23581 <sub>d</sub> = 5C1D <sub>h</sub>
From software version V3.0			<a href="#">▶ Flying restart fct.</a>
Setting range (min. value   unit   max. value)		Lenze setting	
0.00	°	90.00	<b>5.00 °</b>
<input checked="" type="checkbox"/> Read access <input checked="" type="checkbox"/> Write access <input type="checkbox"/> CINH <input type="checkbox"/> PLC STOP <input type="checkbox"/> No transfer			Scaling factor: 100

## C00995

Parameter   Name: <b>C00995   Flying restart: Delay time</b>			Data type: UNSIGNED_32 Index: 23580 <sub>d</sub> = 5C1C <sub>h</sub>
From software version V3.0			<a href="#">▶ Flying restart fct.</a>
Setting range (min. value   unit   max. value)		Lenze setting	
0	ms	10000	<b>0 ms</b>
<input checked="" type="checkbox"/> Read access <input checked="" type="checkbox"/> Write access <input type="checkbox"/> CINH <input type="checkbox"/> PLC STOP <input type="checkbox"/> No transfer			Scaling factor: 1

## C00998

Parameter   Name: <b>C00998   VFC: Frequency setpoint</b>			Data type: INTEGER_32 Index: 23577 <sub>d</sub> = 5C19 <sub>h</sub>
From software version V3.0			<a href="#">▶ V/f control</a>
Display range (min. value   unit   max. value)			
-800.0	Hz	800.0	
<input checked="" type="checkbox"/> Read access <input type="checkbox"/> Write access <input type="checkbox"/> CINH <input type="checkbox"/> PLC STOP <input type="checkbox"/> No transfer			Scaling factor: 10

## C01120

Parameter   Name: <b>C01120   Sync source</b>		Data type: UNSIGNED_8 Index: 23455 <sub>d</sub> = 5B9F <sub>h</sub>
Selection of the source for the synchronisation signals. <ul style="list-style-type: none"> <li>The drive can only be synchronised by one source.</li> </ul> <b>Note:</b> Set the selection "2: CAN module" for the communication module CANopen (E94AYCCA). ▶ <a href="#">"CAN on board" system bus: sync telegram</a>		
Selection list (Lenze setting printed in bold)		
0	<b>Off</b>	
1	CAN on board	
2	CAN module	
4	Module in MXI1	
5	Module in MXI2	
6	Digital input 1	
7	Digital input 2	
8	Digital input 3	
9	Digital input 4	
10	Digital input 5	
11	Digital input 6	
12	Digital input 7	
13	Digital input 8	
<input checked="" type="checkbox"/> Read access <input checked="" type="checkbox"/> Write access <input type="checkbox"/> CINH <input type="checkbox"/> PLC STOP <input type="checkbox"/> No transfer             Scaling factor: 1		

## C01121

Parameter   Name: <b>C01121   Sync cycle time</b>		Data type: UNSIGNED_32 Index: 23454 <sub>d</sub> = 5B9E <sub>h</sub>
Time interval at which the phase control loop (PLL) in the controller expects the synchronisation signals. <ul style="list-style-type: none"> <li>The time interval set must correspond to the cycle of the synchronisation source.</li> </ul> <b>Note:</b> For synchronisation via the system bus (CANopen), only integer multiples of 1000 µs should be set. Example: For the system bus, the interval between two synchronisation signals is set to 2 ms. If the system bus is to be used as the synchronisation source, a synchronisation cycle of 2000 µs must be set in C01121. ▶ <a href="#">"CAN on board" system bus: sync telegram</a>		
Setting range (min. value   unit   max. value)		Lenze setting
250	µs	20000
		<b>1000 µs</b>
<input checked="" type="checkbox"/> Read access <input checked="" type="checkbox"/> Write access <input type="checkbox"/> CINH <input type="checkbox"/> PLC STOP <input type="checkbox"/> No transfer             Scaling factor: 1		

## C01122

Parameter   Name: <b>C01122   Sync phase position</b>		Data type: UNSIGNED_32 Index: 23453 <sub>d</sub> = 5B9D <sub>h</sub>	
<p>The phase position defines the zero point of time for the application relating to the synchronisation signal (bus cycle). Since PDO processing is integrated in the system part of the application, the instant of the PDO acceptance also changes if the phase position is changed.</p> <ul style="list-style-type: none"> <li>• If 0 is set, the application is started together with the synchronisation signal.</li> <li>• If a value &gt; 0 is set, the application starts by the set time interval before the synchronisation signal arrives (the phase position acts negatively).</li> </ul> <p>Example: If the phase position is set to 400 µs, the system part of the application starts 400 µs before the synchronisation signal arrives.</p> <p>From software version V3.0: The effect of the sync phase position can be affected by the application cycle set in <a href="#">C01130</a>. For the Lenze setting of <a href="#">C01130</a> the behaviour remains as before.</p> <p style="text-align: right;">▶ <a href="#">"CAN on board" system bus: sync telegram</a></p>			
<b>Setting range (min. value   unit   max. value)</b>		<b>Lenze setting</b>	
0	µs	64000	<b>400 µs</b>
<input checked="" type="checkbox"/> Read access <input checked="" type="checkbox"/> Write access <input type="checkbox"/> CINH <input type="checkbox"/> PLC STOP <input type="checkbox"/> No transfer		Scaling factor: 1	

## C01123

Parameter   Name: <b>C01123   Sync tolerance</b>		Data type: UNSIGNED_32 Index: 23452 <sub>d</sub> = 5B9C <sub>h</sub>	
<p>Time slot for monitoring the synchronisation signal via the <b>LS_SyncInput</b> system block</p> <ul style="list-style-type: none"> <li>• If the last synchronisation signal has been within this time slot around the expected value, the <b>SYNC_bSynclnsideWindow</b> output of the <b>LS_SyncInput</b> system block is set to TRUE.</li> <li>• This setting does not affect the synchronisation process.</li> </ul> <p style="text-align: right;">▶ <a href="#">"CAN on board" system bus: sync telegram</a></p>			
<b>Setting range (min. value   unit   max. value)</b>		<b>Lenze setting</b>	
0	µs	1000	<b>0 µs</b>
<input checked="" type="checkbox"/> Read access <input checked="" type="checkbox"/> Write access <input type="checkbox"/> CINH <input type="checkbox"/> PLC STOP <input type="checkbox"/> No transfer		Scaling factor: 1	

C01124

Parameter   Name: <b>C01124   Sync-PLL increment</b>		Data type: UNSIGNED_8 Index: 23451 <sub>d</sub> = 5B9B <sub>h</sub>
<p>When the cycle times of the synchronisation signal and the phase control loop (PLL) differ, this setting defines the increment to be used to readjust the phase control loop.</p> <ul style="list-style-type: none"> <li>• If the system bus (CANopen) is used as the synchronisation source, the recommended value is 109 ns.</li> </ul> <p style="text-align: right;">▶ <a href="#">"CAN on board" system bus: sync telegram</a></p>		
<b>Selection list (Lenze setting printed in bold)</b>		
1	7 ns	
2	15 ns	
3	23 ns	
4	31 ns	
5	39 ns	
6	46 ns	
7	54 ns	
8	62 ns	
9	70 ns	
10	78 ns	
11	85 ns	
12	93 ns	
13	101 ns	
14	<b>109 ns</b>	
15	117 ns	
16	125 ns	
17	132 ns	
18	140 ns	
19	148 ns	
20	156 ns	
21	164 ns	
22	171 ns	
23	179 ns	
24	187 ns	
25	195 ns	
26	203 ns	
27	210 ns	
<input checked="" type="checkbox"/> Read access <input checked="" type="checkbox"/> Write access <input type="checkbox"/> CINH <input type="checkbox"/> PLC STOP <input type="checkbox"/> No transfer		Scaling factor: 1

C01125

Parameter   Name: <b>C01125   Service code</b>		Data type: UNSIGNED_32 Index: 23450 <sub>d</sub> = 5B9A <sub>h</sub>
<b>This code is for device-internal use only and must not be written to by the user!</b>		

C01126

Parameter   Name: <b>C01126   Service code</b>		Data type: UNSIGNED_32 Index: 23449 <sub>d</sub> = 5B99 <sub>h</sub>
<b>This code is for device-internal use only and must not be written to by the user!</b>		

# 14 Parameter reference

## 14.2 Parameter list | C01127

### C01127

Parameter   Name: <b>C01127   Service code</b>	Data type: UNSIGNED_32 Index: 23448 <sub>d</sub> = 5B98 <sub>h</sub>
<b>This code is for device-internal use only and must not be written to by the user!</b>	

### C01128

Parameter   Name: <b>C01128   Service code</b>	Data type: UNSIGNED_32 Index: 23447 <sub>d</sub> = 5B97 <sub>h</sub>
<b>This code is for device-internal use only and must not be written to by the user!</b>	

### C01129

Parameter   Name: <b>C01129   Service code</b>	Data type: UNSIGNED_32 Index: 23446 <sub>d</sub> = 5B96 <sub>h</sub>
<b>This code is for device-internal use only and must not be written to by the user!</b>	

### C01130

Parameter   Name: <b>C01130   CAN SYNC application cycle</b>	Data type: UNSIGNED_16 Index: 23445 <sub>d</sub> = 5B95 <sub>h</sub>	
<p><a href="#">From software version V3.0</a></p> <p>This parameter affects the effect of the sync phase position (<a href="#">C01122</a>) regarding the instant of acceptance of the synchronous PDOs in the application and the instant of transmission of the synchronous PDOs on the system bus (CANopen).</p> <ul style="list-style-type: none"> <li>The resulting PDO delay can be calculated with the following formula taking into account an internal processing time of 150 µs: PDO delay = (<a href="#">C01121</a> - <a href="#">C01122</a> + 150 µs) modulo C01130</li> <li>For the Lenze setting, the behaviour remains as before, the sync phase position (<a href="#">C01122</a>) is always calculated modulo 1000.</li> <li>The set value is automatically rounded down to multiples of 1000 µs.</li> </ul> <p>► <a href="#">Effect of C01130 on the sync phase position</a></p> <p><b>Note:</b> Setting the application cycle to a higher value than the sync cycle time (<a href="#">C01121</a>) results in undefined behaviour. The same applies if the value set for the sync phase position (<a href="#">C01122</a>) is higher than the sync cycle time (<a href="#">C01121</a>). In this case, the drive usually cannot send synchronous PDOs on the system bus anymore.</p> <p style="text-align: right;">► <a href="#">"CAN on board" system bus: sync telegram</a></p>		
<b>Setting range</b> (min. value   unit   max. value)		
1000	µs	65000
		<b>Lenze setting</b>
		<b>1000 µs</b>
<input checked="" type="checkbox"/> Read access <input checked="" type="checkbox"/> Write access <input type="checkbox"/> CINH <input type="checkbox"/> PLC STOP <input type="checkbox"/> No transfer		Scaling factor: 1

### C01190

Parameter   Name: <b>C01190   Motor thermal sensor</b>	Data type: UNSIGNED_32 Index: 23385 <sub>d</sub> = 5B59 <sub>h</sub>	
► <a href="#">Motor temperature monitoring</a>		
<b>Selection list</b> (Lenze setting printed in bold)		
<b>0</b>	KTY83-110	Lenze standard KTY83-110 (MDSKX, MCS06)
1	Spec. characteristic	Characteristic defined via <a href="#">C01191</a> and <a href="#">C01192</a>
2	KTY83-110 + 2 x PTC	Lenze standard KTY83-110 + 2 x PTC 150°C (MCS09-MCS19)
5	Pt1000	
6	Pt1000 + 2 x PTC	
<input checked="" type="checkbox"/> Read access <input checked="" type="checkbox"/> Write access <input type="checkbox"/> CINH <input type="checkbox"/> PLC STOP <input type="checkbox"/> No transfer		Scaling factor: 1

## C01191

Parameter   Name: <b>C01191   Spec. charact.: temperature</b>		Data type: UNSIGNED_32 Index: 23384 <sub>d</sub> = 5B58 <sub>h</sub>
The spec. thermal sensor characteristic is selected through the setting <a href="#">C01190="1"</a> ▶ <a href="#">Motor temperature monitoring</a>		
Setting range (min. value   unit   max. value)		
0	°C	255
Subcodes	Lenze setting	Info
C01191/1	25 °C	Value 1 for spec. thermal sensor characteristic
C01191/2	150 °C	Value 2 for spec. thermal sensor characteristic
<input checked="" type="checkbox"/> Read access <input checked="" type="checkbox"/> Write access <input type="checkbox"/> CINH <input type="checkbox"/> PLC STOP <input type="checkbox"/> No transfer		Scaling factor: 1

## C01192

Parameter   Name: <b>C01192   Spec. characteristic: resistance</b>		Data type: UNSIGNED_32 Index: 23383 <sub>d</sub> = 5B57 <sub>h</sub>
The spec. thermal sensor characteristic is selected through the setting <a href="#">C01190="1"</a> ▶ <a href="#">Motor temperature monitoring</a>		
Setting range (min. value   unit   max. value)		
0	Ohm	30000
Subcodes	Lenze setting	Info
C01192/1	1000 Ohm	Value 1 for spec. thermal sensor characteristic
C01192/2	2225 ohms	Value 2 for spec. thermal sensor characteristic
<input checked="" type="checkbox"/> Read access <input checked="" type="checkbox"/> Write access <input type="checkbox"/> CINH <input type="checkbox"/> PLC STOP <input type="checkbox"/> No transfer		Scaling factor: 1

## C01193

Parameter   Name: <b>C01193   Motor temp. feedback system</b>		Data type: UNSIGNED_16 Index: 23382 <sub>d</sub> = 5B56 <sub>h</sub>
Selection of feedback system for motor temperature detection. ▶ <a href="#">Motor temperature monitoring</a>		
Selection list (Lenze setting printed in bold)		
<b>0</b>	<b>Speed feedback</b>	
1	X7 (Input Resolver)	
2	X8 (Input Encoder)	
3	Reserved	
4	Reserved	
5	X7 and X8 parallel	
<input checked="" type="checkbox"/> Read access <input checked="" type="checkbox"/> Write access <input checked="" type="checkbox"/> CINH <input type="checkbox"/> PLC STOP <input type="checkbox"/> No transfer		Scaling factor: 1

## C01194

Parameter   Name: <b>C01194   Motor operating temperature</b>		Data type: INTEGER_32 Index: 23381 <sub>d</sub> = 5B55 <sub>h</sub>
Setting range (min. value   unit   max. value)		Lenze setting
1	°C	200 <b>140 °C</b>
<input checked="" type="checkbox"/> Read access <input checked="" type="checkbox"/> Write access <input type="checkbox"/> CINH <input type="checkbox"/> PLC STOP <input type="checkbox"/> No transfer		Scaling factor: 1

## C01195

Parameter   Name: <b>C01195   Influence winding I<sup>2</sup>xt mon.</b>		Data type: UNSIGNED_32 Index: 23380 <sub>d</sub> = 5B54 <sub>h</sub>	
I <sup>2</sup> xt motor monitoring: Influence of the winding temperature			
<ul style="list-style-type: none"> <li>By setting "0 %", the time constant for the winding is not considered and the thermal model is only calculated with the time constant set for the housing/laminated core.</li> </ul>			
<a href="#">▶ I<sup>2</sup>xt motor monitoring</a>			
<b>Setting range (min. value   unit   max. value)</b>		<b>Lenze setting</b>	
0	%	100	0 %
<input checked="" type="checkbox"/> Read access <input checked="" type="checkbox"/> Write access <input type="checkbox"/> CINH <input type="checkbox"/> PLC STOP <input type="checkbox"/> No transfer		Scaling factor: 1	

## C01196

Parameter   Name: <b>C01196   S1 torque characteristic I<sup>2</sup>xt mon.</b>		Data type: UNSIGNED_32 Index: 23379 <sub>d</sub> = 5B53 <sub>h</sub>	
<ul style="list-style-type: none"> <li>By selecting a characteristic, the permissible motor current is evaluated depending on speed for calculating the thermal motor utilisation.</li> </ul>			
<a href="#">▶ I<sup>2</sup>xt motor monitoring</a>			
<b>Setting range (min. value   unit   max. value)</b>			
0	%	600	
<b>Subcodes</b>	<b>Lenze setting</b>	<b>Info</b>	
C01196/1	0 %	S1 torque characteristic n1/nn	
C01196/2	100 %	S1 torque characteristic I1/In	
C01196/3	0 %	S1 torque characteristic n2/nn	
C01196/4	100 %	S1 torque characteristic I2/In	
C01196/5	100 %	S1 torque characteristic n3/nn	
C01196/6	100 %	S1 torque characteristic I3/In	
C01196/7	100 %	S1 torque characteristic n4/nn	
C01196/8	100 %	S1 torque characteristic I4/In	
<input checked="" type="checkbox"/> Read access <input checked="" type="checkbox"/> Write access <input type="checkbox"/> CINH <input type="checkbox"/> PLC STOP <input type="checkbox"/> No transfer		Scaling factor: 1	

## C01197

Parameter   Name: <b>C01197   Starting value I<sup>2</sup>xt monitoring</b>		Data type: UNSIGNED_32 Index: 23378 <sub>d</sub> = 5B52 <sub>h</sub>	
From software version V11.0			
<a href="#">▶ I<sup>2</sup>xt motor monitoring</a>			
<b>Setting range (min. value   unit   max. value)</b>		<b>Lenze setting</b>	
0	%	200	0 %
<input checked="" type="checkbox"/> Read access <input checked="" type="checkbox"/> Write access <input type="checkbox"/> CINH <input type="checkbox"/> PLC STOP <input type="checkbox"/> No transfer		Scaling factor: 1	

## C01198

Parameter   Name: <b>C01198   Async. motor: Stall protection</b>		Data type: UNSIGNED_32 Index: 23377 <sub>d</sub> = 5B51 <sub>h</sub>	
<b>Setting range (min. value   unit   max. value)</b>		<b>Lenze setting</b>	
0	%	100	0 %
<input checked="" type="checkbox"/> Read access <input checked="" type="checkbox"/> Write access <input type="checkbox"/> CINH <input type="checkbox"/> PLC STOP <input type="checkbox"/> No transfer		Scaling factor: 1	



## C01199

Parameter   Name: <b>C01199   Enhanced Power</b>		Data type: UNSIGNED_32 Index: 23376 <sub>d</sub> = 5B50 <sub>h</sub>
From software version V3.0		
<b>Stop!</b> During operation with increased continuous power, the max. permissible ambient temperature is reduced to 40 °C. The overload current must be reduced. An overload current of 180 % for 10 s is no longer permissible during operation with increased continuous power.		
<a href="#">▶ Operation with increased continuous power</a>		
<b>Selection list</b> (Lenze setting printed in bold)		
<b>0</b>	<b>Enhanced Power off</b>	
1	Enhanced Power Mode 1 on	
2	Enhanced Power Mode 2 on	
<input checked="" type="checkbox"/> Read access <input checked="" type="checkbox"/> Write access <input checked="" type="checkbox"/> CINH <input type="checkbox"/> PLC STOP <input type="checkbox"/> No transfer		Scaling factor: 1

## C01200

Parameter   Name: <b>C01200   Dual motor temperature</b>		Data type: INTEGER_32 Index: 23375 <sub>d</sub> = 5B4F <sub>h</sub>
From software version V7.0		
<a href="#">▶ Motor temperature monitoring</a> <a href="#">▶ Motor temperature monitoring of a second motor</a>		
<b>Display range</b> (min. value   unit   max. value)		
-200	°C	200
<b>Subcodes</b>		<b>Info</b>
C01200/1		Motor temperature via X7
C01200/2		Motor temperature via X8
<input checked="" type="checkbox"/> Read access <input type="checkbox"/> Write access <input type="checkbox"/> CINH <input type="checkbox"/> PLC STOP <input type="checkbox"/> No transfer		Scaling factor: 1

## C01201

Parameter   Name: <b>C01201   Delay time for fan start</b>		Data type: UNSIGNED_32 Index: 23374 <sub>d</sub> = 5B4E <sub>h</sub>
From software version V8.0		
<b>Selection list</b> (Lenze setting printed in bold)		
<b>0</b>	<b>Via power section serial no.</b>	
1	500 ms	
2	1000 ms	
3	1500 ms	
4	2000 ms	
5	2500 ms	
6	3000 ms	
7	3500 ms	
8	4000 ms	
9	4500 ms	
10	5000 ms	
<input checked="" type="checkbox"/> Read access <input checked="" type="checkbox"/> Write access <input type="checkbox"/> CINH <input type="checkbox"/> PLC STOP <input type="checkbox"/> No transfer		Scaling factor: 1

## C01203

Parameter   Name: <b>C01203   Counter: Brake chopper overload</b>		Data type: UNSIGNED_16 Index: 23372 <sub>d</sub> = 5B4C <sub>h</sub>
Display range (min. value   unit   max. value)		
0		65535
<input checked="" type="checkbox"/> Read access <input type="checkbox"/> Write access <input type="checkbox"/> CINH <input type="checkbox"/> PLC STOP <input type="checkbox"/> No transfer		Scaling factor: 1

## C01204

Parameter   Name: <b>C01204   Counter: lxt overload</b>		Data type: UNSIGNED_16 Index: 23371 <sub>d</sub> = 5B4B <sub>h</sub>
Display range (min. value   unit   max. value)		
0		65535
<input checked="" type="checkbox"/> Read access <input type="checkbox"/> Write access <input type="checkbox"/> CINH <input type="checkbox"/> PLC STOP <input type="checkbox"/> No transfer		Scaling factor: 1

## C01205

Parameter   Name: <b>C01205   Counter: DC bus overvoltage</b>		Data type: UNSIGNED_16 Index: 23370 <sub>d</sub> = 5B4A <sub>h</sub>
Display range (min. value   unit   max. value)		
0		65535
<input checked="" type="checkbox"/> Read access <input type="checkbox"/> Write access <input type="checkbox"/> CINH <input type="checkbox"/> PLC STOP <input type="checkbox"/> No transfer		Scaling factor: 1

## C01206

Parameter   Name: <b>C01206   Counter: Mains switching</b>		Data type: UNSIGNED_16 Index: 23369 <sub>d</sub> = 5B49 <sub>h</sub>
Display range (min. value   unit   max. value)		
0		65535
<input checked="" type="checkbox"/> Read access <input type="checkbox"/> Write access <input type="checkbox"/> CINH <input type="checkbox"/> PLC STOP <input type="checkbox"/> No transfer		Scaling factor: 1

## C01208

Parameter   Name: <b>C01208   Counter: Heatsink overtemp.</b>		Data type: UNSIGNED_16 Index: 23367 <sub>d</sub> = 5B47 <sub>h</sub>
Display range (min. value   unit   max. value)		
0		65535
<input checked="" type="checkbox"/> Read access <input type="checkbox"/> Write access <input type="checkbox"/> CINH <input type="checkbox"/> PLC STOP <input type="checkbox"/> No transfer		Scaling factor: 1

## C01209

Parameter   Name: <b>C01209   Counter: Housing overtemp.</b>		Data type: UNSIGNED_16 Index: 23366 <sub>d</sub> = 5B46 <sub>h</sub>
Display range (min. value   unit   max. value)		
0		65535
<input checked="" type="checkbox"/> Read access <input type="checkbox"/> Write access <input type="checkbox"/> CINH <input type="checkbox"/> PLC STOP <input type="checkbox"/> No transfer		Scaling factor: 1

# 14 Parameter reference

## 14.2 Parameter list | C01210

### C01210

Parameter   Name: <b>C01210   Counter: Internal</b>		Data type: UNSIGNED_8 Index: 23365 <sub>d</sub> = 5B45 <sub>h</sub>
From software version V8.0		
Display range (min. value   unit   max. value)		
0		255
<input checked="" type="checkbox"/> Read access <input type="checkbox"/> Write access <input type="checkbox"/> CINH <input type="checkbox"/> PLC STOP <input type="checkbox"/> No transfer		Scaling factor: 1

### C01211

Parameter   Name: <b>C01211   Service code</b>		Data type: UNSIGNED_32 Index: 23364 <sub>d</sub> = 5B44 <sub>h</sub>
<b>This code is for device-internal use only and must not be written to by the user!</b>		

### C01212

Parameter   Name: <b>C01212   Counter: Power section overload</b>		Data type: UNSIGNED_16 Index: 23363 <sub>d</sub> = 5B43 <sub>h</sub>
Display range (min. value   unit   max. value)		
0		65535
<input checked="" type="checkbox"/> Read access <input type="checkbox"/> Write access <input type="checkbox"/> CINH <input type="checkbox"/> PLC STOP <input type="checkbox"/> No transfer		Scaling factor: 1

### C01213

Parameter   Name: <b>C01213   Service code DataFlash</b>		Data type: UNSIGNED_32 Index: 23362 <sub>d</sub> = 5B42 <sub>h</sub>
<b>This code is for device-internal use only and must not be written to by the user!</b>		

### C01214

Parameter   Name: <b>C01214   Internal clock</b>		Data type: VISIBLE_STRING Index: 23361 <sub>d</sub> = 5B41 <sub>h</sub>
Display of the system time of the controller in the format "dd/mm/yyyy hh:mm:ss" <ul style="list-style-type: none"><li>• Time and date are set via <a href="#">C01215</a>.</li></ul>		
If the MM440 memory module with real-time clock is plugged into the controller, the internal clock is adjusted to the real-time clock every time the mains is switched on and every 24 hours at 0:00 o'clock. <ul style="list-style-type: none"><li>• The daily adjustment is executed on a low-priority level. This is why it may take some seconds until the adjusted time is displayed.</li><li>• During the adjustment process, status information of the real-time clock is also queried and entered into the logbook.</li></ul>		
<b>Note:</b> If a memory module without real-time clock is plugged into the controller, the internal clock is initialised with "01.01.1970 00:00:00" every time the mains is switched on.		
<input checked="" type="checkbox"/> Read access <input type="checkbox"/> Write access <input type="checkbox"/> CINH <input type="checkbox"/> PLC-STOP <input type="checkbox"/> No transfer		Scaling factor: 1 Character length: 21

## C01215

Parameter   Name: <b>C01215   Set time and date</b>		Data type: UNSIGNED_16 Index: 23360 <sub>d</sub> = 5B40 <sub>h</sub>
From software version V1.5		
Setting of the system time of the controller displayed in <a href="#">C01214</a> .		
<ul style="list-style-type: none"> <li>• If the MM440 memory module with real-time clock is plugged into the controller, the real-time clock is set simultaneously.</li> </ul>		
Set time and date.		
<ul style="list-style-type: none"> <li>• Before writing to a subcode for the first time, the current time information according to the internal clock is displayed in the subcodes.</li> <li>• When a value has been written into a subcode, the displays in the subcodes freeze to the last values.</li> <li>• The new system time set is only accepted after a value has been written into each subcode at least once.</li> <li>• After the new system time has been accepted, the display in the subcodes is updated according to the internal clock.</li> </ul>		
<b>Note:</b>		
If a memory module without real-time clock is plugged into the controller, the internal clock is initialised with "01.01.1970 00:00:00" every time the mains is switched on.		
<b>Setting range (min. value   unit   max. value)</b>		
0		65535
<b>Subcodes</b>	<b>Lenze setting</b>	<b>Info</b>
C01215/1	0	Seconds
C01215/2	0	Minutes
C01215/3	0	Hours
C01215/4	1	Day
C01215/5	1	Month
C01215/6	1970	Year
<input checked="" type="checkbox"/> Read access <input checked="" type="checkbox"/> Write access <input type="checkbox"/> CINH <input type="checkbox"/> PLC STOP <input checked="" type="checkbox"/> No transfer		Scaling factor: 1

## C01217

Parameter   Name: <b>C01217   Service code</b>	Data type: VISIBLE_STRING Index: 23358 <sub>d</sub> = 5B3E <sub>h</sub>
<b>This code is for device-internal use only and must not be written to by the user!</b>	

## C01218

Parameter   Name: <b>C01218   Service code</b>	Data type: UNSIGNED_32 Index: 23357 <sub>d</sub> = 5B3D <sub>h</sub>
<b>This code is for device-internal use only and must not be written to by the user!</b>	

## C01220

Parameter   Name: <b>C01220   MEC history: RAM address</b>	Data type: UNSIGNED_32 Index: 23354 <sub>d</sub> = 5B3B <sub>h</sub>
<b>This code is for device-internal use only and must not be written to by the user!</b>	

## C01221

Parameter   Name: <b>C01221   MEC history: RAM value</b>	Data type: UNSIGNED_32 Index: 23354 <sub>d</sub> = 5B3A <sub>h</sub>
<b>This code is for device-internal use only and must not be written to by the user!</b>	

**C01222**

Parameter   Name: <b>C01222   MEC history: Flash value</b>	Data type: UNSIGNED_32 Index: 23353 <sub>d</sub> = 5B39 <sub>h</sub>
<b>This code is for device-internal use only and must not be written to by the user!</b>	

**C01223**

Parameter   Name: <b>C01223   MEC history: Error number</b>	Data type: UNSIGNED_32 Index: 23352 <sub>d</sub> = 5B38 <sub>h</sub>
<b>This code is for device-internal use only and must not be written to by the user!</b>	

**C01230**

Parameter   Name: <b>C01230   Resp. to comm. task overflow</b>	Data type: UNSIGNED_8 Index: 23345 <sub>d</sub> = 5B31 <sub>h</sub>
From software version <a href="#">V7.0</a>	
<b>Selection list</b> (Lenze setting printed in bold)	
1	<b>Error</b>
2	Fault
3	Quick stop by trouble
4	Warning locked
5	Warning
6	Information
0	No response
<input checked="" type="checkbox"/> Read access <input checked="" type="checkbox"/> Write access <input type="checkbox"/> CINH <input type="checkbox"/> PLC STOP <input type="checkbox"/> No transfer                   Scaling factor: 1	

**C01501**

Parameter   Name: <b>C01501   Resp. to comm. error with MXI1</b>	Data type: UNSIGNED_32 Index: 23074 <sub>d</sub> = 5A22 <sub>h</sub>
Response to a communication error between an "intelligent" module in slot 1 and the standard device	
<b>Selection list</b> (Lenze setting printed in bold)	
0	<b>No response</b>
1	Error
3	Quick stop by trouble
4	Warning locked
5	Warning
<input checked="" type="checkbox"/> Read access <input checked="" type="checkbox"/> Write access <input type="checkbox"/> CINH <input type="checkbox"/> PLC STOP <input type="checkbox"/> No transfer                   Scaling factor: 1	

**C01502**

Parameter   Name: <b>C01502   Resp. to comm. error with MXI2</b>		Data type: UNSIGNED_32 Index: 23073 <sub>d</sub> = 5A21 <sub>h</sub>
Response to a communication error between an "intelligent" module in module slot 2 and the standard device		
<b>Selection list</b> (Lenze setting printed in bold)		
0	<b>No response</b>	
1	Error	
3	Quick stop by trouble	
4	Warning locked	
5	Warning	
<input checked="" type="checkbox"/> Read access <input checked="" type="checkbox"/> Write access <input type="checkbox"/> CINH <input type="checkbox"/> PLC STOP <input type="checkbox"/> No transfer		Scaling factor: 1

**C01510**

Parameter   Name: <b>C01510   Ethernet IP address client x</b>		Data type: VISIBLE_STRING Index: 23065 <sub>d</sub> = 5A19 <sub>h</sub>
Display of the three possible server channels		
<ul style="list-style-type: none"> <li>• If a client is connected via one of these server channels, the IP address and the port of the client will be indicated in the form of "xxx.xxx.xxx.xxx : yyyy".</li> <li>• If no client is connected via the server channel, "----:----:----:----" will be indicated.</li> </ul>		
<b>Subcodes</b>		<b>Info</b>
C01510/1	Server channel 1 ... 3	
C01510/...		
C01510/3		
<input checked="" type="checkbox"/> Read access <input type="checkbox"/> Write access <input type="checkbox"/> CINH <input type="checkbox"/> PLC STOP <input type="checkbox"/> No transfer		Scaling factor: 1 Character length: 24

**C01511**

Parameter   Name: <b>C01511   Ethernet status client x</b>		Data type: UNSIGNED_8 Index: 23064 <sub>d</sub> = 5A18 <sub>h</sub>
Status of the three possible server channels		
<b>Selection list</b> (read only)		
0	Not connected	
1	Connected	
2	Stop,	
3	Unknown status	
<b>Subcodes</b>		<b>Info</b>
C01511/1	State of server channels 1 ... 3	
C01511/...		
C01511/3		
<input checked="" type="checkbox"/> Read access <input type="checkbox"/> Write access <input type="checkbox"/> CINH <input type="checkbox"/> PLC STOP <input type="checkbox"/> No transfer		Scaling factor: 1

## C01700

Parameter   Name: <b>C01700   Energy: Mode inform.</b>		Data type: UNSIGNED_8 Index: 22875 <sub>d</sub> = 595B <sub>h</sub>
From software version V9.0		
<b>Display range (min. value   unit   max. value)</b>		
0		255
<b>Subcodes</b>	<b>Info</b>	
C01700/1	Energy: Max. modes	
C01700/2	Energy: Curr. mode	
<input checked="" type="checkbox"/> Read access <input type="checkbox"/> Write access <input type="checkbox"/> CINH <input type="checkbox"/> PLC STOP <input type="checkbox"/> No transfer		Scaling factor: 1

## C01701

Parameter   Name: <b>C01701   Energy: toff min</b>		Data type: UNSIGNED_32 Index: 22874 <sub>d</sub> = 595A <sub>h</sub>
From software version V9.0		
<b>Setting range (min. value   unit   max. value)</b>		
0	ms	4294967295
<b>Subcodes</b>	<b>Lenze setting</b>	<b>Info</b>
C01701/1	0 ms	Energy mode 1: toff min
<input checked="" type="checkbox"/> Read access <input checked="" type="checkbox"/> Write access <input type="checkbox"/> CINH <input type="checkbox"/> PLC STOP <input type="checkbox"/> No transfer		Scaling factor: 1

## C01702

Parameter   Name: <b>C01702   Energy: toff</b>		Data type: UNSIGNED_32 Index: 22873 <sub>d</sub> = 5959 <sub>h</sub>
From software version V9.0		
<b>Setting range (min. value   unit   max. value)</b>		
0	ms	4294967295
<b>Subcodes</b>	<b>Lenze setting</b>	<b>Info</b>
C01702/1	0 ms	Energy mode 1: toff
<input checked="" type="checkbox"/> Read access <input checked="" type="checkbox"/> Write access <input type="checkbox"/> CINH <input type="checkbox"/> PLC STOP <input type="checkbox"/> No transfer		Scaling factor: 1

## C01703

Parameter   Name: <b>C01703   Energy: ton</b>		Data type: UNSIGNED_32 Index: 22872 <sub>d</sub> = 5958 <sub>h</sub>
From software version V9.0		
<b>Setting range (min. value   unit   max. value)</b>		
0	ms	4294967295
<b>Subcodes</b>	<b>Lenze setting</b>	<b>Info</b>
C01703/1	0 ms	Energy mode 1: ton
<input checked="" type="checkbox"/> Read access <input checked="" type="checkbox"/> Write access <input type="checkbox"/> CINH <input type="checkbox"/> PLC STOP <input type="checkbox"/> No transfer		Scaling factor: 1

C01704

Parameter   Name: <b>C01704   Energy: Comp. to be switched off</b>		Data type: BITFIELD_32 Index: 22871 <sub>d</sub> = 5957 <sub>h</sub>
<a href="#">From software version V9.0</a>		
Setting range		
0x00000000		0xFFFFFFFF
Value is bit-coded: ( <input checked="" type="checkbox"/> = bit set)		
Bit 0 <input checked="" type="checkbox"/> IMP		
Bit 1 <input type="checkbox"/> Reserved		
Bit 2 <input type="checkbox"/> Reserved		
Bit 3 <input type="checkbox"/> Reserved		
Bit 4 <input type="checkbox"/> Reserved		
Bit 5 <input type="checkbox"/> Reserved		
Bit 6 <input type="checkbox"/> Reserved		
Bit 7 <input type="checkbox"/> Reserved		
Bit 8 <input type="checkbox"/> Reserved		
Bit 9 <input type="checkbox"/> Reserved		
Bit 10 <input type="checkbox"/> Reserved		
Bit 11 <input type="checkbox"/> Reserved		
Bit 12 <input type="checkbox"/> Reserved		
Bit 13 <input type="checkbox"/> Reserved		
Bit 14 <input type="checkbox"/> Reserved		
Bit 15 <input type="checkbox"/> Reserved		
Bit 16 <input type="checkbox"/> Reserved		
Bit 17 <input type="checkbox"/> Reserved		
Bit 18 <input type="checkbox"/> Reserved		
Bit 19 <input type="checkbox"/> Reserved		
Bit 20 <input type="checkbox"/> Reserved		
Bit 21 <input type="checkbox"/> Reserved		
Bit 22 <input type="checkbox"/> Reserved		
Bit 23 <input type="checkbox"/> Reserved		
Bit 24 <input type="checkbox"/> Reserved		
Bit 25 <input type="checkbox"/> Reserved		
Bit 26 <input type="checkbox"/> Reserved		
Bit 27 <input type="checkbox"/> Reserved		
Bit 28 <input type="checkbox"/> Reserved		
Bit 29 <input type="checkbox"/> Reserved		
Bit 30 <input type="checkbox"/> Reserved		
Bit 31 <input type="checkbox"/> Reserved		
Subcodes	Lenze setting	Info
C01704/1	0x00000000	Energy m. 1: Comp. to be sw. off
<input checked="" type="checkbox"/> Read access <input checked="" type="checkbox"/> Write access <input type="checkbox"/> CINH <input type="checkbox"/> PLC STOP <input type="checkbox"/> No transfer		Scaling factor: 1



C01705

Parameter   Name: <b>C01705   Energy: Power input</b>		Data type: UNSIGNED_32 Index: 22870 <sub>d</sub> = 5956 <sub>h</sub>
From software version V9.0		
<b>Setting range</b> (min. value   unit   max. value)		
0	W	4294967295
<b>Subcodes</b>	<b>Lenze setting</b>	<b>Info</b>
C01705/1	0 W	Energy m. 1: Power input
<input checked="" type="checkbox"/> Read access <input checked="" type="checkbox"/> Write access <input type="checkbox"/> CINH <input type="checkbox"/> PLC STOP <input type="checkbox"/> No transfer		Scaling factor: 1

C01902

Parameter   Name: <b>C01902   Diagnostics X6: Max. baud rate</b>		Data type: UNSIGNED_32 Index: 22673 <sub>d</sub> = 5891 <sub>h</sub>
Maximum permissible baud rate of the standard device after determination of the baud rate at the diagnostic interface X6		
<ul style="list-style-type: none"> <li>• Communication starts with the default standard device baud rate of 19200 baud.</li> </ul>		
<b>Selection list</b> (Lenze setting printed in bold)		
9600	9600 baud	
19200	19.200 baud	
38400	38.400 baud	
57600	57.600 baud	
115200	115.200 baud	
230400	230.400 baud	
375000	375.000 baud	
750000	750.000 baud	
1500000	1.500.000 baud	
<b>3000000</b>	<b>3.000.000 baud</b>	
<input checked="" type="checkbox"/> Read access <input checked="" type="checkbox"/> Write access <input type="checkbox"/> CINH <input type="checkbox"/> PLC STOP <input type="checkbox"/> No transfer		Scaling factor: 1

C01903

Parameter   Name: <b>C01903   Diagnostics X6: Change baud rate</b>		Data type: UNSIGNED_32 Index: 22672 <sub>d</sub> = 5890 <sub>h</sub>
New determination of the baud rate at the diagnostic interface X6		
<b>Selection list</b> (Lenze setting printed in bold)		
1	Set a higher baud rate	
<b>0</b>	<b>Ignore changes</b>	
<input checked="" type="checkbox"/> Read access <input checked="" type="checkbox"/> Write access <input type="checkbox"/> CINH <input type="checkbox"/> PLC STOP <input checked="" type="checkbox"/> No transfer		Scaling factor: 1

C01905

Parameter   Name: <b>C01905   Diagnostics X6: Curr. baud rate</b>		Data type: UNSIGNED_32 Index: 22670 <sub>d</sub> = 588E <sub>h</sub>
Current baud rate at diagnostics interface X6		
<b>Display range</b> (min. value   unit   max. value)		
0		3000000
<input checked="" type="checkbox"/> Read access <input type="checkbox"/> Write access <input type="checkbox"/> CINH <input type="checkbox"/> PLC STOP <input type="checkbox"/> No transfer		Scaling factor: 1

# 14 Parameter reference

## 14.2 Parameter list | C02104

### C02104

Parameter   Name: <b>C02104   Program auto-start</b>		Data type: UNSIGNED_32 Index: 22471 <sub>d</sub> = 57C7 <sub>h</sub>
<p><b>⚠ Danger!</b> The controller enable generated by the application via a connection of the terminal 28 (RFR) with one of the digital outputs <i>DIGOUT_bOut(x)</i> is not permissible if the following functions are active: "Auto-start after mains ON" (<a href="#">C00142</a> = "1") and "Program auto-start after mains switching" (<a href="#">C02104</a> = "1") <b>If this is not observed, the controller can start automatically after mains connection!</b></p> <p style="text-align: right;"><a href="#">▶ Automatic restart after mains connection</a> <a href="#">▶ Activate application</a></p>		
<b>Selection list</b> (Lenze setting printed in bold)		
0	Off	
1	<b>Autom. after mains connection</b>	
<input checked="" type="checkbox"/> Read access <input checked="" type="checkbox"/> Write access <input type="checkbox"/> CINH <input type="checkbox"/> PLC STOP <input type="checkbox"/> No transfer		Scaling factor: 1

### C02108

Parameter   Name: <b>C02108   Program status</b>		Data type: UNSIGNED_8 Index: 22467 <sub>d</sub> = 57C3 <sub>h</sub>
<b>Selection list</b> (read only)		
1	Program stopped	
0	Program is running	
2	Program stopped at breakpoint	
<input checked="" type="checkbox"/> Read access <input type="checkbox"/> Write access <input type="checkbox"/> CINH <input type="checkbox"/> PLC STOP <input type="checkbox"/> No transfer		Scaling factor: 1

### C02109

Parameter   Name: <b>C02109   Program runtime</b>		Data type: UNSIGNED_16 Index: 22466 <sub>d</sub> = 57C2 <sub>h</sub>
<b>Display range</b> (min. value   unit   max. value)		
0	µs	65535
<input checked="" type="checkbox"/> Read access <input type="checkbox"/> Write access <input type="checkbox"/> CINH <input type="checkbox"/> PLC STOP <input type="checkbox"/> No transfer		Scaling factor: 1

### C02110

Parameter   Name: <b>C02110   User code memory load</b>		Data type: UNSIGNED_32 Index: 22465 <sub>d</sub> = 57C1 <sub>h</sub>
<a href="#">From software version V2.0 onwards</a>		
<b>Display range</b> (min. value   unit   max. value)		
0	%	100
<input checked="" type="checkbox"/> Read access <input type="checkbox"/> Write access <input type="checkbox"/> CINH <input type="checkbox"/> PLC STOP <input type="checkbox"/> No transfer		Scaling factor: 1

## C02111

Parameter   Name: <b>C02111   Resp. to task overflow</b>		Data type: UNSIGNED_8 Index: 22464 <sub>d</sub> = 57C0 <sub>h</sub>
From software version V5.0		
Response to an application or user task overflow.		
<b>Selection list</b> (Lenze setting printed in bold)		
<b>1</b>	<b>Error</b>	
<b>3</b>	<b>Quick stop by trouble</b>	
<input checked="" type="checkbox"/> Read access <input checked="" type="checkbox"/> Write access <input type="checkbox"/> CINH <input type="checkbox"/> PLC STOP <input type="checkbox"/> No transfer		Scaling factor: 1

## C02112

Parameter   Name: <b>C02112   B. code: Read non-vol. memory</b>		Data type: UNSIGNED_32 Index: 22463 <sub>d</sub> = 57BF <sub>h</sub>
From software version V9.0		
<b>Display range</b> (min. value   unit   max. value)		
0	%	1000
<input checked="" type="checkbox"/> Read access <input type="checkbox"/> Write access <input type="checkbox"/> CINH <input type="checkbox"/> PLC STOP <input type="checkbox"/> No transfer		Scaling factor: 1

## C02113

Parameter   Name: <b>C02113   Program name</b>		Data type: VISIBLE_STRING Index: 22462 <sub>d</sub> = 57BE <sub>h</sub>
<input checked="" type="checkbox"/> Read access <input type="checkbox"/> Write access <input type="checkbox"/> CINH <input type="checkbox"/> PLC STOP <input type="checkbox"/> No transfer		Scaling factor: 1 Character length: 32

## C02119

Parameter   Name: <b>C02119   Active target ID</b>		Data type: UNSIGNED_32 Index: 22456 <sub>d</sub> = 57B8 <sub>h</sub>
From software version V9.0		
<b>Display range</b> (min. value   unit   max. value)		
0		4294967295
<input checked="" type="checkbox"/> Read access <input type="checkbox"/> Write access <input type="checkbox"/> CINH <input type="checkbox"/> PLC STOP <input type="checkbox"/> No transfer		Scaling factor: 1

## C02121

Parameter   Name: <b>C02121   Runtime ApplicationTask</b>		Data type: UNSIGNED_32 Index: 22454 <sub>d</sub> = 57B6 <sub>h</sub>
▶ <a href="#">Runtime measurement</a>		
<b>Display range</b> (min. value   unit   max. value)		
0	μs	3600000000
<b>Subcodes</b>		<b>Info</b>
C02121/1		Curr. runtime ApplicationTask
C02121/2		Max. runtime ApplicationTask
<input checked="" type="checkbox"/> Read access <input type="checkbox"/> Write access <input type="checkbox"/> CINH <input type="checkbox"/> PLC STOP <input type="checkbox"/> No transfer		Scaling factor: 1

## C02122

Parameter   Name: <b>C02122   Runtime UserTask</b>		Data type: UNSIGNED_32 Index: 22453 <sub>d</sub> = 57B5 <sub>h</sub>	
<a href="#">▶ Runtime measurement</a>			
<b>Display range (min. value   unit   max. value)</b>			
0	μs	3600000000	
<b>Subcodes</b>		<b>Info</b>	
C02122/1		Curr. runtime UserTask	
C02122/2		Max. runtime UserTask	
<input checked="" type="checkbox"/> Read access		<input type="checkbox"/> Write access	
<input type="checkbox"/> CINH		<input type="checkbox"/> PLC STOP	
<input type="checkbox"/> No transfer		Scaling factor: 1	

## C02123

Parameter   Name: <b>C02123   Runtime IdleTask</b>		Data type: UNSIGNED_32 Index: 22452 <sub>d</sub> = 57B4 <sub>h</sub>	
<a href="#">▶ Runtime measurement</a>			
<b>Display range (min. value   unit   max. value)</b>			
0	μs	3600000000	
<b>Subcodes</b>		<b>Info</b>	
C02123/1		Curr. runtime IdleTask	
C02123/2		Max. runtime IdleTask	
<input checked="" type="checkbox"/> Read access		<input type="checkbox"/> Write access	
<input type="checkbox"/> CINH		<input type="checkbox"/> PLC STOP	
<input type="checkbox"/> No transfer		Scaling factor: 1	

## C02520

Parameter   Name: <b>C02520   Gearbox factor numerator: Motor</b>		Data type: INTEGER_32 Index: 22054 <sub>d</sub> = 5627 <sub>h</sub>	
<a href="#">▶ Drive interface</a>			
<b>Setting range (min. value   unit   max. value)</b>		<b>Lenze setting</b>	
1		2147483647	1
<input checked="" type="checkbox"/> Read access		<input checked="" type="checkbox"/> Write access	
<input checked="" type="checkbox"/> CINH		<input type="checkbox"/> PLC STOP	
<input type="checkbox"/> No transfer		Scaling factor: 1	

## C02521

Parameter   Name: <b>C02521   Gearbox factor denom.: Motor</b>		Data type: INTEGER_32 Index: 22054 <sub>d</sub> = 5626 <sub>h</sub>	
<a href="#">▶ Drive interface</a>			
<b>Setting range (min. value   unit   max. value)</b>		<b>Lenze setting</b>	
1		2147483647	1
<input checked="" type="checkbox"/> Read access		<input checked="" type="checkbox"/> Write access	
<input checked="" type="checkbox"/> CINH		<input type="checkbox"/> PLC STOP	
<input type="checkbox"/> No transfer		Scaling factor: 1	

## C02522

Parameter   Name: <b>C02522   Gearbox factor num.: Pos. enc.</b>		Data type: INTEGER_32 Index: 22053 <sub>d</sub> = 5625 <sub>h</sub>	
<a href="#">▶ Drive interface</a>			
<b>Setting range (min. value   unit   max. value)</b>		<b>Lenze setting</b>	
1		2147483647	1
<input checked="" type="checkbox"/> Read access		<input checked="" type="checkbox"/> Write access	
<input checked="" type="checkbox"/> CINH		<input type="checkbox"/> PLC STOP	
<input type="checkbox"/> No transfer		Scaling factor: 1	

## C02523

Parameter   Name: <b>C02523   Gearbox fac. denom.: Pos. enc.</b>		Data type: INTEGER_32 Index: 22052 <sub>d</sub> = 5624 <sub>h</sub>	
<a href="#">▶ Drive interface</a>			
Setting range (min. value   unit   max. value)		Lenze setting	
1		2147483647	<b>1</b>
<input checked="" type="checkbox"/> Read access <input checked="" type="checkbox"/> Write access <input checked="" type="checkbox"/> CINH <input type="checkbox"/> PLC STOP <input type="checkbox"/> No transfer		Scaling factor: 1	

## C02524

Parameter   Name: <b>C02524   Feed constant</b>		Data type: UNSIGNED_32 Index: 22051 <sub>d</sub> = 5623 <sub>h</sub>	
<a href="#">▶ Drive interface</a>			
Setting range (min. value   unit   max. value)		Lenze setting	
0.0001	Unit/rev.	214748.3647	<b>360.0000 Unit/rev.</b>
<input checked="" type="checkbox"/> Read access <input checked="" type="checkbox"/> Write access <input checked="" type="checkbox"/> CINH <input type="checkbox"/> PLC STOP <input type="checkbox"/> No transfer		Scaling factor: 10000	

## C02525

Parameter   Name: <b>C02525   Unit</b>		Data type: UNSIGNED_32 Index: 22050 <sub>d</sub> = 5622 <sub>h</sub>	
<a href="#">▶ Drive interface</a>			
Selection list (Lenze setting printed in bold)		Info	
0	User-defined	The text entered in <a href="#">C02526</a> is displayed for the unit.	
1	Incr.		
2	µm		
3	mm		
4	m		
5	inch		
6	yard		
7	°		
<input checked="" type="checkbox"/> Read access <input checked="" type="checkbox"/> Write access <input type="checkbox"/> CINH <input type="checkbox"/> PLC STOP <input type="checkbox"/> No transfer		Scaling factor: 1	

## C02526

Parameter   Name: <b>C02526   User-defined unit</b>		Data type: VISIBLE_STRING Index: 22049 <sub>d</sub> = 5621 <sub>h</sub>	
User-defined unit which is displayed when <a href="#">C02525</a> ="0" is selected.			
<a href="#">▶ Drive interface</a>			
<input checked="" type="checkbox"/> Read access <input checked="" type="checkbox"/> Write access <input type="checkbox"/> CINH <input type="checkbox"/> PLC STOP <input type="checkbox"/> No transfer		Scaling factor: 1 Character length: 8	

## C02527

Parameter   Name: <b>C02527   Motor mounting direction</b>		Data type: UNSIGNED_32 Index: 22048 <sub>d</sub> = 5620 <sub>h</sub>	
<a href="#">▶ Drive interface</a>			
Selection list (Lenze setting printed in bold)			
0	<b>Motor rotating CW</b>		
1	Motor rotating CCW		
<input checked="" type="checkbox"/> Read access <input checked="" type="checkbox"/> Write access <input checked="" type="checkbox"/> CINH <input type="checkbox"/> PLC STOP <input type="checkbox"/> No transfer		Scaling factor: 1	

## C02528

Parameter   Name: <b>C02528   Traversing range</b>		Data type: UNSIGNED_32 Index: 22047 <sub>d</sub> = 561F <sub>h</sub>
		<a href="#">▶ Drive interface</a>
<b>Selection list</b> (Lenze setting printed in bold)		
0	<b>Unlimited</b>	
1	Limited	
2	Modulo	
<input checked="" type="checkbox"/> Read access <input checked="" type="checkbox"/> Write access <input checked="" type="checkbox"/> CINH <input type="checkbox"/> PLC STOP <input type="checkbox"/> No transfer		Scaling factor: 1

## C02529

Parameter   Name: <b>C02529   Position encoder mounting dir.</b>		Data type: UNSIGNED_32 Index: 22046 <sub>d</sub> = 561E <sub>h</sub>
		<a href="#">▶ Drive interface</a>
<b>Selection list</b> (Lenze setting printed in bold)		
0	<b>Encoder rotating CW</b>	
1	Encoder rotating CCW	
<input checked="" type="checkbox"/> Read access <input checked="" type="checkbox"/> Write access <input checked="" type="checkbox"/> CINH <input type="checkbox"/> PLC STOP <input type="checkbox"/> No transfer		Scaling factor: 1

## C02530

Parameter   Name: <b>C02530   Active function state</b>		Data type: INTEGER_32 Index: 22045 <sub>d</sub> = 561D <sub>h</sub>
Displays the basic drive function that currently controls the drive.		<a href="#">▶ Basic drive functions: Internal state machine</a>
<b>Selection list</b> (read only)		
0	Program stopped	
1	Initial/boot state active	
2	Torque follower active	
3	Speed follower active	
4	Position follower active	
5	Setpoint follower active	
6	Positioning active	
7	Homing active	
8	Manual jog active	
9	Brake test active	
10	Drive at standstill	
11	Drive is stopped	
12	Quick stop active	
13	Reserve 1	
14	Controller is not ready	
15	Initialisation	
16	Error	
17	Encoderless manual jog active	
18	Pole position identification active	
<input checked="" type="checkbox"/> Read access <input type="checkbox"/> Write access <input type="checkbox"/> CINH <input type="checkbox"/> PLC STOP <input type="checkbox"/> No transfer		Scaling factor: 1

## C02531

Parameter   Name: <b>C02531   Gearbox factors (decimal)</b>		Data type: UNSIGNED_32 Index: 22044 <sub>d</sub> = 561C <sub>h</sub>
<p><b>Note:</b> In subcode 3 the effective gearbox factor resulting from the motor and the load is displayed if a separate position encoder is configured and the position control is activated (<a href="#">C02570</a>="2"). For a different encoder configuration (without a separate position encoder) the value "1" is shown in subcode 3.</p> <p style="text-align: right;"><a href="#">▶ Drive interface</a></p>		
<b>Display range (min. value   unit   max. value)</b>		
0.000		2147483.647
<b>Subcodes</b>		<b>Info</b>
C02531/1		Motor gearbox factor (dec.)
C02531/2		Pos. enc. gearbox factor (dec.)
C02531/3		Effective gearbox factor (dec.)
<input checked="" type="checkbox"/> Read access <input type="checkbox"/> Write access <input type="checkbox"/> CINH <input type="checkbox"/> PLC STOP <input type="checkbox"/> No transfer		Scaling factor: 1000

## C02532

Parameter   Name: <b>C02532   Resolution of a unit</b>		Data type: UNSIGNED_32 Index: 22043 <sub>d</sub> = 561B <sub>h</sub>
<a href="#">▶ Drive interface</a>		
<b>Display range (min. value   unit   max. value)</b>		
0.0000	Incr./unit	214748.3647
<input checked="" type="checkbox"/> Read access <input type="checkbox"/> Write access <input type="checkbox"/> CINH <input type="checkbox"/> PLC STOP <input type="checkbox"/> No transfer		Scaling factor: 10000

## C02533

Parameter   Name: <b>C02533   Time unit</b>		Data type: UNSIGNED_32 Index: 22042 <sub>d</sub> = 561A <sub>h</sub>
<a href="#">▶ Drive interface</a>		
<b>Selection list (read only)</b>		
2   s		
<input checked="" type="checkbox"/> Read access <input type="checkbox"/> Write access <input type="checkbox"/> CINH <input type="checkbox"/> PLC STOP <input type="checkbox"/> No transfer		Scaling factor: 1

## C02534

Parameter   Name: <b>C02534   Used time unit</b>		Data type: VISIBLE_STRING Index: 22041 <sub>d</sub> = 5619 <sub>h</sub>
Display of the time unit as a character string		
<a href="#">▶ Drive interface</a>		
<input checked="" type="checkbox"/> Read access <input type="checkbox"/> Write access <input type="checkbox"/> CINH <input type="checkbox"/> PLC STOP <input type="checkbox"/> No transfer		Scaling factor: 1   Character length: 8

## C02535

Parameter   Name: <b>C02535   Used unit</b>		Data type: VISIBLE_STRING Index: 22040 <sub>d</sub> = 5618 <sub>h</sub>
Display of the unit set in <a href="#">C02525</a> and <a href="#">C02526</a> as a character string		
<a href="#">▶ Drive interface</a>		
<input checked="" type="checkbox"/> Read access <input type="checkbox"/> Write access <input type="checkbox"/> CINH <input type="checkbox"/> PLC STOP <input type="checkbox"/> No transfer		Scaling factor: 1   Character length: 8

## C02536

Parameter   Name: <b>C02536   Cycle</b>			Data type: UNSIGNED_32 Index: 22039 <sub>d</sub> = 5617 <sub>h</sub>
			<a href="#">▶ Drive interface</a>
<b>Setting range (min. value   unit   max. value)</b>		<b>Lenze setting</b>	
0.0000	Unit	214748.3647	<b>360.0000 Unit</b>
<input checked="" type="checkbox"/> Read access <input checked="" type="checkbox"/> Write access <input checked="" type="checkbox"/> CINH <input type="checkbox"/> PLC STOP <input type="checkbox"/> No transfer			Scaling factor: 10000

## C02537

Parameter   Name: <b>C02537   Speed unit</b>			Data type: VISIBLE_STRING Index: 22038 <sub>d</sub> = 5616 <sub>h</sub>
			<a href="#">▶ Drive interface</a>
<input checked="" type="checkbox"/> Read access <input type="checkbox"/> Write access <input type="checkbox"/> CINH <input type="checkbox"/> PLC STOP <input type="checkbox"/> No transfer			Scaling factor: 1 Character length: 16

## C02538

Parameter   Name: <b>C02538   Acceleration unit</b>			Data type: VISIBLE_STRING Index: 22037 <sub>d</sub> = 5615 <sub>h</sub>
			<a href="#">▶ Drive interface</a>
<input checked="" type="checkbox"/> Read access <input type="checkbox"/> Write access <input type="checkbox"/> CINH <input type="checkbox"/> PLC STOP <input type="checkbox"/> No transfer			Scaling factor: 1 Character length: 16

## C02539

Parameter   Name: <b>C02539   Max. presentable position</b>			Data type: INTEGER_32 Index: 22036 <sub>d</sub> = 5614 <sub>h</sub>
			<a href="#">▶ Drive interface</a>
<b>Display range (min. value   unit   max. value)</b>			
-214748.3647	Unit	214748.3647	
<input checked="" type="checkbox"/> Read access <input type="checkbox"/> Write access <input type="checkbox"/> CINH <input type="checkbox"/> PLC STOP <input type="checkbox"/> No transfer			Scaling factor: 10000

## C02540

Parameter   Name: <b>C02540   Max. presentable speed</b>			Data type: INTEGER_32 Index: 22035 <sub>d</sub> = 5613 <sub>h</sub>
			<a href="#">▶ Drive interface</a>
<b>Display range (min. value   unit   max. value)</b>			
-214748.3647	Unit/s	214748.3647	
<input checked="" type="checkbox"/> Read access <input type="checkbox"/> Write access <input type="checkbox"/> CINH <input type="checkbox"/> PLC STOP <input type="checkbox"/> No transfer			Scaling factor: 10000

## C02541

Parameter   Name: <b>C02541   Max. presentable acceleration</b>			Data type: INTEGER_32 Index: 22034 <sub>d</sub> = 5612 <sub>h</sub>
			<a href="#">▶ Drive interface</a>
<b>Display range (min. value   unit   max. value)</b>			
-214748.3647	Unit/s <sup>2</sup>	214748.3647	
<input checked="" type="checkbox"/> Read access <input type="checkbox"/> Write access <input type="checkbox"/> CINH <input type="checkbox"/> PLC STOP <input type="checkbox"/> No transfer			Scaling factor: 10000



# 14 Parameter reference

## 14.2 Parameter list | C02542

### C02542

Parameter   Name: <b>C02542   Load reference speed</b>			Data type: UNSIGNED_32 Index: 22033 <sub>d</sub> = 5611 <sub>h</sub>
			<a href="#">▶ Drive interface</a>
<b>Display range (min. value   unit   max. value)</b>			
0.000	rpm	4294967.295	
<input checked="" type="checkbox"/> Read access <input type="checkbox"/> Write access <input type="checkbox"/> CINH <input type="checkbox"/> PLC STOP <input type="checkbox"/> No transfer			Scaling factor: 1000

### C02543

Parameter   Name: <b>C02543   Load reference torque</b>			Data type: UNSIGNED_32 Index: 22032 <sub>d</sub> = 5610 <sub>h</sub>
			<a href="#">▶ Drive interface</a>
<b>Display range (min. value   unit   max. value)</b>			
0.000	Nm	4294967.295	
<input checked="" type="checkbox"/> Read access <input type="checkbox"/> Write access <input type="checkbox"/> CINH <input type="checkbox"/> PLC STOP <input type="checkbox"/> No transfer			Scaling factor: 1000

### C02544

Parameter   Name: <b>C02544   Reference speed</b>			Data type: INTEGER_32 Index: 22031 <sub>d</sub> = 560F <sub>h</sub>
From software version V1.5			<a href="#">▶ Drive interface</a>
<b>Display range (min. value   unit   max. value)</b>			
-214748.3647	Unit/s	214748.3647	
<input checked="" type="checkbox"/> Read access <input type="checkbox"/> Write access <input type="checkbox"/> CINH <input type="checkbox"/> PLC STOP <input type="checkbox"/> No transfer			Scaling factor: 10000

### C02545

Parameter   Name: <b>C02545   Reference S-ramp time</b>			Data type: UNSIGNED_32 Index: 22030 <sub>d</sub> = 560E <sub>h</sub>
From software version V7.0			<a href="#">▶ Drive interface</a>
<b>Setting range (min. value   unit   max. value)</b>		<b>Lenze setting</b>	
0.000	s	2147483.647	<b>0.001 s</b>
<input checked="" type="checkbox"/> Read access <input checked="" type="checkbox"/> Write access <input type="checkbox"/> CINH <input type="checkbox"/> PLC STOP <input type="checkbox"/> No transfer			Scaling factor: 1000

### C02547

Parameter   Name: <b>C02547   DI_dnState</b>			Data type: INTEGER_32 Index: 22028 <sub>d</sub> = 560C <sub>h</sub>
Bit coded status of the <a href="#">drive interface</a> .			
<b>Display range (min. value   unit   max. value)</b>			
-2147483648		2147483647	
<input checked="" type="checkbox"/> Read access <input type="checkbox"/> Write access <input type="checkbox"/> CINH <input type="checkbox"/> PLC STOP <input type="checkbox"/> No transfer			Scaling factor: 1

## C02548

Parameter   Name: C02548   DI_bErrors		Data type: UNSIGNED_32 Index: 22027 <sub>d</sub> = 560B <sub>h</sub>
Display of the digital error signals of the <a href="#">drive interface</a> .		
Selection list (read only)		
0	FALSE	
1	TRUE	
Subcodes	Info	
C02548/1	DI_bResetError1	
C02548/2	DI_bResetError2	
C02548/3	DI_bResetError3	
C02548/4	DI_bSetExternError	
<input checked="" type="checkbox"/> Read access <input type="checkbox"/> Write access <input type="checkbox"/> CINH <input type="checkbox"/> PLC STOP <input type="checkbox"/> No transfer		Scaling factor: 1

## C02549

Parameter   Name: C02549   Drive interface: Signals		Data type: UNSIGNED_32 Index: 22026 <sub>d</sub> = 560A <sub>h</sub>
Display of the digital signals of the <a href="#">drive interface</a> .		
Selection list (read only)		
0	FALSE	
1	TRUE	
Subcodes	Info	
C02549/1	DI_bSetClnh	
C02549/2	Reserved	
C02549/3	Reserved	
C02549/4	DI_bSwitchOn	
C02549/5	Reserved	
C02549/6	DI_bReady	
C02549/7	DI_bFailActive	
C02549/8	DI_bImpActive	
C02549/9	DI_bCinhActive	
C02549/10	DI_bWarningActive	
C02549/11	DI_bUVDetected	
C02549/12	DI_bOVDetected	
C02549/13	DI_bMainSupplyOk	
C02549/14	DI_bReadyToSwitchOn	
C02549/15	DI_bOperationEnabled	
<input checked="" type="checkbox"/> Read access <input type="checkbox"/> Write access <input type="checkbox"/> CINH <input type="checkbox"/> PLC STOP <input type="checkbox"/> No transfer		Scaling factor: 1

## C02550

Parameter   Name: <b>C02550   Setpoint interpolation</b>		Data type: UNSIGNED_32 Index: 22025 <sub>d</sub> = 5609 <sub>h</sub>
<a href="#">▶ Motor interface</a>		
<b>Selection list</b>		
0	Off	
1	On	
<b>Subcodes</b>	<b>Lenze setting</b>	<b>Info</b>
C02550/1	1: On	Position setpoint interpolat.
C02550/2	1: On	Speed setpoint interpolat.
C02550/3	1: On	Torque setpoint interpolat.
<input checked="" type="checkbox"/> Read access <input checked="" type="checkbox"/> Write access <input type="checkbox"/> CINH <input type="checkbox"/> PLC STOP <input type="checkbox"/> No transfer		Scaling factor: 1

## C02552

Parameter   Name: <b>C02552   Position setpoint (mctrl)</b>		Data type: INTEGER_32 Index: 22023 <sub>d</sub> = 5607 <sub>h</sub>
<a href="#">▶ Motor interface</a>		
<b>Display range (min. value   unit   max. value)</b>		
-214748.3647	Unit	214748.3647
<input checked="" type="checkbox"/> Read access <input type="checkbox"/> Write access <input type="checkbox"/> CINH <input type="checkbox"/> PLC STOP <input type="checkbox"/> No transfer		Scaling factor: 10000

## C02553

Parameter   Name: <b>C02553   Position controller gain</b>		Data type: UNSIGNED_32 Index: 22022 <sub>d</sub> = 5606 <sub>h</sub>
<a href="#">▶ Motor interface</a>		
<b>Setting range (min. value   unit   max. value)</b>		<b>Lenze setting</b>
0.00	1/s	1000.00
		<b>20.00 1/s</b>
<input checked="" type="checkbox"/> Read access <input checked="" type="checkbox"/> Write access <input type="checkbox"/> CINH <input type="checkbox"/> PLC STOP <input type="checkbox"/> No transfer		Scaling factor: 100

## C02554

Parameter   Name: <b>C02554   Position controller reset time</b>		Data type: UNSIGNED_32 Index: 22021 <sub>d</sub> = 5605 <sub>h</sub>
<a href="#">▶ Motor interface</a>		
<b>Setting range (min. value   unit   max. value)</b>		<b>Lenze setting</b>
0.001	s	60.000
		<b>60.000 s</b>
<input checked="" type="checkbox"/> Read access <input checked="" type="checkbox"/> Write access <input type="checkbox"/> CINH <input type="checkbox"/> PLC STOP <input type="checkbox"/> No transfer		Scaling factor: 1000

## C02555

Parameter   Name: <b>C02555   D component position controller</b>		Data type: UNSIGNED_32 Index: 22020 <sub>d</sub> = 5604 <sub>h</sub>
<a href="#">▶ Motor interface</a>		
<b>Setting range (min. value   unit   max. value)</b>		<b>Lenze setting</b>
0.000		100.000
		<b>0.000</b>
<input checked="" type="checkbox"/> Read access <input checked="" type="checkbox"/> Write access <input type="checkbox"/> CINH <input type="checkbox"/> PLC STOP <input type="checkbox"/> No transfer		Scaling factor: 1000

## C02556

Parameter   Name: <b>C02556   Pos. contr. limitation</b>			Data type: INTEGER_32 Index: 22019 <sub>d</sub> = 5603 <sub>h</sub>
<a href="#">▶ Motor interface</a>			
<b>Setting range (min. value   unit   max. value)</b>			<b>Lenze setting</b>
0.0000	Unit/s	214748.3647	<b>214748.3647 Unit/s</b>
<input checked="" type="checkbox"/> Read access <input checked="" type="checkbox"/> Write access <input type="checkbox"/> CINH <input type="checkbox"/> PLC STOP <input type="checkbox"/> No transfer			Scaling factor: 10000

## C02557

Parameter   Name: <b>C02557   Phase controller output</b>			Data type: INTEGER_32 Index: 22018 <sub>d</sub> = 5602 <sub>h</sub>
<a href="#">▶ Motor interface</a>			
<b>Display range (min. value   unit   max. value)</b>			
-214748.3647	Unit/s	214748.3647	
<input checked="" type="checkbox"/> Read access <input type="checkbox"/> Write access <input type="checkbox"/> CINH <input type="checkbox"/> PLC STOP <input type="checkbox"/> No transfer			Scaling factor: 10000

## C02558

Parameter   Name: <b>C02558   Pos. contr. output</b>			Data type: INTEGER_32 Index: 22017 <sub>d</sub> = 5601 <sub>h</sub>
<a href="#">▶ Motor interface</a>			
<b>Display range (min. value   unit   max. value)</b>			
-214748.3647	Unit/s	214748.3647	
<input checked="" type="checkbox"/> Read access <input type="checkbox"/> Write access <input type="checkbox"/> CINH <input type="checkbox"/> PLC STOP <input type="checkbox"/> No transfer			Scaling factor: 10000

## C02559

Parameter   Name: <b>C02559   Internal torque limits</b>			Data type: INTEGER_32 Index: 22016 <sub>d</sub> = 5600 <sub>h</sub>
<a href="#">▶ Motor interface</a>			
<b>Display range (min. value   unit   max. value)</b>			
-200.00	%	200.00	
<b>Subcodes</b>		<b>Info</b>	
C02559/1		Upper int. torque limit	
C02559/2		Lower int. torque limit	
<input checked="" type="checkbox"/> Read access <input type="checkbox"/> Write access <input type="checkbox"/> CINH <input type="checkbox"/> PLC STOP <input type="checkbox"/> No transfer			Scaling factor: 100

## C02560

Parameter   Name: <b>C02560   Messages - motor interface</b>			Data type: UNSIGNED_32 Index: 22015 <sub>d</sub> = 55FF <sub>h</sub>
<a href="#">▶ Motor interface</a>			
<b>Display range (min. value   unit   max. value)</b>			
0		4294967295	
<input checked="" type="checkbox"/> Read access <input type="checkbox"/> Write access <input type="checkbox"/> CINH <input type="checkbox"/> PLC STOP <input type="checkbox"/> No transfer			Scaling factor: 1

## C02561

Parameter   Name: <b>C02561   Speed feedforw. control gain</b>		Data type: INTEGER_32 Index: 22014 <sub>d</sub> = 55FE <sub>h</sub>
From software version V1.5 Percentage reduction of the speed feedforward control of the profile generator <ul style="list-style-type: none"> <li>• Required in some applications if a 100 % speed feedforward control causes overshoots.</li> <li>• Only effective for the basic functions "Positioning", "Homing" and "Manual jog".</li> </ul> <p style="text-align: right;"><a href="#">▶ Motor interface</a></p>		
Setting range (min. value   unit   max. value)		Lenze setting
0.00	%	200.00
<input checked="" type="checkbox"/> Read access <input checked="" type="checkbox"/> Write access <input type="checkbox"/> CINH <input type="checkbox"/> PLC STOP <input type="checkbox"/> No transfer		Scaling factor: 100

## C02562

Parameter   Name: <b>C02562   Filter time constant</b>		Data type: UNSIGNED_32 Index: 22013 <sub>d</sub> = 55FD <sub>h</sub>
From software version V7.0 <p style="text-align: right;"><a href="#">▶ Motor interface</a></p>		
Setting range (min. value   unit   max. value)		Lenze setting
0.000	s	60.000
<input checked="" type="checkbox"/> Read access <input checked="" type="checkbox"/> Write access <input type="checkbox"/> CINH <input type="checkbox"/> PLC STOP <input type="checkbox"/> No transfer		Scaling factor: 1000

## C02564

Parameter   Name: <b>C02564   Service code</b>		Data type: BITFIELD_8 Index: 22011 <sub>d</sub> = 55FB <sub>h</sub>
From software version V9.0 <p style="text-align: right;"><a href="#">▶ Motor interface</a></p>		
Setting range		Lenze setting
0x00		0xFF
<b>Value is bit-coded: (<input checked="" type="checkbox"/> = bit set)</b>		<b>Info</b>
Bit 0 <input type="checkbox"/>	Option 0	
Bit 1 <input type="checkbox"/>	Option 1	
Bit 2 <input type="checkbox"/>	Option 2	
Bit 3 <input type="checkbox"/>	Option 3	
Bit 4 <input type="checkbox"/>	Option 4	
Bit 5 <input type="checkbox"/>	Option 5	
Bit 6 <input type="checkbox"/>	Option 6	
<input checked="" type="checkbox"/> Read access <input checked="" type="checkbox"/> Write access <input type="checkbox"/> CINH <input type="checkbox"/> PLC STOP <input type="checkbox"/> No transfer		Scaling factor: 1

## C02567

Parameter   Name: <b>C02567   Control mode</b>		Data type: UNSIGNED_32 Index: 22008 <sub>d</sub> = 55F8 <sub>h</sub>
<p style="text-align: right;"><a href="#">▶ Motor interface</a></p>		
Selection list (read only)		
0	Position control	
1	closed-loop speed control	
2	Closed-loop torque control	
<input checked="" type="checkbox"/> Read access <input type="checkbox"/> Write access <input type="checkbox"/> CINH <input type="checkbox"/> PLC STOP <input type="checkbox"/> No transfer		Scaling factor: 1

## C02568

Parameter   Name: C02568   Motor interface: % signals		Data type: INTEGER_32 Index: 22007 <sub>d</sub> = 55F7 <sub>h</sub>
Display of the scaled signals of the <a href="#">motor interface</a> .		
Display range (min. value   unit   max. value)		
-200.00	%	200.00
Subcodes	Info	
C02568/1	MI_dnPosCtrlAdaptLoad_n	
C02568/2	MI_dnPosCtrlAdaptMotor_n	
C02568/3	MI_dnSpeedCtrlAdapt_n	
C02568/4	MI_dnTorqueHighLimit_n	
C02568/5	MI_dnTorqueLowLimit_n	
C02568/6	MI_dnTorqueCtrlAdapt_n	
C02568/7	MI_dnFluxSetpoint_n	
C02568/8	MI_dnInertiaAdapt_n	
C02568/9	MI_dnBoostSet_n	
C02568/10	MI_dnTorqueAdd_n	
<input checked="" type="checkbox"/> Read access <input type="checkbox"/> Write access <input type="checkbox"/> CINH <input type="checkbox"/> PLC STOP <input type="checkbox"/> No transfer		Scaling factor: 100

## C02569

Parameter   Name: C02569   Motor interface.: Dig. signals		Data type: UNSIGNED_32 Index: 22006 <sub>d</sub> = 55F6 <sub>h</sub>
Display of the digital signals of the <a href="#">motor interface</a> .		
Selection list (read only)		
0	FALSE	
1	TRUE	
Subcodes	Info	
C02569/1	Reserved	
C02569/2	MI_bResetSpeedCtrlIntegrator	
C02569/3	MI_bLimitationActive	
C02569/4	MI_bPosCtrlLimited	
C02569/5	MI_bSpeedSetPointLimited	
C02569/6	MI_bSpeedCtrlLimited	
C02569/7	MI_bTorqueSetpointLimited	
C02569/8	MI_bCurrentSetpointLimited	
C02569/9	MI_bSpeedBelowC19	
C02569/10	MI_bSpeedFollowingError	
C02569/11	MI_bMotorOverloadWarning	
C02569/12	MI_bMotorOrientationInverse	
C02569/13	MI_bFlyingSyncBusy	
C02569/14	MI_bClampsActive	
C02569/15	MI_bMagnetisationFinished	
C02569/16	MI_bFlyingSyncBlocked	
<input checked="" type="checkbox"/> Read access <input type="checkbox"/> Write access <input type="checkbox"/> CINH <input type="checkbox"/> PLC STOP <input type="checkbox"/> No transfer		Scaling factor: 1

## C02570

Parameter   Name: <b>C02570   Position control structure</b>		Data type: UNSIGNED_32 Index: 22005 <sub>d</sub> = 55F5 <sub>h</sub>
Chapter " <a href="#">Controller configuration</a> " provides you with more information on parameter setting. <a href="#">▶ Encoder evaluation</a>		
Selection list (Lenze setting printed in bold)		Info
1	<b>Phase controller is active</b>	Motor encoder selection is effected in <a href="#">C00495</a> .
2	Position controller active (<= FW V5.xx)	Position controller selection is effected in <a href="#">C00490</a> .
3	Position controller is active	Position controller selection is effected in <a href="#">C00490</a> .
<input checked="" type="checkbox"/> Read access <input checked="" type="checkbox"/> Write access <input checked="" type="checkbox"/> CINH <input type="checkbox"/> PLC STOP <input type="checkbox"/> No transfer		Scaling factor: 1

## C02571

Parameter   Name: <b>C02571   Source - actual position</b>		Data type: UNSIGNED_32 Index: 22004 <sub>d</sub> = 55F4 <sub>h</sub>
<b>This code is for device-internal use only and must not be written to by the user!</b>		

## C02572

Parameter   Name: <b>C02572   Speed setpoint (enc. eval.)</b>		Data type: INTEGER_32 Index: 22003 <sub>d</sub> = 55F3 <sub>h</sub>
<a href="#">▶ Encoder evaluation</a>		
Display range (min. value   unit   max. value)		
-214748.3647	Unit/s	214748.3647
<input checked="" type="checkbox"/> Read access <input type="checkbox"/> Write access <input type="checkbox"/> CINH <input type="checkbox"/> PLC STOP <input type="checkbox"/> No transfer		Scaling factor: 10000

## C02573

Parameter   Name: <b>C02573   Position setpoint (enc. eval.)</b>		Data type: INTEGER_32 Index: 22002 <sub>d</sub> = 55F2 <sub>h</sub>
<a href="#">▶ Encoder evaluation</a>		
Display range (min. value   unit   max. value)		
-214748.3647	Unit	214748.3647
<input checked="" type="checkbox"/> Read access <input type="checkbox"/> Write access <input type="checkbox"/> CINH <input type="checkbox"/> PLC STOP <input type="checkbox"/> No transfer		Scaling factor: 10000

## C02574

Parameter   Name: <b>C02574   Actual speed (enc. eval.)</b>		Data type: INTEGER_32 Index: 22001 <sub>d</sub> = 55F1 <sub>h</sub>
<a href="#">▶ Encoder evaluation</a>		
Display range (min. value   unit   max. value)		
-214748.3647	Unit/s	214748.3647
<input checked="" type="checkbox"/> Read access <input type="checkbox"/> Write access <input type="checkbox"/> CINH <input type="checkbox"/> PLC STOP <input type="checkbox"/> No transfer		Scaling factor: 10000

## C02575

Parameter   Name: <b>C02575   Actual position (enc. eval.)</b>			Data type: INTEGER_32 Index: 22000 <sub>d</sub> = 55F0 <sub>h</sub>
<a href="#">▶ Encoder evaluation</a>			
<b>Display range (min. value   unit   max. value)</b>			
-214748.3647	Unit	214748.3647	
<input checked="" type="checkbox"/> Read access <input type="checkbox"/> Write access <input type="checkbox"/> CINH <input type="checkbox"/> PLC STOP <input type="checkbox"/> No transfer			Scaling factor: 10000

## C02576

Parameter   Name: <b>C02576   Following error</b>			Data type: INTEGER_32 Index: 21999 <sub>d</sub> = 55EF <sub>h</sub>
<a href="#">▶ Encoder evaluation</a>			
<b>Display range (min. value   unit   max. value)</b>			
-214748.3647	Unit	214748.3647	
<input checked="" type="checkbox"/> Read access <input type="checkbox"/> Write access <input type="checkbox"/> CINH <input type="checkbox"/> PLC STOP <input type="checkbox"/> No transfer			Scaling factor: 10000

## C02577

Parameter   Name: <b>C02577   External actual position</b>			Data type: INTEGER_32 Index: 21998 <sub>d</sub> = 55EE <sub>h</sub>
<a href="#">▶ Encoder evaluation</a>			
<b>Display range (min. value   unit   max. value)</b>			
-214748.3647	Unit	214748.3647	
<input checked="" type="checkbox"/> Read access <input type="checkbox"/> Write access <input type="checkbox"/> CINH <input type="checkbox"/> PLC STOP <input type="checkbox"/> No transfer			Scaling factor: 10000

## C02578

Parameter   Name: <b>C02578   Offset actual pos. value/setp.</b>			Data type: INTEGER_32 Index: 21997 <sub>d</sub> = 55ED <sub>h</sub>
<a href="#">▶ Encoder evaluation</a>			
<b>Display range (min. value   unit   max. value)</b>			
-214748.3647	Unit	214748.3647	
<input checked="" type="checkbox"/> Read access <input type="checkbox"/> Write access <input type="checkbox"/> CINH <input type="checkbox"/> PLC STOP <input type="checkbox"/> No transfer			Scaling factor: 10000

## C02579

Parameter   Name: <b>C02579   Encoder eval.: Dig. signals</b>			Data type: UNSIGNED_32 Index: 21996 <sub>d</sub> = 55EC <sub>h</sub>
Display of the digital signals of the <a href="#">encoder evaluation</a> .			
<b>Selection list (read only)</b>			
0	FALSE		
1	TRUE		
<b>Subcodes</b>		<b>Info</b>	
C02579/1		FDB_bResolverError	
C02579/2		FDB_bSinCosSignalError	
C02579/3		FDB_bEncoderComError	
C02579/4		FDB_bResetPosFollowingError	
<input checked="" type="checkbox"/> Read access <input type="checkbox"/> Write access <input type="checkbox"/> CINH <input type="checkbox"/> PLC STOP <input type="checkbox"/> No transfer			Scaling factor: 1



## C02580

Parameter   Name: C02580   Operating mode brake		Data type: UNSIGNED_32 Index: 21995 <sub>d</sub> = 55EB <sub>h</sub>
▶ Basic function " <a href="#">Brake control</a> "		
Selection list (Lenze setting printed in bold)		
0	<b>Brake control off</b>	
1	Directly with brake module	
2	Autom. with brake module	
11	Directly - external switching	
12	Autom. - external switching	
22	Autom. - DC brake	
<input checked="" type="checkbox"/> Read access <input checked="" type="checkbox"/> Write access <input checked="" type="checkbox"/> CINH <input type="checkbox"/> PLC STOP <input type="checkbox"/> No transfer		Scaling factor: 1

## C02581

Parameter   Name: C02581   Threshold - brake activation		Data type: INTEGER_32 Index: 21994 <sub>d</sub> = 55EA <sub>h</sub>
▶ Basic function " <a href="#">Brake control</a> "		
Setting range (min. value   unit   max. value)		Lenze setting
0	rpm	50000
		<b>50 rpm</b>
<input checked="" type="checkbox"/> Read access <input checked="" type="checkbox"/> Write access <input type="checkbox"/> CINH <input type="checkbox"/> PLC STOP <input type="checkbox"/> No transfer		Scaling factor: 1

## C02582

Parameter   Name: C02582   Brake resp. to pulse inhibit		Data type: UNSIGNED_32 Index: 21993 <sub>d</sub> = 55E9 <sub>h</sub>
▶ Basic function " <a href="#">Brake control</a> "		
Selection list (Lenze setting printed in bold)		
0	<b>Activate the brake immediately</b>	
1	Activate brake when n < nmin	
<input checked="" type="checkbox"/> Read access <input checked="" type="checkbox"/> Write access <input type="checkbox"/> CINH <input type="checkbox"/> PLC STOP <input type="checkbox"/> No transfer		Scaling factor: 1

## C02583

Parameter   Name: C02583   Status input monitoring		Data type: UNSIGNED_32 Index: 21992 <sub>d</sub> = 55E8 <sub>h</sub>
▶ Basic function " <a href="#">Brake control</a> "		
Selection list (Lenze setting printed in bold)		
0	<b>Not active</b>	
1	Active	
<input checked="" type="checkbox"/> Read access <input checked="" type="checkbox"/> Write access <input type="checkbox"/> CINH <input type="checkbox"/> PLC STOP <input type="checkbox"/> No transfer		Scaling factor: 1

## C02585

Parameter   Name: <b>C02585   Brake control polarity</b>		Data type: UNSIGNED_32 Index: 21990 <sub>d</sub> = 55E6 <sub>h</sub>	
▶ Basic function " <a href="#">Brake control</a> "			
<b>Selection list</b> (Lenze setting printed in bold)			
0	<b>Not inverted</b>		
1	Inverted		
<input checked="" type="checkbox"/> Read access		<input checked="" type="checkbox"/> Write access	
<input type="checkbox"/> CINH		<input type="checkbox"/> PLC STOP	
<input type="checkbox"/> No transfer		Scaling factor: 1	

## C02586

Parameter   Name: <b>C02586   Starting torque 1</b>		Data type: INTEGER_32 Index: 21989 <sub>d</sub> = 55E5 <sub>h</sub>	
▶ Basic function " <a href="#">Brake control</a> "			
<b>Setting range</b> (min. value   unit   max. value)		<b>Lenze setting</b>	
-21474836.47	Nm	21474836.47	<b>0.00 Nm</b>
<input checked="" type="checkbox"/> Read access		<input checked="" type="checkbox"/> Write access	
<input type="checkbox"/> CINH		<input type="checkbox"/> PLC STOP	
<input type="checkbox"/> No transfer		Scaling factor: 100	

## C02587

Parameter   Name: <b>C02587   Starting torque 2</b>		Data type: INTEGER_32 Index: 21988 <sub>d</sub> = 55E4 <sub>h</sub>	
▶ Basic function " <a href="#">Brake control</a> "			
<b>Setting range</b> (min. value   unit   max. value)		<b>Lenze setting</b>	
-21474836.47	Nm	21474836.47	<b>0.00 Nm</b>
<input checked="" type="checkbox"/> Read access		<input checked="" type="checkbox"/> Write access	
<input type="checkbox"/> CINH		<input type="checkbox"/> PLC STOP	
<input type="checkbox"/> No transfer		Scaling factor: 100	

## C02588

Parameter   Name: <b>C02588   Source of starting torque</b>		Data type: UNSIGNED_32 Index: 21987 <sub>d</sub> = 55E3 <sub>h</sub>	
▶ Basic function " <a href="#">Brake control</a> "			
<b>Selection list</b> (Lenze setting printed in bold)			
0	<b>Starting torque 1/2</b>		
1	Stopping value		
<input checked="" type="checkbox"/> Read access		<input checked="" type="checkbox"/> Write access	
<input type="checkbox"/> CINH		<input type="checkbox"/> PLC STOP	
<input type="checkbox"/> No transfer		Scaling factor: 1	

## C02589

Parameter   Name: <b>C02589   Brake closing time</b>		Data type: UNSIGNED_32 Index: 21986 <sub>d</sub> = 55E2 <sub>h</sub>	
▶ Basic function " <a href="#">Brake control</a> "			
<b>Setting range</b> (min. value   unit   max. value)		<b>Lenze setting</b>	
0	ms	60000	<b>100 ms</b>
<input checked="" type="checkbox"/> Read access		<input checked="" type="checkbox"/> Write access	
<input type="checkbox"/> CINH		<input type="checkbox"/> PLC STOP	
<input type="checkbox"/> No transfer		Scaling factor: 1	

## C02590

Parameter   Name: <b>C02590   Brake opening time</b>			Data type: UNSIGNED_32 Index: 21985 <sub>d</sub> = 55E1 <sub>h</sub>
▶ Basic function " <a href="#">Brake control</a> "			
<b>Setting range (min. value   unit   max. value)</b>			<b>Lenze setting</b>
0	ms	60000	<b>100 ms</b>
<input checked="" type="checkbox"/> Read access <input checked="" type="checkbox"/> Write access <input type="checkbox"/> CINH <input type="checkbox"/> PLC STOP <input type="checkbox"/> No transfer			Scaling factor: 1

## C02591

Parameter   Name: <b>C02591   Waiting time - state monitoring</b>			Data type: UNSIGNED_32 Index: 21984 <sub>d</sub> = 55E0 <sub>h</sub>
▶ Basic function " <a href="#">Brake control</a> "			
<b>Setting range (min. value   unit   max. value)</b>			<b>Lenze setting</b>
0	ms	60000	<b>100 ms</b>
<input checked="" type="checkbox"/> Read access <input checked="" type="checkbox"/> Write access <input type="checkbox"/> CINH <input type="checkbox"/> PLC STOP <input type="checkbox"/> No transfer			Scaling factor: 1

## C02593

Parameter   Name: <b>C02593   Waiting time - brake activation</b>			Data type: UNSIGNED_32 Index: 21982 <sub>d</sub> = 55DE <sub>h</sub>
▶ Basic function " <a href="#">Brake control</a> "			
<b>Setting range (min. value   unit   max. value)</b>			<b>Lenze setting</b>
0.000	s	1000.000	<b>0.000 s</b>
<input checked="" type="checkbox"/> Read access <input checked="" type="checkbox"/> Write access <input type="checkbox"/> CINH <input type="checkbox"/> PLC STOP <input type="checkbox"/> No transfer			Scaling factor: 1000

## C02594

Parameter   Name: <b>C02594   Test torque</b>			Data type: INTEGER_32 Index: 21981 <sub>d</sub> = 55DD <sub>h</sub>
▶ Basic function " <a href="#">Brake control</a> "			
<b>Setting range (min. value   unit   max. value)</b>			<b>Lenze setting</b>
-21474836.47	Nm	21474836.47	<b>0.00 Nm</b>
<input checked="" type="checkbox"/> Read access <input checked="" type="checkbox"/> Write access <input type="checkbox"/> CINH <input type="checkbox"/> PLC STOP <input type="checkbox"/> No transfer			Scaling factor: 100

## C02595

Parameter   Name: <b>C02595   Permissible angle of rotation</b>			Data type: INTEGER_32 Index: 21980 <sub>d</sub> = 55DC <sub>h</sub>
▶ Basic function " <a href="#">Brake control</a> "			
<b>Setting range (min. value   unit   max. value)</b>			<b>Lenze setting</b>
0	°	36000	<b>5 °</b>
<input checked="" type="checkbox"/> Read access <input checked="" type="checkbox"/> Write access <input type="checkbox"/> CINH <input type="checkbox"/> PLC STOP <input type="checkbox"/> No transfer			Scaling factor: 1

## C02596

Parameter   Name: <b>C02596   Grinding speed</b>			Data type: INTEGER_32 Index: 21979 <sub>d</sub> = 55DB <sub>h</sub>
▶ Basic function " <a href="#">Brake control</a> "			
<b>Setting range (min. value   unit   max. value)</b>			<b>Lenze setting</b>
0	rpm	300	<b>100 rpm</b>
<input checked="" type="checkbox"/> Read access <input checked="" type="checkbox"/> Write access <input type="checkbox"/> CINH <input type="checkbox"/> PLC STOP <input type="checkbox"/> No transfer			Scaling factor: 1

## C02597

Parameter   Name: <b>C02597   Accel./decel. time - grinding</b>			Data type: UNSIGNED_32 Index: 21978 <sub>d</sub> = 55DA <sub>h</sub>
▶ Basic function " <a href="#">Brake control</a> "			
<b>Setting range (min. value   unit   max. value)</b>			<b>Lenze setting</b>
0.000	s	60.000	<b>1.000 s</b>
<input checked="" type="checkbox"/> Read access <input checked="" type="checkbox"/> Write access <input type="checkbox"/> CINH <input type="checkbox"/> PLC STOP <input type="checkbox"/> No transfer			Scaling factor: 1000

## C02598

Parameter   Name: <b>C02598   Grinding ON time</b>			Data type: UNSIGNED_32 Index: 21977 <sub>d</sub> = 55D9 <sub>h</sub>
▶ Basic function " <a href="#">Brake control</a> "			
<b>Setting range (min. value   unit   max. value)</b>			<b>Lenze setting</b>
0.2	s	2.0	<b>0.5 s</b>
<input checked="" type="checkbox"/> Read access <input checked="" type="checkbox"/> Write access <input type="checkbox"/> CINH <input type="checkbox"/> PLC STOP <input type="checkbox"/> No transfer			Scaling factor: 10

## C02599

Parameter   Name: <b>C02599   Grinding OFF time</b>			Data type: UNSIGNED_32 Index: 21976 <sub>d</sub> = 55D8 <sub>h</sub>
▶ Basic function " <a href="#">Brake control</a> "			
<b>Setting range (min. value   unit   max. value)</b>			<b>Lenze setting</b>
0.2	s	2.0	<b>0.5 s</b>
<input checked="" type="checkbox"/> Read access <input checked="" type="checkbox"/> Write access <input type="checkbox"/> CINH <input type="checkbox"/> PLC STOP <input type="checkbox"/> No transfer			Scaling factor: 10

## C02600

Parameter   Name: <b>C02600   Acceleration time feedf. control</b>			Data type: UNSIGNED_32 Index: 21975 <sub>d</sub> = 55D7 <sub>h</sub>
<a href="#">From software version V3.0</a>			
▶ Basic function " <a href="#">Brake control</a> "			
<b>Setting range (min. value   unit   max. value)</b>			<b>Lenze setting</b>
0.000	s	1000.000	<b>0.000 s</b>
<input checked="" type="checkbox"/> Read access <input checked="" type="checkbox"/> Write access <input type="checkbox"/> CINH <input type="checkbox"/> PLC STOP <input type="checkbox"/> No transfer			Scaling factor: 1000

## C02601

Parameter   Name: <b>C02601   Ref. for Accel. time of brake</b>		Data type: UNSIGNED_32 Index: 21974 <sub>d</sub> = 55D6 <sub>h</sub>
From software version V3.0		▶ Basic function " <a href="#">Brake control</a> "
<b>Selection list</b> (Lenze setting printed in bold)		
0	<b>Motor reference value</b>	
1	Current starting value	
<input checked="" type="checkbox"/> Read access <input checked="" type="checkbox"/> Write access <input type="checkbox"/> CINH <input type="checkbox"/> PLC STOP <input type="checkbox"/> No transfer		Scaling factor: 1

## C02602

Parameter   Name: <b>C02602   Source for feedf. control brake</b>		Data type: UNSIGNED_32 Index: 21973 <sub>d</sub> = 55D5 <sub>h</sub>
From software version V3.0		▶ Basic function " <a href="#">Brake control</a> "
<b>Selection list</b> (Lenze setting printed in bold)		
0	<b>Torque</b>	
1	Speed	
<input checked="" type="checkbox"/> Read access <input checked="" type="checkbox"/> Write access <input type="checkbox"/> CINH <input type="checkbox"/> PLC STOP <input type="checkbox"/> No transfer		Scaling factor: 1

## C02603

Parameter   Name: <b>C02603   Threshold 1 for opening brake</b>		Data type: INTEGER_32 Index: 21972 <sub>d</sub> = 55D4 <sub>h</sub>
From software version V3.0		▶ Basic function " <a href="#">Brake control</a> "
<b>Setting range</b> (min. value   unit   max. value)		<b>Lenze setting</b>
-50000	rpm	50000
		<b>0 rpm</b>
<input checked="" type="checkbox"/> Read access <input checked="" type="checkbox"/> Write access <input type="checkbox"/> CINH <input type="checkbox"/> PLC STOP <input type="checkbox"/> No transfer		Scaling factor: 1

## C02604

Parameter   Name: <b>C02604   Threshold 2 for opening brake</b>		Data type: INTEGER_32 Index: 21971 <sub>d</sub> = 55D3 <sub>h</sub>
From software version V3.0		▶ Basic function " <a href="#">Brake control</a> "
<b>Setting range</b> (min. value   unit   max. value)		<b>Lenze setting</b>
-50000	rpm	50000
		<b>0 rpm</b>
<input checked="" type="checkbox"/> Read access <input checked="" type="checkbox"/> Write access <input type="checkbox"/> CINH <input type="checkbox"/> PLC STOP <input type="checkbox"/> No transfer		Scaling factor: 1

## C02605

Parameter   Name: <b>C02605   Brake test - time</b>		Data type: UNSIGNED_16 Index: 21970 <sub>d</sub> = 55D2 <sub>h</sub>
From software version V10.0		
<b>Setting range (min. value   unit   max. value)</b>		
0.001	s	65.535
<b>Subcodes</b>	<b>Lenze setting</b>	<b>Info</b>
C02605/1	1.024 s	Brake test - ramp-up time
C02605/2	4.000 s	Brake test - constant ph. time
C02605/3	1.024 s	Brake test - ramp-down time
<input checked="" type="checkbox"/> Read access <input checked="" type="checkbox"/> Write access <input type="checkbox"/> CINH <input type="checkbox"/> PLC STOP <input type="checkbox"/> No transfer		Scaling factor: 1000

## C02606

Parameter   Name: <b>C02606   Minimum starting torque</b>		Data type: INTEGER_32 Index: 21969 <sub>d</sub> = 55D1 <sub>h</sub>
From software version V15.0 onwards		
Minimum starting torque that is built when the holding brake is released.		
<a href="#">▶ Brake control</a>		
<b>Setting range (min. value   unit   max. value)</b>		<b>Lenze setting</b>
-21474836.47	Nm	21474836.47 <b>0.00 Nm</b>
<input checked="" type="checkbox"/> Read access <input checked="" type="checkbox"/> Write access <input type="checkbox"/> CINH <input type="checkbox"/> PLC STOP <input type="checkbox"/> No transfer		Scaling factor: 100

## C02607

Parameter   Name: <b>C02607   BRK_dnState</b>		Data type: INTEGER_32 Index: 21968 <sub>d</sub> = 55D0 <sub>h</sub>
Bit coded status of the basic function " <a href="#">Brake control</a> ".		
<b>Display range (min. value   unit   max. value)</b>		
-2147483648		2147483647
<input checked="" type="checkbox"/> Read access <input type="checkbox"/> Write access <input type="checkbox"/> CINH <input type="checkbox"/> PLC STOP <input type="checkbox"/> No transfer		Scaling factor: 1

## C02608

Parameter   Name: <b>C02608   BRK_dnTorqueAdd_n</b>		Data type: INTEGER_32 Index: 21967 <sub>d</sub> = 55CF <sub>h</sub>
Display of the additive torque value of the basic function " <a href="#">brake control</a> ".		
<b>Display range (min. value   unit   max. value)</b>		
-200.00	%	200.00
<input checked="" type="checkbox"/> Read access <input type="checkbox"/> Write access <input type="checkbox"/> CINH <input type="checkbox"/> PLC STOP <input type="checkbox"/> No transfer		Scaling factor: 100

## C02609

Parameter   Name:		Data type: UNSIGNED_32 Index: 21966 <sub>d</sub> = 55CE <sub>h</sub>	
<b>C02609   Brake control: Dig. signals</b>			
Display of the digital signals of the basic function " <a href="#">brake control</a> ".			
Selection list (read only)			
0	FALSE		
1	TRUE		
Subcodes		Info	
C02609/1		BRK_bReleaseBrake	
C02609/2		BRK_bStartingTorque2	
C02609/3		BRK_bBrakeApplied	
C02609/4		BRK_bBrakeTest	
C02609/5		BRK_bBrakeGrindIn	
C02609/6		BRK_bReleaseBrakeOut	
C02609/7		BRK_bBrakeReleased	
C02609/8		BRK_bError	
C02609/9		BRK_bClnhActive	
C02609/10		BRK_bDisableStop	
<input checked="" type="checkbox"/> Read access		<input type="checkbox"/> Write access	
<input type="checkbox"/> CINH		<input type="checkbox"/> PLC STOP	
<input type="checkbox"/> No transfer		Scaling factor: 1	

## C02610

Parameter   Name:		Data type: UNSIGNED_32 Index: 21965 <sub>d</sub> = 55CD <sub>h</sub>	
<b>C02610   Deceleration time for stop</b>			
▶ Basic function " <a href="#">Stop</a> "			
Setting range (min. value   unit   max. value)		Lenze setting	
0.000	s	1000.000	<b>1.000 s</b>
<input checked="" type="checkbox"/> Read access		<input checked="" type="checkbox"/> Write access	
<input type="checkbox"/> CINH		<input type="checkbox"/> PLC STOP	
<input type="checkbox"/> No transfer		Scaling factor: 1000	

## C02611

Parameter   Name:		Data type: UNSIGNED_32 Index: 21964 <sub>d</sub> = 55CC <sub>h</sub>	
<b>C02611   S-ramp time for stop</b>			
▶ Basic function " <a href="#">Stop</a> "			
Setting range (min. value   unit   max. value)		Lenze setting	
0.000	s	10.000	<b>0.100 s</b>
<input checked="" type="checkbox"/> Read access		<input checked="" type="checkbox"/> Write access	
<input type="checkbox"/> CINH		<input type="checkbox"/> PLC STOP	
<input type="checkbox"/> No transfer		Scaling factor: 1000	

## C02612

Parameter   Name:		Data type: UNSIGNED_32 Index: 21963 <sub>d</sub> = 55CB <sub>h</sub>	
<b>C02612   Ref. for decel. time of stop</b>			
▶ Basic function " <a href="#">Stop</a> "			
Selection list (Lenze setting printed in bold)			
0	<b>Motor reference speed (C00011)</b>		
1	Current speed		
<input checked="" type="checkbox"/> Read access		<input checked="" type="checkbox"/> Write access	
<input type="checkbox"/> CINH		<input type="checkbox"/> PLC STOP	
<input type="checkbox"/> No transfer		Scaling factor: 1	

## C02616

Parameter   Name: <b>C02616   STP_dnState</b>		Data type: INTEGER_32 Index: 21959 <sub>d</sub> = 55C7 <sub>h</sub>
Bit coded status of the basic function " <a href="#">Stop</a> ".		
<b>Display range (min. value   unit   max. value)</b>		
-2147483648		2147483647
<input checked="" type="checkbox"/> Read access <input type="checkbox"/> Write access <input type="checkbox"/> CINH <input type="checkbox"/> PLC STOP <input type="checkbox"/> No transfer		Scaling factor: 1

## C02617

Parameter   Name: <b>C02617   STP_bStopActive</b>		Data type: UNSIGNED_32 Index: 21958 <sub>d</sub> = 55C6 <sub>h</sub>
Status of the basic function " <a href="#">Stop</a> ".		
<b>Selection list (read only)</b>		
0	Normal stop not active	
1	Normal stop active	
<input checked="" type="checkbox"/> Read access <input type="checkbox"/> Write access <input type="checkbox"/> CINH <input type="checkbox"/> PLC STOP <input type="checkbox"/> No transfer		Scaling factor: 1

## C02619

Parameter   Name: <b>C02619   Quick stop: Dig. signals</b>		Data type: UNSIGNED_32 Index: 21956 <sub>d</sub> = 55C4 <sub>h</sub>
Display of the digital signals of the basic function " <a href="#">Quick stop</a> ".		
<b>Selection list (read only)</b>		
0	FALSE	
1	TRUE	
<b>Subcodes</b>		<b>Info</b>
C02619/1		QSP_bActivate1
C02619/2		QSP_bActivate2
C02619/3		QSP_bActivate3
C02619/4		QSP_bActive
C02619/5		QSP_bActivateDCBrake
<input checked="" type="checkbox"/> Read access <input type="checkbox"/> Write access <input type="checkbox"/> CINH <input type="checkbox"/> PLC STOP <input type="checkbox"/> No transfer		Scaling factor: 1

## C02620

Parameter   Name: <b>C02620   Manual jog: Speed 1</b>		Data type: INTEGER_32 Index: 21955 <sub>d</sub> = 55C3 <sub>h</sub>
▶ Basic function " <a href="#">Manual jog</a> "		
<b>Setting range (min. value   unit   max. value)</b>		<b>Lenze setting</b>
0.0000	Unit/s	214748.3647 <b>360.0000 Unit/s</b>
<input checked="" type="checkbox"/> Read access <input checked="" type="checkbox"/> Write access <input type="checkbox"/> CINH <input type="checkbox"/> PLC STOP <input type="checkbox"/> No transfer		Scaling factor: 10000



## C02621

Parameter   Name: <b>C02621   Manual jog: Speed 2</b>			Data type: INTEGER_32 Index: 21954 <sub>d</sub> = 55C2 <sub>h</sub>
▶ Basic function " <a href="#">Manual jog</a> "			
<b>Setting range (min. value   unit   max. value)</b>			<b>Lenze setting</b>
0.0000	Unit/s	214748.3647	<b>720.0000 Unit/s</b>
<input checked="" type="checkbox"/> Read access <input checked="" type="checkbox"/> Write access <input type="checkbox"/> CINH <input type="checkbox"/> PLC STOP <input type="checkbox"/> No transfer			Scaling factor: 10000

## C02622

Parameter   Name: <b>C02622   Manual jog: Acceleration</b>			Data type: INTEGER_32 Index: 21953 <sub>d</sub> = 55C1 <sub>h</sub>
▶ Basic function " <a href="#">Manual jog</a> "			
<b>Setting range (min. value   unit   max. value)</b>			<b>Lenze setting</b>
0.0000	Unit/s <sup>2</sup>	214748.3647	<b>360.0000 Unit/s<sup>2</sup></b>
<input checked="" type="checkbox"/> Read access <input checked="" type="checkbox"/> Write access <input type="checkbox"/> CINH <input type="checkbox"/> PLC STOP <input type="checkbox"/> No transfer			Scaling factor: 10000

## C02623

Parameter   Name: <b>C02623   Manual jog: Deceleration</b>			Data type: INTEGER_32 Index: 21952 <sub>d</sub> = 55C0 <sub>h</sub>
▶ Basic function " <a href="#">Manual jog</a> "			
<b>Setting range (min. value   unit   max. value)</b>			<b>Lenze setting</b>
0.0000	Unit/s <sup>2</sup>	214748.3647	<b>1440.0000 Unit/s<sup>2</sup></b>
<input checked="" type="checkbox"/> Read access <input checked="" type="checkbox"/> Write access <input type="checkbox"/> CINH <input type="checkbox"/> PLC STOP <input type="checkbox"/> No transfer			Scaling factor: 10000

## C02624

Parameter   Name: <b>C02624   Manual jog: S-ramp time</b>			Data type: UNSIGNED_32 Index: 21951 <sub>d</sub> = 55BF <sub>h</sub>
▶ Basic function " <a href="#">Manual jog</a> "			
<b>Setting range (min. value   unit   max. value)</b>			<b>Lenze setting</b>
0.000	s	10.000	<b>0.100 s</b>
<input checked="" type="checkbox"/> Read access <input checked="" type="checkbox"/> Write access <input type="checkbox"/> CINH <input type="checkbox"/> PLC STOP <input type="checkbox"/> No transfer			Scaling factor: 1000

## C02625

Parameter   Name: <b>C02625   Manual jog: Step size</b>			Data type: INTEGER_32 Index: 21950 <sub>d</sub> = 55BE <sub>h</sub>
From software version V5.0 Step distance for " <a href="#">Manual jog with step limitation</a> " mode.			
▶ Basic function " <a href="#">Manual jog</a> "			
<b>Setting range (min. value   unit   max. value)</b>			<b>Lenze setting</b>
0.0000	Unit	214748.3647	<b>360.0000 Unit</b>
<input checked="" type="checkbox"/> Read access <input checked="" type="checkbox"/> Write access <input type="checkbox"/> CINH <input type="checkbox"/> PLC STOP <input type="checkbox"/> No transfer			Scaling factor: 10000

## C02626

Parameter   Name: <b>C02626   Manual jog:Index Stop position</b>		Data type: INTEGER_32 Index: 21949 <sub>d</sub> = 55BD <sub>h</sub>
<p>From software version V5.0</p> <p>Selection of the breakpoint positions for "<a href="#">Manual jog with breakpoint</a>" mode.</p> <ul style="list-style-type: none"> <li>In connection with a function block instance of type <b>L_PosPositionerTable</b>: The index [1...75] of the table position in the VTPOS table has to be specified, which contains the intermediate stop position x that is to be used.</li> <li>In connection with a function block instance of type <b>L_PosProfileTable</b>: The index [1...4] of the profile data set in the VTPOS table has to be specified, which contains the intermediate stop position x that is to be used.</li> </ul> <p style="text-align: right;">▶ Basic function "<a href="#">Manual jog</a>"</p>		
<b>Setting range</b> (min. value   unit   max. value)		
0		75
<b>Subcodes</b>	<b>Lenze setting</b>	<b>Info</b>
C02626/1	0	Index of the breakpoint positions 1 ... 16
C02626/...		
C02626/16		
<input checked="" type="checkbox"/> Read access <input checked="" type="checkbox"/> Write access <input type="checkbox"/> CINH <input type="checkbox"/> PLC STOP <input type="checkbox"/> No transfer   Scaling factor: 1		

## C02627

Parameter   Name: <b>C02627   Manual jog:Selected Stop position</b>		Data type: INTEGER_32 Index: 21948 <sub>d</sub> = 55BC <sub>h</sub>
<p>From software version V5.0</p> <p>Display of the breakpoint positions selected via <a href="#">C02626/1...16</a> for "<a href="#">Manual jog with breakpoints</a>".</p> <p style="text-align: right;">▶ Basic function "<a href="#">Manual jog</a>"</p>		
<b>Display range</b> (min. value   unit   max. value)		
-214748.3648	Unit	214748.3647
<b>Subcodes</b>		<b>Info</b>
C02627/1		Breakpoint position 1 ... 16
C02627/...		
C02627/16		
<input checked="" type="checkbox"/> Read access <input type="checkbox"/> Write access <input type="checkbox"/> CINH <input type="checkbox"/> PLC STOP <input type="checkbox"/> No transfer   Scaling factor: 10000		

## C02637

Parameter   Name: <b>C02637   MAN_dnSpeedOverride_n</b>		Data type: INTEGER_32 Index: 21938 <sub>d</sub> = 55B2 <sub>h</sub>
<p>From software version V5.0</p> <p>Display of the speed override for the basic function "<a href="#">Manual jog</a>".</p>		
<b>Display range</b> (min. value   unit   max. value)		
-200.00	%	200.00
<input checked="" type="checkbox"/> Read access <input type="checkbox"/> Write access <input type="checkbox"/> CINH <input type="checkbox"/> PLC STOP <input type="checkbox"/> No transfer   Scaling factor: 100		

## C02638

Parameter   Name: <b>C02638   Manual jog: Status</b>		Data type: INTEGER_32 Index: 21937 <sub>d</sub> = 55B1 <sub>h</sub>
Status of the basic function " <a href="#">Manual jog</a> ".		
<b>Display range (min. value   unit   max. value)</b>		
0		8
<input checked="" type="checkbox"/> Read access <input type="checkbox"/> Write access <input type="checkbox"/> CINH <input type="checkbox"/> PLC STOP <input type="checkbox"/> No transfer		Scaling factor: 1

## C02639

Parameter   Name: <b>C02639   Manual jog: Dig. signals</b>		Data type: UNSIGNED_32 Index: 21936 <sub>d</sub> = 55B0 <sub>h</sub>
Display of the digital signals of the basic function " <a href="#">Manual jog</a> ".		
<b>Selection list (read only)</b>		
0	FALSE	
1	TRUE	
<b>Subcodes</b>	<b>Info</b>	
C02639/1	MAN_bEnable	
C02639/2	MAN_bJogPositive	
C02639/3	MAN_bJogNegative	
C02639/4	MAN_bActivateJogSpeed2	
C02639/5	MAN_bReleaseLimitSwitch	
C02639/6	MAN_bEnabled	
C02639/7	MAN_bActive	
C02639/8	MAN_bStepMode	
C02639/9	MAN_bIntermediateStopMode	
<input checked="" type="checkbox"/> Read access <input type="checkbox"/> Write access <input type="checkbox"/> CINH <input type="checkbox"/> PLC STOP <input type="checkbox"/> No transfer		Scaling factor: 1

# 14 Parameter reference

14.2 Parameter list | C02640

---

**C02640**

# 14 Parameter reference

14.2 Parameter list | C02640

---

Parameter   Name: <b>C02640   Homing mode</b>		Data type: UNSIGNED_32 Index: 21935 <sub>d</sub> = 55AF <sub>h</sub>
Selection of the homing mode.		▶ Basic function " <a href="#">Homing</a> "
Selection list (Lenze setting printed in bold)	Info	
0	<b>cw_Rn_TP</b>	Positive direction - via home mark - to TP ▶ <a href="#">Process description</a>
1	<b>ccw_Rn_TP</b>	Negative direction - via home mark - to TP ▶ <a href="#">Process description</a>
2	<b>cw_Lp_ccw_Rn_TP</b>	Pos. direction - reversing to limit switch - via home mark - to TP ▶ <a href="#">Process description</a>
3	<b>ccw_Ln_cw_Rn_TP</b>	Neg. direction - reversing to limit switch - via home mark - to TP ▶ <a href="#">Process description</a>
4	<b>cw_Rp_ccw_Rn_TP</b>	Pos. direction - reversing to home mark - to TP ▶ <a href="#">Process description</a>
5	<b>ccw_Rp_cw_Rn_TP</b>	Neg. direction - reversing to home mark - to TP ▶ <a href="#">Process description</a>
8	<b>cw_TP</b>	Positive direction to touch probe ▶ <a href="#">Process description</a>
9	<b>ccw_TP</b>	Negative direction to touch probe ▶ <a href="#">Process description</a>
10	<b>cw_Lp_ccw_TP</b>	Pos. direction - reversing to limit switch - to TP ▶ <a href="#">Process description</a>
11	<b>ccw_Ln_cw_TP</b>	Neg. direction - reversing to limit switch - to TP ▶ <a href="#">Process description</a>
12	<b>cw_Lp</b>	Positive direction to limit switch ▶ <a href="#">Process description</a>
13	<b>ccw_Ln</b>	Negative direction to limit switch ▶ <a href="#">Process description</a>
14	<b>cw_Trq_Lim</b>	Positive direction to torque limit ▶ <a href="#">Process description</a>
15	<b>ccw_Trq_Lim</b>	Negative direction to torque limit ▶ <a href="#">Process description</a>
<b>100</b>	<b>Directly set reference</b>	Directly set reference ▶ <a href="#">Process description</a>
1001	DS402 homing method 01	From software version V3.0 also the homing methods in accordance with DS402 are provided. ▶ <a href="#">Overview of DS402 homing modes</a>

Parameter   Name: <b>C02640   Homing mode</b>		Data type: UNSIGNED_32 Index: 21935 <sub>d</sub> = 55AF <sub>h</sub>
1002	DS402 homing method 02	
1003	DS402 homing method 03	
1004	DS402 homing method 04	
1005	DS402 homing method 05	
1006	DS402 homing method 06	
1007	DS402 homing method 07	
1008	DS402 homing method 08	
1009	DS402 homing method 09	
1010	DS402 homing method 10	
1011	DS402 homing method 11	
1012	DS402 homing method 12	
1013	DS402 homing method 13	
1014	DS402 homing method 14	
1015	DS402 homing method 15	
1016	DS402 homing method 16	
1017	DS402 homing method 17	
1018	DS402 homing method 18	
1019	DS402 homing method 19	
1020	DS402 homing method 20	
1021	DS402 homing method 21	
1022	DS402 homing method 22	
1023	DS402 homing method 23	
1024	DS402 homing method 24	
1025	DS402 homing method 25	
1026	DS402 homing method 26	
1027	DS402 homing method 27	
1028	DS402 homing method 28	
1029	DS402 homing method 29	
1030	DS402 homing method 30	
1031	DS402 homing method 31	
1032	DS402 homing method 32	
1033	DS402 homing method 33	
1034	DS402 homing method 34	
1035	DS402 homing method 35	
<input checked="" type="checkbox"/> Read access <input checked="" type="checkbox"/> Write access <input type="checkbox"/> CINH <input type="checkbox"/> PLC STOP <input type="checkbox"/> No transfer             Scaling factor: 1		

## C02641

Parameter   Name: <b>C02641   Action after detect Home position</b>		Data type: UNSIGNED_32 Index: 21934 <sub>d</sub> = 55AE <sub>h</sub>	
From software version V4.0			
▶ Basic function " <a href="#">Homing</a> "			
<b>Selection list</b> (Lenze setting printed in bold)			
0	<b>Move absolute on target position</b>		
1	Move relative by Target position		
2	Stop immediately		
<input checked="" type="checkbox"/> Read access		<input checked="" type="checkbox"/> Write access	
<input type="checkbox"/> CINH		<input type="checkbox"/> PLC STOP	
<input type="checkbox"/> No transfer		Scaling factor: 1	

## C02642

Parameter   Name: <b>C02642   Home position</b>		Data type: INTEGER_32 Index: 21933 <sub>d</sub> = 55AD <sub>h</sub>	
▶ Basic function " <a href="#">Homing</a> "			
<b>Setting range</b> (min. value   unit   max. value)		<b>Lenze setting</b>	
-214748.3647	Unit	214748.3647	<b>0.0000 Unit</b>
<input checked="" type="checkbox"/> Read access		<input checked="" type="checkbox"/> Write access	
<input type="checkbox"/> CINH		<input type="checkbox"/> PLC STOP	
<input type="checkbox"/> No transfer		Scaling factor: 10000	

## C02643

Parameter   Name: <b>C02643   Homing: Target position</b>		Data type: INTEGER_32 Index: 21932 <sub>d</sub> = 55AC <sub>h</sub>	
▶ Basic function " <a href="#">Homing</a> "			
<b>Setting range</b> (min. value   unit   max. value)		<b>Lenze setting</b>	
-214748.3647	Unit	214748.3647	<b>0.0000 Unit</b>
<input checked="" type="checkbox"/> Read access		<input checked="" type="checkbox"/> Write access	
<input type="checkbox"/> CINH		<input type="checkbox"/> PLC STOP	
<input type="checkbox"/> No transfer		Scaling factor: 10000	

## C02644

Parameter   Name: <b>C02644   Homing: Speed 1</b>		Data type: INTEGER_32 Index: 21931 <sub>d</sub> = 55AB <sub>h</sub>	
▶ Basic function " <a href="#">Homing</a> "			
<b>Setting range</b> (min. value   unit   max. value)		<b>Lenze setting</b>	
0.0000	Unit/s	214748.3647	<b>360.0000 Unit/s</b>
<input checked="" type="checkbox"/> Read access		<input checked="" type="checkbox"/> Write access	
<input type="checkbox"/> CINH		<input type="checkbox"/> PLC STOP	
<input type="checkbox"/> No transfer		Scaling factor: 10000	

## C02645

Parameter   Name: <b>C02645   Homing: Acceleration 1</b>		Data type: INTEGER_32 Index: 21930 <sub>d</sub> = 55AA <sub>h</sub>	
▶ Basic function " <a href="#">Homing</a> "			
<b>Setting range</b> (min. value   unit   max. value)		<b>Lenze setting</b>	
0.0000	Unit/s <sup>2</sup>	214748.3647	<b>720.0000 Unit/s<sup>2</sup></b>
<input checked="" type="checkbox"/> Read access		<input checked="" type="checkbox"/> Write access	
<input type="checkbox"/> CINH		<input type="checkbox"/> PLC STOP	
<input type="checkbox"/> No transfer		Scaling factor: 10000	



## C02646

Parameter   Name: <b>C02646   Homing: Speed 2</b>			Data type: INTEGER_32 Index: 21929 <sub>d</sub> = 55A9 <sub>h</sub>
▶ Basic function " <a href="#">Homing</a> "			
<b>Setting range (min. value   unit   max. value)</b>			<b>Lenze setting</b>
0.0000	Unit/s	214748.3647	<b>0.0000 Unit/s</b>
<input checked="" type="checkbox"/> Read access <input checked="" type="checkbox"/> Write access <input type="checkbox"/> CINH <input type="checkbox"/> PLC STOP <input type="checkbox"/> No transfer			Scaling factor: 10000

## C02647

Parameter   Name: <b>C02647   Homing: Acceleration 2</b>			Data type: INTEGER_32 Index: 21928 <sub>d</sub> = 55A8 <sub>h</sub>
▶ Basic function " <a href="#">Homing</a> "			
<b>Setting range (min. value   unit   max. value)</b>			<b>Lenze setting</b>
0.0000	Unit/s <sup>2</sup>	214748.3647	<b>360.0000 Unit/s<sup>2</sup></b>
<input checked="" type="checkbox"/> Read access <input checked="" type="checkbox"/> Write access <input type="checkbox"/> CINH <input type="checkbox"/> PLC STOP <input type="checkbox"/> No transfer			Scaling factor: 10000

## C02648

Parameter   Name: <b>C02648   Homing: S-ramp time</b>			Data type: INTEGER_32 Index: 21927 <sub>d</sub> = 55A7 <sub>h</sub>
▶ Basic function " <a href="#">Homing</a> "			
<b>Setting range (min. value   unit   max. value)</b>			<b>Lenze setting</b>
0	ms	10000	<b>100 ms</b>
<input checked="" type="checkbox"/> Read access <input checked="" type="checkbox"/> Write access <input type="checkbox"/> CINH <input type="checkbox"/> PLC STOP <input type="checkbox"/> No transfer			Scaling factor: 1

## C02649

Parameter   Name: <b>C02649   Homing: Torque limit</b>			Data type: INTEGER_32 Index: 21926 <sub>d</sub> = 55A6 <sub>h</sub>
▶ Basic function " <a href="#">Homing</a> "			
<b>Setting range (min. value   unit   max. value)</b>			<b>Lenze setting</b>
0.00	%	200.00	<b>10.00 %</b>
<input checked="" type="checkbox"/> Read access <input checked="" type="checkbox"/> Write access <input type="checkbox"/> CINH <input type="checkbox"/> PLC STOP <input type="checkbox"/> No transfer			Scaling factor: 100

## C02650

Parameter   Name: <b>C02650   Homing: Blocking time</b>			Data type: UNSIGNED_32 Index: 21925 <sub>d</sub> = 55A5 <sub>h</sub>
▶ Basic function " <a href="#">Homing</a> "			
<b>Setting range (min. value   unit   max. value)</b>			<b>Lenze setting</b>
0.000	s	120.000	<b>1.000 s</b>
<input checked="" type="checkbox"/> Read access <input checked="" type="checkbox"/> Write access <input type="checkbox"/> CINH <input type="checkbox"/> PLC STOP <input type="checkbox"/> No transfer			Scaling factor: 1000

## C02651

Parameter   Name: <b>C02651   Homing: TP configuration</b>		Data type: UNSIGNED_32 Index: 21924 <sub>d</sub> = 55A4 <sub>h</sub>	
▶ Basic function " <a href="#">Homing</a> "			
<b>Setting range</b> (min. value   unit   max. value)		<b>Lenze setting</b>	
0		4294967295	<b>16</b>
<input checked="" type="checkbox"/> Read access <input checked="" type="checkbox"/> Write access <input type="checkbox"/> CINH <input type="checkbox"/> PLC STOP <input type="checkbox"/> No transfer		Scaling factor: 1	

## C02652

Parameter   Name: <b>C02652   Ref. pos. after mains switching</b>		Data type: UNSIGNED_32 Index: 21923 <sub>d</sub> = 55A3 <sub>h</sub>	
▶ Basic function " <a href="#">Homing</a> "			
<b>Selection list</b> (Lenze setting printed in bold)			
0	<b>Delete</b>		
1	Retain		
<input checked="" type="checkbox"/> Read access <input checked="" type="checkbox"/> Write access <input type="checkbox"/> CINH <input type="checkbox"/> PLC STOP <input type="checkbox"/> No transfer		Scaling factor: 1	

## C02653

Parameter   Name: <b>C02653   Max. rot. ang. aft. mns. swtch.</b>		Data type: INTEGER_32 Index: 21922 <sub>d</sub> = 55A2 <sub>h</sub>	
▶ Basic function " <a href="#">Homing</a> "			
<b>Setting range</b> (min. value   unit   max. value)		<b>Lenze setting</b>	
0	°	1000000	<b>180 °</b>
<input checked="" type="checkbox"/> Read access <input checked="" type="checkbox"/> Write access <input type="checkbox"/> CINH <input type="checkbox"/> PLC STOP <input type="checkbox"/> No transfer		Scaling factor: 1	

## C02655

Parameter   Name: <b>C02655   HM_dnSpeedOverride_n</b>		Data type: INTEGER_32 Index: 21920 <sub>d</sub> = 55A0 <sub>h</sub>	
From software version V5.0 Display of the speed override for the basic function " <a href="#">Homing</a> ".			
<b>Display range</b> (min. value   unit   max. value)			
-200.00	%	200.00	
<input checked="" type="checkbox"/> Read access <input type="checkbox"/> Write access <input type="checkbox"/> CINH <input type="checkbox"/> PLC STOP <input type="checkbox"/> No transfer		Scaling factor: 100	

## C02656

Parameter   Name: <b>C02656   Actual position (homing)</b>		Data type: INTEGER_32 Index: 21919 <sub>d</sub> = 559F <sub>h</sub>	
▶ Basic function " <a href="#">Homing</a> "			
<b>Display range</b> (min. value   unit   max. value)			
-214748.3647	Unit	214748.3647	
<input checked="" type="checkbox"/> Read access <input type="checkbox"/> Write access <input type="checkbox"/> CINH <input type="checkbox"/> PLC STOP <input type="checkbox"/> No transfer		Scaling factor: 10000	

## C02657

Parameter   Name: <b>C02657   HM_dnState</b>		Data type: INTEGER_32 Index: 21918 <sub>d</sub> = 559E <sub>h</sub>
Bit coded status of the basic function " <a href="#">Homing</a> ".		
<b>Display range (min. value   unit   max. value)</b>		
-2147483648		2147483647
<input checked="" type="checkbox"/> Read access <input type="checkbox"/> Write access <input type="checkbox"/> CINH <input type="checkbox"/> PLC STOP <input type="checkbox"/> No transfer		Scaling factor: 1

## C02658

Parameter   Name: <b>C02658   HM_dnHomePos_p</b>		Data type: INTEGER_32 Index: 21917 <sub>d</sub> = 559D <sub>h</sub>
Display of the <i>HM_dnHomePos_p</i> input signal of the basic function " <a href="#">Homing</a> ".		
<b>Display range (min. value   unit   max. value)</b>		
-214748.3647		214748.3647
<input checked="" type="checkbox"/> Read access <input type="checkbox"/> Write access <input type="checkbox"/> CINH <input type="checkbox"/> PLC STOP <input type="checkbox"/> No transfer		Scaling factor: 10000

## C02659

Parameter   Name: <b>C02659   Homing: Dig. signals</b>		Data type: UNSIGNED_32 Index: 21916 <sub>d</sub> = 559C <sub>h</sub>
Display of the digital signals of the basic function " <a href="#">Homing</a> ".		
<b>Selection list (read only)</b>		
0	FALSE	
1	TRUE	
<b>Subcodes</b>	<b>Info</b>	
C02659/1	HM_bEnable	
C02659/2	HM_bActivateHoming	
C02659/3	HM_bHomingMark	
C02659/4	HM_bLoadHomePos	
C02659/5	HM_bResetHomePos	
C02659/6	HM_bEnabled	
C02659/7	HM_bActive	
C02659/8	HM_bDone	
C02659/9	HM_bHomePosAvailable	
<input checked="" type="checkbox"/> Read access <input type="checkbox"/> Write access <input type="checkbox"/> CINH <input type="checkbox"/> PLC STOP <input type="checkbox"/> No transfer		Scaling factor: 1

## C02670

Parameter   Name: <b>C02670   Tolerance for POS_bActPosInTarget</b>		Data type: INTEGER_32 Index: 21905 <sub>d</sub> = 5591 <sub>h</sub>
From software version V1.5 Tolerance window for actual value-based evaluation "Target position reached" (Output <i>POS_bActPosInTarget</i> )		
▶ Basic function " <a href="#">Positioning</a> "		
<b>Setting range (min. value   unit   max. value)</b>		<b>Lenze setting</b>
0.0000	Unit	214748.3647
		<b>0.0000 Unit</b>
<input checked="" type="checkbox"/> Read access <input checked="" type="checkbox"/> Write access <input type="checkbox"/> CINH <input type="checkbox"/> PLC STOP <input type="checkbox"/> No transfer		Scaling factor: 10000

## C02671

Parameter   Name: <b>C02671   Tolerance for POS_bDriveInTarget</b>		Data type: INTEGER_32 Index: 21904 <sub>d</sub> = 5590 <sub>h</sub>	
From software version V5.0 Tolerance window for actual value and setpoint-based evaluation "Drive in the target" (Output POS_bDriveInTarget) <p style="text-align: right;">▶ Basic function "<a href="#">Positioning</a>"</p>			
<b>Setting range</b> (min. value   unit   max. value)		<b>Lenze setting</b>	
0.0001	Unit	214748.3647	<b>2.0000 Unit</b>
<input checked="" type="checkbox"/> Read access <input checked="" type="checkbox"/> Write access <input type="checkbox"/> CINH <input type="checkbox"/> PLC STOP <input type="checkbox"/> No transfer		Scaling factor: 10000	

## C02672

Parameter   Name: <b>C02672   Hysteresis for POS_bDriveInTarget</b>		Data type: INTEGER_32 Index: 21903 <sub>d</sub> = 558F <sub>h</sub>	
From software version V5.0 Hysteresis window for actual value and setpoint-based evaluation "Drive in the target" (Output POS_bDriveInTarget) <p style="text-align: right;">▶ Basic function "<a href="#">Positioning</a>"</p>			
<b>Setting range</b> (min. value   unit   max. value)		<b>Lenze setting</b>	
0.0000	Unit	214748.3647	<b>1.0000 Unit</b>
<input checked="" type="checkbox"/> Read access <input checked="" type="checkbox"/> Write access <input type="checkbox"/> CINH <input type="checkbox"/> PLC STOP <input type="checkbox"/> No transfer		Scaling factor: 10000	

## C02673

Parameter   Name: <b>C02673   Activate DriveInTarget Modulo</b>		Data type: UNSIGNED_32 Index: 21902 <sub>d</sub> = 558E <sub>h</sub>	
From software version V5.0 For actual value and setpoint-based evaluation "Drive in target" (output POS_bDriveInTarget): Definition how the modulo evaluation is to be carried out if the actual position value enters the tolerance and hysteresis window again. <p style="text-align: right;">▶ Basic function "<a href="#">Positioning</a>"</p>			
<b>Selection list</b> (Lenze setting printed in bold)			
0	Only setpoint Cycle		
<b>1</b>	<b>All cycles</b>		
<input checked="" type="checkbox"/> Read access <input checked="" type="checkbox"/> Write access <input type="checkbox"/> CINH <input type="checkbox"/> PLC STOP <input type="checkbox"/> No transfer		Scaling factor: 1	

## C02674

Parameter   Name: <b>C02674   POS_dwActualProfileNumber</b>		Data type: UNSIGNED_32 Index: 21901 <sub>d</sub> = 558D <sub>h</sub>	
Current profile of the basic function " <a href="#">Positioning</a> ".			
<b>Display range</b> (min. value   unit   max. value)			
0		1000	
<input checked="" type="checkbox"/> Read access <input type="checkbox"/> Write access <input type="checkbox"/> CINH <input type="checkbox"/> PLC STOP <input type="checkbox"/> No transfer		Scaling factor: 1	

## C02675

Parameter   Name: <b>C02675   POS_dnState</b>		Data type: INTEGER_32 Index: 21900 <sub>d</sub> = 558C <sub>h</sub>
Bit coded status of the basic function " <a href="#">Positioning</a> ".		
<b>Display range (min. value   unit   max. value)</b>		
-2147483648		2147483647
<input checked="" type="checkbox"/> Read access <input type="checkbox"/> Write access <input type="checkbox"/> CINH <input type="checkbox"/> PLC STOP <input type="checkbox"/> No transfer		Scaling factor: 1

## C02676

Parameter   Name: <b>C02676   POS_dnProfileSpeed_s</b>		Data type: INTEGER_32 Index: 21899 <sub>d</sub> = 558B <sub>h</sub>
Display of the max. speed of the current profile of the basic function " <a href="#">Positioning</a> ".		
<b>Display range (min. value   unit   max. value)</b>		
-214748.3647		214748.3647
<input checked="" type="checkbox"/> Read access <input type="checkbox"/> Write access <input type="checkbox"/> CINH <input type="checkbox"/> PLC STOP <input type="checkbox"/> No transfer		Scaling factor: 10000

## C02677

Parameter   Name: <b>C02677   Positioning: % signals</b>		Data type: INTEGER_32 Index: 21898 <sub>d</sub> = 558A <sub>h</sub>
Display of the scaled signals of the basic function " <a href="#">Positioning</a> ".		
<b>Display range (min. value   unit   max. value)</b>		
-200.00	%	200.00
<b>Subcodes</b>		<b>Info</b>
C02677/1		POS_dnSpeedOverride_n
C02677/2		POS_dnAccOverride_n
C02677/3		POS_dnDecOverride_n
<input checked="" type="checkbox"/> Read access <input type="checkbox"/> Write access <input type="checkbox"/> CINH <input type="checkbox"/> PLC STOP <input type="checkbox"/> No transfer		Scaling factor: 100

## C02678

Parameter   Name: <b>C02678   Positioning: Pos. signals</b>		Data type: INTEGER_32 Index: 21897 <sub>d</sub> = 5589 <sub>h</sub>
Display of the position signals of the basic function " <a href="#">Positioning</a> ".		
<b>Display range (min. value   unit   max. value)</b>		
-214748.3647	Unit	214748.3647
<b>Subcodes</b>		<b>Info</b>
C02678/1		POS_dnSetPos_p
C02678/2		POS_dnProfileTarget_p
C02678/3		POS_dnActPosRelative_p
C02678/4		POS_dnSetPosRelative_p
<input checked="" type="checkbox"/> Read access <input type="checkbox"/> Write access <input type="checkbox"/> CINH <input type="checkbox"/> PLC STOP <input type="checkbox"/> No transfer		Scaling factor: 10000

## C02679

Parameter   Name: C02679   Positioning: Dig. signals		Data type: UNSIGNED_32 Index: 21896 <sub>d</sub> = 5588 <sub>h</sub>
Display of the digital signals of the basic function " <a href="#">Positioning</a> ".		
Selection list (read only)		
0	FALSE	
1	TRUE	
Subcodes	Info	
C02679/1	POS_bEnable	
C02679/2	POS_bStart	
C02679/3	POS_bAbort	
C02679/4	POS_bRestart	
C02679/5	POS_bEnableOverride	
C02679/6	POS_bDisableTP	
C02679/7	POS_bEnabled	
C02679/8	POS_bActive	
C02679/9	POS_bDone	
C02679/10	POS_bInTarget	
C02679/11	POS_bActPosInTarget	
C02679/12	POS_bDrivelnTarget	
<input checked="" type="checkbox"/> Read access <input type="checkbox"/> Write access <input type="checkbox"/> CINH <input type="checkbox"/> PLC STOP <input type="checkbox"/> No transfer		Scaling factor: 1

## C02680

Parameter   Name: C02680   Source position setpoint		Data type: UNSIGNED_32 Index: 21895 <sub>d</sub> = 5587 <sub>h</sub>
▶ Basic function " <a href="#">Positioning</a> "		
Selection list (Lenze setting printed in bold)		
0	<b>Position setpoint input</b>	
1	From add. speed	
<input checked="" type="checkbox"/> Read access <input checked="" type="checkbox"/> Write access <input type="checkbox"/> CINH <input type="checkbox"/> PLC STOP <input type="checkbox"/> No transfer		Scaling factor: 1

## C02681

Parameter   Name: C02681   Source add. speed		Data type: UNSIGNED_32 Index: 21894 <sub>d</sub> = 5586 <sub>h</sub>
▶ Basic function " <a href="#">Positioning</a> "		
Selection list (Lenze setting printed in bold)		
0	<b>Add. speed input</b>	
1	From position setpoint	
<input checked="" type="checkbox"/> Read access <input checked="" type="checkbox"/> Write access <input type="checkbox"/> CINH <input type="checkbox"/> PLC STOP <input type="checkbox"/> No transfer		Scaling factor: 1

## C02685

Parameter   Name: <b>C02685   PF_dnMotorAcc_x</b>		Data type: INTEGER_32 Index: 21890 <sub>d</sub> = 5582 <sub>h</sub>
Display of the motor acceleration of the basic function " <a href="#">Position follower</a> ".		
<b>Display range (min. value   unit   max. value)</b>		
-7680000.0		7680000.0
<input checked="" type="checkbox"/> Read access <input type="checkbox"/> Write access <input type="checkbox"/> CINH <input type="checkbox"/> PLC STOP <input type="checkbox"/> No transfer		Scaling factor: 10

## C02686

Parameter   Name: <b>C02686   PF_dnSpeedAdd1_s</b>		Data type: INTEGER_32 Index: 21889 <sub>d</sub> = 5581 <sub>h</sub>
Display of the speed feedforward control value of the basic function " <a href="#">Position follower</a> ".		
<b>Display range (min. value   unit   max. value)</b>		
-480000.0	rpm	480000.0
<input checked="" type="checkbox"/> Read access <input type="checkbox"/> Write access <input type="checkbox"/> CINH <input type="checkbox"/> PLC STOP <input type="checkbox"/> No transfer		Scaling factor: 10

## C02687

Parameter   Name: <b>C02687   Position follower: % signals</b>		Data type: INTEGER_32 Index: 21888 <sub>d</sub> = 5580 <sub>h</sub>
Display of the scaled signals of the basic function " <a href="#">Position follower</a> ".		
<b>Display range (min. value   unit   max. value)</b>		
-200.00	%	200.00
<b>Subcodes</b>		<b>Info</b>
C02687/1		PF_dnSpeedAdd2_n
C02687/2		PF_dnTorqueAdd_n
<input checked="" type="checkbox"/> Read access <input type="checkbox"/> Write access <input type="checkbox"/> CINH <input type="checkbox"/> PLC STOP <input type="checkbox"/> No transfer		Scaling factor: 100

## C02688

Parameter   Name: <b>C02688   PF_dnPositionSet_p</b>		Data type: INTEGER_32 Index: 21887 <sub>d</sub> = 557F <sub>h</sub>
Display of the position signals of the basic function " <a href="#">Position follower</a> ".		
<b>Display range (min. value   unit   max. value)</b>		
-214748.3648	Revolution	214748.3647
<input checked="" type="checkbox"/> Read access <input type="checkbox"/> Write access <input type="checkbox"/> CINH <input type="checkbox"/> PLC STOP <input type="checkbox"/> No transfer		Scaling factor: 10000

## C02689

Parameter   Name: <b>C02689   Position follower: Dig. signals</b>		Data type: UNSIGNED_32 Index: 21886 <sub>d</sub> = 557E <sub>h</sub>
Display of the digital signals of the basic function " <a href="#">Position follower</a> ".		
<b>Selection list (read only)</b>		
0	FALSE	
1	TRUE	
<b>Subcodes</b>		<b>Info</b>
C02689/1		PF_bEnable
C02689/2		PF_bEnabled
<input checked="" type="checkbox"/> Read access <input type="checkbox"/> Write access <input type="checkbox"/> CINH <input type="checkbox"/> PLC STOP <input type="checkbox"/> No transfer		Scaling factor: 1

## C02692

Parameter   Name: <b>C02692   SF_dnMotorAcc_x</b>		Data type: INTEGER_32 Index: 21883 <sub>d</sub> = 557B <sub>h</sub>
Display of the motor acceleration of the basic function " <a href="#">Speed follower</a> ".		
<b>Display range (min. value   unit   max. value)</b>		
-7680000.0		7680000.0
<input checked="" type="checkbox"/> Read access <input type="checkbox"/> Write access <input type="checkbox"/> CINH <input type="checkbox"/> PLC STOP <input type="checkbox"/> No transfer		Scaling factor: 10

## C02693

Parameter   Name: <b>C02693   SF_dnSpeedAdd_s</b>		Data type: INTEGER_32 Index: 21882 <sub>d</sub> = 557A <sub>h</sub>
Display of the additive speed setpoint of the basic function " <a href="#">Speed follower</a> ".		
<b>Display range (min. value   unit   max. value)</b>		
-480000.0	rpm	480000.0
<input checked="" type="checkbox"/> Read access <input type="checkbox"/> Write access <input type="checkbox"/> CINH <input type="checkbox"/> PLC STOP <input type="checkbox"/> No transfer		Scaling factor: 10

## C02694

Parameter   Name: <b>C02694   Speed follower: % signals</b>		Data type: INTEGER_32 Index: 21881 <sub>d</sub> = 5579 <sub>h</sub>
Display of the scaled signals of the basic function " <a href="#">Speed follower</a> ".		
<b>Display range (min. value   unit   max. value)</b>		
-200.00	%	200.00
<b>Subcodes</b>		<b>Info</b>
C02694/1		SF_dnSpeedSet_n
C02694/2		SF_dnTorqueAdd_n
<input checked="" type="checkbox"/> Read access <input type="checkbox"/> Write access <input type="checkbox"/> CINH <input type="checkbox"/> PLC STOP <input type="checkbox"/> No transfer		Scaling factor: 100

## C02695

Parameter   Name: <b>C02695   Speed follower: Dig. signals</b>		Data type: UNSIGNED_32 Index: 21880 <sub>d</sub> = 5578 <sub>h</sub>
Display of the digital signals of the basic function " <a href="#">Speed follower</a> ".		
<b>Selection list (read only)</b>		
0	FALSE	
1	TRUE	
<b>Subcodes</b>		<b>Info</b>
C02695/1		SF_bEnable
C02695/2		SF_bEnabled
<input checked="" type="checkbox"/> Read access <input type="checkbox"/> Write access <input type="checkbox"/> CINH <input type="checkbox"/> PLC STOP <input type="checkbox"/> No transfer		Scaling factor: 1



## C02698

Parameter   Name: <b>C02698   Torque follower: % signals</b>		Data type: INTEGER_32 Index: 21877 <sub>d</sub> = 5575 <sub>h</sub>
Display of the scaled signals of the basic function " <a href="#">Torque follower</a> ".		
<b>Display range</b> (min. value   unit   max. value)		
-200.00	%	200.00
<b>Subcodes</b>		<b>Info</b>
C02698/1		TF_TorqueSet_n
C02698/2		TF_dnSpeedHighLimit_n
C02698/3		TF_dnSpeedLowLimit_n
<input checked="" type="checkbox"/> Read access <input type="checkbox"/> Write access <input type="checkbox"/> CINH <input type="checkbox"/> PLC STOP <input type="checkbox"/> No transfer		Scaling factor: 100

## C02699

Parameter   Name: <b>C02699   Torque follower: Dig. signals</b>		Data type: UNSIGNED_32 Index: 21876 <sub>d</sub> = 5574 <sub>h</sub>
Display of the digital signals of the basic function " <a href="#">Torque follower</a> ".		
<b>Selection list</b> (read only)		
0	FALSE	
1	TRUE	
<b>Subcodes</b>		<b>Info</b>
C02699/1		TF_bEnable
C02699/2		TF_bEnabled
<input checked="" type="checkbox"/> Read access <input type="checkbox"/> Write access <input type="checkbox"/> CINH <input type="checkbox"/> PLC STOP <input type="checkbox"/> No transfer		Scaling factor: 1

## C02700

Parameter   Name: <b>C02700   Software limits pos. effective</b>		Data type: UNSIGNED_32 Index: 21875 <sub>d</sub> = 5573 <sub>h</sub>
▶ Basic function " <a href="#">"Limiter"</a> "		
<b>Selection list</b> (Lenze setting printed in bold)		
0	<b>Deactivated</b>	
1	enabled	
<input checked="" type="checkbox"/> Read access <input checked="" type="checkbox"/> Write access <input type="checkbox"/> CINH <input type="checkbox"/> PLC STOP <input type="checkbox"/> No transfer		Scaling factor: 1

## C02701

Parameter   Name: <b>C02701   Software limit positions</b>		Data type: INTEGER_32 Index: 21874 <sub>d</sub> = 5572 <sub>h</sub>
▶ Basic function " <a href="#">"Limiter"</a> "		
<b>Setting range</b> (min. value   unit   max. value)		
-214748.3647	Unit	214748.3647
<b>Subcodes</b>		<b>Info</b>
C02701/1	0.0000 Unit	Positive software limit position
C02701/2	0.0000 Unit	Negative software limit position
<input checked="" type="checkbox"/> Read access <input checked="" type="checkbox"/> Write access <input type="checkbox"/> CINH <input type="checkbox"/> PLC STOP <input type="checkbox"/> No transfer		Scaling factor: 10000

## C02702

Parameter   Name: <b>C02702   Limitations effective</b>		Data type: UNSIGNED_32 Index: 21873 <sub>d</sub> = 5571 <sub>h</sub>	
▶ Basic function " <a href="#">"Limiter"</a> "			
<b>Selection list</b> (Lenze setting printed in bold)			
0	<b>Deactivated</b>		
1	enabled		
<input checked="" type="checkbox"/> Read access		<input checked="" type="checkbox"/> Write access	
<input type="checkbox"/> CINH		<input type="checkbox"/> PLC STOP	
<input type="checkbox"/> No transfer		Scaling factor: 1	

## C02703

Parameter   Name: <b>C02703   Max. speed</b>		Data type: INTEGER_32 Index: 21872 <sub>d</sub> = 5570 <sub>h</sub>	
▶ Basic function " <a href="#">"Limiter"</a> "			
<b>Setting range</b> (min. value   unit   max. value)		<b>Lenze setting</b>	
0.0000	Unit/s	214748.3647	<b>3600.0000 Unit/s</b>
<input checked="" type="checkbox"/> Read access		<input checked="" type="checkbox"/> Write access	
<input type="checkbox"/> CINH		<input type="checkbox"/> PLC STOP	
<input type="checkbox"/> No transfer		Scaling factor: 10000	

## C02704

Parameter   Name: <b>C02704   Max. speed [rpm]</b>		Data type: INTEGER_32 Index: 21871 <sub>d</sub> = 556F <sub>h</sub>	
▶ Basic function " <a href="#">"Limiter"</a> "			
<b>Display range</b> (min. value   unit   max. value)			
0.0	rpm	214748364.7	
<input checked="" type="checkbox"/> Read access		<input type="checkbox"/> Write access	
<input type="checkbox"/> CINH		<input type="checkbox"/> PLC STOP	
<input type="checkbox"/> No transfer		Scaling factor: 10	

## C02705

Parameter   Name: <b>C02705   Max. acceleration</b>		Data type: INTEGER_32 Index: 21870 <sub>d</sub> = 556E <sub>h</sub>	
▶ Basic function " <a href="#">"Limiter"</a> "			
<b>Setting range</b> (min. value   unit   max. value)		<b>Lenze setting</b>	
0.0000	Unit/s <sup>2</sup>	214748.3647	<b>3600.0000 Unit/s<sup>2</sup></b>
<input checked="" type="checkbox"/> Read access		<input checked="" type="checkbox"/> Write access	
<input type="checkbox"/> CINH		<input type="checkbox"/> PLC STOP	
<input type="checkbox"/> No transfer		Scaling factor: 10000	

## C02706

Parameter   Name: <b>C02706   Min. S-ramp time</b>		Data type: UNSIGNED_32 Index: 21869 <sub>d</sub> = 556D <sub>h</sub>	
▶ Basic function " <a href="#">"Limiter"</a> "			
<b>Setting range</b> (min. value   unit   max. value)		<b>Lenze setting</b>	
0	ms	10000	<b>100 ms</b>
<input checked="" type="checkbox"/> Read access		<input checked="" type="checkbox"/> Write access	
<input type="checkbox"/> CINH		<input type="checkbox"/> PLC STOP	
<input type="checkbox"/> No transfer		Scaling factor: 1	

## C02707

Parameter   Name: <b>C02707   Permissible direction of rot.</b>		Data type: UNSIGNED_32 Index: 21868 <sub>d</sub> = 556C <sub>h</sub>
		▶ Basic function " <a href="#">Limiter</a> "
<b>Selection list</b> (Lenze setting printed in bold)		
<b>0</b>	<b>Positive and negative</b>	
1	Positive only	
2	Negative only	
<input checked="" type="checkbox"/> Read access <input checked="" type="checkbox"/> Write access <input type="checkbox"/> CINH <input type="checkbox"/> PLC STOP <input type="checkbox"/> No transfer		Scaling factor: 1

## C02708

Parameter   Name: <b>C02708   Limited speed</b>		Data type: INTEGER_32 Index: 21867 <sub>d</sub> = 556B <sub>h</sub>
		▶ Basic function " <a href="#">Limiter</a> "
<b>Setting range</b> (min. value   unit   max. value)		
0.0000	Unit/s	214748.3647
<b>Subcodes</b>		<b>Info</b>
C02708/1	3600.0000 Unit/s	Limited speed 1 ... 4
C02708/2	7200.0000 Unit/s	
C02708/3	14400.0000 Unit/s	
C02708/4	28800.0000 Unit/s	
<input checked="" type="checkbox"/> Read access <input checked="" type="checkbox"/> Write access <input type="checkbox"/> CINH <input type="checkbox"/> PLC STOP <input type="checkbox"/> No transfer		Scaling factor: 10000

## C02709

Parameter   Name: <b>C02709   Limited speed [rpm]</b>		Data type: INTEGER_32 Index: 21866 <sub>d</sub> = 556A <sub>h</sub>
		▶ Basic function " <a href="#">Limiter</a> "
<b>Display range</b> (min. value   unit   max. value)		
0.0	rpm	214748364.7
<b>Subcodes</b>		<b>Info</b>
C02709/1		Limited speed 1 ... 4
C02709/2		
C02709/3		
C02709/4		
<input checked="" type="checkbox"/> Read access <input type="checkbox"/> Write access <input type="checkbox"/> CINH <input type="checkbox"/> PLC STOP <input type="checkbox"/> No transfer		Scaling factor: 10

## C02710

Parameter   Name: <b>C02710   Delay lim. speed</b>		Data type: UNSIGNED_32 Index: 21865 <sub>d</sub> = 5569 <sub>h</sub>	
▶ Basic function " <a href="#">"Limiter"</a> "			
<b>Setting range (min. value   unit   max. value)</b>			
0.0000	Unit/s <sup>2</sup>	214748.3647	
<b>Subcodes</b>	<b>Lenze setting</b>	<b>Info</b>	
C02710/1	0.0100 Unit/s <sup>2</sup>	Delays for limited speed 1 ... 4	
C02710/2	0.0100 Unit/s <sup>2</sup>		
C02710/3	0.0100 Unit/s <sup>2</sup>		
C02710/4	0.0100 Unit/s <sup>2</sup>		
<input checked="" type="checkbox"/> Read access		<input checked="" type="checkbox"/> Write access	
<input type="checkbox"/> CINH		<input type="checkbox"/> PLC STOP	
<input type="checkbox"/> No transfer		Scaling factor: 10000	

## C02711

Parameter   Name: <b>C02711   S-ramp time lim. speed</b>		Data type: UNSIGNED_32 Index: 21864 <sub>d</sub> = 5568 <sub>h</sub>	
▶ Basic function " <a href="#">"Limiter"</a> "			
<b>Setting range (min. value   unit   max. value)</b>			
0	ms	10000	
<b>Subcodes</b>	<b>Lenze setting</b>	<b>Info</b>	
C02711/1	100 ms	S-ramp times for limited speed 1 ... 4	
C02711/2	100 ms		
C02711/3	100 ms		
C02711/4	100 ms		
<input checked="" type="checkbox"/> Read access		<input checked="" type="checkbox"/> Write access	
<input type="checkbox"/> CINH		<input type="checkbox"/> PLC STOP	
<input type="checkbox"/> No transfer		Scaling factor: 1	

## C02712

Parameter   Name: <b>C02712   Decel. time lim. speed</b>		Data type: UNSIGNED_32 Index: 21863 <sub>d</sub> = 5567 <sub>h</sub>	
▶ Basic function " <a href="#">"Limiter"</a> "			
<b>Display range (min. value   unit   max. value)</b>			
0	ms	10000	
<b>Subcodes</b>		<b>Info</b>	
C02712/1		Deceleration times for limited speed 1 ... 4	
C02712/2			
C02712/3			
C02712/4			
<input checked="" type="checkbox"/> Read access		<input type="checkbox"/> Write access	
<input type="checkbox"/> CINH		<input type="checkbox"/> PLC STOP	
<input type="checkbox"/> No transfer		Scaling factor: 1	

## C02713

Parameter   Name: <b>C02713   Max. dist. manual control</b>		Data type: UNSIGNED_32 Index: 21862 <sub>d</sub> = 5566 <sub>h</sub>	
▶ Basic function " <a href="#">"Limiter"</a> "			
<b>Setting range (min. value   unit   max. value)</b>		<b>Lenze setting</b>	
0.0000	Unit	214748.3647	<b>360.0000 Unit</b>
<input checked="" type="checkbox"/> Read access		<input checked="" type="checkbox"/> Write access	
<input type="checkbox"/> CINH		<input type="checkbox"/> PLC STOP	
<input type="checkbox"/> No transfer		Scaling factor: 10000	

## C02714

Parameter   Name: <b>C02714   Max. dist. manual jog [inc.]</b>		Data type: UNSIGNED_32 Index: 21861 <sub>d</sub> = 5565 <sub>h</sub>
▶ Basic function " <a href="#">"Limiter"</a> "		
<b>Display range (min. value   unit   max. value)</b>		
0	Incr.	2147483647
<input checked="" type="checkbox"/> Read access <input type="checkbox"/> Write access <input type="checkbox"/> CINH <input type="checkbox"/> PLC STOP <input type="checkbox"/> No transfer           Scaling factor: 1		

## C02715

Parameter   Name: <b>C02715   Limitation active</b>		Data type: UNSIGNED_32 Index: 21860 <sub>d</sub> = 5564 <sub>h</sub>
▶ Basic function " <a href="#">"Limiter"</a> "		
<b>Selection list (read only)</b>		
0	Deactivated	
1	enabled	
<input checked="" type="checkbox"/> Read access <input type="checkbox"/> Write access <input type="checkbox"/> CINH <input type="checkbox"/> PLC STOP <input type="checkbox"/> No transfer           Scaling factor: 1		

## C02716

Parameter   Name: <b>C02716   Resp. to limitation</b>		Data type: UNSIGNED_32 Index: 21859 <sub>d</sub> = 5563 <sub>h</sub>
▶ Basic function " <a href="#">"Limiter"</a> "		
<b>Selection list</b>		
1	Error	
2	Fault	
3	Quick stop by trouble	
4	Warning locked	
5	Warning	
6	Information	
0	No response	
<b>Subcodes</b>	<b>Lenze setting</b>	<b>Info</b>
C02716/1	6: Information	Resp. to rotation limitation
C02716/2	3: Quick stop by trouble	Resp. to SW lim. pos. exceeded
C02716/3	6: Information	Resp. to max. value exceeded
<input checked="" type="checkbox"/> Read access <input checked="" type="checkbox"/> Write access <input type="checkbox"/> CINH <input type="checkbox"/> PLC STOP <input type="checkbox"/> No transfer           Scaling factor: 1		

## C02717

Parameter   Name: <b>C02717   LIM_dwControl</b>		Data type: UNSIGNED_32 Index: 21858 <sub>d</sub> = 5562 <sub>h</sub>
Bit coded control word of the basic function " <a href="#">"Limiter"</a> ".		
<b>Display range (min. value   unit   max. value)</b>		
0		4294967295
<input checked="" type="checkbox"/> Read access <input type="checkbox"/> Write access <input type="checkbox"/> CINH <input type="checkbox"/> PLC STOP <input type="checkbox"/> No transfer           Scaling factor: 1		

## C02718

Parameter   Name: <b>C02718   LIM_dnState</b>		Data type: INTEGER_32 Index: 21857 <sub>d</sub> = 5561 <sub>h</sub>
Status of the basic function " <a href="#">Limiter</a> ".		
<b>Display range (min. value   unit   max. value)</b>		
0		1
<input checked="" type="checkbox"/> Read access <input type="checkbox"/> Write access <input type="checkbox"/> CINH <input type="checkbox"/> PLC STOP <input type="checkbox"/> No transfer		Scaling factor: 1

## C02719

Parameter   Name: <b>C02719   Limiter: Dig. signals</b>		Data type: UNSIGNED_32 Index: 21856 <sub>d</sub> = 5560 <sub>h</sub>
Display of the digital input signals of the basic function " <a href="#">Limiter</a> ".		
<b>Selection list (read only)</b>		
0	FALSE	
1	TRUE	
<b>Subcodes</b>		<b>Info</b>
C02719/1	LIM_bLimitSwitchPositive	
C02719/2	LIM_bLimitSwitchNegative	
C02719/3	LIM_bActivateLimitedSpeed1	
<input checked="" type="checkbox"/> Read access <input type="checkbox"/> Write access <input type="checkbox"/> CINH <input type="checkbox"/> PLC STOP <input type="checkbox"/> No transfer		Scaling factor: 1

## C02720

Parameter   Name: <b>C02720   observation software limit positions</b>		Data type: UNSIGNED_32 Index: 21855 <sub>d</sub> = 555F <sub>h</sub>
From software version V4.0		► Basic function " <a href="#">Limiter</a> "
<b>Selection list (Lenze setting printed in bold)</b>		
0	<b>Based on set value</b>	
1	Based on set and actual value	
<input checked="" type="checkbox"/> Read access <input checked="" type="checkbox"/> Write access <input type="checkbox"/> CINH <input type="checkbox"/> PLC STOP <input type="checkbox"/> No transfer		Scaling factor: 1

## C02730

Parameter   Name: <b>C02730   Analog inputs: Gain</b>		Data type: INTEGER_32 Index: 21845 <sub>d</sub> = 5555 <sub>h</sub>
<b>Setting range (min. value   unit   max. value)</b>		
-200.00	%	200.00
<b>Subcodes</b>		<b>Info</b>
C02730/1	100.00 %	Gain - analog input 1
C02730/2	100.00 %	Analog input 2: Gain
<input checked="" type="checkbox"/> Read access <input checked="" type="checkbox"/> Write access <input type="checkbox"/> CINH <input type="checkbox"/> PLC STOP <input type="checkbox"/> No transfer		Scaling factor: 100

## C02731

Parameter   Name: C02731   Analog inputs: Offset			Data type: INTEGER_32 Index: 21844 <sub>d</sub> = 5554 <sub>h</sub>
<b>Setting range (min. value   unit   max. value)</b>			
-200.00	%	200.00	
Subcodes	Lenze setting	Info	
C02731/1	0.00 %	Offset - analog input 1	
C02731/2	0.00 %	Analog input 2: Offset	
<input checked="" type="checkbox"/> Read access <input checked="" type="checkbox"/> Write access <input type="checkbox"/> CINH <input type="checkbox"/> PLC STOP <input type="checkbox"/> No transfer			Scaling factor: 100

## C02732

Parameter   Name: C02732   Analog inputs: Dead band			Data type: INTEGER_32 Index: 21843 <sub>d</sub> = 5553 <sub>h</sub>
<b>Setting range (min. value   unit   max. value)</b>			
0.00	%	100.00	
Subcodes	Lenze setting	Info	
C02732/1	0.00 %	Dead band - analog input 1	
C02732/2	0.00 %	Analog input 2: Dead band	
<input checked="" type="checkbox"/> Read access <input checked="" type="checkbox"/> Write access <input type="checkbox"/> CINH <input type="checkbox"/> PLC STOP <input type="checkbox"/> No transfer			Scaling factor: 100

## C02733

Parameter   Name: C02733   Analog outputs: Gain			Data type: INTEGER_32 Index: 21842 <sub>d</sub> = 5552 <sub>h</sub>
<b>Setting range (min. value   unit   max. value)</b>			
-200.00	%	200.00	
Subcodes	Lenze setting	Info	
C02733/1	100.00 %	Gain - analog output 1	
C02733/2	100.00 %	Analog output 2: Gain	
<input checked="" type="checkbox"/> Read access <input checked="" type="checkbox"/> Write access <input type="checkbox"/> CINH <input type="checkbox"/> PLC STOP <input type="checkbox"/> No transfer			Scaling factor: 100

## C02734

Parameter   Name: C02734   Analog outputs: Offset			Data type: INTEGER_32 Index: 21841 <sub>d</sub> = 5551 <sub>h</sub>
<b>Setting range (min. value   unit   max. value)</b>			
-200.00	%	200.00	
Subcodes	Lenze setting	Info	
C02734/1	0.00 %	Offset - analog output 1	
C02734/2	0.00 %	Analog output 2: Offset	
<input checked="" type="checkbox"/> Read access <input checked="" type="checkbox"/> Write access <input type="checkbox"/> CINH <input type="checkbox"/> PLC STOP <input type="checkbox"/> No transfer			Scaling factor: 100

## C02760

Parameter   Name: <b>C02760   Activate encoder</b>		Data type: UNSIGNED_32 Index: 21815 <sub>d</sub> = 5537 <sub>h</sub>
From software version V7.0		
▶ Encoder evaluation: <a href="#">Provision of the encoder signal of input X8</a>		
<b>Selection list</b> (Lenze setting printed in bold)		
<b>0</b>	<b>Deactivated</b>	
1	enabled	
<input checked="" type="checkbox"/> Read access <input checked="" type="checkbox"/> Write access <input type="checkbox"/> CINH <input type="checkbox"/> PLC STOP <input type="checkbox"/> No transfer		Scaling factor: 1

## C02761

Parameter   Name: <b>C02761   Multiturn resolution</b>		Data type: UNSIGNED_32 Index: 21814 <sub>d</sub> = 5536 <sub>h</sub>
From software version V7.0		
▶ Encoder evaluation: <a href="#">Provision of the encoder signal of input X8</a>		
<b>Display range</b> (min. value   unit   max. value)		
0	Rev.	2147483647
<input checked="" type="checkbox"/> Read access <input type="checkbox"/> Write access <input type="checkbox"/> CINH <input type="checkbox"/> PLC STOP <input type="checkbox"/> No transfer		Scaling factor: 1

## C02762

Parameter   Name: <b>C02762   Encoderpos</b>		Data type: INTEGER_32 Index: 21813 <sub>d</sub> = 5535 <sub>h</sub>
From software version V7.0		
▶ Encoder evaluation: <a href="#">Provision of the encoder signal of input X8</a>		
<b>Display range</b> (min. value   unit   max. value)		
-2147483647	Steps	2147483647
<input checked="" type="checkbox"/> Read access <input type="checkbox"/> Write access <input type="checkbox"/> CINH <input type="checkbox"/> PLC STOP <input type="checkbox"/> No transfer		Scaling factor: 1

## C02763

Parameter   Name: <b>C02763   Encoderrev</b>		Data type: INTEGER_32 Index: 21812 <sub>d</sub> = 5534 <sub>h</sub>
From software version V7.0		
▶ Encoder evaluation: <a href="#">Provision of the encoder signal of input X8</a>		
<b>Display range</b> (min. value   unit   max. value)		
-2147483647	Steps	2147483647
<input checked="" type="checkbox"/> Read access <input type="checkbox"/> Write access <input type="checkbox"/> CINH <input type="checkbox"/> PLC STOP <input type="checkbox"/> No transfer		Scaling factor: 1

## C02764

Parameter   Name: <b>C02764   Encoderspeed</b>		Data type: INTEGER_32 Index: 21811 <sub>d</sub> = 5533 <sub>h</sub>
From software version V7.0		
▶ Encoder evaluation: <a href="#">Provision of the encoder signal of input X8</a>		
<b>Display range</b> (min. value   unit   max. value)		
-214748364.7	rpm	214748364.7
<input checked="" type="checkbox"/> Read access <input type="checkbox"/> Write access <input type="checkbox"/> CINH <input type="checkbox"/> PLC STOP <input type="checkbox"/> No transfer		Scaling factor: 10



## C02765

Parameter   Name: <b>C02765   Enc_bError</b>		Data type: UNSIGNED_32 Index: 21810 <sub>d</sub> = 5532 <sub>h</sub>
From software version V7.0		▶ Encoder evaluation: <a href="#">Provision of the encoder signal of input X8</a>
<b>Selection list (read only)</b>		
0	FALSE	
1	TRUE	
<input checked="" type="checkbox"/> Read access <input type="checkbox"/> Write access <input type="checkbox"/> CINH <input type="checkbox"/> PLC STOP <input type="checkbox"/> No transfer		Scaling factor: 1

## C02770

Parameter   Name: <b>C02770   Operating mode</b>		Data type: UNSIGNED_32 Index: 21805 <sub>d</sub> = 552D <sub>h</sub>
From software version V7.0		▶ Basic function " <a href="#">Manual jog open loop</a> "
<b>Selection list (Lenze setting printed in bold)</b>		
0	<b>Deactivate</b>	
1	<b>Activation</b>	
<b>Subcodes</b>	<b>Lenze setting</b>	<b>Info</b>
C02770/1	0: Deactivate	EnableManualMode
C02770/2	0: Deactivate	JogPositive
C02770/3	0: Deactivate	JogNegative
C02770/4	0: Deactivate	SelectTab1
C02770/5	0: Deactivate	SelectTab2
<input checked="" type="checkbox"/> Read access <input checked="" type="checkbox"/> Write access <input type="checkbox"/> CINH <input type="checkbox"/> PLC STOP <input type="checkbox"/> No transfer		Scaling factor: 1

## C02771

Parameter   Name: <b>C02771   Frequency</b>		Data type: INTEGER_32 Index: 21804 <sub>d</sub> = 552C <sub>h</sub>
From software version V7.0		▶ Basic function " <a href="#">Manual jog open loop</a> "
<b>Setting range (min. value   unit   max. value)</b>		
0.0	Hz	1000.0
<b>Subcodes</b>	<b>Lenze setting</b>	<b>Info</b>
C02771/1	1.0 Hz	Frequency 1
C02771/2	1.0 Hz	Frequency 2
C02771/3	1.0 Hz	Frequency 3
C02771/4	1.0 Hz	Frequency 4
<input checked="" type="checkbox"/> Read access <input checked="" type="checkbox"/> Write access <input type="checkbox"/> CINH <input type="checkbox"/> PLC STOP <input type="checkbox"/> No transfer		Scaling factor: 10

## C02772

Parameter   Name: <b>C02772   Starting angle</b>			Data type: INTEGER_32 Index: 21803 <sub>d</sub> = 552B <sub>h</sub>
From software version V7.0			▶ Basic function " <a href="#">Manual jog open loop</a> "
Setting range (min. value   unit   max. value)			
-180.0	°	180.0	
Subcodes	Lenze setting	Info	
C02772/1	0.0 °	Startangle 1	
C02772/2	0.0 °	Startangle 2	
C02772/3	0.0 °	Startangle 3	
C02772/4	0.0 °	Startangle 4	
<input checked="" type="checkbox"/> Read access <input checked="" type="checkbox"/> Write access <input type="checkbox"/> CINH <input type="checkbox"/> PLC STOP <input type="checkbox"/> No transfer			Scaling factor: 10

## C02773

Parameter   Name: <b>C02773   Current</b>			Data type: INTEGER_32 Index: 21802 <sub>d</sub> = 552A <sub>h</sub>
From software version V7.0			▶ Basic function " <a href="#">Manual jog open loop</a> "
100 % $\frac{1}{2}$   <sub>max_device</sub> ( <a href="#">C00022</a> )			
Setting range (min. value   unit   max. value)			
0.00	%	100.00	
Subcodes	Lenze setting	Info	
C02773/1	10.00 %	Current 1	
C02773/2	10.00 %	Current 2	
C02773/3	10.00 %	Current 3	
C02773/4	10.00 %	Current 4	
<input checked="" type="checkbox"/> Read access <input checked="" type="checkbox"/> Write access <input type="checkbox"/> CINH <input type="checkbox"/> PLC STOP <input type="checkbox"/> No transfer			Scaling factor: 100

## C02774

Parameter   Name: <b>C02774   Acceleration time</b>			Data type: INTEGER_32 Index: 21801 <sub>d</sub> = 5529 <sub>h</sub>
From software version V7.0			▶ Basic function " <a href="#">Manual jog open loop</a> "
Setting range (min. value   unit   max. value)			
0.001	s	2147483.647	
Subcodes	Lenze setting	Info	
C02774/1	1.000 s	Acceleration time 1	
C02774/2	1.000 s	Acceleration time 2	
C02774/3	1.000 s	Acceleration time 3	
C02774/4	1.000 s	Acceleration time 4	
<input checked="" type="checkbox"/> Read access <input checked="" type="checkbox"/> Write access <input type="checkbox"/> CINH <input type="checkbox"/> PLC STOP <input type="checkbox"/> No transfer			Scaling factor: 1000

## C02775

Parameter   Name: <b>C02775   Deceleration time</b>		Data type: INTEGER_32 Index: 21800 <sub>d</sub> = 5528 <sub>h</sub>
From software version V7.0		
		▶ Basic function " <a href="#">Manual jog open loop</a> "
<b>Setting range (min. value   unit   max. value)</b>		
0.001	s	2147483.647
<b>Subcodes</b>	<b>Lenze setting</b>	<b>Info</b>
C02775/1	1.000 s	Deceleration time 1
C02775/2	1.000 s	Deceleration time 2
C02775/3	1.000 s	Deceleration time 3
C02775/4	1.000 s	Deceleration time 4
<input checked="" type="checkbox"/> Read access <input checked="" type="checkbox"/> Write access <input type="checkbox"/> CINH <input type="checkbox"/> PLC STOP <input type="checkbox"/> No transfer		Scaling factor: 1000

## C02776

Parameter   Name: <b>C02776   Time</b>		Data type: INTEGER_32 Index: 21799 <sub>d</sub> = 5527 <sub>h</sub>
From software version V7.0		
		▶ Basic function " <a href="#">Manual jog open loop</a> "
<b>Setting range (min. value   unit   max. value)</b>		
0.001	s	2147483.647
<b>Subcodes</b>	<b>Lenze setting</b>	<b>Info</b>
C02776/1	1.000 s	Max. activation time 1
C02776/2	1.000 s	Max. activation time 2
C02776/3	1.000 s	Max. activation time 3
C02776/4	1.000 s	Max. activation time 4
<input checked="" type="checkbox"/> Read access <input checked="" type="checkbox"/> Write access <input type="checkbox"/> CINH <input type="checkbox"/> PLC STOP <input type="checkbox"/> No transfer		Scaling factor: 1000

## C02779

Parameter   Name: <b>C02779   MOL_SetpointCurrent</b>		Data type: UNSIGNED_32 Index: 21796 <sub>d</sub> = 5524 <sub>h</sub>
From software version V7.0		
Maximum current of the selected profile parameter set.		
		▶ Basic function " <a href="#">Manual jog open loop</a> "
<b>Display range (min. value   unit   max. value)</b>		
0.00	A	42949672.95
<input checked="" type="checkbox"/> Read access <input type="checkbox"/> Write access <input type="checkbox"/> CINH <input type="checkbox"/> PLC STOP <input type="checkbox"/> No transfer		Scaling factor: 100

## C02780

Parameter   Name: <b>C02780   MOL_dnState</b>		Data type: INTEGER_32 Index: 21795 <sub>d</sub> = 5523 <sub>h</sub>
From software version V7.0		
Status of the basic function " <a href="#">Manual jog open loop</a> ".		
<b>Display range (min. value   unit   max. value)</b>		
-2147483648		2147483647
<input checked="" type="checkbox"/> Read access <input type="checkbox"/> Write access <input type="checkbox"/> CINH <input type="checkbox"/> PLC STOP <input type="checkbox"/> No transfer		Scaling factor: 1

## C02781

Parameter   Name: <b>C02781   ManualJogOpenLoop: Dig. signals</b>		Data type: UNSIGNED_32 Index: 21794 <sub>d</sub> = 5522 <sub>h</sub>
From software version V7.0		
Display of the digital signals of the basic function " <a href="#">Manual jog open loop</a> ".		
Selection list (read only)		
0	FALSE	
1	TRUE	
Subcodes	Info	
C02781/1	MOL_bEnable	
C02781/2	MOL_bJogPositive	
C02781/3	MOL_bJogNegative	
C02781/4	MOL_bSelectTab1	
C02781/5	MOL_bSelectTab2	
C02781/6	MOL_bEnabled	
C02781/7	MOL_bActive	
C02781/8	MOL_bDone	
<input checked="" type="checkbox"/> Read access <input type="checkbox"/> Write access <input type="checkbox"/> CINH <input type="checkbox"/> PLC STOP <input type="checkbox"/> No transfer		Scaling factor: 1

## C02785

Parameter   Name: <b>C02785   PPI activation</b>		Data type: UNSIGNED_32 Index: 21790 <sub>d</sub> = 551E <sub>h</sub>
From software version V7.0		
▶ Basic function " <a href="#">pole position identification</a> "		
Selection list (Lenze setting printed in bold)		
0	<b>PPI disabled</b>	
1	PPI in progress	
<input checked="" type="checkbox"/> Read access <input checked="" type="checkbox"/> Write access <input type="checkbox"/> CINH <input type="checkbox"/> PLC STOP <input type="checkbox"/> No transfer		Scaling factor: 1

## C02786

Parameter   Name: <b>C02786   PPI mode</b>		Data type: UNSIGNED_32 Index: 21789 <sub>d</sub> = 551D <sub>h</sub>
From software version V7.0		
▶ Basic function " <a href="#">pole position identification</a> "		
Selection list (Lenze setting printed in bold)		
0	<b>360°</b>	
1	<20°	
<input checked="" type="checkbox"/> Read access <input checked="" type="checkbox"/> Write access <input type="checkbox"/> CINH <input type="checkbox"/> PLC STOP <input type="checkbox"/> No transfer		Scaling factor: 1

## C02787

Parameter   Name: <b>C02787   PPI_dnState</b>		Data type: INTEGER_32 Index: 21788 <sub>d</sub> = 551C <sub>h</sub>
From software version V7.0		
Status of the basic function " <a href="#">pole position identification</a> ".		
Display range (min. value   unit   max. value)		
-2147483648		2147483647
<input checked="" type="checkbox"/> Read access <input type="checkbox"/> Write access <input type="checkbox"/> CINH <input type="checkbox"/> PLC STOP <input type="checkbox"/> No transfer		Scaling factor: 1

## C02788

Parameter   Name: <b>C02788   PolePosition setpoint</b>		Data type: INTEGER_32 Index: 21787 <sub>d</sub> = 551B <sub>h</sub>
From software version V7.0		
▶ Basic function " <a href="#">pole position identification</a> "		
<b>Display range (min. value   unit   max. value)</b>		
-214748364.8	°	214748364.7
<input checked="" type="checkbox"/> Read access <input type="checkbox"/> Write access <input type="checkbox"/> CINH <input type="checkbox"/> PLC STOP <input type="checkbox"/> No transfer		Scaling factor: 10

## C02789

Parameter   Name: <b>C02789   PolePositionIdentification: Dig. signals</b>		Data type: UNSIGNED_32 Index: 21786 <sub>d</sub> = 551A <sub>h</sub>
From software version V7.0		
Display of the digital signals of the basic function " <a href="#">pole position identification</a> ".		
<b>Selection list (read only)</b>		
0	FALSE	
1	TRUE	
<b>Subcodes</b>		<b>Info</b>
C02789/1	PPI_bEnable	
C02789/2	PPI_bStart	
C02789/3	PPI_bLoadPolePosition	
C02789/4	PPI_bResetPolePosition	
C02789/5	PPI_bEnabled	
C02789/6	PPI_bActive	
C02789/7	PPI_bDone	
C02789/8	PPI_bError	
C02789/9	PPI_bPolePositionAvailable	
<input checked="" type="checkbox"/> Read access <input type="checkbox"/> Write access <input type="checkbox"/> CINH <input type="checkbox"/> PLC STOP <input type="checkbox"/> No transfer		Scaling factor: 1

## C02800

Parameter   Name: <b>C02800   Analog input x: Input signal</b>		Data type: INTEGER_16 Index: 21775 <sub>d</sub> = 550F <sub>h</sub>
Scaling: -16384 ≙ -100 %, +16383 ≙ +100 %		
<b>Display range (min. value   unit   max. value)</b>		
-16384		16383
<b>Subcodes</b>		<b>Info</b>
C02800/1	Input signal - analog input 1	
C02800/2	Analog input 2: Input signal	
<input checked="" type="checkbox"/> Read access <input type="checkbox"/> Write access <input type="checkbox"/> CINH <input type="checkbox"/> PLC STOP <input type="checkbox"/> No transfer		Scaling factor: 1

## C02801

Parameter   Name: <b>C02801   Analog output x: Output signal</b>		Data type: INTEGER_16 Index: 21774 <sub>d</sub> = 550E <sub>h</sub>
Scaling: -16384 ≙ -100 %, +16383 ≙ +100 %		
<b>Display range (min. value   unit   max. value)</b>		
-16384		16383
<b>Subcodes</b>		<b>Info</b>
C02801/1		Output signal - analog output 1
C02801/2		Analog output 2: Output signal
<input checked="" type="checkbox"/> Read access <input type="checkbox"/> Write access <input type="checkbox"/> CINH <input type="checkbox"/> PLC STOP <input type="checkbox"/> No transfer		Scaling factor: 1

C02802

Parameter   Name: <b>C02802   Status word: Digital outputs</b>		Data type: BITFIELD_32 Index: 21773 <sub>d</sub> = 550D <sub>h</sub>
Display of the hexadecimal value of the digital outputs • Important: All digital levels are indicated without considering the level logic. Internal signals are displayed as well.		
<b>Display area</b>		
0x00000000		0xFFFFFFFF
<b>Value is bit-coded:</b>		
Bit 0	Reserved	
Bit 1	Reserved	
Bit 2	Reserved	
Bit 3	Reserved	
Bit 4	Reserved	
Bit 5	Reserved	
Bit 6	Reserved	
Bit 7	Reserved	
Bit 8	Reserved	
Bit 9	Reserved	
Bit 10	Reserved	
Bit 11	Reserved	
Bit 12	Dig. output. 1: Terminal state	
Bit 13	Dig. output. 2: Terminal state	
Bit 14	Dig. output. 3: Terminal state	
Bit 15	Dig. output. 4: Terminal state	
Bit 16	Reserved	
Bit 17	Reserved	
Bit 18	Reserved	
Bit 19	Reserved	
Bit 20	Reserved	
Bit 21	Reserved	
Bit 22	Reserved	
Bit 23	Reserved	
Bit 24	Reserved	
Bit 25	Reserved	
Bit 26	Reserved	
Bit 27	Reserved	
Bit 28	Reserved	
Bit 29	Reserved	
Bit 30	Reserved	
Bit 31	Reserved	
<input checked="" type="checkbox"/> Read access <input type="checkbox"/> Write access <input type="checkbox"/> CINH <input type="checkbox"/> PLC STOP <input type="checkbox"/> No transfer		Scaling factor: 1

C02803

Parameter   Name: <b>C02803   Status word: Digital inputs</b>		Data type: BITFIELD_32 Index: 21772 <sub>d</sub> = 550C <sub>n</sub>
Display of the hexadecimal value of the digital inputs • Important: All digital levels are indicated without considering the level logic. Internal signals are displayed as well.		
<b>Display area</b>		
0x00000000		0xFFFFFFFF
<b>Value is bit-coded:</b>		
Bit 0	Dig. input. 1: Terminal state	
Bit 1	Dig. input. 2: Terminal state	
Bit 2	Dig. input. 3: Terminal state	
Bit 3	Dig. input. 4: Terminal state	
Bit 4	Dig. input. 5: Terminal state	
Bit 5	Dig. input. 6: Terminal state	
Bit 6	Dig. input. 7: Terminal state	
Bit 7	Dig. input. 8: Terminal state	
Bit 8	Reserved	
Bit 9	Reserved	
Bit 10	Reserved	
Bit 11	Reserved	
Bit 12	Reserved	
Bit 13	Reserved	
Bit 14	Reserved	
Bit 15	Reserved	
Bit 16	Reserved	
Bit 17	Reserved	
Bit 18	Reserved	
Bit 19	Reserved	
Bit 20	Reserved	
Bit 21	Reserved	
Bit 22	Reserved	
Bit 23	Reserved	
Bit 24	Reserved	
Bit 25	Reserved	
Bit 26	Reserved	
Bit 27	Reserved	
Bit 28	Reserved	
Bit 29	Reserved	
Bit 30	Reserved	
Bit 31	Reserved	
<input checked="" type="checkbox"/> Read access <input type="checkbox"/> Write access <input type="checkbox"/> CINH <input type="checkbox"/> PLC STOP <input type="checkbox"/> No transfer		Scaling factor: 1



## C02810

Parameter   Name:		Data type: UNSIGNED_32 Index: 21765 <sub>d</sub> = 5505 <sub>h</sub>	
<b>C02810   Touch probe x: Delay time</b>			
The delay time set will be considered when the position is determined at the time of touch probe and will be used to compensate for dead times, if necessary.			
• Please observe the setting of the input filter for the digital inputs ( <a href="#">C02830</a> ).			
Setting range (min. value   unit   max. value)			
0	μs	7000	
Subcodes	Lenze setting	Info	
C02810/1	0 μs	TP1 (DI1): Delay time	
C02810/2	0 μs	TP2 (DI2): Delay time	
C02810/3	0 μs	TP3 (DI3): Delay time	
C02810/4	0 μs	TP4 (DI4): Delay time	
C02810/5	0 μs	TP5 (DI5): Delay time	
C02810/6	0 μs	TP6 (DI6): Delay time	
C02810/7	0 μs	TP7 (DI7): Delay time	
C02810/8	0 μs	TP8 (DI8): Delay time	
C02810/9	0 μs	TPM (motor encoder): Delay time	
C02810/10	0 μs	TPL (pos. encoder): Delay time	
<input checked="" type="checkbox"/> Read access <input checked="" type="checkbox"/> Write access <input type="checkbox"/> CINH <input type="checkbox"/> PLC STOP <input type="checkbox"/> No transfer			Scaling factor: 1

C02830

Parameter   Name: <b>C02830   Digital inputs: Delay time</b>		Data type: UNSIGNED_8 Index: 21745 <sub>d</sub> = 54F1 <sub>h</sub>
Input filter for digital inputs <ul style="list-style-type: none"> <li>Can be used to filter out "spikes" at the digital inputs, if necessary.</li> <li>Each digital input is assigned to a subcode.</li> <li>Since the filter is a "counting" filter, the indicated times are only approximate values.</li> </ul>		
Selection list (Lenze setting printed in bold)	Info	
0	2 μs	Filter time
1	4 μs	
2	8 μs	
3	16 μs	
4	32 μs	
5	64 μs	
6	128 μs	
7	256 μs	
8	512 μs	
9	1024 μs	
10	2048 μs	
11	4096 μs	
12	8192 μs	
13	16384 μs	
14	32768 μs	
Subcodes	Lenze setting	Info
C02830/1	0: 2 μs	Setting for digital input 1 ... 8
C02830/...		
C02830/8		
<input checked="" type="checkbox"/> Read access <input checked="" type="checkbox"/> Write access <input type="checkbox"/> CINH <input type="checkbox"/> PLC STOP <input type="checkbox"/> No transfer                   Scaling factor: 1		

C02850

Parameter   Name: <b>C02850   Service code</b>	Data type: UNSIGNED_32 Index: 21724 <sub>d</sub> = 54DD <sub>h</sub>
<b>This code is for device-internal use only and must not be written to by the user!</b>	

C02851

Parameter   Name: <b>C02851   Service code</b>	Data type: UNSIGNED_32 Index: 21724 <sub>d</sub> = 54DC <sub>h</sub>
<b>This code is for device-internal use only and must not be written to by the user!</b>	

C02852

Parameter   Name: <b>C02852   Service code</b>	Data type: UNSIGNED_16 Index: 21723 <sub>d</sub> = 54DB <sub>h</sub>
<b>This code is for device-internal use only and must not be written to by the user!</b>	

## C02853

Parameter   Name: C02853   Lss sat. characteristic			Data type: UNSIGNED_16 Index: 21722 <sub>d</sub> = 54DA <sub>h</sub>
<b>Setting range (min. value   unit   max. value)</b>			
0	%	400	
Subcodes	Lenze setting	Info	
C02853/1	100 %	Saturation characteristic to correct the leakage inductance and the current controller parameters. <ul style="list-style-type: none"> <li>The saturation characteristic is defined by 17 interpolation points which are distributed linearly on the x axis.</li> <li>Interpolation point 17 represents 100 % of the maximum motor current in the process (<a href="#">C02855</a>).</li> <li>The values to be entered in the subcodes represent the y values of the interpolation points 1 ... 17.</li> </ul> ▶ <a href="#">Correction of the leakage inductance via saturation characteristic</a>	
C02853/2	100 %		
C02853/3	100 %		
C02853/4	100 %		
C02853/5	100 %		
C02853/6	100 %		
C02853/7	100 %		
C02853/8	100 %		
C02853/9	100 %		
C02853/10	100 %		
C02853/11	100 %		
C02853/12	100 %		
C02853/13	100 %		
C02853/14	100 %		
C02853/15	100 %		
C02853/16	100 %		
C02853/17	100 %		
<input checked="" type="checkbox"/> Read access <input checked="" type="checkbox"/> Write access <input checked="" type="checkbox"/> CINH <input type="checkbox"/> PLC STOP <input type="checkbox"/> No transfer             Scaling factor: 1			

## C02854

Parameter   Name: C02854   Service code		Data type: UNSIGNED_32 Index: 21721 <sub>d</sub> = 54D9 <sub>h</sub>
<b>This code is for device-internal use only and must not be written to by the user!</b>		

## C02855

Parameter   Name: C02855   I <sub>max</sub> f. Lss sat. characteristic			Data type: UNSIGNED_32 Index: 21720 <sub>d</sub> = 54D8 <sub>h</sub>
Maximum motor current in the process <ul style="list-style-type: none"> <li>Defines the interpolation point 17 of the saturation characteristic set in <a href="#">C02853</a>.</li> </ul> ▶ <a href="#">Correction of the leakage inductance via saturation characteristic</a>			
<b>Setting range (min. value   unit   max. value)</b>			<b>Lenze setting</b>
0.0	A	6000.0	5.4 A
<input checked="" type="checkbox"/> Read access <input checked="" type="checkbox"/> Write access <input checked="" type="checkbox"/> CINH <input type="checkbox"/> PLC STOP <input type="checkbox"/> No transfer             Scaling factor: 10			

## C02856

Parameter   Name: C02856   Service code		Data type: VISIBLE_STRING Index: 21719 <sub>d</sub> = 54D7 <sub>h</sub>
<b>This code is for device-internal use only and must not be written to by the user!</b>		

## C02857

Parameter   Name: <b>C02857   Service code</b>	Data type: VISIBLE_STRING Index: 21718 <sub>d</sub> = 54D6 <sub>h</sub>
<b>This code is for device-internal use only and must not be written to by the user!</b>	

## C02858

Parameter   Name: <b>C02858   Electronic nameplate status</b>	Data type: UNSIGNED_8 Index: 21717 <sub>d</sub> = 54D5 <sub>h</sub>
<b>This code is for device-internal use only and must not be written to by the user!</b>	

## C02859

Parameter   Name: <b>C02859   Activate Lss sat. char.</b>	Data type: UNSIGNED_8 Index: 21716 <sub>d</sub> = 54D4 <sub>h</sub>
▶ <a href="#">Correction of the leakage inductance via saturation characteristic</a>	
<b>Selection list</b> (Lenze setting printed in bold)	
0	<b>Off</b>
1	On
<input checked="" type="checkbox"/> Read access <input checked="" type="checkbox"/> Write access <input checked="" type="checkbox"/> CINH <input type="checkbox"/> PLC STOP <input type="checkbox"/> No transfer           Scaling factor: 1	

## C02860

Parameter   Name: <b>C02860   Rr adjustment</b>	Data type: UNSIGNED_32 Index: 21715 <sub>d</sub> = 54D3 <sub>h</sub>
<b>Setting range</b> (min. value   unit   max. value)	<b>Lenze setting</b>
50.00      %      200.00	<b>100.00 %</b>
<input checked="" type="checkbox"/> Read access <input checked="" type="checkbox"/> Write access <input type="checkbox"/> CINH <input type="checkbox"/> PLC STOP <input type="checkbox"/> No transfer           Scaling factor: 100	

## C02861

Parameter   Name: <b>C02861   Lh adjustment</b>	Data type: UNSIGNED_32 Index: 21714 <sub>d</sub> = 54D2 <sub>h</sub>
<b>Setting range</b> (min. value   unit   max. value)	<b>Lenze setting</b>
50.00      %      200.00	<b>100.00 %</b>
<input checked="" type="checkbox"/> Read access <input checked="" type="checkbox"/> Write access <input type="checkbox"/> CINH <input type="checkbox"/> PLC STOP <input type="checkbox"/> No transfer           Scaling factor: 100	

## C02862

Parameter   Name: <b>C02862   Resolver: Gain</b>	Data type: UNSIGNED_16 Index: 21713 <sub>d</sub> = 54D1 <sub>h</sub>	
From software version V7.0		
▶ <a href="#">Resolver error compensation</a>		
<b>Setting range</b> (min. value   unit   max. value)		
0	100	
<b>Subcodes</b>	<b>Lenze setting</b>	<b>Info</b>
C02862/1	100	Gain of cosine track
C02862/2	100	Gain of sine track
<input checked="" type="checkbox"/> Read access <input checked="" type="checkbox"/> Write access <input type="checkbox"/> CINH <input type="checkbox"/> PLC STOP <input type="checkbox"/> No transfer           Scaling factor: 1		

## C02863

Parameter   Name: <b>C02863   Resolver: phase correction</b>		Data type: INTEGER_16 Index: 21712 <sub>d</sub> = 54D0 <sub>h</sub>	
From software version V7.0			
▶ <a href="#">Resolver error compensation</a>			
Setting range (min. value   unit   max. value)			Lenze setting
-100		100	<b>0</b>
<input checked="" type="checkbox"/> Read access <input checked="" type="checkbox"/> Write access <input type="checkbox"/> CINH <input type="checkbox"/> PLC STOP <input type="checkbox"/> No transfer			Scaling factor: 1

## C02864

Parameter   Name: <b>C02864   Service code</b>		Data type: INTEGER_32 Index: 21711 <sub>d</sub> = 54CF <sub>h</sub>	
<b>This code is for device-internal use only and must not be written to by the user!</b>			

## C02865

Parameter   Name: <b>C02865   Adaptation of Ur</b>		Data type: UNSIGNED_32 Index: 21710 <sub>d</sub> = 54CE <sub>h</sub>	
From software version V8.0			
Setting range (min. value   unit   max. value)			Lenze setting
50.00	%	200.00	<b>100.00 %</b>
<input checked="" type="checkbox"/> Read access <input checked="" type="checkbox"/> Write access <input type="checkbox"/> CINH <input type="checkbox"/> PLC STOP <input type="checkbox"/> No transfer			Scaling factor: 100

## C02866

Parameter   Name: <b>C02866   Curr. control par. of C75 C76</b>		Data type: UNSIGNED_8 Index: 21709 <sub>d</sub> = 54CD <sub>h</sub>	
<b>This code is for device-internal use only and must not be written to by the user!</b>			

## C02867

Parameter   Name: <b>C02867   Motor phase failure volt. threshold</b>		Data type: INTEGER_32 Index: 21708 <sub>d</sub> = 54CC <sub>h</sub>	
From software version V10.0			
Setting range (min. value   unit   max. value)			Lenze setting
0.0	V	1000.0	<b>10.0 V</b>
<input checked="" type="checkbox"/> Read access <input checked="" type="checkbox"/> Write access <input type="checkbox"/> CINH <input type="checkbox"/> PLC STOP <input type="checkbox"/> No transfer			Scaling factor: 10

## C02868

Parameter   Name: <b>C02868   Service code</b>		Data type: UNSIGNED_32 Index: 21707 <sub>d</sub> = 54CB <sub>h</sub>	
<b>This code is for device-internal use only and must not be written to by the user!</b>			

## C02869

Parameter   Name: <b>C02869   Service code</b>		Data type: UNSIGNED_32 Index: 21706 <sub>d</sub> = 54CA <sub>h</sub>	
<b>This code is for device-internal use only and must not be written to by the user!</b>			

## C02870

Parameter   Name: <b>C02870   Service code</b>	Data type: UNSIGNED_32 Index: 21705 <sub>d</sub> = 54C9 <sub>h</sub>
<b>This code is for device-internal use only and must not be written to by the user!</b>	

## C02871

Parameter   Name: <b>C02871   Voltage reserve</b>	Data type: UNSIGNED_32 Index: 21704 <sub>d</sub> = 54C8 <sub>h</sub>
From software version V12.0 Voltage reserve at the transition point to field weakening <ul style="list-style-type: none"> <li>• Only relevant for servo control for asynchronous motor (selection "2" in <a href="#">C00006</a>).</li> </ul>	
<b>Setting range</b> (min. value   unit   max. value)	<b>Lenze setting</b>
1   %   20	5 %
<input checked="" type="checkbox"/> Read access <input checked="" type="checkbox"/> Write access <input type="checkbox"/> CINH <input type="checkbox"/> PLC STOP <input type="checkbox"/> No transfer   Scaling factor: 1	

## C02872

Parameter   Name: <b>C02872   PLI 360° result in C58</b>	Data type: UNSIGNED_32 Index: 21703 <sub>d</sub> = 54C7 <sub>h</sub>
From software version V15.0 onwards <p style="text-align: right;">▶ Result in <a href="#">C0058</a></p>	
<b>Selection list</b> (Lenze setting printed in bold)	<b>Info</b>
0 <b>OFF</b>	
1 <b>ON</b>	In the case of PLI 360°, the absolute position determined is not saved in the encoder, but is transferred to code <a href="#">C0058:2</a> instead. This is the response compatible with i700 / i900.
<input checked="" type="checkbox"/> Read access <input checked="" type="checkbox"/> Write access <input type="checkbox"/> CINH <input type="checkbox"/> PLC STOP <input type="checkbox"/> No transfer   Scaling factor: 1	

## C02900

Parameter   Name: <b>C02900   User Password</b>	Data type: VISIBLE_STRING Index: 21675 <sub>d</sub> = 54AB <sub>h</sub>
From software version V3.0 If the cam data are provided with a user password, the defined user password must be entered once to execute the following actions: <ul style="list-style-type: none"> <li>• Changing the cam data via parameter setting</li> <li>• Loading/saving the cam data</li> </ul> <b>Validity</b> The user password entered is maintained until the next download, mains switching, or until reset by the user (logout). <ul style="list-style-type: none"> <li>• You can "logout" deliberately by entering an invalid password.</li> </ul> <p style="text-align: right;">▶ Basic function "<a href="#">Cam data management</a>"</p>	
<input checked="" type="checkbox"/> Read access <input checked="" type="checkbox"/> Write access <input type="checkbox"/> CINH <input type="checkbox"/> PLC STOP <input checked="" type="checkbox"/> No transfer   Character length: 22	

## C02901

Parameter   Name: <b>C02901   CamMemory</b>		Data type: UNSIGNED_32 Index: 21674 <sub>d</sub> = 54AA <sub>h</sub>
From software version V5.0		
▶ Basic function "Cam data management": <a href="#">Memory mapping</a>		
<b>Display range (min. value   unit   max. value)</b>		
0		4294967295
<b>Subcodes</b>		<b>Info</b>
C02901/1		Size of the memory for quick download to RAM
C02901/2		Size of the memory for "Online change"
C02901/3		Size of the memory from which the cam data are processed.
<input checked="" type="checkbox"/> Read access <input type="checkbox"/> Write access <input type="checkbox"/> CINH <input type="checkbox"/> PLC STOP <input type="checkbox"/> No transfer		Scaling factor: 1

## C02902

Parameter   Name: <b>C02902   Timestamp</b>		Data type: UNSIGNED_32 Index: 21673 <sub>d</sub> = 54A9 <sub>h</sub>
From software version V3.0		
▶ Basic function " <a href="#">Cam data management</a> "		
<b>Display range (min. value   unit   max. value)</b>		
0		4294967295
<b>Subcodes</b>		<b>Info</b>
C02902/1		Time stamp of the cam data in the controller
C02902/2		Time stamp of the cam data which are currently being processed in the controller.
C02902/3		Time stamp of the cam data in the controller which have already been converted into the internal format.
C02902/4		Time stamp of the cam data in the memory module
<input checked="" type="checkbox"/> Read access <input type="checkbox"/> Write access <input type="checkbox"/> CINH <input type="checkbox"/> PLC STOP <input type="checkbox"/> No transfer		Scaling factor: 1

## C02903

Parameter   Name: <b>C02903   GUID</b>		Data type: OCTET_STRING Index: 21672 <sub>d</sub> = 54A8 <sub>h</sub>
From software version V3.0		
▶ Basic function " <a href="#">Cam data management</a> "		
<b>Display range (min. value   unit   max. value)</b>		
<b>Subcodes</b>		<b>Info</b>
C02903/1		GUID of the cam data in the controller
C02903/2		GUID of the cam data which are currently being processed in the controller.
C02903/3		GUID of the cam data in the controller which have already been converted into the internal format.
C02903/4		GUID of the cam data in the memory module
<input checked="" type="checkbox"/> Read access <input type="checkbox"/> Write access <input type="checkbox"/> CINH <input type="checkbox"/> PLC STOP <input type="checkbox"/> No transfer		Scaling factor: 1

## C02905

Parameter   Name: <b>C02905   Online Change Mode</b>		Data type: UNSIGNED_32 Index: 21670 <sub>d</sub> = 54A6 <sub>h</sub>
From software version V3.0		
▶ Basic function "Cam data management": <a href="#">Online change mode</a>		
<b>Selection list</b> (Lenze setting printed in bold)		
10	Manual activation	
15	Automatic activation	
<b>16</b>	<b>Automatic activation with controller inhibit</b>	
<input checked="" type="checkbox"/> Read access <input checked="" type="checkbox"/> Write access <input type="checkbox"/> CINH <input type="checkbox"/> PLC STOP <input type="checkbox"/> No transfer		Scaling factor: 1

## C02906

Parameter   Name: <b>C02906   Online Change State</b>		Data type: UNSIGNED_32 Index: 21669 <sub>d</sub> = 54A5 <sub>h</sub>
From software version V3.0		
▶ Basic function "Cam data management": <a href="#">Online change mode</a>		
<b>Selection list</b> (read only)		
0	Ready	
5	Initialisation	
7	Saving is active	
8	Loading is active	
11	Waiting for controlled acceptance	
<input checked="" type="checkbox"/> Read access <input type="checkbox"/> Write access <input type="checkbox"/> CINH <input type="checkbox"/> PLC STOP <input type="checkbox"/> No transfer		Scaling factor: 1

## C02908

Parameter   Name: <b>C02908   Product Count</b>		Data type: UNSIGNED_32 Index: 21667 <sub>d</sub> = 54A3 <sub>h</sub>
From software version V3.0		
Display of the highest product number +1 of the cam data currently being processed		
▶ Basic function " <a href="#">Cam data management</a> "		
<b>Display range</b> (min. value   unit   max. value)		
0		0
<input checked="" type="checkbox"/> Read access <input type="checkbox"/> Write access <input type="checkbox"/> CINH <input type="checkbox"/> PLC STOP <input type="checkbox"/> No transfer		Scaling factor: 1

## C02909

Parameter   Name: <b>C02909   Active Product</b>		Data type: UNSIGNED_32 Index: 21666 <sub>d</sub> = 54A2 <sub>h</sub>
From software version V3.0		
Display of the product number of the active product of the cam data currently being processed		
▶ Basic function " <a href="#">Cam data management</a> "		
<b>Display range</b> (min. value   unit   max. value)		
0		0
<input checked="" type="checkbox"/> Read access <input type="checkbox"/> Write access <input type="checkbox"/> CINH <input type="checkbox"/> PLC STOP <input type="checkbox"/> No transfer		Scaling factor: 1



## C02910

Parameter   Name: <b>C02910   Product Name</b>		Data type: VISIBLE_STRING Index: 21665 <sub>d</sub> = 54A1 <sub>h</sub>
From software version V3.0		▶ Basic function " <a href="#">Cam data management</a> "
<input checked="" type="checkbox"/> Read access	<input type="checkbox"/> Write access	<input type="checkbox"/> CINH <input type="checkbox"/> PLC STOP <input type="checkbox"/> No transfer    Scaling factor: 1    Character length: 16

## C02911

Parameter   Name: <b>C02911   Product Choice</b>		Data type: UNSIGNED_32 Index: 21664 <sub>d</sub> = 54A0 <sub>h</sub>
From software version V3.0		▶ <a href="#">Changing cam data via parameterisation</a>
<b>Setting range (min. value   unit   max. value)</b>		<b>Lenze setting</b>
0		255    0
<input checked="" type="checkbox"/> Read access	<input checked="" type="checkbox"/> Write access	<input type="checkbox"/> CINH <input type="checkbox"/> PLC STOP <input checked="" type="checkbox"/> No transfer    Scaling factor: 1

## C02912

Parameter   Name: <b>C02912   Product Count</b>		Data type: UNSIGNED_32 Index: 21663 <sub>d</sub> = 549F <sub>h</sub>
From software version V3.0		▶ <a href="#">Changing cam data via parameterisation</a>
<b>Display range (min. value   unit   max. value)</b>		
0		65536
<input checked="" type="checkbox"/> Read access	<input type="checkbox"/> Write access	<input type="checkbox"/> CINH <input type="checkbox"/> PLC STOP <input type="checkbox"/> No transfer    Scaling factor: 1

## C02919

Parameter   Name: <b>C02919   Number Of Cam Tracks</b>		Data type: UNSIGNED_32 Index: 21656 <sub>d</sub> = 5498 <sub>h</sub>
From software version V3.0		▶ <a href="#">Changing cam data via parameterisation</a>
<b>Display range (min. value   unit   max. value)</b>		
0		65535
<input checked="" type="checkbox"/> Read access	<input type="checkbox"/> Write access	<input type="checkbox"/> CINH <input type="checkbox"/> PLC STOP <input type="checkbox"/> No transfer    Scaling factor: 1

## C02920

Parameter   Name: <b>C02920   Cam Track Choice</b>		Data type: UNSIGNED_32 Index: 21655 <sub>d</sub> = 5497 <sub>h</sub>
From software version V3.0		▶ <a href="#">Changing cam data via parameterisation</a>
<b>Setting range (min. value   unit   max. value)</b>		<b>Lenze setting</b>
0		65535    0
<input checked="" type="checkbox"/> Read access	<input checked="" type="checkbox"/> Write access	<input type="checkbox"/> CINH <input type="checkbox"/> PLC STOP <input checked="" type="checkbox"/> No transfer    Scaling factor: 1

## C02921

Parameter   Name: <b>C02921   Cam Track Type</b>		Data type: UNSIGNED_32 Index: 21654 <sub>d</sub> = 5496 <sub>h</sub>
From software version V3.0		<a href="#">▶ Changing cam data via parameterisation</a>
<b>Selection list (read only)</b>		
1	Linear	
5	Spline	
11	LinearPC	
15	SplinePC	
<input checked="" type="checkbox"/> Read access <input type="checkbox"/> Write access <input type="checkbox"/> CINH <input type="checkbox"/> PLC STOP <input type="checkbox"/> No transfer		Scaling factor: 1

## C02922

Parameter   Name: <b>C02922   Number Of Cam Data Points</b>		Data type: UNSIGNED_32 Index: 21653 <sub>d</sub> = 5495 <sub>h</sub>
From software version V3.0		<a href="#">▶ Changing cam data via parameterisation</a>
<b>Display range (min. value   unit   max. value)</b>		
0		65535
<input checked="" type="checkbox"/> Read access <input type="checkbox"/> Write access <input type="checkbox"/> CINH <input type="checkbox"/> PLC STOP <input type="checkbox"/> No transfer		Scaling factor: 1

## C02923

Parameter   Name: <b>C02923   Cam Data Point Choice</b>		Data type: UNSIGNED_32 Index: 21652 <sub>d</sub> = 5494 <sub>h</sub>
From software version V3.0		<a href="#">▶ Changing cam data via parameterisation</a>
<b>Setting range (min. value   unit   max. value)</b>		<b>Lenze setting</b>
0		65535
<input checked="" type="checkbox"/> Read access <input checked="" type="checkbox"/> Write access <input type="checkbox"/> CINH <input type="checkbox"/> PLC STOP <input checked="" type="checkbox"/> No transfer		Scaling factor: 1

## C02924

Parameter   Name: <b>C02924   Change Cam Data Point X</b>		Data type: INTEGER_32 Index: 21651 <sub>d</sub> = 5493 <sub>h</sub>
From software version V3.0		<a href="#">▶ Changing cam data via parameterisation</a>
<b>Setting range (min. value   unit   max. value)</b>		<b>Lenze setting</b>
-214748.3647	Unit	214748.3647
<input checked="" type="checkbox"/> Read access <input checked="" type="checkbox"/> Write access <input type="checkbox"/> CINH <input type="checkbox"/> PLC STOP <input checked="" type="checkbox"/> No transfer		Scaling factor: 10000

## C02925

Parameter   Name: <b>C02925   Change Cam Data Point Y</b>		Data type: INTEGER_32 Index: 21650 <sub>d</sub> = 5492 <sub>h</sub>
From software version V3.0		<a href="#">▶ Changing cam data via parameterisation</a>
<b>Setting range (min. value   unit   max. value)</b>		<b>Lenze setting</b>
-214748.3647	Unit	214748.3647
<input checked="" type="checkbox"/> Read access <input checked="" type="checkbox"/> Write access <input type="checkbox"/> CINH <input type="checkbox"/> PLC STOP <input checked="" type="checkbox"/> No transfer		Scaling factor: 10000

## C02926

Parameter   Name: <b>C02926   Change Cam Data Point M</b>			Data type: INTEGER_32 Index: 21649 <sub>d</sub> = 5491 <sub>h</sub>
From software version V3.0			<a href="#">▶ Changing cam data via parameterisation</a>
<b>Setting range (min. value   unit   max. value)</b>		<b>Lenze setting</b>	
-200.00	%	200.00	<b>0.00 %</b>
<input checked="" type="checkbox"/> Read access <input checked="" type="checkbox"/> Write access <input type="checkbox"/> CINH <input type="checkbox"/> PLC STOP <input checked="" type="checkbox"/> No transfer			Scaling factor: 100

## C02927

Parameter   Name: <b>C02927   Auto Inc Cam Data Points</b>			Data type: UNSIGNED_32 Index: 21648 <sub>d</sub> = 5490 <sub>h</sub>
From software version V3.0			<a href="#">▶ Changing cam data via parameterisation</a>
<b>Selection list (Lenze setting printed in bold)</b>			
<b>0</b>	<b>Deactivate</b>		
1	Activation		
<input checked="" type="checkbox"/> Read access <input checked="" type="checkbox"/> Write access <input type="checkbox"/> CINH <input type="checkbox"/> PLC STOP <input checked="" type="checkbox"/> No transfer			Scaling factor: 1

## C02939

Parameter   Name: <b>C02939   Number Of Cont Tracks</b>			Data type: UNSIGNED_32 Index: 21636 <sub>d</sub> = 5484 <sub>h</sub>
From software version V3.0			<a href="#">▶ Changing cam data via parameterisation</a>
<b>Display range (min. value   unit   max. value)</b>			
0		65535	
<input checked="" type="checkbox"/> Read access <input type="checkbox"/> Write access <input type="checkbox"/> CINH <input type="checkbox"/> PLC STOP <input type="checkbox"/> No transfer			Scaling factor: 1

## C02940

Parameter   Name: <b>C02940   Cont Track Choice</b>			Data type: UNSIGNED_32 Index: 21635 <sub>d</sub> = 5483 <sub>h</sub>
From software version V3.0			<a href="#">▶ Changing cam data via parameterisation</a>
<b>Setting range (min. value   unit   max. value)</b>		<b>Lenze setting</b>	
0		65535	<b>0</b>
<input checked="" type="checkbox"/> Read access <input checked="" type="checkbox"/> Write access <input type="checkbox"/> CINH <input type="checkbox"/> PLC STOP <input checked="" type="checkbox"/> No transfer			Scaling factor: 1

**C02941**

Parameter   Name: <b>C02941   Cont Type</b>		Data type: UNSIGNED_32 Index: 21634 <sub>d</sub> = 5482 <sub>h</sub>
From software version V3.0		
<a href="#">▶ Changing cam data via parameterisation</a>		
<b>Selection list (read only)</b>		
1	Pos. position cam	
2	Neg. position cam	
3	Bidirect. position cam	
11	Pos. time cam	
12	Neg. time cam	
<input checked="" type="checkbox"/> Read access <input type="checkbox"/> Write access <input type="checkbox"/> CINH <input type="checkbox"/> PLC STOP <input type="checkbox"/> No transfer		Scaling factor: 1

**C02942**

Parameter   Name: <b>C02942   Number Of Cont Data Points</b>		Data type: UNSIGNED_32 Index: 21633 <sub>d</sub> = 5481 <sub>h</sub>
From software version V3.0		
<a href="#">▶ Changing cam data via parameterisation</a>		
<b>Display range (min. value   unit   max. value)</b>		
0		65535
<input checked="" type="checkbox"/> Read access <input type="checkbox"/> Write access <input type="checkbox"/> CINH <input type="checkbox"/> PLC STOP <input type="checkbox"/> No transfer		Scaling factor: 1

**C02943**

Parameter   Name: <b>C02943   Cont Data Point Choice</b>		Data type: UNSIGNED_32 Index: 21632 <sub>d</sub> = 5480 <sub>h</sub>
From software version V3.0		
<a href="#">▶ Changing cam data via parameterisation</a>		
<b>Setting range (min. value   unit   max. value)</b>		<b>Lenze setting</b>
0		65535
<input checked="" type="checkbox"/> Read access <input checked="" type="checkbox"/> Write access <input type="checkbox"/> CINH <input type="checkbox"/> PLC STOP <input checked="" type="checkbox"/> No transfer		Scaling factor: 1

**C02944**

Parameter   Name: <b>C02944   Cont Pos X0</b>		Data type: INTEGER_32 Index: 21631 <sub>d</sub> = 547F <sub>h</sub>
From software version V3.0		
<a href="#">▶ Changing cam data via parameterisation</a>		
<b>Setting range (min. value   unit   max. value)</b>		<b>Lenze setting</b>
-214748.3647	Unit	214748.3647
<input checked="" type="checkbox"/> Read access <input checked="" type="checkbox"/> Write access <input type="checkbox"/> CINH <input type="checkbox"/> PLC STOP <input checked="" type="checkbox"/> No transfer		Scaling factor: 10000

# 14 Parameter reference

## 14.2 Parameter list

### C02945

Parameter   Name: <b>C02945   Cont Pos X1</b>			Data type: INTEGER_32 Index: 21630 <sub>d</sub> = 547E <sub>h</sub>	
From software version V3.0				
<a href="#">▶ Changing cam data via parameterisation</a>				
Setting range (min. value   unit   max. value)			Lenze setting	
-214748.3647	Unit	214748.3647	0.0000 Unit	
<input checked="" type="checkbox"/> Read access <input checked="" type="checkbox"/> Write access <input type="checkbox"/> CINH <input type="checkbox"/> PLC STOP <input checked="" type="checkbox"/> No transfer			Scaling factor: 10000	

### C02946

Parameter   Name: <b>C02946   Cont Time</b>			Data type: UNSIGNED_32 Index: 21629 <sub>d</sub> = 547D <sub>h</sub>	
From software version V3.0				
<a href="#">▶ Changing cam data via parameterisation</a>				
Setting range (min. value   unit   max. value)			Lenze setting	
0.0000	ms	214748.3647	0.0000 ms	
<input checked="" type="checkbox"/> Read access <input checked="" type="checkbox"/> Write access <input type="checkbox"/> CINH <input type="checkbox"/> PLC STOP <input checked="" type="checkbox"/> No transfer			Scaling factor: 10000	

### C02959

Parameter   Name: <b>C02959   Number of Pos Tracks</b>			Data type: UNSIGNED_32 Index: 21616 <sub>d</sub> = 5470 <sub>h</sub>	
From software version V3.0				
<a href="#">▶ Changing cam data via parameterisation</a>				
Display range (min. value   unit   max. value)				
0		65535		
<input checked="" type="checkbox"/> Read access <input type="checkbox"/> Write access <input type="checkbox"/> CINH <input type="checkbox"/> PLC STOP <input type="checkbox"/> No transfer			Scaling factor: 1	

### C02960

Parameter   Name: <b>C02960   Pos Track Choice</b>			Data type: UNSIGNED_32 Index: 21615 <sub>d</sub> = 546F <sub>h</sub>	
From software version V3.0				
<a href="#">▶ Changing cam data via parameterisation</a>				
Setting range (min. value   unit   max. value)			Lenze setting	
0		65535	0	
<input checked="" type="checkbox"/> Read access <input checked="" type="checkbox"/> Write access <input type="checkbox"/> CINH <input type="checkbox"/> PLC STOP <input checked="" type="checkbox"/> No transfer			Scaling factor: 1	

### C02962

Parameter   Name: <b>C02962   Number of Pos Data Points</b>			Data type: UNSIGNED_32 Index: 21613 <sub>d</sub> = 546D <sub>h</sub>	
From software version V3.0				
<a href="#">▶ Changing cam data via parameterisation</a>				
Display range (min. value   unit   max. value)				
0		65535		
<input checked="" type="checkbox"/> Read access <input type="checkbox"/> Write access <input type="checkbox"/> CINH <input type="checkbox"/> PLC STOP <input type="checkbox"/> No transfer			Scaling factor: 1	

## C02963

Parameter   Name: <b>C02963   Pos Data Point Choice</b>		Data type: UNSIGNED_32 Index: 21612 <sub>d</sub> = 546C <sub>h</sub>	
From software version V3.0			
<a href="#">▶ Changing cam data via parameterisation</a>			
Setting range (min. value   unit   max. value)		Lenze setting	
0		65535	<b>0</b>
<input checked="" type="checkbox"/> Read access <input checked="" type="checkbox"/> Write access <input type="checkbox"/> CINH <input type="checkbox"/> PLC STOP <input checked="" type="checkbox"/> No transfer		Scaling factor: 1	

## C02964

Parameter   Name: <b>C02964   Change Pos Data Point X</b>		Data type: INTEGER_32 Index: 21611 <sub>d</sub> = 546B <sub>h</sub>	
From software version V3.0			
<a href="#">▶ Changing cam data via parameterisation</a>			
Setting range (min. value   unit   max. value)		Lenze setting	
-214748.3647	Unit	214748.3647	<b>0.0000 Unit</b>
<input checked="" type="checkbox"/> Read access <input checked="" type="checkbox"/> Write access <input type="checkbox"/> CINH <input type="checkbox"/> PLC STOP <input checked="" type="checkbox"/> No transfer		Scaling factor: 10000	

## C02965

Parameter   Name: <b>C02965   Change Pos Data Point Y</b>		Data type: INTEGER_32 Index: 21610 <sub>d</sub> = 546A <sub>h</sub>	
From software version V3.0			
<a href="#">▶ Changing cam data via parameterisation</a>			
Setting range (min. value   unit   max. value)		Lenze setting	
-214748.3647	Unit	214748.3647	<b>0.0000 Unit</b>
<input checked="" type="checkbox"/> Read access <input checked="" type="checkbox"/> Write access <input type="checkbox"/> CINH <input type="checkbox"/> PLC STOP <input checked="" type="checkbox"/> No transfer		Scaling factor: 10000	

## C02996

Parameter   Name: <b>C02996   Service code</b>		Data type: UNSIGNED_32 Index: 21579 <sub>d</sub> = 544B <sub>h</sub>	
<b>This code is for device-internal use only and must not be written to by the user!</b>			

## C02997

Parameter   Name: <b>C02997   Service code</b>		Data type: UNSIGNED_32 Index: 21578 <sub>d</sub> = 544A <sub>h</sub>	
<b>This code is for device-internal use only and must not be written to by the user!</b>			

## C02998

Parameter   Name: <b>C02998   Service code</b>		Data type: UNSIGNED_32 Index: 21577 <sub>d</sub> = 5449 <sub>h</sub>	
<b>This code is for device-internal use only and must not be written to by the user!</b>			

## C02999

Parameter   Name: <b>C02999   Service code</b>		Data type: UNSIGNED_32 Index: 21576 <sub>d</sub> = 5448 <sub>h</sub>	
<b>This code is for device-internal use only and must not be written to by the user!</b>			

# 14 Parameter reference

## 14.3 Table of attributes

---

### 14.3 Table of attributes

The table of attributes contains information required for communication with the inverter via parameters.

## How to read the table of attributes:

Column		Meaning	Entry	
code		Parameter name	Cxxxx	
Name		Parameter short text (display text)	Text	
Type		Parameter type	Selection list	Value from selection list
			Bit coded	Bit coded value
			Linear value	Value with setting range
			String	String
Index	dec	Index under which the parameter is addressed. The subindex for array variables corresponds to the Lenze subcode number.	24575 - Lenze code number	Is only required for access via a bus system.
	hex		5FFF <sub>h</sub> - Lenze code number	
Data	DS	Data structure	E	Single variable (only one parameter element)
			A	Array variable (several parameter elements)
	DA	Number of array elements (subcodes)	Number	
	DT	Data type	BITFIELD_8	1 byte, bit-coded
			BITFIELD_16	2 bytes bit-coded
			BITFIELD_32	4 bytes bit-coded
			INTEGER_8	1 byte, with sign
			INTEGER_16	2 bytes with sign
			INTEGER_32	4 bytes with sign
			UNSIGNED_8	1 byte without sign
UNSIGNED_16			2 bytes without sign	
UNSIGNED_32	4 bytes without sign			
VISIBLE_STRING [xx]	ASCII string (with character length xx)			
Factor	Factor for data transmission via a bus system, depending on the number of decimal positions	Factor	1 = No decimal positions 10 = 1 decimal position 100 = 2 decimal positions 1000 = 3 decimal positions 10000 = 4 decimal positions	
CINH	Writing is only possible if the controller is inhibited	CINH		

code	Name	Parameter type	Index		Data				
			dec	hex	DS	DA	Data type	Factor	CINH
<a href="#">C00002</a>	Device commands	Selection list	24573	5FFD	E	1	UNSIGNED_32	1	
<a href="#">C00003</a>	Device command status	Linear value	24572	5FFC	E	1	UNSIGNED_32	1	
<a href="#">C00004</a>	Service password	Linear value	24571	5FFB	E	1	UNSIGNED_32	1	
<a href="#">C00005</a>	Application selection	Linear value	24570	5FFA	E	1	INTEGER_32	1	
<a href="#">C00006</a>	Select motor control	Selection list	24569	5FF9	E	1	UNSIGNED_32	1	CINH
<a href="#">C00007</a>	Active application	Linear value	24568	5FF8	E	1	INTEGER_32	1	
<a href="#">C00008</a>	Device command progress	Linear value	24567	5FF7	E	1	UNSIGNED_32	1	
<a href="#">C00011</a>	Reference speed motor	Linear value	24564	5FF4	E	1	UNSIGNED_32	1	
<a href="#">C00018</a>	Switching frequency	Selection list	24557	5FED	E	1	UNSIGNED_32	1	
<a href="#">C00019</a>	Threshold - standstill recognition	Linear value	24556	5FEC	E	1	UNSIGNED_32	1	
<a href="#">C00022</a>	Maximum current	Linear value	24553	5FE9	E	1	UNSIGNED_32	100	
<a href="#">C00034</a>	Config. analog input 1	Selection list	24541	5FDD	E	1	UNSIGNED_32	1	
<a href="#">C00050</a>	Speed setpoint [rpm]	Linear value	24525	5FCD	A	2	INTEGER_32	1	
<a href="#">C00051</a>	Actual speed value [min-1]	Linear value	24524	5FCC	E	1	INTEGER_32	1	
<a href="#">C00052</a>	Motor voltage	Linear value	24523	5FCB	E	1	UNSIGNED_32	1	
<a href="#">C00053</a>	DC-bus voltage	Linear value	24522	5FCA	E	1	UNSIGNED_32	1	
<a href="#">C00054</a>	Motor current	Linear value	24521	5FC9	E	1	UNSIGNED_32	100	
<a href="#">C00055</a>	Phase currents	Linear value	24520	5FC8	A	4	INTEGER_32	100	
<a href="#">C00056</a>	Torque setpoint	Linear value	24519	5FC7	E	1	INTEGER_32	100	
<a href="#">C00057</a>	Torque	Linear value	24518	5FC6	A	2	UNSIGNED_32	1000	



code	Name	Parameter type	Index		Data				
			dec	hex	DS	DA	Data type	Factor	CINH
<a href="#">C00058</a>	Pole position	Linear value	24517	5FC5	A	3	INTEGER_32	10	
<a href="#">C00059</a>	Motor - number of pole pairs	Linear value	24516	5FC4	E	1	UNSIGNED_32	1	
<a href="#">C00060</a>	Motor pole angle	Linear value	24515	5FC3	E	1	INTEGER_32	1	
<a href="#">C00061</a>	Heatsink temperature	Linear value	24514	5FC2	E	1	INTEGER_32	1	
<a href="#">C00062</a>	Interior temperature	Linear value	24513	5FC1	E	1	INTEGER_32	1	
<a href="#">C00063</a>	Motor temperature	Linear value	24512	5FC0	E	1	INTEGER_32	1	
<a href="#">C00064</a>	Device utilisation (lxt)	Linear value	24511	5FBF	E	1	UNSIGNED_32	1	
<a href="#">C00065</a>	Ext. 24-V voltage	Linear value	24510	5FBE	E	1	INTEGER_32	10	
<a href="#">C00066</a>	Thermal motor load (l*xt)	Linear value	24509	5FBD	E	1	UNSIGNED_32	1	
<a href="#">C00068</a>	Capacitor temperature	Linear value	24507	5FBB	E	1	INTEGER_32	1	
<a href="#">C00069</a>	CPU temperature	Linear value	24506	5FBA	E	1	INTEGER_32	1	
<a href="#">C00070</a>	Speed controller gain	Linear value	24505	5FB9	E	1	UNSIGNED_32	100000	
<a href="#">C00071</a>	Speed controller reset time	Linear value	24504	5FB8	E	1	UNSIGNED_32	10	
<a href="#">C00072</a>	Speed controller rate time	Linear value	24503	5FB7	E	1	UNSIGNED_32	100	
<a href="#">C00074</a>	Feedfwd. ctrl. - current contr.	Selection list	24501	5FB5	E	1	UNSIGNED_8	1	
<a href="#">C00075</a>	Current controller gain	Linear value	24500	5FB4	E	1	UNSIGNED_32	100	
<a href="#">C00076</a>	Current contr. reset time	Linear value	24499	5FB3	E	1	UNSIGNED_32	100	
<a href="#">C00077</a>	Field controller gain	Linear value	24498	5FB2	E	1	UNSIGNED_32	100	
<a href="#">C00078</a>	Field contr. reset time	Linear value	24497	5FB1	E	1	UNSIGNED_32	10	
<a href="#">C00079</a>	Motor magnetising inductance	Linear value	24496	5FB0	E	1	UNSIGNED_32	10	
<a href="#">C00080</a>	Number of resolver pole pairs	Linear value	24495	5FAF	E	1	UNSIGNED_32	1	CINH
<a href="#">C00081</a>	Rated motor power	Linear value	24494	5FAE	E	1	UNSIGNED_32	100	CINH
<a href="#">C00082</a>	Motor rotor resistance	Linear value	24493	5FAD	E	1	UNSIGNED_32	10000	
<a href="#">C00083</a>	Motor rotor time constant	Linear value	24492	5FAC	E	1	UNSIGNED_32	100	
<a href="#">C00084</a>	Motor stator resistance	Linear value	24491	5FAB	E	1	UNSIGNED_32	10000	CINH
<a href="#">C00085</a>	Motor stator leakage inductance	Linear value	24490	5FAA	E	1	UNSIGNED_32	1000	CINH
<a href="#">C00087</a>	Rated motor speed	Linear value	24488	5FA8	E	1	UNSIGNED_32	1	CINH
<a href="#">C00088</a>	Rated motor current	Linear value	24487	5FA7	E	1	UNSIGNED_32	100	CINH
<a href="#">C00089</a>	Rated motor frequency	Linear value	24486	5FA6	E	1	UNSIGNED_32	10	CINH
<a href="#">C00090</a>	Rated motor voltage	Linear value	24485	5FA5	E	1	UNSIGNED_32	1	CINH
<a href="#">C00091</a>	Motor cosine phi	Linear value	24484	5FA4	E	1	UNSIGNED_32	100	CINH
<a href="#">C00092</a>	Motor magnetising current	Linear value	24483	5FA3	E	1	UNSIGNED_32	100	
<a href="#">C00093</a>	Field weakening for SM	Selection list	24482	5FA2	E	1	UNSIGNED_32	1	
<a href="#">C00099</a>	Firmware version	String	24476	5F9C	E	1	VISIBLE_STRING [12]		
<a href="#">C00100</a>	Resolution	Linear value	24475	5F9B	E	1	UNSIGNED_32	1	CINH
<a href="#">C00105</a>	Decel. time - quick stop	Linear value	24470	5F96	E	1	UNSIGNED_32	1000	
<a href="#">C00106</a>	Quick stop S-ramp time	Linear value	24469	5F95	E	1	UNSIGNED_32	100	
<a href="#">C00107</a>	Ref. for quick stop dec. time	Selection list	24468	5F94	E	1	UNSIGNED_8	1	
<a href="#">C00114</a>	Digital input x - terminal pol.	Linear value	24461	5F8D	A	8	UNSIGNED_8	1	
<a href="#">C00118</a>	Digital output x - terminal pol.	Linear value	24457	5F89	A	4	UNSIGNED_8	1	
<a href="#">C00120</a>	Motor overload protection (l*xt)	Linear value	24455	5F87	E	1	UNSIGNED_32	1	
<a href="#">C00121</a>	Motor temp. warning threshold	Linear value	24454	5F86	E	1	UNSIGNED_32	1	
<a href="#">C00122</a>	Heatsink temp. warn. threshold	Linear value	24453	5F85	E	1	UNSIGNED_32	1	
<a href="#">C00123</a>	Device utilisation warning threshold	Linear value	24452	5F84	E	1	UNSIGNED_32	1	
<a href="#">C00126</a>	CPU temp. warning threshold	Linear value	24449	5F81	E	1	UNSIGNED_32	1	
<a href="#">C00127</a>	Mot. overload warning threshold	Linear value	24448	5F80	E	1	UNSIGNED_32	1	
<a href="#">C00128</a>	Therm. motor time constant	Linear value	24447	5F7F	A	2	UNSIGNED_32	10	
<a href="#">C00129</a>	Brake resistance value	Linear value	24446	5F7E	E	1	INTEGER_32	10	
<a href="#">C00130</a>	Rated brake resistor power	Linear value	24445	5F7D	E	1	INTEGER_32	1	
<a href="#">C00131</a>	Rated quantity of heat for brake res.	Linear value	24444	5F7C	E	1	INTEGER_32	1	
<a href="#">C00133</a>	Ref.: Brake chopper utilisation	Selection list	24442	5F7A	E	1	UNSIGNED_8	1	

code	Name	Parameter type	Index		Data					
			dec	hex	DS	DA	Data type	Factor	CINH	
<a href="#">C00134</a>	Min. brake resistance	Linear value	24441	5F79	E	1	INTEGER_32	10		
<a href="#">C00137</a>	Brake transistor utilisation	Linear value	24438	5F76	E	1	INTEGER_32	1		
<a href="#">C00138</a>	Brake resistor utilisation	Linear value	24437	5F75	E	1	INTEGER_32	1		
<a href="#">C00142</a>	Autom. restart after mains ON	Selection list	24433	5F71	E	1	UNSIGNED_32	1		
<a href="#">C00150</a>	Status word device control 1	Bit coded	24425	5F69	E	1	BITFIELD_16	1		
<a href="#">C00155</a>	Status word device control 2	Bit coded	24420	5F64	E	1	BITFIELD_16	1		
<a href="#">C00156</a>	Status/Control word MCTRL	Linear value	24419	5F63	A	2	UNSIGNED_32	1		
<a href="#">C00158</a>	Controller inhibit by (source)	Bit coded	24417	5F61	E	1	BITFIELD_16	1		
<a href="#">C00159</a>	Quick stop by (source)	Bit coded	24416	5F60	E	1	BITFIELD_16	1		
<a href="#">C00162</a>	Masked error number	Linear value	24413	5F5D	A	3	UNSIGNED_32	1		
<a href="#">C00166</a>	Error description	String	24409	5F59	E	1	VISIBLE_STRING [64]			
<a href="#">C00168</a>	Error number	Linear value	24407	5F57	E	1	UNSIGNED_32	1		
<a href="#">C00169</a>	Logbook event filter	Bit coded	24406	5F56	E	1	BITFIELD_32	1		
<a href="#">C00173</a>	Mains voltage	Selection list	24402	5F52	E	1	UNSIGNED_8	1		
<a href="#">C00174</a>	Undervoltage (LU) threshold	Linear value	24401	5F51	E	1	UNSIGNED_32	1		
<a href="#">C00178</a>	Elapsed-hour meter	Linear value	24397	5F4D	E	1	UNSIGNED_32	1		
<a href="#">C00179</a>	Power-on time meter	Linear value	24396	5F4C	E	1	UNSIGNED_32	1		
<a href="#">C00180</a>	Service code	String	24395	5F4B	E	1	VISIBLE_STRING [192]			
<a href="#">C00181</a>	Red. brake chopper threshold	Linear value	24394	5F4A	E	1	UNSIGNED_32	1		
<a href="#">C00182</a>	Time for device search function	Linear value	24393	5F49	E	1	UNSIGNED_16	1		
<a href="#">C00183</a>	Device status	Selection list	24392	5F48	E	1	UNSIGNED_32	1		
<a href="#">C00185</a>	Mains recov. detect. threshold	Linear value	24390	5F46	E	1	UNSIGNED_32	1		
<a href="#">C00186</a>	ENP: Identified motor type	String	24389	5F45	E	1	VISIBLE_STRING [19]			
<a href="#">C00187</a>	ENP: Identified serial number	String	24388	5F44	E	1	VISIBLE_STRING [22]			
<a href="#">C00188</a>	ENP: Status	Selection list	24387	5F43	E	1	UNSIGNED_8	1		
<a href="#">C00199</a>	Device name	String	24376	5F38	E	1	VISIBLE_STRING [128]			
<a href="#">C00200</a>	Firmware product type	String	24375	5F37	E	1	VISIBLE_STRING [18]			
<a href="#">C00201</a>	Firmware compilation date	String	24374	5F36	E	1	VISIBLE_STRING [21]			
<a href="#">C00202</a>	Autom. ENP data transfer	Selection list	24373	5F35	E	1	UNSIGNED_32	1		
<a href="#">C00203</a>	HW product types	String	24372	5F34	A	9	VISIBLE_STRING [18]			
<a href="#">C00204</a>	HW serial numbers	String	24371	5F33	A	9	VISIBLE_STRING [22]			
<a href="#">C00205</a>	HW descriptions	String	24370	5F32	A	6	VISIBLE_STRING [18]			
<a href="#">C00206</a>	HW manufacturing data	String	24369	5F31	A	8	VISIBLE_STRING [20]			
<a href="#">C00208</a>	HW manufacturer	String	24367	5F2F	A	6	VISIBLE_STRING [20]			
<a href="#">C00209</a>	HW countries of origin	String	24366	5F2E	A	6	VISIBLE_STRING [4]			
<a href="#">C00210</a>	HW versions	String	24365	5F2D	A	6	VISIBLE_STRING [5]			
<a href="#">C00211</a>	Application: Version	String	24364	5F2C	E	1	VISIBLE_STRING [12]			
<a href="#">C00212</a>	Application: Type code	String	24363	5F2B	E	1	VISIBLE_STRING [20]			
<a href="#">C00213</a>	Application: compilation date	String	24362	5F2A	E	1	VISIBLE_STRING [21]			
<a href="#">C00214</a>	Required safety module	Selection list	24361	5F29	E	1	UNSIGNED_8	1	CINH	
<a href="#">C00218</a>	Application: ID number	Linear value	24357	5F25	E	1	UNSIGNED_32	1		
<a href="#">C00220</a>	Memory module Firmw. Rev.	Linear value	24355	5F23	E	1	UNSIGNED_32	1		
<a href="#">C00227</a>	Behav. at parameter set changeover	Selection list	24348	5F1C	A	2	UNSIGNED_32	1		
<a href="#">C00254</a>	Phase controller gain	Linear value	24321	5F01	E	1	UNSIGNED_32	100		
<a href="#">C00270</a>	Freq. - current setpoint filter	Linear value	24305	5EF1	A	2	UNSIGNED_32	10		
<a href="#">C00271</a>	Width - current setp. filter	Linear value	24304	5EF0	A	2	UNSIGNED_32	10		
<a href="#">C00272</a>	Depth - current setp. filter	Linear value	24303	5EEF	A	2	UNSIGNED_32	1		
<a href="#">C00273</a>	Moment of inertia	Linear value	24302	5EEE	A	2	UNSIGNED_32	100		
<a href="#">C00274</a>	Max. acceleration change	Linear value	24301	5EED	E	1	UNSIGNED_32	10		
<a href="#">C00275</a>	Signal source - speed setpoint	Selection list	24300	5EEC	E	1	UNSIGNED_16	1		
<a href="#">C00276</a>	Signal source - torque setpoint	Selection list	24299	5EEB	E	1	UNSIGNED_16	1		

code	Name	Parameter type	Index		Data				
			dec	hex	DS	DA	Data type	Factor	CINH
<a href="#">C00280</a>	Filter time const. DC detection	Linear value	24295	5EE7	E	1	UNSIGNED_32	10	
<a href="#">C00281</a>	Filter for PWM adjustment	Selection list	24294	5EE6	E	1	UNSIGNED_8	1	
<a href="#">C00311</a>	CAN TPDO1 mask byte x	Bit coded	24264	5EC8	A	8	BITFIELD_8	1	
<a href="#">C00312</a>	CAN TPDO2 mask byte x	Bit coded	24263	5EC7	A	8	BITFIELD_8	1	
<a href="#">C00313</a>	CAN TPDO3 mask byte x	Bit coded	24262	5EC6	A	8	BITFIELD_8	1	
<a href="#">C00314</a>	CAN TPDO4 mask byte x	Bit coded	24261	5EC5	A	8	BITFIELD_8	1	
<a href="#">C00320</a>	CAN TPDOx identifier	Bit coded	24255	5EBF	A	4	BITFIELD_32	1	
<a href="#">C00321</a>	CAN RPDOx identifier	Bit coded	24254	5EBE	A	4	BITFIELD_32	1	
<a href="#">C00322</a>	CAN TPDOx Tx mode	Linear value	24253	5EBD	A	4	UNSIGNED_8	1	
<a href="#">C00323</a>	CAN RPDOx Rx mode	Linear value	24252	5EBC	A	4	UNSIGNED_8	1	
<a href="#">C00324</a>	CAN TPDOx delay time	Linear value	24251	5EBB	A	4	UNSIGNED_16	1	
<a href="#">C00343</a>	CAN TPDO counter	Linear value	24232	5EA8	A	4	UNSIGNED_32	1	
<a href="#">C00344</a>	CAN RPDO counter	Linear value	24231	5EA7	A	4	UNSIGNED_32	1	
<a href="#">C00345</a>	CAN error	Selection list	24230	5EA6	E	1	UNSIGNED_8	1	
<a href="#">C00346</a>	CAN heartbeat activity	Bit coded	24229	5EA5	E	1	BITFIELD_32	1	
<a href="#">C00347</a>	CAN heartbeat status	Selection list	24228	5EA4	A	32	UNSIGNED_8	1	
<a href="#">C00348</a>	CAN status DIP switch	Selection list	24227	5EA3	E	1	UNSIGNED_8	1	
<a href="#">C00349</a>	CAN setting - DIP switch	Linear value	24226	5EA2	A	2	UNSIGNED_8	1	
<a href="#">C00350</a>	CAN node address	Linear value	24225	5EA1	E	1	UNSIGNED_8	1	
<a href="#">C00351</a>	CAN baud rate	Selection list	24224	5EA0	E	1	UNSIGNED_8	1	
<a href="#">C00352</a>	CAN slave/master	Selection list	24223	5E9F	E	1	UNSIGNED_8	1	
<a href="#">C00356</a>	CAN TPDOx cycle time	Linear value	24219	5E9B	A	4	UNSIGNED_16	1	
<a href="#">C00357</a>	CAN RPDOx monitoring time	Linear value	24218	5E9A	A	4	UNSIGNED_16	1	
<a href="#">C00359</a>	CAN status	Selection list	24216	5E98	E	1	UNSIGNED_8	1	
<a href="#">C00360</a>	CAN telegram and error counter	Linear value	24215	5E97	A	8	UNSIGNED_16	1	
<a href="#">C00361</a>	CAN bus load	Linear value	24214	5E96	A	6	UNSIGNED_32	1	
<a href="#">C00367</a>	CAN SYNC Rx identifier	Linear value	24208	5E90	E	1	UNSIGNED_32	1	
<a href="#">C00368</a>	CAN SYNC Tx identifier	Linear value	24207	5E8F	E	1	UNSIGNED_32	1	
<a href="#">C00369</a>	CAN sync transmission cycle time	Linear value	24206	5E8E	A	3	UNSIGNED_16	1	
<a href="#">C00372</a>	CAN SDO server Rx identifier	Bit coded	24203	5E8B	A	10	BITFIELD_32	1	
<a href="#">C00373</a>	CAN SDO server Tx identifier	Bit coded	24202	5E8A	A	10	BITFIELD_32	1	
<a href="#">C00374</a>	CAN SDO client node address	Linear value	24201	5E89	A	10	UNSIGNED_8	1	
<a href="#">C00375</a>	CAN SDO client Rx identifier	Bit coded	24200	5E88	A	10	BITFIELD_32	1	
<a href="#">C00376</a>	CAN SDO client Tx identifier	Bit coded	24199	5E87	A	10	BITFIELD_32	1	
<a href="#">C00377</a>	CAN SDO server node address	Linear value	24198	5E86	A	10	UNSIGNED_8	1	
<a href="#">C00378</a>	CAN delay boot-up - Operational	Linear value	24197	5E85	E	1	UNSIGNED_16	1	
<a href="#">C00381</a>	CAN Heartbeat producer time	Linear value	24194	5E82	E	1	UNSIGNED_16	1	
<a href="#">C00382</a>	CAN guard time	Linear value	24193	5E81	E	1	UNSIGNED_16	1	
<a href="#">C00383</a>	CAN life time factor	Linear value	24192	5E80	E	1	UNSIGNED_8	1	
<a href="#">C00385</a>	CAN heartbeat consumer time	Bit coded	24190	5E7E	A	32	BITFIELD_32	1	
<a href="#">C00386</a>	CAN node guarding	Bit coded	24189	5E7D	A	32	BITFIELD_32	1	
<a href="#">C00387</a>	CAN Node Guarding Activity	Bit coded	24188	5E7C	E	1	BITFIELD_32	1	
<a href="#">C00388</a>	CAN node guarding status	Selection list	24187	5E7B	A	32	UNSIGNED_8	1	
<a href="#">C00390</a>	CAN error register (DS301V402)	Bit coded	24185	5E79	E	1	BITFIELD_8	1	
<a href="#">C00391</a>	CAN emergency object	Bit coded	24184	5E78	E	1	BITFIELD_32	1	
<a href="#">C00392</a>	CAN emergency delay time	Linear value	24183	5E77	E	1	UNSIGNED_16	1	
<a href="#">C00393</a>	CAN bus scan result	Linear value	24182	5E76	A	128	UNSIGNED_8	1	
<a href="#">C00394</a>	CAN predefined error field (DS301V402)	Linear value	24181	5E75	A	10	UNSIGNED_32	1	
<a href="#">C00398</a>	Test mode motor control	Selection list	24177	5E71	E	1	UNSIGNED_32	1	CINH
<a href="#">C00399</a>	Settings for test mode	Linear value	24176	5E70	A	2	INTEGER_32	10	

code	Name	Parameter type	Index		Data					
			dec	hex	DS	DA	Data type	Factor	CINH	
<a href="#">C00412</a>	Hiperface: Initialisation time	Linear value	24163	5E63	E	1	UNSIGNED_32	1		
<a href="#">C00413</a>	Hiperface: detected TypeCode	Linear value	24162	5E62	E	1	UNSIGNED_32	1		
<a href="#">C00414</a>	Hiperface: TypeCode	Linear value	24161	5E61	E	1	UNSIGNED_32	1		
<a href="#">C00415</a>	Hiperface: Number of revolutions	Linear value	24160	5E60	E	1	UNSIGNED_32	1		
<a href="#">C00417</a>	Dynamic of resolver evaluation	Linear value	24158	5E5E	E	1	UNSIGNED_32	1		
<a href="#">C00418</a>	Activate resolver error compensation	Selection list	24157	5E5D	E	1	UNSIGNED_8	1		
<a href="#">C00420</a>	Number of encoder increments	Linear value	24155	5E5B	E	1	UNSIGNED_16	1	CINH	
<a href="#">C00421</a>	Encoder voltage	Linear value	24154	5E5A	E	1	UNSIGNED_16	10	CINH	
<a href="#">C00422</a>	Encoder type	Selection list	24153	5E59	E	1	UNSIGNED_16	1	CINH	
<a href="#">C00423</a>	SSI encoder: Bit rate	Linear value	24152	5E58	E	1	UNSIGNED_32	1	CINH	
<a href="#">C00424</a>	Ssi-encoder: Data word length	Linear value	24151	5E57	E	1	UNSIGNED_32	1	CINH	
<a href="#">C00427</a>	TTL encoder signal evaluation	Selection list	24148	5E54	E	1	UNSIGNED_16	1	CINH	
<a href="#">C00435</a>	SSI encoder: Partword starting position	Linear value	24140	5E4C	A	8	UNSIGNED_8	1		
<a href="#">C00436</a>	SSI encoder: Partword length	Linear value	24139	5E4B	A	8	UNSIGNED_8	1		
<a href="#">C00437</a>	SSI encoder: Partword data coding	Selection list	24138	5E4A	A	8	UNSIGNED_8	1		
<a href="#">C00443</a>	Status: Digital inputs	Linear value	24132	5E44	A	12	UNSIGNED_8	1		
<a href="#">C00444</a>	Status: Digital outputs	Linear value	24131	5E43	A	18	UNSIGNED_8	1		
<a href="#">C00464</a>	Keypad: Mode	Selection list	24111	5E2F	E	1	UNSIGNED_16	1		
<a href="#">C00465</a>	Keypad: Time-out welcome screen	Selection list	24110	5E2E	E	1	UNSIGNED_8	1		
<a href="#">C00466</a>	Keypad: Default parameter	Linear value	24109	5E2D	E	1	UNSIGNED_16	1		
<a href="#">C00467</a>	Keypad: Default welcome screen	Selection list	24108	5E2C	E	1	UNSIGNED_8	1		
<a href="#">C00469</a>	Keypad: Fct. STOP key	Selection list	24106	5E2A	E	1	UNSIGNED_8	1		
<a href="#">C00490</a>	Position encoder selection	Selection list	24085	5E15	E	1	UNSIGNED_16	1	CINH	
<a href="#">C00494</a>	Motor standstill time constant	Linear value	24081	5E11	E	1	UNSIGNED_32	1		
<a href="#">C00495</a>	Motor encoder selection	Selection list	24080	5E10	E	1	UNSIGNED_16	1	CINH	
<a href="#">C00497</a>	Act. speed value time constant	Linear value	24078	5E0E	E	1	UNSIGNED_32	10		
<a href="#">C00569</a>	Resp. to brake trans. Ixt > C00570	Selection list	24006	5DC6	E	1	UNSIGNED_32	1		
<a href="#">C00570</a>	Warning thres. brake transistor	Linear value	24005	5DC5	E	1	UNSIGNED_32	1		
<a href="#">C00571</a>	Resp. to brake res. i <sup>2</sup> t > C00572	Selection list	24004	5DC4	E	1	UNSIGNED_32	1		
<a href="#">C00572</a>	Warning thres. brake resistor	Linear value	24003	5DC3	E	1	UNSIGNED_32	1		
<a href="#">C00573</a>	Resp. to brake transistor overload	Selection list	24002	5DC2	E	1	UNSIGNED_32	1		
<a href="#">C00574</a>	Resp. to brake resist. overtemp.	Selection list	24001	5DC1	E	1	UNSIGNED_32	1		
<a href="#">C00576</a>	Speed monitoring tolerance	Linear value	23999	5DBF	E	1	UNSIGNED_32	1		
<a href="#">C00577</a>	Field weakening controller gain	Linear value	23998	5DBE	E	1	UNSIGNED_32	1000		
<a href="#">C00578</a>	Field weak. contr. reset time	Linear value	23997	5DBD	E	1	UNSIGNED_32	10		
<a href="#">C00579</a>	Resp. to speed monitoring	Selection list	23996	5DBC	E	1	UNSIGNED_32	1		
<a href="#">C00580</a>	Resp. to encoder open circuit	Selection list	23995	5DBB	E	1	UNSIGNED_32	1		
<a href="#">C00581</a>	Resp. to external fault	Selection list	23994	5DBA	E	1	UNSIGNED_32	1		
<a href="#">C00582</a>	Resp. to heatsink temp. > C00122	Selection list	23993	5DB9	E	1	UNSIGNED_32	1		
<a href="#">C00583</a>	Resp. to motor KTY overtemp.	Selection list	23992	5DB8	E	1	UNSIGNED_32	1		
<a href="#">C00584</a>	Resp. to motor temp. > C00121	Selection list	23991	5DB7	E	1	UNSIGNED_32	1		
<a href="#">C00585</a>	Resp. to motor overtemp. PTC	Selection list	23990	5DB6	E	1	UNSIGNED_32	1		
<a href="#">C00586</a>	Resp. to resolver open circuit	Selection list	23989	5DB5	E	1	UNSIGNED_32	1		
<a href="#">C00587</a>	Fan control status	Bit coded	23988	5DB4	E	1	BITFIELD_8	1		
<a href="#">C00588</a>	Resp. to failure t. sensor drive	Selection list	23987	5DB3	E	1	UNSIGNED_32	1		
<a href="#">C00589</a>	Resp. to CPU temperature > C00126	Selection list	23986	5DB2	E	1	UNSIGNED_32	1		
<a href="#">C00591</a>	Resp. to CAN RPDOx error	Selection list	23984	5DB0	A	4	UNSIGNED_8	1		
<a href="#">C00594</a>	Response to temp. sensor motor X7/ X8	Selection list	23981	5DAD	E	1	UNSIGNED_32	1		
<a href="#">C00595</a>	Resp. to CAN bus OFF	Selection list	23980	5DAC	E	1	UNSIGNED_8	1		
<a href="#">C00596</a>	Threshold max. speed reached	Linear value	23979	5DAB	E	1	UNSIGNED_32	1		

code	Name	Parameter type	Index		Data				
			dec	hex	DS	DA	Data type	Factor	CINH
<a href="#">C00597</a>	Resp. to motor phase failure	Selection list	23978	5DAA	E	1	UNSIGNED_32	1	
<a href="#">C00598</a>	Resp. to open circuit AIN1	Selection list	23977	5DA9	E	1	UNSIGNED_32	1	
<a href="#">C00599</a>	Motor phase failure threshold	Linear value	23976	5DA8	E	1	INTEGER_32	10	
<a href="#">C00600</a>	Resp. to DC bus overvoltage	Selection list	23975	5DA7	E	1	UNSIGNED_32	1	
<a href="#">C00601</a>	Resp. to encoder comm. error	Selection list	23974	5DA6	E	1	UNSIGNED_32	1	
<a href="#">C00604</a>	Resp. to device monit. > C00123	Selection list	23971	5DA3	E	1	UNSIGNED_32	1	
<a href="#">C00606</a>	Resp. to motor overload > C00127	Selection list	23969	5DA1	E	1	UNSIGNED_32	1	
<a href="#">C00607</a>	Resp. to max. speed reached	Selection list	23968	5DA0	E	1	UNSIGNED_32	1	
<a href="#">C00610</a>	Resp. to failure heatsink fan	Selection list	23965	5D9D	E	1	UNSIGNED_32	1	
<a href="#">C00611</a>	Resp. to failure integral fan	Selection list	23964	5D9C	E	1	UNSIGNED_32	1	
<a href="#">C00612</a>	Resp. to CAN node guarding error	Selection list	23963	5D9B	A	32	UNSIGNED_8	1	
<a href="#">C00613</a>	Resp. to CAN Heartbeat error	Selection list	23962	5D9A	A	32	UNSIGNED_8	1	
<a href="#">C00614</a>	Resp. to CAN life guarding error	Selection list	23961	5D99	E	1	UNSIGNED_8	1	
<a href="#">C00615</a>	Resp. to imp. device config.	Selection list	23960	5D98	A	5	UNSIGNED_32	1	
<a href="#">C00618</a>	No. of CRC cycles	Linear value	23957	5D95	E	1	UNSIGNED_32	1	
<a href="#">C00619</a>	Resp. to motor current > C00620	Selection list	23956	5D94	E	1	UNSIGNED_32	1	
<a href="#">C00620</a>	Ultimate motor current I_ult	Linear value	23955	5D93	E	1	UNSIGNED_32	10	
<a href="#">C00621</a>	Resp. to encoder pulse deviation	Selection list	23954	5D92	E	1	UNSIGNED_32	1	
<a href="#">C00625</a>	CAN behaviour in case of fault	Selection list	23950	5D8E	E	1	UNSIGNED_8	1	
<a href="#">C00635</a>	Resp to new firmw. standard dev.	Selection list	23940	5D84	E	1	UNSIGNED_32	1	
<a href="#">C00636</a>	Resp. to new module in MXI1	Selection list	23939	5D83	E	1	UNSIGNED_32	1	
<a href="#">C00637</a>	Resp. to new module in MXI2	Selection list	23938	5D82	E	1	UNSIGNED_32	1	
<a href="#">C00640</a>	Resp. to PLI monitoring	Selection list	23935	5D7F	E	1	UNSIGNED_32	1	
<a href="#">C00641</a>	PLI 360° current amplitude	Linear value	23934	5D7E	E	1	UNSIGNED_32	1	
<a href="#">C00642</a>	PLI 360° ramp time	Linear value	23933	5D7D	E	1	UNSIGNED_32	1	
<a href="#">C00643</a>	PLI 360° traversing direction	Selection list	23932	5D7C	E	1	UNSIGNED_32	1	
<a href="#">C00644</a>	PolePosId 360° fault tol.	Linear value	23931	5D7B	E	1	INTEGER_32	10	
<a href="#">C00645</a>	PolePosId 360° absolute cur. amp.	Linear value	23930	5D7A	E	1	UNSIGNED_32	100	
<a href="#">C00646</a>	PolePosId min.mov. cur. amp.	Linear value	23929	5D79	E	1	UNSIGNED_32	1	
<a href="#">C00647</a>	PolePosId min.mov. cur.rise rate	Linear value	23928	5D78	E	1	UNSIGNED_32	1	
<a href="#">C00648</a>	PLI min. motion gain	Linear value	23927	5D77	E	1	UNSIGNED_32	100	
<a href="#">C00649</a>	PLI min. motion reset time	Linear value	23926	5D76	E	1	UNSIGNED_32	100	
<a href="#">C00650</a>	PLI min. motion max. perm. motion	Linear value	23925	5D75	E	1	INTEGER_32	1	
<a href="#">C00651</a>	PolePosId min.mov. absolute cur. amp.	Linear value	23924	5D74	E	1	UNSIGNED_32	100	
<a href="#">C00691</a>	Total speed setpoint	Linear value	23884	5D4C	E	1	INTEGER_32	100	
<a href="#">C00692</a>	Speed setpoint [%]	Linear value	23883	5D4B	E	1	INTEGER_32	100	
<a href="#">C00693</a>	Actual speed [%]	Linear value	23882	5D4A	E	1	INTEGER_32	100	
<a href="#">C00694</a>	Speed controller output	Linear value	23881	5D49	E	1	INTEGER_32	100	
<a href="#">C00695</a>	Total torque setpoint	Linear value	23880	5D48	E	1	INTEGER_32	100	
<a href="#">C00696</a>	Torque setpoint [%]	Linear value	23879	5D47	E	1	INTEGER_32	100	
<a href="#">C00697</a>	Filtered torque setpoint	Linear value	23878	5D46	E	1	INTEGER_32	100	
<a href="#">C00698</a>	Actual torque [%]	Linear value	23877	5D45	E	1	INTEGER_32	100	
<a href="#">C00770</a>	MCTRL_dnMotorPosAct	Linear value	23805	5CFD	A	2	UNSIGNED_32	1	
<a href="#">C00771</a>	MCTRL_dnLoadPosAct	Linear value	23804	5CFC	A	2	UNSIGNED_32	1	
<a href="#">C00772</a>	MCTRL_dnMotorSpeedAct	Linear value	23803	5CFB	E	1	INTEGER_32	1	
<a href="#">C00773</a>	MCTRL_dnLoadSpeedAct	Linear value	23802	5CFA	E	1	INTEGER_32	1	
<a href="#">C00774</a>	MCTRL_dnTorqueAct	Linear value	23801	5CF9	E	1	INTEGER_32	100	
<a href="#">C00775</a>	MCTRL_dnOutputSpeedCtrl	Linear value	23800	5CF8	E	1	INTEGER_32	100	
<a href="#">C00776</a>	MCTRL_dnInputJerkCtrl	Linear value	23799	5CF7	E	1	INTEGER_32	100	
<a href="#">C00777</a>	MCTRL_dnInputTorqueCtrl	Linear value	23798	5CF6	E	1	INTEGER_32	100	
<a href="#">C00778</a>	MCTRL_dnFluxAct	Linear value	23797	5CF5	E	1	INTEGER_32	100	

code	Name	Parameter type	Index		Data				
			dec	hex	DS	DA	Data type	Factor	CINH
<a href="#">C00779</a>	MCTRL_dnDCBusVoltage	Linear value	23796	5CF4	E	1	INTEGER_32	1	
<a href="#">C00780</a>	MCTRL_dnImotAct	Linear value	23795	5CF3	E	1	INTEGER_32	100	
<a href="#">C00781</a>	MCTRL_dwMaxMotorSpeed	Linear value	23794	5CF2	E	1	UNSIGNED_32	1	
<a href="#">C00782</a>	MCTRL_dwMaxMotorTorque	Linear value	23793	5CF1	E	1	UNSIGNED_32	1000	
<a href="#">C00783</a>	MCTRL_dwMotorVoltageAct	Linear value	23792	5CF0	E	1	UNSIGNED_32	1	
<a href="#">C00784</a>	MCTRL_dnMotorFreqAct	Linear value	23791	5CEF	E	1	INTEGER_32	10	
<a href="#">C00786</a>	MCTRL_dnIxtLoad	Linear value	23789	5CED	E	1	INTEGER_32	100	
<a href="#">C00787</a>	MCTRL_dnFlyingSpeedAct	Linear value	23788	5CEC	E	1	INTEGER_32	1	
<a href="#">C00788</a>	MCTRL_dwMaxEffMotorTorque	Linear value	23787	5CEB	E	1	INTEGER_32	1000	
<a href="#">C00789</a>	MCTRL_dwMaxDeviceCurrent	Linear value	23786	5CEA	E	1	INTEGER_32	100	
<a href="#">C00790</a>	MCTRL_dnI2xtLoad	Linear value	23785	5CE9	E	1	INTEGER_32	100	
<a href="#">C00791</a>	MCTRL_dnDeltaMotorPos_p	Linear value	23784	5CE8	E	1	INTEGER_32	1	
<a href="#">C00792</a>	MCTRL_dnOutputPosCtrlMotor_s	Linear value	23783	5CE7	E	1	INTEGER_32	1	
<a href="#">C00800</a>	MCTRL_dnPosSet	Linear value	23775	5CDF	A	2	UNSIGNED_32	1	
<a href="#">C00802</a>	MCTRL_dnSpeedAdd	Linear value	23773	5CDD	E	1	INTEGER_32	1	
<a href="#">C00803</a>	MCTRL_dnTorqueAdd	Linear value	23772	5CDC	E	1	INTEGER_32	1000	
<a href="#">C00804</a>	MCTRL_dnAccelerationAdd	Linear value	23771	5CDB	E	1	INTEGER_32	1000	
<a href="#">C00805</a>	MCTRL_dnSpeedLowLimit	Linear value	23770	5CDA	E	1	INTEGER_32	1	
<a href="#">C00806</a>	MCTRL_dnTorqueLowLimit	Linear value	23769	5CD9	E	1	INTEGER_32	100	
<a href="#">C00807</a>	MCTRL_dnTorqueHighLimit	Linear value	23768	5CD8	E	1	INTEGER_32	100	
<a href="#">C00808</a>	MCTRL_dnPosCtrlOutLimit	Linear value	23767	5CD7	E	1	INTEGER_32	1	
<a href="#">C00809</a>	MCTRL_dnTorqueCtrlAdapt	Linear value	23766	5CD6	E	1	INTEGER_32	100	
<a href="#">C00810</a>	MCTRL_dnSpeedCtrlAdapt	Linear value	23765	5CD5	E	1	INTEGER_32	100	
<a href="#">C00811</a>	MCTRL_dnPosCtrlAdapt	Linear value	23764	5CD4	E	1	INTEGER_32	100	
<a href="#">C00812</a>	MCTRL_dnMotorPosRefValue	Linear value	23763	5CD3	A	2	UNSIGNED_32	1	
<a href="#">C00813</a>	MCTRL_dnLoadPosRefValue	Linear value	23762	5CD2	A	2	UNSIGNED_32	1	
<a href="#">C00814</a>	MCTRL_dnBoost	Linear value	23761	5CD1	E	1	INTEGER_32	1	
<a href="#">C00815</a>	MCTRL_dnSpeedCtrlIntegrator	Linear value	23760	5CD0	E	1	INTEGER_32	1000	
<a href="#">C00816</a>	MCTRL_dnFieldWeak	Linear value	23759	5CCF	E	1	INTEGER_32	100	
<a href="#">C00817</a>	MCTRL_dnSpeedSet_s	Linear value	23758	5CCE	E	1	INTEGER_32	1	
<a href="#">C00818</a>	MCTRL_dnMvorAdapt	Linear value	23757	5CCD	E	1	INTEGER_32	100	
<a href="#">C00854</a>	ID status	Linear value	23721	5CA9	E	1	UNSIGNED_32	1	
<a href="#">C00878</a>	Status DCTRL control input	Linear value	23697	5C91	A	5	UNSIGNED_8	1	
<a href="#">C00909</a>	Speed limitation	Linear value	23666	5C72	A	2	INTEGER_16	10	
<a href="#">C00950</a>	VFC: V/f characteristic shape	Selection list	23625	5C49	E	1	UNSIGNED_32	1	
<a href="#">C00951</a>	VFC: V/f base frequency	Linear value	23624	5C48	E	1	INTEGER_32	1	
<a href="#">C00952</a>	VFC: Frequency interpol. point n	Linear value	23623	5C47	A	11	INTEGER_32	1	CINH
<a href="#">C00953</a>	VFC: Voltage interpol. point n	Linear value	23622	5C46	A	11	INTEGER_32	100	CINH
<a href="#">C00954</a>	VFC: Activat. interpol. point n	Selection list	23621	5C45	A	11	UNSIGNED_32	1	CINH
<a href="#">C00955</a>	VFC: Vmax reduction	Linear value	23620	5C44	E	1	UNSIGNED_32	1	
<a href="#">C00957</a>	VFC: VVC current setpoint	Linear value	23618	5C42	E	1	INTEGER_32	100	
<a href="#">C00958</a>	VFC: VVC gain	Linear value	23617	5C41	E	1	UNSIGNED_32	100	
<a href="#">C00959</a>	VFC: VVC reset time	Linear value	23616	5C40	E	1	UNSIGNED_32	100	
<a href="#">C00960</a>	VFC: V/f voltage boost	Linear value	23615	5C3F	E	1	INTEGER_32	1	
<a href="#">C00961</a>	VFC: Load - cw/ccw-operation	Selection list	23614	5C3E	E	1	UNSIGNED_32	1	CINH
<a href="#">C00962</a>	VFC: Load adjustment	Linear value	23613	5C3D	E	1	UNSIGNED_32	100	
<a href="#">C00963</a>	VFC: Gain - lmax controller	Linear value	23612	5C3C	E	1	UNSIGNED_32	1000	
<a href="#">C00964</a>	VFC: Reset time - lmax controller	Linear value	23611	5C3B	E	1	UNSIGNED_32	10	
<a href="#">C00965</a>	VFC: Gain - slip compensation	Linear value	23610	5C3A	E	1	INTEGER_32	100	
<a href="#">C00966</a>	VFC: Time const. slip comp.	Linear value	23609	5C39	E	1	UNSIGNED_32	1	
<a href="#">C00967</a>	VFC: Gain - oscillation damping	Linear value	23608	5C38	E	1	INTEGER_32	1	

code	Name	Parameter type	Index		Data				
			dec	hex	DS	DA	Data type	Factor	CINH
<a href="#">C00968</a>	VFC: Time const. - oscill. damp.	Linear value	23607	5C37	E	1	INTEGER_32	1	
<a href="#">C00969</a>	VFC: Limitation - oscillation damping	Linear value	23606	5C36	E	1	INTEGER_32	10	
<a href="#">C00970</a>	VFC: ramp-end frequ. - oscill. damp.	Linear value	23605	5C35	E	1	INTEGER_32	1	
<a href="#">C00971</a>	VFC: Influence - speed controller	Linear value	23604	5C34	E	1	UNSIGNED_32	100	
<a href="#">C00972</a>	VFC: Gain - speed controller	Linear value	23603	5C33	E	1	UNSIGNED_32	1000	
<a href="#">C00973</a>	VFC: Reset time - speed contr.	Linear value	23602	5C32	E	1	UNSIGNED_32	10	
<a href="#">C00974</a>	DC brake: Current	Linear value	23601	5C31	E	1	INTEGER_32	100	
<a href="#">C00975</a>	DC brake: Current for quick stop	Linear value	23600	5C30	E	1	INTEGER_32	100	
<a href="#">C00976</a>	DC brake: Activat. by quick stop	Selection list	23599	5C2F	E	1	UNSIGNED_32	1	
<a href="#">C00977</a>	Min. inh-time aft. overvolt.	Linear value	23598	5C2E	E	1	UNSIGNED_32	1	
<a href="#">C00980</a>	VFC: Override point of field weakening	Linear value	23595	5C2B	E	1	INTEGER_32	1	
<a href="#">C00985</a>	SLVC: Gain of field current controller	Linear value	23590	5C26	E	1	UNSIGNED_32	100	
<a href="#">C00986</a>	SLVC: Gain of cross current controller	Linear value	23589	5C25	E	1	UNSIGNED_32	100	
<a href="#">C00987</a>	SLVC: Gain - torque controller	Linear value	23588	5C24	E	1	UNSIGNED_32	10000	
<a href="#">C00988</a>	SLVC: Torque controller reset time	Linear value	23587	5C23	E	1	UNSIGNED_32	100	
<a href="#">C00989</a>	SLVC: Time const.- Para. adj.	Linear value	23586	5C22	A	2	UNSIGNED_32	1	
<a href="#">C00990</a>	Flying restart: Activation	Selection list	23585	5C21	E	1	UNSIGNED_32	1	
<a href="#">C00991</a>	Flying restart: Current	Linear value	23584	5C20	E	1	INTEGER_32	1	
<a href="#">C00992</a>	Flying restart circuit: start frequency	Linear value	23583	5C1F	E	1	INTEGER_32	10	
<a href="#">C00993</a>	Flying restart: Integration time	Linear value	23582	5C1E	E	1	UNSIGNED_32	1	
<a href="#">C00994</a>	Flying restart: Min. deviation	Linear value	23581	5C1D	E	1	UNSIGNED_32	100	
<a href="#">C00995</a>	Flying restart: Delay time	Linear value	23580	5C1C	E	1	UNSIGNED_32	1	
<a href="#">C00998</a>	VFC: Frequency setpoint	Linear value	23577	5C19	E	1	INTEGER_32	10	
<a href="#">C01120</a>	Sync source	Selection list	23455	5B9F	E	1	UNSIGNED_8	1	
<a href="#">C01121</a>	Sync cycle time	Linear value	23454	5B9E	E	1	UNSIGNED_32	1	
<a href="#">C01122</a>	Sync phase position	Linear value	23453	5B9D	E	1	UNSIGNED_32	1	
<a href="#">C01123</a>	Sync tolerance	Linear value	23452	5B9C	E	1	UNSIGNED_32	1	
<a href="#">C01124</a>	Sync PLL increment	Selection list	23451	5B9B	E	1	UNSIGNED_8	1	
<a href="#">C01130</a>	CAN SYNC application cycle	Linear value	23445	5B95	E	1	UNSIGNED_16	1	
<a href="#">C01190</a>	Motor thermal sensor	Selection list	23385	5B59	E	1	UNSIGNED_32	1	
<a href="#">C01191</a>	Spec. characteristic: temperature	Linear value	23384	5B58	A	2	UNSIGNED_32	1	
<a href="#">C01192</a>	Spec. characteristic: resistance	Linear value	23383	5B57	A	2	UNSIGNED_32	1	
<a href="#">C01193</a>	Motor temp. feedback system	Selection list	23382	5B56	E	1	UNSIGNED_16	1	CINH
<a href="#">C01194</a>	Motor operating temperature	Linear value	23381	5B55	E	1	INTEGER_32	1	
<a href="#">C01195</a>	Influence winding I <sup>2</sup> t mon.	Linear value	23380	5B54	E	1	UNSIGNED_32	1	
<a href="#">C01196</a>	S1 torque characteristic I <sup>2</sup> t mon.	Linear value	23379	5B53	A	8	UNSIGNED_32	1	
<a href="#">C01197</a>	Starting value I <sup>2</sup> t monitoring	Linear value	23378	5B52	E	1	UNSIGNED_32	1	
<a href="#">C01198</a>	Async. motor: Stall protection	Linear value	23377	5B51	E	1	UNSIGNED_32	1	
<a href="#">C01199</a>	Enhanced power	Selection list	23376	5B50	E	1	UNSIGNED_32	1	CINH
<a href="#">C01200</a>	Dual motor temperature	Linear value	23375	5B4F	A	2	INTEGER_32	1	
<a href="#">C01201</a>	Delay time for fan start	Selection list	23374	5B4E	E	1	UNSIGNED_32	1	
<a href="#">C01203</a>	Counter: Brake chopper overload	Linear value	23372	5B4C	E	1	UNSIGNED_16	1	
<a href="#">C01204</a>	Counter: Ixt overload	Linear value	23371	5B4B	E	1	UNSIGNED_16	1	
<a href="#">C01205</a>	Counter: DC bus overvoltage	Linear value	23370	5B4A	E	1	UNSIGNED_16	1	
<a href="#">C01206</a>	Counter: Mains switching	Linear value	23369	5B49	E	1	UNSIGNED_16	1	
<a href="#">C01208</a>	Counter: Heatsink overtemp.	Linear value	23367	5B47	E	1	UNSIGNED_16	1	
<a href="#">C01209</a>	Counter: Housing overtemp.	Linear value	23366	5B46	E	1	UNSIGNED_16	1	
<a href="#">C01210</a>	Counter: internal	Linear value	23365	5B45	E	1	UNSIGNED_8	1	
<a href="#">C01212</a>	Counter: Power section overload	Linear value	23363	5B43	E	1	UNSIGNED_16	1	
<a href="#">C01214</a>	Internal clock	String	23361	5B41	E	1	VISIBLE_STRING [21]		
<a href="#">C01215</a>	Set time and date	Linear value	23360	5B40	A	6	UNSIGNED_16	1	

code	Name	Parameter type	Index		Data				
			dec	hex	DS	DA	Data type	Factor	CINH
<a href="#">C01230</a>	Resp. to comm. task overflow	Selection list	23345	5B31	E	1	UNSIGNED_8	1	
<a href="#">C01501</a>	Resp. to comm. error with MX1	Selection list	23074	5A22	E	1	UNSIGNED_32	1	
<a href="#">C01502</a>	Resp. to comm. error with MX12	Selection list	23073	5A21	E	1	UNSIGNED_32	1	
<a href="#">C01510</a>	Ethernet IP address client x	String	23065	5A19	A	3	VISIBLE_STRING [24]		
<a href="#">C01511</a>	Ethernet status client x	Selection list	23064	5A18	A	3	UNSIGNED_8	1	
<a href="#">C01700</a>	Energy: Mode inform.	Linear value	22875	595B	A	2	UNSIGNED_8	1	
<a href="#">C01701</a>	Energy: toff min	Linear value	22874	595A	A	1	UNSIGNED_32	1	
<a href="#">C01702</a>	Energy: toff	Linear value	22873	5959	A	1	UNSIGNED_32	1	
<a href="#">C01703</a>	Energy: ton	Linear value	22872	5958	A	1	UNSIGNED_32	1	
<a href="#">C01704</a>	Energy: Comp. to be switched off	Bit coded	22871	5957	A	1	BITFIELD_32	1	
<a href="#">C01705</a>	Energy: Power input	Linear value	22870	5956	A	1	UNSIGNED_32	1	
<a href="#">C01902</a>	Diagnostics X6: Max. baud rate	Selection list	22673	5891	E	1	UNSIGNED_32	1	
<a href="#">C01903</a>	Diagnostics X6: Change baud rate	Selection list	22672	5890	E	1	UNSIGNED_32	1	
<a href="#">C01905</a>	Diagnostics X6: Curr. baud rate	Linear value	22670	588E	E	1	UNSIGNED_32	1	
<a href="#">C02104</a>	Program auto-start	Selection list	22471	57C7	E	1	UNSIGNED_32	1	
<a href="#">C02108</a>	Program status	Selection list	22467	57C3	E	1	UNSIGNED_8	1	
<a href="#">C02109</a>	Program runtime	Linear value	22466	57C2	E	1	UNSIGNED_16	1	
<a href="#">C02110</a>	User code: Memory utilisation	Linear value	22465	57C1	E	1	UNSIGNED_32	1	
<a href="#">C02111</a>	Resp. to task overflow	Selection list	22464	57C0	E	1	UNSIGNED_8	1	
<a href="#">C02112</a>	B. code: Read non-vol. memory	Linear value	22463	57BF	E	1	UNSIGNED_32	1	
<a href="#">C02113</a>	Program name	String	22462	57BE	E	1	VISIBLE_STRING [32]		
<a href="#">C02119</a>	Active target ID	Linear value	22456	57B8	E	1	UNSIGNED_32	1	
<a href="#">C02121</a>	Runtime ApplicationTask	Linear value	22454	57B6	A	2	UNSIGNED_32	1	
<a href="#">C02122</a>	Runtime UserTask	Linear value	22453	57B5	A	2	UNSIGNED_32	1	
<a href="#">C02123</a>	Runtime IdleTask	Linear value	22452	57B4	A	2	UNSIGNED_32	1	
<a href="#">C02520</a>	Gearbox factor numerator: Motor	Linear value	22055	5627	E	1	INTEGER_32	1	CINH
<a href="#">C02521</a>	Gearbox factor denom.: Motor	Linear value	22054	5626	E	1	INTEGER_32	1	CINH
<a href="#">C02522</a>	Gearbox factor num.: Pos. enc.	Linear value	22053	5625	E	1	INTEGER_32	1	CINH
<a href="#">C02523</a>	Gearbox fac. denom.: Pos. enc.	Linear value	22052	5624	E	1	INTEGER_32	1	CINH
<a href="#">C02524</a>	Feed constant	Linear value	22051	5623	E	1	UNSIGNED_32	10000	CINH
<a href="#">C02525</a>	Unit	Selection list	22050	5622	E	1	UNSIGNED_32	1	
<a href="#">C02526</a>	User-defined unit	String	22049	5621	E	1	VISIBLE_STRING [8]		
<a href="#">C02527</a>	Motor mounting direction	Selection list	22048	5620	E	1	UNSIGNED_32	1	CINH
<a href="#">C02528</a>	Traversing range	Selection list	22047	561F	E	1	UNSIGNED_32	1	CINH
<a href="#">C02529</a>	Position encoder mounting direction	Selection list	22046	561E	E	1	UNSIGNED_32	1	CINH
<a href="#">C02530</a>	Active function state	Selection list	22045	561D	E	1	INTEGER_32	1	
<a href="#">C02531</a>	Gearbox factors (decimal)	Linear value	22044	561C	A	3	UNSIGNED_32	1000	
<a href="#">C02532</a>	Resolution of a unit	Linear value	22043	561B	E	1	UNSIGNED_32	10000	
<a href="#">C02533</a>	Time unit	Selection list	22042	561A	E	1	UNSIGNED_32	1	
<a href="#">C02534</a>	Time unit used	String	22041	5619	E	1	VISIBLE_STRING [8]		
<a href="#">C02535</a>	Unit used	String	22040	5618	E	1	VISIBLE_STRING [8]		
<a href="#">C02536</a>	Cycle length	Linear value	22039	5617	E	1	UNSIGNED_32	10000	CINH
<a href="#">C02537</a>	Speed unit	String	22038	5616	E	1	VISIBLE_STRING [16]		
<a href="#">C02538</a>	Acceleration unit	String	22037	5615	E	1	VISIBLE_STRING [16]		
<a href="#">C02539</a>	Maximum position that can be displayed	Linear value	22036	5614	E	1	INTEGER_32	10000	
<a href="#">C02540</a>	Max. presentable speed	Linear value	22035	5613	E	1	INTEGER_32	10000	
<a href="#">C02541</a>	Max. presentable acceleration	Linear value	22034	5612	E	1	INTEGER_32	10000	
<a href="#">C02542</a>	Load reference speed	Linear value	22033	5611	E	1	UNSIGNED_32	1000	
<a href="#">C02543</a>	Load reference torque	Linear value	22032	5610	E	1	UNSIGNED_32	1000	
<a href="#">C02544</a>	Reference speed	Linear value	22031	560F	E	1	INTEGER_32	10000	



code	Name	Parameter type	Index		Data				
			dec	hex	DS	DA	Data type	Factor	CINH
<a href="#">C02545</a>	Reference Jerktime	Linear value	22030	560E	E	1	UNSIGNED_32	1000	
<a href="#">C02547</a>	DI_dnState	Linear value	22028	560C	E	1	INTEGER_32	1	
<a href="#">C02548</a>	DI_bErrors	Selection list	22027	560B	A	4	UNSIGNED_32	1	
<a href="#">C02549</a>	Drive interface: Signals	Selection list	22026	560A	A	15	UNSIGNED_32	1	
<a href="#">C02550</a>	Setpoint interpolation	Selection list	22025	5609	A	3	UNSIGNED_32	1	
<a href="#">C02552</a>	Position setpoint (motor interface)	Linear value	22023	5607	E	1	INTEGER_32	10000	
<a href="#">C02553</a>	Position controller gain	Linear value	22022	5606	E	1	UNSIGNED_32	100	
<a href="#">C02554</a>	Position controller reset time	Linear value	22021	5605	E	1	UNSIGNED_32	1000	
<a href="#">C02555</a>	D component position controller	Linear value	22020	5604	E	1	UNSIGNED_32	1000	
<a href="#">C02556</a>	Pos. contr. limitation	Linear value	22019	5603	E	1	INTEGER_32	10000	
<a href="#">C02557</a>	Phase controller output	Linear value	22018	5602	E	1	INTEGER_32	10000	
<a href="#">C02558</a>	Position controller output	Linear value	22017	5601	E	1	INTEGER_32	10000	
<a href="#">C02559</a>	Internal torque limits	Linear value	22016	5600	A	2	INTEGER_32	100	
<a href="#">C02560</a>	Messages - motor interface	Linear value	22015	55FF	E	1	UNSIGNED_32	1	
<a href="#">C02561</a>	Speed feedforw. control gain	Linear value	22014	55FE	E	1	INTEGER_32	100	
<a href="#">C02562</a>	Filter time constant	Linear value	22013	55FD	E	1	UNSIGNED_32	1000	
<a href="#">C02564</a>	Service code	Bit coded	22011	55FB	E	1	BITFIELD_8	1	
<a href="#">C02567</a>	Control mode	Selection list	22008	55F8	E	1	UNSIGNED_32	1	
<a href="#">C02568</a>	Motor interface: % signals	Linear value	22007	55F7	A	10	INTEGER_32	100	
<a href="#">C02569</a>	Motor interface.: Dig. signals	Selection list	22006	55F6	A	16	UNSIGNED_32	1	
<a href="#">C02570</a>	Position control structure	Selection list	22005	55F5	E	1	UNSIGNED_32	1	CINH
<a href="#">C02572</a>	Speed setpoint (enc. eval.)	Linear value	22003	55F3	E	1	INTEGER_32	10000	
<a href="#">C02573</a>	Position setpoint (enc. eval.)	Linear value	22002	55F2	E	1	INTEGER_32	10000	
<a href="#">C02574</a>	Actual speed (enc. eval.)	Linear value	22001	55F1	E	1	INTEGER_32	10000	
<a href="#">C02575</a>	Actual position (enc. eval.)	Linear value	22000	55F0	E	1	INTEGER_32	10000	
<a href="#">C02576</a>	Following error	Linear value	21999	55EF	E	1	INTEGER_32	10000	
<a href="#">C02577</a>	External actual position	Linear value	21998	55EE	E	1	INTEGER_32	10000	
<a href="#">C02578</a>	Offset actual pos. value/setp.	Linear value	21997	55ED	E	1	INTEGER_32	10000	
<a href="#">C02579</a>	Encoder eval.: Dig. signals	Selection list	21996	55EC	A	4	UNSIGNED_32	1	
<a href="#">C02580</a>	Brake operating mode	Selection list	21995	55EB	E	1	UNSIGNED_32	1	CINH
<a href="#">C02581</a>	Threshold - brake activation	Linear value	21994	55EA	E	1	INTEGER_32	1	
<a href="#">C02582</a>	Brake resp. to pulse inhibit	Selection list	21993	55E9	E	1	UNSIGNED_32	1	
<a href="#">C02583</a>	Status input monitoring	Selection list	21992	55E8	E	1	UNSIGNED_32	1	
<a href="#">C02585</a>	Brake control polarity	Selection list	21990	55E6	E	1	UNSIGNED_32	1	
<a href="#">C02586</a>	Starting torque 1	Linear value	21989	55E5	E	1	INTEGER_32	100	
<a href="#">C02587</a>	Starting torque 2	Linear value	21988	55E4	E	1	INTEGER_32	100	
<a href="#">C02588</a>	Source of starting torque	Selection list	21987	55E3	E	1	UNSIGNED_32	1	
<a href="#">C02589</a>	Brake closing time	Linear value	21986	55E2	E	1	UNSIGNED_32	1	
<a href="#">C02590</a>	Brake opening time	Linear value	21985	55E1	E	1	UNSIGNED_32	1	
<a href="#">C02591</a>	Waiting time - status monitoring	Linear value	21984	55E0	E	1	UNSIGNED_32	1	
<a href="#">C02593</a>	Waiting time - brake activation	Linear value	21982	55DE	E	1	UNSIGNED_32	1000	
<a href="#">C02594</a>	Test torque	Linear value	21981	55DD	E	1	INTEGER_32	100	
<a href="#">C02595</a>	Permissible angle of rotation	Linear value	21980	55DC	E	1	INTEGER_32	1	
<a href="#">C02596</a>	Grinding speed	Linear value	21979	55 db	E	1	INTEGER_32	1	
<a href="#">C02597</a>	Accel./decel. time - grinding	Linear value	21978	55DA	E	1	UNSIGNED_32	1000	
<a href="#">C02598</a>	Grinding ON time	Linear value	21977	55D9	E	1	UNSIGNED_32	10	
<a href="#">C02599</a>	Grinding OFF time	Linear value	21976	55D8	E	1	UNSIGNED_32	10	
<a href="#">C02600</a>	Acceleration time feedf. control	Linear value	21975	55D7	E	1	UNSIGNED_32	1000	
<a href="#">C02601</a>	Reference for acceleration time of brake	Selection list	21974	55D6	E	1	UNSIGNED_32	1	
<a href="#">C02602</a>	Source for feedf. control brake	Selection list	21973	55D5	E	1	UNSIGNED_32	1	

code	Name	Parameter type	Index		Data				
			dec	hex	DS	DA	Data type	Factor	CINH
<a href="#">C02603</a>	Threshold 1 for opening brake	Linear value	21972	55D4	E	1	INTEGER_32	1	
<a href="#">C02604</a>	Threshold 2 for opening brake	Linear value	21971	55D3	E	1	INTEGER_32	1	
<a href="#">C02605</a>	Brake test - time	Linear value	21970	55D2	A	3	UNSIGNED_16	1000	
<a href="#">C02606</a>	Minimum starting torque	Linear value	21969	55D1	E	1	INTEGER_32	100	
<a href="#">C02607</a>	BRK_dnState	Linear value	21968	55D0	E	1	INTEGER_32	1	
<a href="#">C02608</a>	BRK_dnTorqueAdd_n	Linear value	21967	55CF	E	1	INTEGER_32	100	
<a href="#">C02609</a>	Brake control: Dig. signals	Selection list	21966	55CE	A	10	UNSIGNED_32	1	
<a href="#">C02610</a>	Deceleration time for stop	Linear value	21965	55CD	E	1	UNSIGNED_32	1000	
<a href="#">C02611</a>	S-ramp time for stop	Linear value	21964	55CC	E	1	UNSIGNED_32	1000	
<a href="#">C02612</a>	Ref. for decel. time of stop	Selection list	21963	55CB	E	1	UNSIGNED_32	1	
<a href="#">C02616</a>	STP_dnState	Linear value	21959	55C7	E	1	INTEGER_32	1	
<a href="#">C02617</a>	STP_bStopActive	Selection list	21958	55C6	E	1	UNSIGNED_32	1	
<a href="#">C02619</a>	Quick stop: Dig. signals	Selection list	21956	55C4	A	5	UNSIGNED_32	1	
<a href="#">C02620</a>	Manual jog: Speed 1	Linear value	21955	55C3	E	1	INTEGER_32	10000	
<a href="#">C02621</a>	Manual jog: Speed 2	Linear value	21954	55C2	E	1	INTEGER_32	10000	
<a href="#">C02622</a>	Manual jog: Acceleration	Linear value	21953	55C1	E	1	INTEGER_32	10000	
<a href="#">C02623</a>	Manual jog: Deceleration	Linear value	21952	55C0	E	1	INTEGER_32	10000	
<a href="#">C02624</a>	Manual jog: S-ramp time	Linear value	21951	55BF	E	1	UNSIGNED_32	1000	
<a href="#">C02625</a>	Manual jog: Step size	Linear value	21950	55BE	E	1	INTEGER_32	10000	
<a href="#">C02626</a>	Manual jog: Index stop position	Linear value	21949	55BD	A	16	INTEGER_32	1	
<a href="#">C02627</a>	Manual jog: Selected stop position	Linear value	21948	55BC	A	16	INTEGER_32	10000	
<a href="#">C02637</a>	MAN_dnSpeedOverride_n	Linear value	21938	55B2	E	1	INTEGER_32	100	
<a href="#">C02638</a>	Manual jog: Status	Linear value	21937	55B1	E	1	INTEGER_32	1	
<a href="#">C02639</a>	Manual jog: Dig. signals	Selection list	21936	55B0	A	9	UNSIGNED_32	1	
<a href="#">C02640</a>	Homing mode	Selection list	21935	55AF	E	1	UNSIGNED_32	1	
<a href="#">C02641</a>	Action after detect home position	Selection list	21934	55AE	E	1	UNSIGNED_32	1	
<a href="#">C02642</a>	Home position	Linear value	21933	55AD	E	1	INTEGER_32	10000	
<a href="#">C02643</a>	Homing: target position	Linear value	21932	55AC	E	1	INTEGER_32	10000	
<a href="#">C02644</a>	Homing: Speed 1	Linear value	21931	55AB	E	1	INTEGER_32	10000	
<a href="#">C02645</a>	Homing: Acceleration 1	Linear value	21930	55AA	E	1	INTEGER_32	10000	
<a href="#">C02646</a>	Homing: veloc. 2	Linear value	21929	55A9	E	1	INTEGER_32	10000	
<a href="#">C02647</a>	Homing: acceleration 2	Linear value	21928	55A8	E	1	INTEGER_32	10000	
<a href="#">C02648</a>	Homing: S-ramp time	Linear value	21927	55A7	E	1	INTEGER_32	1	
<a href="#">C02649</a>	Homing: Torque limit	Linear value	21926	55A6	E	1	INTEGER_32	100	
<a href="#">C02650</a>	Homing: Blocking time	Linear value	21925	55A5	E	1	UNSIGNED_32	1000	
<a href="#">C02651</a>	Homing: TP configuration	Linear value	21924	55A4	E	1	UNSIGNED_32	1	
<a href="#">C02652</a>	Home pos. following mains switching	Selection list	21923	55A3	E	1	UNSIGNED_32	1	
<a href="#">C02653</a>	Max. rot. ang. aft. mns. swtch.	Linear value	21922	55A2	E	1	INTEGER_32	1	
<a href="#">C02655</a>	HM_dnSpeedOverride_n	Linear value	21920	55A0	E	1	INTEGER_32	100	
<a href="#">C02656</a>	Actual position (homing)	Linear value	21919	559F	E	1	INTEGER_32	10000	
<a href="#">C02657</a>	HM_dnState	Linear value	21918	559E	E	1	INTEGER_32	1	
<a href="#">C02658</a>	HM_dnHomePos_p	Linear value	21917	559D	E	1	INTEGER_32	10000	
<a href="#">C02659</a>	Homing: Dig. signals	Selection list	21916	559C	A	9	UNSIGNED_32	1	
<a href="#">C02670</a>	Tolerance for POS_bActPosInTarget	Linear value	21905	5591	E	1	INTEGER_32	10000	
<a href="#">C02671</a>	Tolerance for POS_bDriveInTarget	Linear value	21904	5590	E	1	INTEGER_32	10000	
<a href="#">C02672</a>	Hysteresis for POS_bDriveInTarget	Linear value	21903	558F	E	1	INTEGER_32	10000	
<a href="#">C02673</a>	Activate DriveInTarget Modulo	Selection list	21902	558E	E	1	UNSIGNED_32	1	
<a href="#">C02674</a>	POS_dwActualProfileNumber	Linear value	21901	558D	E	1	UNSIGNED_32	1	
<a href="#">C02675</a>	POS_dnState	Linear value	21900	558C	E	1	INTEGER_32	1	
<a href="#">C02676</a>	POS_dnProfileSpeed_s	Linear value	21899	558B	E	1	INTEGER_32	10000	
<a href="#">C02677</a>	Positioning: % signals	Linear value	21898	558A	A	3	INTEGER_32	100	

code	Name	Parameter type	Index		Data				
			dec	hex	DS	DA	Data type	Factor	CINH
<a href="#">C02678</a>	Positioning: Pos. signals	Linear value	21897	5589	A	4	INTEGER_32	10000	
<a href="#">C02679</a>	Positioning: Dig. signals	Selection list	21896	5588	A	12	UNSIGNED_32	1	
<a href="#">C02680</a>	Source position setpoint	Selection list	21895	5587	E	1	UNSIGNED_32	1	
<a href="#">C02681</a>	Source add. speed	Selection list	21894	5586	E	1	UNSIGNED_32	1	
<a href="#">C02685</a>	PF_dnMotorAcc_x	Linear value	21890	5582	E	1	INTEGER_32	10	
<a href="#">C02686</a>	PF_dnSpeedAdd1_s	Linear value	21889	5581	E	1	INTEGER_32	10	
<a href="#">C02687</a>	Position follower: % signals	Linear value	21888	5580	A	2	INTEGER_32	100	
<a href="#">C02688</a>	PF_dnPositionSet_p	Linear value	21887	557F	E	1	INTEGER_32	10000	
<a href="#">C02689</a>	Position follower: Dig. signals	Selection list	21886	557E	A	2	UNSIGNED_32	1	
<a href="#">C02692</a>	SF_dnMotorAcc_x	Linear value	21883	557B	E	1	INTEGER_32	10	
<a href="#">C02693</a>	SF_dnSpeedAdd_s	Linear value	21882	557A	E	1	INTEGER_32	10	
<a href="#">C02694</a>	Speed follower: % signals	Linear value	21881	5579	A	2	INTEGER_32	100	
<a href="#">C02695</a>	Speed follower: Dig. signals	Selection list	21880	5578	A	2	UNSIGNED_32	1	
<a href="#">C02698</a>	Torque follower: % signals	Linear value	21877	5575	A	3	INTEGER_32	100	
<a href="#">C02699</a>	Torque follower: Dig. signals	Selection list	21876	5574	A	2	UNSIGNED_32	1	
<a href="#">C02700</a>	Software limit positions active	Selection list	21875	5573	E	1	UNSIGNED_32	1	
<a href="#">C02701</a>	Software limit positions	Linear value	21874	5572	A	2	INTEGER_32	10000	
<a href="#">C02702</a>	Limitations effective	Selection list	21873	5571	E	1	UNSIGNED_32	1	
<a href="#">C02703</a>	Max. speed	Linear value	21872	5570	E	1	INTEGER_32	10000	
<a href="#">C02704</a>	Max. speed [rpm]	Linear value	21871	556F	E	1	INTEGER_32	10	
<a href="#">C02705</a>	Max. acceleration	Linear value	21870	556E	E	1	INTEGER_32	10000	
<a href="#">C02706</a>	Min. S-ramp time	Linear value	21869	556D	E	1	UNSIGNED_32	1	
<a href="#">C02707</a>	Permissible direction of rotation	Selection list	21868	556C	E	1	UNSIGNED_32	1	
<a href="#">C02708</a>	Limited speed	Linear value	21867	556B	A	4	INTEGER_32	10000	
<a href="#">C02709</a>	Limited speed [rpm]	Linear value	21866	556 A	A	4	INTEGER_32	10	
<a href="#">C02710</a>	Delay lim. speed	Linear value	21865	5569	A	4	UNSIGNED_32	10000	
<a href="#">C02711</a>	S-ramp time lim. speed	Linear value	21864	5568	A	4	UNSIGNED_32	1	
<a href="#">C02712</a>	Decel. time lim. speed	Linear value	21863	5567	A	4	UNSIGNED_32	1	
<a href="#">C02713</a>	Max. distance manual control	Linear value	21862	5566	E	1	UNSIGNED_32	10000	
<a href="#">C02714</a>	Max. dist. manual jog [inc.]	Linear value	21861	5565	E	1	UNSIGNED_32	1	
<a href="#">C02715</a>	Limitation active	Selection list	21860	5564	E	1	UNSIGNED_32	1	
<a href="#">C02716</a>	Resp. to limitation	Selection list	21859	5563	A	3	UNSIGNED_32	1	
<a href="#">C02717</a>	LIM_dwControl	Linear value	21858	5562	E	1	UNSIGNED_32	1	
<a href="#">C02718</a>	LIM_dnState	Linear value	21857	5561	E	1	INTEGER_32	1	
<a href="#">C02719</a>	Limiter: Dig. signals	Selection list	21856	5560	A	3	UNSIGNED_32	1	
<a href="#">C02720</a>	Software limit position monitoring	Selection list	21855	555F	E	1	UNSIGNED_32	1	
<a href="#">C02730</a>	Analog inputs: Gain	Linear value	21845	5555	A	2	INTEGER_32	100	
<a href="#">C02731</a>	Analog inputs: Offset	Linear value	21844	5554	A	2	INTEGER_32	100	
<a href="#">C02732</a>	Analog inputs: Dead band	Linear value	21843	5553	A	2	INTEGER_32	100	
<a href="#">C02733</a>	Analog outputs: Gain	Linear value	21842	5552	A	2	INTEGER_32	100	
<a href="#">C02734</a>	Analog outputs: Offset	Linear value	21841	5551	A	2	INTEGER_32	100	
<a href="#">C02760</a>	Activate Encoder	Selection list	21815	5537	E	1	UNSIGNED_32	1	
<a href="#">C02761</a>	Resolution Multiturn	Linear value	21814	5536	E	1	UNSIGNED_32	1	
<a href="#">C02762</a>	Encoder position	Linear value	21813	5535	E	1	INTEGER_32	1	
<a href="#">C02763</a>	Encoder revolution	Linear value	21812	5534	E	1	INTEGER_32	1	
<a href="#">C02764</a>	Encoder speed	Linear value	21811	5533	E	1	INTEGER_32	10	
<a href="#">C02765</a>	ENC_bError	Selection list	21810	5532	E	1	UNSIGNED_32	1	
<a href="#">C02770</a>	Operating mode	Selection list	21805	552D	A	5	UNSIGNED_32	1	
<a href="#">C02771</a>	Frequency	Linear value	21804	552C	A	4	INTEGER_32	10	
<a href="#">C02772</a>	Start angle	Linear value	21803	552B	A	4	INTEGER_32	10	
<a href="#">C02773</a>	Current	Linear value	21802	552A	A	4	INTEGER_32	100	

code	Name	Parameter type	Index		Data				
			dec	hex	DS	DA	Data type	Factor	CINH
<a href="#">C02774</a>	Acceleration time	Linear value	21801	5529	A	4	INTEGER_32	1000	
<a href="#">C02775</a>	Deceleration time	Linear value	21800	5528	A	4	INTEGER_32	1000	
<a href="#">C02776</a>	Duration time	Linear value	21799	5527	A	4	INTEGER_32	1000	
<a href="#">C02779</a>	Mol_SetpointCurrent	Linear value	21796	5524	E	1	UNSIGNED_32	100	
<a href="#">C02780</a>	Mol_dnState	Linear value	21795	5523	E	1	INTEGER_32	1	
<a href="#">C02781</a>	ManualLogOpenLoop: Dig. signals	Selection list	21794	5522	A	8	UNSIGNED_32	1	
<a href="#">C02785</a>	Activation of PPI	Selection list	21790	551E	E	1	UNSIGNED_32	1	
<a href="#">C02786</a>	Mode of PPI	Selection list	21789	551D	E	1	UNSIGNED_32	1	
<a href="#">C02787</a>	Ppi_dnState	Linear value	21788	551C	E	1	INTEGER_32	1	
<a href="#">C02788</a>	PolePosition Setpoint	Linear value	21787	551B	E	1	INTEGER_32	10	
<a href="#">C02789</a>	PolePositionIdentification: Dig. signals	Selection list	21786	551A	A	9	UNSIGNED_32	1	
<a href="#">C02800</a>	Analog input x: Input signal	Linear value	21775	550F	A	2	INTEGER_16	1	
<a href="#">C02801</a>	Analog output x: Output signal	Linear value	21774	550E	A	2	INTEGER_16	1	
<a href="#">C02802</a>	Status word: Digital outputs	Bit coded	21773	550D	E	1	BITFIELD_32	1	
<a href="#">C02803</a>	Status word: Digital inputs	Bit coded	21772	550C	E	1	BITFIELD_32	1	
<a href="#">C02810</a>	Touch probe x: Delay time	Linear value	21765	5505	A	10	UNSIGNED_32	1	
<a href="#">C02830</a>	Digital inputs: Delay time	Selection list	21745	54F1	A	8	UNSIGNED_8	1	
<a href="#">C02853</a>	Lss sat. characteristic	Linear value	21722	54DA	A	17	UNSIGNED_16	1	CINH
<a href="#">C02855</a>	lmax Lss saturation characteristic	Linear value	21720	54D8	E	1	UNSIGNED_32	10	CINH
<a href="#">C02859</a>	Activate Lss saturation charact.	Selection list	21716	54D4	E	1	UNSIGNED_8	1	CINH
<a href="#">C02860</a>	Rr adjustment	Linear value	21715	54D3	E	1	UNSIGNED_32	100	
<a href="#">C02861</a>	Lh adjustment	Linear value	21714	54D2	E	1	UNSIGNED_32	100	
<a href="#">C02862</a>	Resolver: Gain	Linear value	21713	54D1	A	2	UNSIGNED_16	1	
<a href="#">C02863</a>	Resolver: Angle correction	Linear value	21712	54D0	E	1	INTEGER_16	1	
<a href="#">C02865</a>	Adaptation of Ur	Linear value	21710	54CE	E	1	UNSIGNED_32	100	
<a href="#">C02867</a>	Motor phase failure volt. threshold	Linear value	21708	54CC	E	1	INTEGER_32	10	
<a href="#">C02871</a>	Voltage reserve	Linear value	21704	54C8	E	1	UNSIGNED_32	1	
<a href="#">C02872</a>	PLI 360° result in C58	Selection list	21703	54C7	E	1	UNSIGNED_32	1	
<a href="#">C02900</a>	User Password	String	21675	54AB	E	1	VISIBLE_STRING [22]		
<a href="#">C02901</a>	CamMemory	Linear value	21674	54AA	A	3	UNSIGNED_32	1	
<a href="#">C02902</a>	Time stamp of cam data	Linear value	21673	54A9	A	4	UNSIGNED_32	1	
<a href="#">C02903</a>	GUID cam data		21672	54A8	A	4	OCTET_STRING [16]		
<a href="#">C02905</a>	Online change mode	Selection list	21670	54A6	E	1	UNSIGNED_32	1	
<a href="#">C02906</a>	Online change status	Selection list	21669	54A5	E	1	UNSIGNED_32	1	
<a href="#">C02908</a>	Number of products	Linear value	21667	54A3	E	1	UNSIGNED_32	1	
<a href="#">C02909</a>	Active Product	Linear value	21666	54A2	E	1	UNSIGNED_32	1	
<a href="#">C02910</a>	Product designation	String	21665	54A1	E	1	VISIBLE_STRING [16]		
<a href="#">C02911</a>	Product Choice	Linear value	21664	54A0	E	1	UNSIGNED_32	1	
<a href="#">C02912</a>	Number of products	Linear value	21663	549F	E	1	UNSIGNED_32	1	
<a href="#">C02919</a>	Number of curve tracks	Linear value	21656	5498	E	1	UNSIGNED_32	1	
<a href="#">C02920</a>	Cam Track Choice	Linear value	21655	5497	E	1	UNSIGNED_32	1	
<a href="#">C02921</a>	Cam Track Type	Selection list	21654	5496	E	1	UNSIGNED_32	1	
<a href="#">C02922</a>	Number of Cam Data Points	Linear value	21653	5495	E	1	UNSIGNED_32	1	
<a href="#">C02923</a>	Cam Data Point Choice	Linear value	21652	5494	E	1	UNSIGNED_32	1	
<a href="#">C02924</a>	Change Cam Data Point X	Linear value	21651	5493	E	1	INTEGER_32	10000	
<a href="#">C02925</a>	Change Cam Data Point Y	Linear value	21650	5492	E	1	INTEGER_32	10000	
<a href="#">C02926</a>	Torque feedforward control value	Linear value	21649	5491	E	1	INTEGER_32	100	
<a href="#">C02927</a>	Auto Inc Cam Data Points	Selection list	21648	5490	E	1	UNSIGNED_32	1	
<a href="#">C02939</a>	Number of Cont Tracks	Linear value	21636	5484	E	1	UNSIGNED_32	1	
<a href="#">C02940</a>	Cont Track Choice	Linear value	21635	5483	E	1	UNSIGNED_32	1	
<a href="#">C02941</a>	Cam type	Selection list	21634	5482	E	1	UNSIGNED_32	1	

code	Name	Parameter type	Index		Data				
			dec	hex	DS	DA	Data type	Factor	CINH
<a href="#">C02942</a>	Number of Cont Data Points	Linear value	21633	5481	E	1	UNSIGNED_32	1	
<a href="#">C02943</a>	Cont Data Point Choice	Linear value	21632	5480	E	1	UNSIGNED_32	1	
<a href="#">C02944</a>	Cont Pos X0	Linear value	21631	547F	E	1	INTEGER_32	10000	
<a href="#">C02945</a>	Cont Pos X1	Linear value	21630	547E	E	1	INTEGER_32	10000	
<a href="#">C02946</a>	Cont Time	Linear value	21629	547D	E	1	UNSIGNED_32	10000	
<a href="#">C02959</a>	Number of Position Tracks	Linear value	21616	5470	E	1	UNSIGNED_32	1	
<a href="#">C02960</a>	Pos Track Choice	Linear value	21615	546F	E	1	UNSIGNED_32	1	
<a href="#">C02962</a>	Number of Pos Data Points	Linear value	21613	546D	E	1	UNSIGNED_32	1	
<a href="#">C02963</a>	Pos Data Point Choice	Linear value	21612	546C	E	1	UNSIGNED_32	1	
<a href="#">C02964</a>	Change Pos Data Point X	Linear value	21611	546B	E	1	INTEGER_32	10000	
<a href="#">C02965</a>	Change Pos Data Point Y	Linear value	21610	546A	E	1	INTEGER_32	10000	

## Figures

"CAN on board" system bus [295](#)  
"LS\_SafetyModuleInterface" system block [370](#)  
"Online" tab [558](#)

## A

Absolute value encoder  
  Communication error (error message) [663](#)  
Accel./decel. time - grinding (C02597) [876](#)  
Acceleration has been limited (error message) [711](#)  
Acceleration reduction [385](#)  
Acceleration time (C02774) [906](#)  
Acceleration time feedf. control (C02600) [876](#)  
Acceleration unit (C02538) [864](#)  
Access protection [560](#)  
Action after detect Home position (C02641) [888](#)  
Activate DriveInTarget Modulo (C02673) [892](#)  
Activate encoder (C02760) [904](#)  
Activate Lss sat. char. (C02859) [916](#)  
Activate resolver error compensation (C00418) [798](#)  
Active application (C00007) [745](#)  
Active function state (C02530) [862](#)  
Active Product (C02909) [920](#)  
Active target ID (C02119) [859](#)  
Actual position (enc. eval.) (C02575) [872](#)  
Actual position (homing) (C02656) [890](#)  
Actual speed (enc. eval.) (C02574) [871](#)  
Actual speed [%] (C00693) [822](#)  
Actual speed [rpm] (C00051) [747](#)  
Actual speed filter [152](#), [179](#)  
Actual speed value outside the tolerance (C00576) (error message) [662](#)  
Actual torque [%] (C00698) [823](#)  
Actual value detection [152](#)  
Adaptation of Ur (C02865) [917](#)  
Analog input 1  
  Master current < 4 mA (error message) [675](#)  
Analog input x  
  Input signal (C02800) [909](#)  
Analog inputs [277](#)  
  Dead band (C02732) [903](#)  
  Gain (C02730) [902](#)  
  Offset (C02731) [903](#)  
Analog output x  
  Output signal (C02801) [910](#)  
Analog outputs [280](#)  
  Gain (C02733) [903](#)  
  Offset (C02734) [903](#)  
Angular drift monitoring (encoder) [267](#)  
Application  
  Compiler date (C00213) [770](#)  
  ID number (C00218) [771](#)  
  Type code (C00212) [770](#)  
  Version (C00211) [770](#)

Application and device are incompatible (error message) [683](#)  
Application has started (error message) [649](#)  
Application is stopped (error message) [648](#), [649](#)  
Application notes [17](#)  
Application selection (C00005) [744](#)  
Application unit [36](#)  
ApplicationTask  
  Overflow (error message) [647](#)  
Asynchronous machine in the field weakening range [159](#)  
Asynchronous motor  
  Stall protection (C01198) [848](#)  
Auto Inc Cam Data Points [570](#)  
Auto Inc Cam Data Points (C02927) [923](#)  
Auto increment CAM grid points [570](#)  
Autom. ENP data transfer (C00202) [768](#)  
Autom. restart after mains ON (C00142) [759](#)  
Automatic restart [107](#)  
Automatic switching frequency reduction [110](#)

## B

B. code  
  Read non-vol. memory (C02112) [859](#)  
Band-stop filter [153](#)  
Basic drive functions [377](#)  
Basic function "Limiter" [370](#)  
Basic functions [377](#)  
Behaviour after task overflow [109](#), [293](#)  
Behaviour due to change of parameter set (C00227) [772](#)  
Behaviour of the outputs after a system event [293](#)  
Block function in wrong MEC task (error message) [693](#)  
Brake chopper [269](#), [272](#)  
  Ixt > C00570 (error message) [672](#)  
Brake chopper monitoring [272](#)  
Brake chopper utilisation [272](#)  
Brake closing time (C02589) [874](#)  
Brake control [521](#)  
  Dig. signals (C02609) [879](#)  
Brake control polarity (C02585) [874](#)  
Brake module [528](#), [529](#), [530](#)  
Brake opening time (C02590) [875](#)  
Brake resistance value (C00129) [757](#)  
Brake resistor [273](#)  
  I<sup>2</sup>t overload (error message) [664](#)  
  I<sup>2</sup>t > C00572 (error message) [672](#)  
Brake resistor monitoring [273](#)  
Brake resistor utilisation [273](#)  
Brake resistor utilisation (C00138) [758](#)  
Brake resp. to pulse inhibit (C02582) [873](#)  
Brake test - time (C02605) [878](#)  
Brake transistor [269](#)  
  Ixt overload (error message) [664](#)  
  Overcurrent (error message) [665](#)  
Brake transistor utilisation (C00137) [758](#)  
Braking operation [269](#)

# Index

---

Breakpoint reached (error message) [648](#)

BRK\_dnState (C02607) [878](#)

BRK\_dnTorqueAdd\_n (C02608) [878](#)

## C

C100 [754](#)

C105 [754](#)

C106 [754](#)

C107 [755](#)

C11 [745](#)

C1120 [843](#)

C1121 [843](#)

C1122 [844](#)

C1123 [844](#)

C1124 [845](#)

C1125 [845](#)

C1126 [845](#)

C1127 [846](#)

C1128 [846](#)

C1129 [846](#)

C1130 [846](#)

C114 [755](#)

C118 [755](#)

C1190 [846](#)

C1191 [847](#)

C1192 [847](#)

C1193 [847](#)

C1194 [847](#)

C1195 [848](#)

C1196 [848](#)

C1197 [848](#)

C1198 [848](#)

C1199 [849](#)

C120 [755](#)

C1200 [849](#)

C1201 [849](#)

C1203 [850](#)

C1204 [850](#)

C1205 [850](#)

C1206 [850](#)

C1208 [850](#)

C1209 [850](#)

C121 [756](#)

C1210 [851](#)

C1211 [851](#)

C1212 [851](#)

C1213 [851](#)

C1214 [851](#)

C1215 [852](#)

C1217 [852](#)

C1218 [852](#)

C122 [756](#)

C1220 [852](#)

C1221 [852](#)

C1222 [853](#)

C1223 [853](#)

C123 [756](#)

C1230 [853](#)

C126 [756](#)

C127 [756](#)

C128 [757](#)

C129 [757](#)

C130 [757](#)

C131 [757](#)

C132 [757](#)

C133 [758](#)

C134 [758](#)

C137 [758](#)

C138 [758](#)

C142 [759](#)

C150 [759](#)

C1501 [853](#)

C1502 [854](#)

C1510 [854](#)

C1511 [854](#)

C155 [760](#)

C156 [760](#)

C158 [761](#)

C159 [762](#)

C162 [762](#)

C166 [762](#)

C167 [763](#)

C168 [763](#)

C169 [763](#)

C1700 [855](#)

C1701 [855](#)

C1702 [855](#)

C1703 [855](#)

C1704 [856](#)

C1705 [857](#)

C171 [763](#)

C173 [764](#)

C174 [765](#)

C175 [765](#)

C176 [765](#)

C177 [765](#)

C178 [765](#)

C179 [765](#)

C18 [746](#)

C180 [766](#)

C181 [766](#)

C182 [766](#)

C183 [766](#)

C185 [767](#)

C186 [767](#)

C187 [767](#)

# Index

---

C188	<a href="#">767</a>	C2533	<a href="#">863</a>
C19	<a href="#">746</a>	C2534	<a href="#">863</a>
C1902	<a href="#">857</a>	C2535	<a href="#">863</a>
C1903	<a href="#">857</a>	C2536	<a href="#">864</a>
C1905	<a href="#">857</a>	C2537	<a href="#">864</a>
C198	<a href="#">767</a>	C2538	<a href="#">864</a>
C199	<a href="#">767</a>	C2539	<a href="#">864</a>
C2	<a href="#">731</a>	C254	<a href="#">772</a>
C200	<a href="#">767</a>	C2540	<a href="#">864</a>
C201	<a href="#">768</a>	C2541	<a href="#">864</a>
C202	<a href="#">768</a>	C2542	<a href="#">865</a>
C203	<a href="#">768</a>	C2543	<a href="#">865</a>
C204	<a href="#">768</a>	C2544	<a href="#">865</a>
C205	<a href="#">769</a>	C2545	<a href="#">865</a>
C206	<a href="#">769</a>	C2547	<a href="#">865</a>
C208	<a href="#">769</a>	C2548	<a href="#">866</a>
C209	<a href="#">770</a>	C2549	<a href="#">866</a>
C210	<a href="#">770</a>	C2550	<a href="#">867</a>
C2104	<a href="#">858</a>	C2552	<a href="#">867</a>
C2108	<a href="#">858</a>	C2553	<a href="#">867</a>
C2109	<a href="#">858</a>	C2554	<a href="#">867</a>
C211	<a href="#">770</a>	C2555	<a href="#">867</a>
C2110	<a href="#">858</a>	C2556	<a href="#">868</a>
C2111	<a href="#">859</a>	C2557	<a href="#">868</a>
C2112	<a href="#">859</a>	C2558	<a href="#">868</a>
C2113	<a href="#">859</a>	C2559	<a href="#">868</a>
C2119	<a href="#">859</a>	C2560	<a href="#">868</a>
C212	<a href="#">770</a>	C2561	<a href="#">869</a>
C2121	<a href="#">859</a>	C2562	<a href="#">869</a>
C2122	<a href="#">860</a>	C2564	<a href="#">869</a>
C2123	<a href="#">860</a>	C2567	<a href="#">869</a>
C213	<a href="#">770</a>	C2568	<a href="#">870</a>
C214	<a href="#">371</a> , <a href="#">771</a>	C2569	<a href="#">870</a>
C217	<a href="#">771</a>	C2570	<a href="#">871</a>
C218	<a href="#">771</a>	C2571	<a href="#">871</a>
C219	<a href="#">771</a>	C2572	<a href="#">871</a>
C22	<a href="#">746</a>	C2573	<a href="#">871</a>
C220	<a href="#">771</a>	C2574	<a href="#">871</a>
C225	<a href="#">771</a>	C2575	<a href="#">872</a>
C227	<a href="#">772</a>	C2576	<a href="#">872</a>
C2520	<a href="#">860</a>	C2577	<a href="#">872</a>
C2521	<a href="#">860</a>	C2578	<a href="#">872</a>
C2522	<a href="#">860</a>	C2579	<a href="#">872</a>
C2523	<a href="#">861</a>	C2580	<a href="#">873</a>
C2524	<a href="#">861</a>	C2581	<a href="#">873</a>
C2525	<a href="#">861</a>	C2582	<a href="#">873</a>
C2526	<a href="#">861</a>	C2583	<a href="#">873</a>
C2527	<a href="#">861</a>	C2585	<a href="#">874</a>
C2528	<a href="#">862</a>	C2586	<a href="#">874</a>
C2529	<a href="#">862</a>	C2587	<a href="#">874</a>
C2530	<a href="#">862</a>	C2588	<a href="#">874</a>
C2531	<a href="#">863</a>	C2589	<a href="#">874</a>
C2532	<a href="#">863</a>	C2590	<a href="#">875</a>



# Index

---

C2591	<a href="#">875</a>	C2659	<a href="#">891</a>
C2593	<a href="#">875</a>	C2670	<a href="#">891</a>
C2594	<a href="#">875</a>	C2671	<a href="#">892</a>
C2595	<a href="#">875</a>	C2672	<a href="#">892</a>
C2596	<a href="#">876</a>	C2673	<a href="#">892</a>
C2597	<a href="#">876</a>	C2674	<a href="#">892</a>
C2598	<a href="#">876</a>	C2675	<a href="#">893</a>
C2599	<a href="#">876</a>	C2676	<a href="#">893</a>
C2600	<a href="#">876</a>	C2677	<a href="#">893</a>
C2601	<a href="#">877</a>	C2678	<a href="#">893</a>
C2602	<a href="#">877</a>	C2679	<a href="#">894</a>
C2603	<a href="#">877</a>	C2680	<a href="#">894</a>
C2604	<a href="#">877</a>	C2681	<a href="#">894</a>
C2605	<a href="#">878</a>	C2685	<a href="#">895</a>
C2606	<a href="#">878</a>	C2686	<a href="#">895</a>
C2607	<a href="#">878</a>	C2687	<a href="#">895</a>
C2608	<a href="#">878</a>	C2688	<a href="#">895</a>
C2609	<a href="#">879</a>	C2689	<a href="#">895</a>
C2610	<a href="#">879</a>	C2692	<a href="#">896</a>
C2611	<a href="#">879</a>	C2693	<a href="#">896</a>
C2612	<a href="#">879</a>	C2694	<a href="#">896</a>
C2616	<a href="#">880</a>	C2695	<a href="#">896</a>
C2617	<a href="#">880</a>	C2698	<a href="#">897</a>
C2619	<a href="#">880</a>	C2699	<a href="#">897</a>
C2620	<a href="#">880</a>	C270	<a href="#">772</a>
C2621	<a href="#">881</a>	C2700	<a href="#">897</a>
C2622	<a href="#">881</a>	C2701	<a href="#">897</a>
C2623	<a href="#">881</a>	C2702	<a href="#">898</a>
C2624	<a href="#">881</a>	C2703	<a href="#">898</a>
C2625	<a href="#">881</a>	C2704	<a href="#">898</a>
C2626	<a href="#">882</a>	C2705	<a href="#">898</a>
C2627	<a href="#">882</a>	C2706	<a href="#">898</a>
C2637	<a href="#">882</a>	C2707	<a href="#">899</a>
C2638	<a href="#">883</a>	C2708	<a href="#">899</a>
C2639	<a href="#">883</a>	C2709	<a href="#">899</a>
C2640	<a href="#">886</a>	C271	<a href="#">772</a>
C2641	<a href="#">888</a>	C2710	<a href="#">900</a>
C2642	<a href="#">888</a>	C2711	<a href="#">900</a>
C2643	<a href="#">888</a>	C2712	<a href="#">900</a>
C2644	<a href="#">888</a>	C2713	<a href="#">900</a>
C2645	<a href="#">888</a>	C2714	<a href="#">901</a>
C2646	<a href="#">889</a>	C2715	<a href="#">901</a>
C2647	<a href="#">889</a>	C2716	<a href="#">901</a>
C2648	<a href="#">889</a>	C2717	<a href="#">901</a>
C2649	<a href="#">889</a>	C2718	<a href="#">902</a>
C2650	<a href="#">889</a>	C2719	<a href="#">902</a>
C2651	<a href="#">890</a>	C272	<a href="#">773</a>
C2652	<a href="#">890</a>	C2720	<a href="#">902</a>
C2653	<a href="#">890</a>	C273	<a href="#">773</a>
C2655	<a href="#">890</a>	C2730	<a href="#">902</a>
C2656	<a href="#">890</a>	C2731	<a href="#">903</a>
C2657	<a href="#">891</a>	C2732	<a href="#">903</a>
C2658	<a href="#">891</a>	C2733	<a href="#">903</a>

# Index

---

C2734	<a href="#">903</a>	C2870	<a href="#">918</a>
C274	<a href="#">773</a>	C2871	<a href="#">918</a>
C275	<a href="#">773</a>	C2872	<a href="#">918</a>
C276	<a href="#">774</a>	C2900	<a href="#">918</a>
C2760	<a href="#">904</a>	C2901	<a href="#">919</a>
C2761	<a href="#">904</a>	C2902	<a href="#">919</a>
C2762	<a href="#">904</a>	C2903	<a href="#">919</a>
C2763	<a href="#">904</a>	C2905	<a href="#">920</a>
C2764	<a href="#">904</a>	C2906	<a href="#">920</a>
C2765	<a href="#">905</a>	C2908	<a href="#">920</a>
C2770	<a href="#">905</a>	C2909	<a href="#">920</a>
C2771	<a href="#">905</a>	C2910	<a href="#">921</a>
C2772	<a href="#">906</a>	C2911	<a href="#">921</a>
C2773	<a href="#">906</a>	C2912	<a href="#">921</a>
C2774	<a href="#">906</a>	C2919	<a href="#">921</a>
C2775	<a href="#">907</a>	C2920	<a href="#">921</a>
C2776	<a href="#">907</a>	C2921	<a href="#">922</a>
C2779	<a href="#">907</a>	C2922	<a href="#">922</a>
C2780	<a href="#">907</a>	C2923	<a href="#">922</a>
C2781	<a href="#">908</a>	C2924	<a href="#">922</a>
C2785	<a href="#">908</a>	C2925	<a href="#">922</a>
C2786	<a href="#">908</a>	C2926	<a href="#">923</a>
C2787	<a href="#">908</a>	C2927	<a href="#">923</a>
C2788	<a href="#">909</a>	C2939	<a href="#">923</a>
C2789	<a href="#">909</a>	C2940	<a href="#">923</a>
C280	<a href="#">774</a>	C2941	<a href="#">924</a>
C2800	<a href="#">909</a>	C2942	<a href="#">924</a>
C2801	<a href="#">910</a>	C2943	<a href="#">924</a>
C2802	<a href="#">911</a>	C2944	<a href="#">924</a>
C2803	<a href="#">912</a>	C2945	<a href="#">925</a>
C281	<a href="#">774</a>	C2946	<a href="#">925</a>
C2810	<a href="#">913</a>	C2959	<a href="#">925</a>
C2830	<a href="#">914</a>	C2960	<a href="#">925</a>
C2850	<a href="#">914</a>	C2962	<a href="#">925</a>
C2851	<a href="#">914</a>	C2963	<a href="#">926</a>
C2852	<a href="#">914</a>	C2964	<a href="#">926</a>
C2853	<a href="#">915</a>	C2965	<a href="#">926</a>
C2854	<a href="#">915</a>	C2996	<a href="#">926</a>
C2855	<a href="#">915</a>	C2997	<a href="#">926</a>
C2856	<a href="#">915</a>	C2998	<a href="#">926</a>
C2857	<a href="#">916</a>	C2999	<a href="#">926</a>
C2858	<a href="#">916</a>	C3	<a href="#">735</a>
C2859	<a href="#">916</a>	C308	<a href="#">775</a>
C2860	<a href="#">916</a>	C309	<a href="#">775</a>
C2861	<a href="#">916</a>	C310	<a href="#">775</a>
C2862	<a href="#">916</a>	C311	<a href="#">775</a>
C2863	<a href="#">917</a>	C312	<a href="#">776</a>
C2864	<a href="#">917</a>	C313	<a href="#">776</a>
C2865	<a href="#">917</a>	C314	<a href="#">777</a>
C2866	<a href="#">917</a>	C320	<a href="#">777</a>
C2867	<a href="#">917</a>	C321	<a href="#">778</a>
C2868	<a href="#">917</a>	C322	<a href="#">778</a>
C2869	<a href="#">917</a>	C323	<a href="#">779</a>

# Index

---

C324	<a href="#">779</a>	C398	<a href="#">796</a>
C325	<a href="#">779</a>	C399	<a href="#">796</a>
C326	<a href="#">779</a>	C4	<a href="#">744</a>
C327	<a href="#">779</a>	C412	<a href="#">796</a>
C328	<a href="#">780</a>	C413	<a href="#">797</a>
C329	<a href="#">780</a>	C414	<a href="#">797</a>
C330	<a href="#">780</a>	C415	<a href="#">797</a>
C335	<a href="#">780</a>	C416	<a href="#">797</a>
C336	<a href="#">780</a>	C417	<a href="#">797</a>
C337	<a href="#">780</a>	C418	<a href="#">798</a>
C338	<a href="#">780</a>	C420	<a href="#">798</a>
C34	<a href="#">746</a>	C421	<a href="#">798</a>
C343	<a href="#">780</a>	C422	<a href="#">798</a>
C344	<a href="#">781</a>	C423	<a href="#">798</a>
C345	<a href="#">781</a>	C424	<a href="#">799</a>
C346	<a href="#">781</a>	C427	<a href="#">799</a>
C347	<a href="#">782</a>	C435	<a href="#">799</a>
C348	<a href="#">782</a>	C436	<a href="#">800</a>
C349	<a href="#">782</a>	C437	<a href="#">800</a>
C350	<a href="#">783</a>	C443	<a href="#">801</a>
C351	<a href="#">783</a>	C444	<a href="#">801</a>
C352	<a href="#">783</a>	C462	<a href="#">802</a>
C356	<a href="#">784</a>	C464	<a href="#">802</a>
C357	<a href="#">784</a>	C465	<a href="#">802</a>
C359	<a href="#">784</a>	C466	<a href="#">802</a>
C360	<a href="#">785</a>	C467	<a href="#">802</a>
C361	<a href="#">785</a>	C468	<a href="#">803</a>
C367	<a href="#">786</a>	C469	<a href="#">803</a>
C368	<a href="#">786</a>	C490	<a href="#">803</a>
C369	<a href="#">786</a>	C494	<a href="#">803</a>
C372	<a href="#">787</a>	C495	<a href="#">803</a>
C373	<a href="#">788</a>	C497	<a href="#">804</a>
C374	<a href="#">789</a>	C5	<a href="#">744</a>
C375	<a href="#">789</a>	C50	<a href="#">747</a>
C376	<a href="#">790</a>	C51	<a href="#">747</a>
C377	<a href="#">790</a>	C512	<a href="#">804</a>
C378	<a href="#">790</a>	C513	<a href="#">804</a>
C379	<a href="#">791</a>	C514	<a href="#">804</a>
C381	<a href="#">791</a>	C515	<a href="#">804</a>
C382	<a href="#">791</a>	C516	<a href="#">804</a>
C383	<a href="#">791</a>	C52	<a href="#">747</a>
C385	<a href="#">792</a>	C53	<a href="#">747</a>
C386	<a href="#">792</a>	C54	<a href="#">747</a>
C387	<a href="#">793</a>	C55	<a href="#">748</a>
C388	<a href="#">793</a>	C56	<a href="#">748</a>
C390	<a href="#">793</a>	C569	<a href="#">805</a>
C391	<a href="#">794</a>	C57	<a href="#">748</a>
C392	<a href="#">795</a>	C570	<a href="#">805</a>
C393	<a href="#">795</a>	C571	<a href="#">805</a>
C394	<a href="#">795</a>	C572	<a href="#">806</a>
C395	<a href="#">795</a>	C573	<a href="#">806</a>
C396	<a href="#">795</a>	C574	<a href="#">806</a>
C397	<a href="#">796</a>	C576	<a href="#">806</a>

# Index

---

C577	<a href="#">807</a>	C646	<a href="#">820</a>
C578	<a href="#">807</a>	C647	<a href="#">820</a>
C579	<a href="#">807</a>	C648	<a href="#">821</a>
C58	<a href="#">748</a>	C649	<a href="#">821</a>
C580	<a href="#">807</a>	C65	<a href="#">750</a>
C581	<a href="#">808</a>	C650	<a href="#">821</a>
C582	<a href="#">808</a>	C651	<a href="#">821</a>
C583	<a href="#">808</a>	C658	<a href="#">821</a>
C584	<a href="#">808</a>	C659	<a href="#">822</a>
C585	<a href="#">809</a>	C66	<a href="#">750</a>
C586	<a href="#">809</a>	C68	<a href="#">750</a>
C587	<a href="#">809</a>	C69	<a href="#">750</a>
C588	<a href="#">810</a>	C691	<a href="#">822</a>
C589	<a href="#">810</a>	C692	<a href="#">822</a>
C59	<a href="#">749</a>	C693	<a href="#">822</a>
C591	<a href="#">810</a>	C694	<a href="#">822</a>
C594	<a href="#">811</a>	C695	<a href="#">822</a>
C595	<a href="#">811</a>	C696	<a href="#">822</a>
C596	<a href="#">811</a>	C697	<a href="#">823</a>
C597	<a href="#">812</a>	C698	<a href="#">823</a>
C598	<a href="#">812</a>	C7	<a href="#">745</a>
C599	<a href="#">812</a>	C70	<a href="#">750</a>
C6	<a href="#">745</a>	C71	<a href="#">750</a>
C60	<a href="#">749</a>	C72	<a href="#">751</a>
C600	<a href="#">813</a>	C730	<a href="#">823</a>
C601	<a href="#">813</a>	C731	<a href="#">823</a>
C604	<a href="#">813</a>	C732	<a href="#">823</a>
C606	<a href="#">813</a>	C733	<a href="#">823</a>
C607	<a href="#">814</a>	C734	<a href="#">823</a>
C61	<a href="#">749</a>	C735	<a href="#">823</a>
C610	<a href="#">814</a>	C736	<a href="#">824</a>
C611	<a href="#">814</a>	C737	<a href="#">824</a>
C612	<a href="#">815</a>	C738	<a href="#">824</a>
C613	<a href="#">815</a>	C739	<a href="#">824</a>
C614	<a href="#">816</a>	C74	<a href="#">751</a>
C615	<a href="#">816</a>	C75	<a href="#">751</a>
C618	<a href="#">816</a>	C76	<a href="#">751</a>
C619	<a href="#">817</a>	C77	<a href="#">751</a>
C62	<a href="#">749</a>	C770	<a href="#">824</a>
C620	<a href="#">817</a>	C771	<a href="#">824</a>
C621	<a href="#">817</a>	C772	<a href="#">825</a>
C625	<a href="#">818</a>	C773	<a href="#">825</a>
C63	<a href="#">749</a>	C774	<a href="#">825</a>
C635	<a href="#">818</a>	C775	<a href="#">825</a>
C636	<a href="#">818</a>	C776	<a href="#">825</a>
C637	<a href="#">818</a>	C777	<a href="#">826</a>
C64	<a href="#">749</a>	C778	<a href="#">826</a>
C640	<a href="#">819</a>	C779	<a href="#">826</a>
C641	<a href="#">819</a>	C78	<a href="#">751</a>
C642	<a href="#">819</a>	C780	<a href="#">826</a>
C643	<a href="#">819</a>	C781	<a href="#">826</a>
C644	<a href="#">820</a>	C782	<a href="#">827</a>
C645	<a href="#">820</a>	C783	<a href="#">827</a>

- C784 [827](#)
- C786 [827](#)
- C787 [827](#)
- C788 [828](#)
- C789 [828](#)
- C79 [752](#)
- C790 [828](#)
- C791 [828](#)
- C792 [828](#)
- C8 [745](#)
- C80 [752](#)
- C800 [829](#)
- C802 [829](#)
- C803 [829](#)
- C804 [829](#)
- C805 [829](#)
- C806 [830](#)
- C807 [830](#)
- C808 [830](#)
- C809 [830](#)
- C81 [752](#)
- C810 [830](#)
- C811 [831](#)
- C812 [831](#)
- C813 [831](#)
- C814 [831](#)
- C815 [831](#)
- C816 [832](#)
- C817 [832](#)
- C818 [832](#)
- C82 [752](#)
- C83 [752](#)
- C84 [752](#)
- C85 [753](#)
- C854 [832](#)
- C87 [753](#)
- C878 [832](#)
- C88 [753](#)
- C89 [753](#)
- C90 [753](#)
- C909 [833](#)
- C91 [753](#)
- C92 [754](#)
- C93 [754](#)
- C950 [833](#)
- C951 [833](#)
- C952 [834](#)
- C953 [834](#)
- C954 [835](#)
- C955 [835](#)
- C957 [835](#)
- C958 [836](#)
- C959 [836](#)
- C960 [836](#)
- C961 [836](#)
- C962 [836](#)
- C963 [837](#)
- C964 [837](#)
- C965 [837](#)
- C966 [837](#)
- C967 [837](#)
- C968 [838](#)
- C969 [838](#)
- C970 [838](#)
- C971 [838](#)
- C972 [838](#)
- C973 [839](#)
- C974 [839](#)
- C975 [839](#)
- C976 [839](#)
- C977 [839](#)
- C980 [840](#)
- C985 [840](#)
- C986 [840](#)
- C987 [840](#)
- C988 [840](#)
- C989 [841](#)
- C99 [754](#)
- C990 [841](#)
- C991 [841](#)
- C992 [841](#)
- C993 [842](#)
- C994 [842](#)
- C995 [842](#)
- C998 [842](#)
- Cam data
  - Invalid product number (error message) [723](#)
  - Invalidated due to change of mechanical data (error message) [722](#)
  - Serial number MM does not match (error message) [713](#)
- Cam data are corrupted (error message) [713](#)
- Cam data locked due to incorrect password (error message) [714](#)
- Cam data locked due to incorrect safety key (error message) [714](#)
- Cam data management [557](#)
- Cam Data Point Choice (C02923) [922](#)
- Cam data restored (error message) [713](#)
- Cam Track Choice (C02920) [921](#)
- Cam Track Type (C02921) [922](#)
- CamMemory (C02901) [919](#)
- CAN baud rate (C00351) [783](#)
- CAN baud rate setting [300](#)
- CAN behaviour in case of fault (C00625) [818](#)
- CAN bus load (C00361) [785](#)
- CAN delay boot-up - Operational (C00378) [790](#)
- CAN emergency delay time (C00392) [795](#)

- CAN Emergency Object (C00391) [794](#)
- CAN error (C00345) [781](#)
- CAN Error Register (DS301V402) (C00390) [793](#)
- CAN Guard Time (C00382) [791](#)
- CAN heartbeat activity (C00346) [781](#)
- CAN Heartbeat Consumer Time (C00385) [792](#)
- CAN Heartbeat producer time (C00381) [791](#)
- CAN heartbeat status (C00347) [782](#)
- CAN Life Time Factor (C00383) [791](#)
- CAN module (MXI1)
  - Basic configuration invalid (error message) [696](#)
  - Bus off (error message) [695](#)
  - Faulty emergency configuration (error message) [697](#)
  - Faulty NMT slave configuration (error message) [697](#)
  - Heartbeat error index 1 ... 32 (error message) [696](#)
  - Invalid node address 0 (error message) [695](#)
  - Lifeguarding error (error message) [696](#)
  - NMT master configuration faulty (error message) [698](#)
  - Node guarding error 1 ... 32 (error message) [697](#)
- CAN module (MXI1) PDO manager
  - Faulty configuration (error message) [700](#)
- CAN module (MXI1) RPDO1
  - Telegram not received or faulty (error message) [698](#)
- CAN module (MXI1) RPDO2
  - Telegram not received or faulty (error message) [698](#)
- CAN module (MXI1) RPDO3
  - Telegram not received or faulty (error message) [699](#)
- CAN module (MXI1) RPDO4
  - Telegram not received or faulty (error message) [699](#)
- CAN module (MXI1) RPDO5
  - Telegram not received or faulty (error message) [699](#)
- CAN module (MXI1) RPDO6
  - Telegram not received or faulty (error message) [699](#)
- CAN module (MXI1) RPDO7
  - Telegram not received or faulty (error message) [700](#)
- CAN module (MXI1) RPDO8
  - Telegram not received or faulty (error message) [700](#)
- CAN module (MXI1) SDO client
  - Faulty configuration (error message) [701](#)
- CAN module (MXI1) SDO server
  - Faulty configuration (error message) [700](#)
- CAN module (MXI2)
  - Basic configuration invalid (error message) [703](#)
  - Bus off (error message) [702](#)
  - Faulty emergency configuration (error message) [704](#)
  - Heartbeat error index 1 ... 32 (error message) [703](#)
  - Invalid node address 0 (error message) [703](#)
  - Lifeguarding error (error message) [704](#)
  - NMT master configuration faulty (error message) [705](#)
  - NMT slave configuration faulty (error message) [704](#)
  - Node guarding error 1 ... 32 (error message) [705](#)
- CAN module (MXI2) PDO manager
  - Faulty configuration (error message) [707](#)
- CAN module (MXI2) RPDO1
  - Telegram not received or faulty (error message) [705](#)
- CAN module (MXI2) RPDO2
  - Telegram not received or faulty (error message) [706](#)
- CAN module (MXI2) RPDO3
  - Telegram not received or faulty (error message) [706](#)
- CAN module (MXI2) RPDO4
  - Telegram not received or faulty (error message) [706](#)
- CAN module (MXI2) RPDO5
  - Telegram not received or faulty (error message) [706](#)
- CAN module (MXI2) RPDO6
  - Telegram not received or faulty (error message) [707](#)
- CAN module (MXI2) RPDO7
  - Telegram not received or faulty (error message) [707](#)
- CAN module (MXI2) RPDO8
  - Telegram not received or faulty (error message) [707](#)
- CAN module (MXI2) SDO client
  - Faulty configuration (error message) [708](#)
- CAN module (MXI2) SDO server
  - Faulty configuration (error message) [708](#)
- CAN node address (C00350) [783](#)
- CAN Node Guarding (C00386) [792](#)
- CAN Node Guarding Activity (C00387) [793](#)
- CAN node guarding status (C00388) [793](#)
- CAN on board [295](#)
  - Basic configuration invalid (error message) [676](#)
  - Bus off (error message) [676](#)
  - emergency configuration faulty (error message) [678](#)
  - Heartbeat error index 1 ... 32 (error message) [677](#)
  - Invalid node address 0 (error message) [676](#)
  - Lifeguarding guarding error (error message) [677](#)
  - NMT master configuration faulty (error message) [678](#)
  - NMT slave configuration faulty (error message) [677](#)
  - Node guarding error 1 ... 32 (error message) [678](#)
- CAN on board PDO manager
  - configuration faulty (error message) [680](#)
- CAN on board RPDO1
  - Telegram not received or faulty (error message) [679](#)
- CAN on board RPDO2
  - Telegram not received or faulty (error message) [679](#)
- CAN on board RPDO3
  - Telegram not received or faulty (error message) [679](#)
- CAN on board RPDO4
  - Telegram not received or faulty (error message) [679](#)
- CAN on board SDO client
  - configuration faulty (error message) [680](#)
- CAN on board SDO server
  - configuration faulty (error message) [680](#)
- CAN predefined error field (DS301V402) (C00394) [795](#)
- CAN result - bus scan (C00393) [795](#)
- CAN RPDO counter (C00344) [781](#)
- CAN RPDOx identifier (C00321) [778](#)
- CAN RPDOx monitoring time (C00357) [784](#)
- CAN RPDOx Rx mode (C00323) [779](#)
- CAN SDO client node address (C00374) [789](#)
- CAN SDO client Rx identifier (C00375) [789](#)
- CAN SDO client Tx identifier (C00376) [790](#)
- CAN SDO server node address (C00377) [790](#)

- CAN SDO server Rx identifier (C00372) [787](#)
  - CAN SDO server Tx identifier (C00373) [788](#)
  - CAN setting - DIP switch (C00349) [782](#)
  - CAN slave/master (C00352) [783](#)
  - CAN status (C00359) [784](#)
  - CAN status DIP switch (C00348) [782](#)
  - CAN SYNC application cycle (C01130) [846](#)
  - CAN SYNC Rx identifier (C00367) [786](#)
  - CAN sync transmission cycle time (C00369) [786](#)
  - CAN SYNC Tx identifier (C00368) [786](#)
  - CAN telegram and error counter (C00360) [785](#)
  - CAN TPDO counter (C00343) [780](#)
  - CAN TPDO1 mask byte x (C00311) [775](#)
  - CAN TPDO2 mask byte x (C00312) [776](#)
  - CAN TPDO3 mask byte x (C00313) [776](#)
  - CAN TPDO4 mask byte x (C00314) [777](#)
  - CAN TPDOx cycle time (C00356) [784](#)
  - CAN TPDOx delay time (C00324) [779](#)
  - CAN TPDOx identifier (C00320) [777](#)
  - CAN TPDOx Tx mode (C00322) [778](#)
  - CAN/EPL device type (C219) [771](#)
  - Capacitor temperature (C00068) [750](#)
  - Change Cam Data Point M (C02926) [923](#)
  - Change Cam Data Point X (C02924) [922](#)
  - Change Cam Data Point Y (C02925) [922](#)
  - Change of the basic function [385](#)
  - Change Pos Data Point X (C02964) [926](#)
  - Change Pos Data Point Y (C02965) [926](#)
  - Changing cam data via parameterisation [569](#)
  - Check configuration (C225) [771](#)
  - Clock [851](#), [852](#)
  - COB-ID [302](#)
  - COB-ID EMCY (I-1014) [350](#)
  - COB-ID SYNC message (I-1005) [346](#)
  - Code number duplicated (error message) [688](#)
  - Code refresh (error message) [643](#)
  - Combination memory module/device not possible (error message) [641](#)
  - Combination MXI1/MXI2 not possible (error message) [640](#)
  - Combination of module in MXI1/device not possible (error message) [642](#)
  - Combination of module in MXI2/device not possible (error message) [642](#)
  - Communication cycle period (I-1006) [347](#)
  - Communication error between device and device module (error message) [675](#)
  - Communication task
    - Standstill > 3 s (error message) [692](#)
  - Communication with module in MXI1 interrupted (error message) [675](#)
  - Communication with module in MXI2 interrupted (error message) [676](#)
  - Communication with safety module interrupted (error message) [693](#)
  - Config. analog input 1 (C00034) [746](#)
  - Configuration of system events [293](#)
  - ConnectTable active (error message) [686](#)
  - Consumer heartbeat time (I-1016) [351](#)
  - Cont Data Point Choice (C02943) [924](#)
  - Cont Pos X0 (C02944) [924](#)
  - Cont Pos X1 (C02945) [925](#)
  - Cont Time (C02946) [925](#)
  - Cont Track Choice (C02940) [923](#)
  - Cont Type (C02941) [924](#)
  - Control card
    - Supply voltage (24 V DC) too low (error message) [651](#)
    - Control card is defect (error message) [635](#), [637](#)
    - Control card is defect (UB18 neg.) (error message) [658](#)
    - Control card is defect (UB24) (error message) [657](#)
    - Control card is defect (UB8) (error message) [657](#)
    - Control card is defect (VCC15 neg.) (error message) [657](#)
    - Control card is defect (VCC15) (error message) [657](#)
    - Control card is defect (VCC5) (error message) [658](#)
    - Control card is incompatible (error message) [638](#)
  - Control mode (C02567) [869](#)
  - Control of two motor brakes [556](#)
  - Controlled operation (without feedback) [412](#)
  - Controller enabled (error message) [652](#)
  - Controller in STO state (error message) [652](#)
  - Controller inhibit by (source) (C00158) [761](#)
  - Correction of the leakage inductance [204](#)
  - CPU
    - Overtemperature (error message) [654](#)
    - Temperature > C00126 (error message) [654](#)
    - Thermal detector is defect (error message) [655](#)
  - CPU temp. warning threshold (C00126) [756](#)
  - CPU temperature (C00069) [750](#)
  - Curr. control par. of C75 C76 (C2866) [917](#)
  - Current (C02773) [906](#)
  - Current contr. reset time (C00076) [751](#)
  - Current controller gain (C00075) [751](#)
  - Current setpoint filter [153](#)
  - Cycle (C02536) [864](#)
  - Cyclic task
    - Standstill > 60 s (error message) [692](#)
- ## D
- D component position controller (C02555) [867](#)
  - Data type [725](#)
  - Date [851](#), [852](#)
  - DC brake
    - Activat. by quick stop (C00976) [839](#)
    - Current (C00974) [839](#)
    - Current for quick stop (C00975) [839](#)
  - DC bus overvoltage (error message) [661](#)
  - DC bus undervoltage (error message) [661](#)
  - DC-bus capacitor
    - Thermal detector is defect (error message) [655](#)
  - DC-bus voltage (C00053) [747](#)

DC-injection braking [215](#), [397](#)  
Decel. time - quick stop (C00105) [754](#)  
Decel. time lim. speed (C02712) [900](#)  
Deceleration has been limited (error message) [711](#)  
Deceleration time (C02775) [907](#)  
Deceleration time for stop (C02610) [879](#)  
Delay lim. speed (C02710) [900](#)  
Delay time for fan start (C01201) [849](#)  
Depth of current setpoint filter (C00272) [773](#)  
Device command status (C00003) [735](#)  
Device command transferred incorrectly (error message) [658](#)  
Device commands (C00002) [731](#)  
Device commands, commands  
  See device commands, C2 (device command), C3 (device command status) [45](#)  
Device name (C00199) [767](#)  
Device state (C00183) [766](#)  
Device states [100](#)  
Device type (I-1000) [344](#)  
Device utilisation (Ixt) (C00064) [749](#)  
Device utilisation Ixt > 100 % (error message) [656](#)  
Device utilisation Ixt > C00123 (error message) [656](#)  
DFIN (MXI1)  
  Signal error enable/lamp control (error message) [694](#)  
  Supply cannot be corrected anymore (error message) [695](#)  
  Track error A-/A (error message) [694](#)  
  Track error B-/B (error message) [694](#)  
  Track error Z-/Z (error message) [694](#)  
DFIN (MXI2)  
  Signal error enable/lamp control (error message) [702](#)  
  Supply cannot be corrected anymore (error message) [702](#)  
  Track error A-/A (error message) [701](#)  
  Track error B-/B (error message) [701](#)  
  Track error Z-/Z (error message) [701](#)  
DFOUT (MXI1)  
  Maximum frequency reached (error message) [695](#)  
DFOUT (MXI2)  
  Maximum frequency reached (error message) [702](#)  
DI\_bErrors (C02548) [866](#)  
DI\_dnState (C02547) [865](#)  
Diagnostics X6  
  Change baud rate (C01903) [857](#)  
  Curr. baud rate (C01905) [857](#)  
  Max. baud rate (C01902) [857](#)  
Dig. input x  
  Terminal polarity (C00114) [755](#)  
Dig. output x  
  Terminal polarity (C00118) [755](#)  
Digital inputs [282](#)  
  Delay time (C02830) [914](#)  
Digital outputs [284](#)  
DIP switches of the memory module [299](#)  
direct control [528](#)  
Disconnection in the case of par. storage (error message) [689](#)  
Distribution cam data memory [559](#)

Division by zero (error message) [648](#)  
Document history [14](#)  
Double motor [228](#), [556](#)  
Drive  
  Clamp operation (error message) [673](#)  
  Overload during acceleration phases (error message) [669](#)  
  Pulse inhibit is active (error message) [652](#)  
Drive interface [31](#)  
  Signals (C02549) [866](#)  
DRIVE-ERROR LED [101](#), [609](#)  
DRIVE-READY LED [101](#), [609](#)  
Dual motor temperature (C01200) [849](#)  
Dynamic of resolver evaluation (C00417) [797](#)  
Dynamics of the actual value detection [152](#)

## E

Earth fault detected (error message) [662](#)  
Elapsed-hour meter (C00178) [765](#)  
Electronic cam [557](#)  
Electronic nameplate  
  Checksum error (error message) [641](#)  
  Communication error (error message) [641](#)  
  Data are incompatible (error message) [658](#)  
  Data loaded (error message) [668](#)  
  Data outside the parameter limits (error message) [670](#)  
  Encoder protocol unknown (error message) [668](#)  
  Encoder signal unknown (error message) [668](#)  
  Not found (error message) [668](#)  
Electronic nameplate status (C2858) [916](#)  
E-mail to Lenze [967](#)  
Emergency telegram [341](#)  
EN 60204-1 [369](#)  
EN 954 [369](#)  
ENC\_bError (C02765) [905](#)  
Encoder  
  Open circuit (error message) [664](#)  
Encoder - angular drift monitoring [267](#)  
Encoder evaluation [239](#)  
  Dig. signals (C02579) [872](#)  
Encoder monitoring  
  Pulse deviation detected (error message) [671](#)  
Encoder position (C02762) [904](#)  
Encoder revolution (C02763) [904](#)  
Encoder signal X8 [263](#)  
Encoder type (C00422) [798](#)  
Encoder voltage (C00421) [798](#)  
Encoderspeed (C02764) [904](#)  
EnDat encoder  
  Battery empty (error message) [667](#)  
  Command error (error message) [674](#)  
  Lamp error (error message) [666](#)  
  Overcurrent (error message) [667](#)  
  Overvoltage (error message) [666](#)  
  Position error (error message) [666](#)  
  Position initialisation error (error message) [674](#)



# Index

---

Signal error (error message) <a href="#">666</a>	0x0068001c <a href="#">641</a>
Transmission error (error message) <a href="#">673</a>	0x0068001d <a href="#">641</a>
Undervoltage (error message) <a href="#">667</a>	0x0068001e <a href="#">641</a>
Energy	0x0068001f <a href="#">641</a>
Comp. to be switched off (C01704) <a href="#">856</a>	0x00680020 <a href="#">642</a>
Mode inform. (C01700) <a href="#">855</a>	0x00680021 <a href="#">642</a>
Power input (C01705) <a href="#">857</a>	0x00680022 <a href="#">642</a>
toff (C01702) <a href="#">855</a>	0x00680023 <a href="#">642</a>
toff min (C01701) <a href="#">855</a>	0x00680024 <a href="#">643</a>
ton (C01703) <a href="#">855</a>	0x00690000 <a href="#">643</a>
Enhanced Power (C01199) <a href="#">849</a>	0x00690001 <a href="#">643</a>
ENP	0x00690002 <a href="#">643</a>
Identified motor type (C00186) <a href="#">767</a>	0x00690003 <a href="#">644</a>
Identified serial number (C00187) <a href="#">767</a>	0x00690004 <a href="#">644</a>
Status (C00188) <a href="#">767</a>	0x00690005 <a href="#">644</a>
Error	0x00690006 <a href="#">644</a>
Lenze Setting Loaded (error message) <a href="#">687</a>	0x00690007 <a href="#">644</a>
Error behaviour (I-1029) <a href="#">352</a>	0x00690008 <a href="#">645</a>
Error description (C00166) <a href="#">762</a>	0x00690009 <a href="#">645</a>
Error during initialisation (error message) <a href="#">693</a>	0x0069000a <a href="#">645</a>
Error message "Unknown error" <a href="#">626</a> , <a href="#">634</a>	0x0069000b <a href="#">645</a>
Error messages <a href="#">620</a>	0x0069000c <a href="#">645</a>
Error messages (short overview) <a href="#">626</a>	0x0069000d <a href="#">646</a>
Error messages (system bus) <a href="#">322</a>	0x006a0000 <a href="#">646</a>
Error number <a href="#">620</a>	0x006a0001 <a href="#">646</a>
0x00650000 <a href="#">634</a>	0x006a0002 <a href="#">646</a>
0x00650001 <a href="#">634</a>	0x006a0003 <a href="#">647</a>
0x00650002 <a href="#">634</a>	0x006a0004 <a href="#">647</a>
0x00650003 <a href="#">635</a>	0x006a0005 <a href="#">647</a>
0x00680000 <a href="#">635</a>	0x006a0006 <a href="#">647</a>
0x00680001 <a href="#">635</a>	0x006a000d <a href="#">648</a>
0x00680002 <a href="#">635</a>	0x006a000e <a href="#">648</a>
0x00680003 <a href="#">636</a>	0x006a000f <a href="#">648</a>
0x00680004 <a href="#">636</a>	0x006a0010 <a href="#">648</a>
0x00680005 <a href="#">636</a>	0x006a0011 <a href="#">648</a>
0x00680006 <a href="#">636</a>	0x006a0012 <a href="#">649</a>
0x00680007 <a href="#">637</a>	0x006a0013 <a href="#">649</a>
0x00680008 <a href="#">637</a>	0x006a0014 <a href="#">649</a>
0x00680009 <a href="#">637</a>	0x006a0015 <a href="#">649</a>
0x0068000a <a href="#">637</a>	0x006a0016 <a href="#">650</a>
0x0068000b <a href="#">637</a>	0x006a0017 <a href="#">650</a>
0x0068000c <a href="#">638</a>	0x006a001a <a href="#">650</a>
0x0068000d <a href="#">638</a>	0x006a001b <a href="#">651</a>
0x0068000e <a href="#">638</a>	0x006f0000 <a href="#">651</a>
0x0068000f <a href="#">638</a>	0x00720000 <a href="#">651</a>
0x00680010 <a href="#">638</a>	0x00750000 <a href="#">651</a>
0x00680011 <a href="#">639</a>	0x00750001 <a href="#">652</a>
0x00680012 <a href="#">639</a>	0x00750003 <a href="#">652</a>
0x00680013 <a href="#">639</a>	0x00750005 <a href="#">652</a>
0x00680014 <a href="#">639</a>	0x00750006 <a href="#">652</a>
0x00680015 <a href="#">639</a>	0x00770000 <a href="#">652</a>
0x00680016 <a href="#">640</a>	0x00770001 <a href="#">653</a>
0x00680017 <a href="#">640</a>	0x00770002 <a href="#">653</a>
0x00680018 <a href="#">640</a>	0x00770003 <a href="#">653</a>
0x00680019 <a href="#">640</a>	0x00770008 <a href="#">654</a>
0x0068001a <a href="#">640</a>	0x00770009 <a href="#">654</a>
0x0068001b <a href="#">641</a>	0x0077000a <a href="#">654</a>
	0x0077000b <a href="#">654</a>

# Index

---

0x0077000c	<a href="#">655</a>	0x007b002c	<a href="#">667</a>
0x0077000d	<a href="#">655</a>	0x007b002d	<a href="#">667</a>
0x0077000e	<a href="#">655</a>	0x007b002e	<a href="#">667</a>
0x0077000f	<a href="#">655</a>	0x007b002f	<a href="#">668</a>
0x00770010	<a href="#">656</a>	0x007b0030	<a href="#">668</a>
0x00770011	<a href="#">656</a>	0x007b0031	<a href="#">668</a>
0x00780000	<a href="#">656</a>	0x007b0032	<a href="#">668</a>
0x00780001	<a href="#">656</a>	0x007b0033	<a href="#">668</a>
0x00780002	<a href="#">656</a>	0x007b0034	<a href="#">669</a>
0x00780003	<a href="#">657</a>	0x007b0035	<a href="#">669</a>
0x00780004	<a href="#">657</a>	0x007b0036	<a href="#">669</a>
0x00780005	<a href="#">657</a>	0x007b0037	<a href="#">669</a>
0x00780006	<a href="#">657</a>	0x007b0038	<a href="#">669</a>
0x00780007	<a href="#">657</a>	0x007b0039	<a href="#">670</a>
0x00780008	<a href="#">658</a>	0x007b003a	<a href="#">670</a>
0x00780009	<a href="#">658</a>	0x007b003b	<a href="#">670</a>
0x0078000a	<a href="#">658</a>	0x007b003c	<a href="#">671</a>
0x00790000	<a href="#">658</a>	0x007b003d	<a href="#">671</a>
0x00790001	<a href="#">658</a>	0x007b003e	<a href="#">671</a>
0x00790002	<a href="#">659</a>	0x007b003f	<a href="#">672</a>
0x007b0001	<a href="#">659</a>	0x007b0040	<a href="#">672</a>
0x007b0002	<a href="#">659</a>	0x007b0041	<a href="#">672</a>
0x007b0003	<a href="#">659</a>	0x007b0042	<a href="#">672</a>
0x007b0004	<a href="#">659</a>	0x007b0047	<a href="#">673</a>
0x007b0006	<a href="#">660</a>	0x007b004a	<a href="#">673</a>
0x007b0007	<a href="#">660</a>	0x007b004c	<a href="#">673</a>
0x007b0009	<a href="#">660</a>	0x007b004e	<a href="#">673</a>
0x007b000a	<a href="#">660</a>	0x007b004f	<a href="#">674</a>
0x007b000b	<a href="#">660</a>	0x007b0050	<a href="#">674</a>
0x007b000c	<a href="#">661</a>	0x007c0000	<a href="#">674</a>
0x007b000d	<a href="#">661</a>	0x007c0001	<a href="#">674</a>
0x007b000e	<a href="#">661</a>	0x007d0000	<a href="#">675</a>
0x007b000f	<a href="#">661</a>	0x007d0001	<a href="#">675</a>
0x007b0010	<a href="#">661</a>	0x007f0002	<a href="#">675</a>
0x007b0011	<a href="#">662</a>	0x007f0003	<a href="#">675</a>
0x007b0012	<a href="#">662</a>	0x007f0004	<a href="#">676</a>
0x007b0013	<a href="#">662</a>	0x00830000	<a href="#">676</a>
0x007b0014	<a href="#">662</a>	0x00830001	<a href="#">676</a>
0x007b0017	<a href="#">662</a>	0x00830002	<a href="#">676</a>
0x007b0018	<a href="#">663</a>	0x00840000	<a href="#">677</a>
0x007b0019	<a href="#">663</a>	0x00840020	<a href="#">677</a>
0x007b001a	<a href="#">663</a>	0x00840021	<a href="#">677</a>
0x007b001b	<a href="#">664</a>	0x00850000	<a href="#">678</a>
0x007b001c	<a href="#">664</a>	0x00860000	<a href="#">678</a>
0x007b001d	<a href="#">664</a>	0x00860020	<a href="#">678</a>
0x007b001e	<a href="#">664</a>	0x00870000	<a href="#">679</a>
0x007b001f	<a href="#">665</a>	0x00870001	<a href="#">679</a>
0x007b0020	<a href="#">665</a>	0x00870002	<a href="#">679</a>
0x007b0021	<a href="#">665</a>	0x00870003	<a href="#">679</a>
0x007b0023	<a href="#">665</a>	0x00870008	<a href="#">680</a>
0x007b0024	<a href="#">665</a>	0x00880000	<a href="#">680</a>
0x007b0025	<a href="#">666</a>	0x00890000	<a href="#">680</a>
0x007b0026	<a href="#">666</a>	0x008c0000	<a href="#">680</a>
0x007b0027	<a href="#">666</a>	0x008c0001	<a href="#">681</a>
0x007b0028	<a href="#">666</a>	0x008c0002	<a href="#">681</a>
0x007b0029	<a href="#">666</a>	0x008c0003	<a href="#">681</a>
0x007b002a	<a href="#">667</a>	0x008c0004	<a href="#">681</a>
0x007b002b	<a href="#">667</a>	0x008c0005	<a href="#">681</a>

# Index

---

0x008c0006	<a href="#">682</a>	0x00990003	<a href="#">694</a>
0x008c0007	<a href="#">682</a>	0x00990004	<a href="#">695</a>
0x008c0008	<a href="#">682</a>	0x00990005	<a href="#">695</a>
0x008c0009	<a href="#">682</a>	0x009d0000	<a href="#">695</a>
0x008c000a	<a href="#">682</a>	0x009d0001	<a href="#">695</a>
0x008c000b	<a href="#">683</a>	0x009d0002	<a href="#">696</a>
0x008c000c	<a href="#">683</a>	0x009e0000	<a href="#">696</a>
0x008c000d	<a href="#">683</a>	0x009e0020	<a href="#">696</a>
0x008c000e	<a href="#">683</a>	0x009e0021	<a href="#">697</a>
0x008c000f	<a href="#">684</a>	0x009f0000	<a href="#">697</a>
0x008c0010	<a href="#">684</a>	0x00a00000	<a href="#">697</a>
0x008c0011	<a href="#">684</a>	0x00a00020	<a href="#">698</a>
0x008c0012	<a href="#">684</a>	0x00a10000	<a href="#">698</a>
0x008c0013	<a href="#">684</a>	0x00a10001	<a href="#">698</a>
0x008c0014	<a href="#">685</a>	0x00a10002	<a href="#">699</a>
0x008c0015	<a href="#">685</a>	0x00a10003	<a href="#">699</a>
0x008c0016	<a href="#">685</a>	0x00a10004	<a href="#">699</a>
0x008c0017	<a href="#">685</a>	0x00a10005	<a href="#">699</a>
0x008c0018	<a href="#">685</a>	0x00a10006	<a href="#">700</a>
0x008c001a	<a href="#">686</a>	0x00a10007	<a href="#">700</a>
0x008c001d	<a href="#">686</a>	0x00a10008	<a href="#">700</a>
0x008c001e	<a href="#">686</a>	0x00a20000	<a href="#">700</a>
0x00900000	<a href="#">686</a>	0x00a30000	<a href="#">701</a>
0x00900001	<a href="#">687</a>	0x00aa0000	<a href="#">701</a>
0x00900002	<a href="#">687</a>	0x00aa0001	<a href="#">701</a>
0x00900003	<a href="#">687</a>	0x00aa0002	<a href="#">701</a>
0x00900004	<a href="#">687</a>	0x00aa0003	<a href="#">702</a>
0x00900005	<a href="#">687</a>	0x00aa0004	<a href="#">702</a>
0x00900006	<a href="#">688</a>	0x00aa0005	<a href="#">702</a>
0x00900007	<a href="#">688</a>	0x00ac0000	<a href="#">702</a>
0x00900008	<a href="#">688</a>	0x00ac0001	<a href="#">703</a>
0x00900009	<a href="#">688</a>	0x00ac0002	<a href="#">703</a>
0x0090000a	<a href="#">689</a>	0x00ad0000	<a href="#">703</a>
0x0090000b	<a href="#">689</a>	0x00ad0020	<a href="#">704</a>
0x0090000c	<a href="#">689</a>	0x00ad0021	<a href="#">704</a>
0x00910000	<a href="#">689</a>	0x00ae0000	<a href="#">704</a>
0x00910001	<a href="#">690</a>	0x00af0000	<a href="#">705</a>
0x00910002	<a href="#">690</a>	0x00af0020	<a href="#">705</a>
0x00910003	<a href="#">690</a>	0x00b00000	<a href="#">705</a>
0x00910004	<a href="#">690</a>	0x00b00001	<a href="#">706</a>
0x00910005	<a href="#">690</a>	0x00b00002	<a href="#">706</a>
0x00910006	<a href="#">691</a>	0x00b00003	<a href="#">706</a>
0x00910008	<a href="#">691</a>	0x00b00004	<a href="#">706</a>
0x00910009	<a href="#">691</a>	0x00b00005	<a href="#">707</a>
0x0091000a	<a href="#">691</a>	0x00b00006	<a href="#">707</a>
0x0091000b	<a href="#">691</a>	0x00b00007	<a href="#">707</a>
0x0091000c	<a href="#">692</a>	0x00b00008	<a href="#">707</a>
0x0091000d	<a href="#">692</a>	0x00b10000	<a href="#">708</a>
0x0091000e	<a href="#">692</a>	0x00b20000	<a href="#">708</a>
0x0091000f	<a href="#">692</a>	0x00b80000	<a href="#">708</a>
0x00910010	<a href="#">693</a>	0x00b80001	<a href="#">708</a>
0x00910011	<a href="#">693</a>	0x00b80002	<a href="#">709</a>
0x00910012	<a href="#">693</a>	0x00b80003	<a href="#">709</a>
0x00920000	<a href="#">693</a>	0x00b80004	<a href="#">709</a>
0x00920001	<a href="#">693</a>	0x00b80005	<a href="#">710</a>
0x00990000	<a href="#">694</a>	0x00b80007	<a href="#">710</a>
0x00990001	<a href="#">694</a>	0x00b80008	<a href="#">710</a>
0x00990002	<a href="#">694</a>	0x00b80009	<a href="#">710</a>

- 0x00b8000a [711](#)
- 0x00b8000b [711](#)
- 0x00b8000c [711](#)
- 0x00b8000d [711](#)
- 0x00b8000e [712](#)
- 0x00b8000f [712](#)
- 0x00b80010 [712](#)
- 0x00b80011 [712](#)
- 0x00b80012 [713](#)
- 0x00b80013 [713](#)
- 0x00b80014 [713](#)
- 0x00b80015 [713](#)
- 0x00b80016 [714](#)
- 0x00b80017 [714](#)
- 0x00b80019 [714](#)
- 0x00b8001a [714](#)
- 0x00b8001b [715](#)
- 0x00b8001c [715](#)
- 0x00b8001d [715](#)
- 0x00b80020 [716](#)
- 0x00b80021 [716](#)
- 0x00b80022 [716](#)
- 0x00b80023 [717](#)
- 0x00b80024 [717](#)
- 0x00b80025 [717](#)
- 0x00b80026 [718](#)
- 0x00b80027 [718](#)
- 0x00b80028 [718](#)
- 0x00b80029 [719](#)
- 0x00b8002a [719](#)
- 0x00b8002b [719](#)
- 0x00b8002c [720](#)
- 0x00b8002d [720](#)
- 0x00b8002e [720](#)
- 0x00b8002f [721](#)
- 0x00b80030 [721](#)
- 0x00b80031 [721](#)
- 0x00b80032 [722](#)
- 0x00b80033 [722](#)
- 0x00b80034 [722](#)
- 0x00b80035 [723](#)
- Error number (C00168) [763](#)
- Error register (I-1001) [344](#)
- Ethernet IP address client x (C01510) [854](#)
- Ethernet status client x (C01511) [854](#)
- Exception response [109](#)
- Exporting logbook entries [616](#)
- Ext. 24-V voltage (C00065) [750](#)
- External actual position (C02577) [872](#)
- External error (error message) [651](#)
- F**
- Failure of a mains phase (error message) [672](#)
- Failure of motor phase U (error message) [667](#)
- Failure of motor phase V (error message) [667](#)
- Failure of motor phase W (error message) [668](#)
- Fan control status (C00587) [809](#)
- Fault during the update of inputs and outputs (error message) [646](#)
- Fault in the control configuration (error message) [650](#)
- Faulty application parameter (error message) [648](#)
- Faulty program download (error message) [646](#)
- Feed constant (C02524) [861](#)
- Feedback [35](#)
- Feedback to Lenze [967](#)
- Feedforward control of torque [157](#)
- Feedfwd. ctrl. - current contr. (C00074) [751](#)
- Field contr. reset time (C00078) [751](#)
- Field controller gain (C00077) [751](#)
- Field weak. contr. reset time (C00578) [807](#)
- Field weakening controller gain (C00577) [807](#)
- Field weakening for SM (C00093) [754](#)
- Field weakening for synchronous machines [209](#)
- File DeviceCFG.dat defect (error message) [681](#)
- File DeviceCFG.dat invalid (error message) [682](#)
- File DeviceCFG.dat is missing (error message) [681](#)
- File ProjectList.dat defect (error message) [681](#)
- File ProjectList.dat invalid (error message) [682](#)
- File ProjectList.dat is missing (error message) [681](#)
- File ProjectSelection.dat defect (error message) [680](#)
- File ProjectSelection.dat invalid (error message) [682](#)
- File ProjectSelection.dat is missing (error message) [681](#)
- Filter for PWM adjustment (C00281) [774](#)
- Filter time const. DC detection (C00280) [774](#)
- Filter time constant (C02562) [869](#)
- Filtered torque setpoint (C00697) [823](#)
- Firmware - compiling date (C00201) [768](#)
- Firmware has been changed (error message) [640](#)
- Firmware is incompatible with control card (error message) [641](#)
- Firmware product type (C00200) [767](#)
- Firmware version (C00099) [754](#)
- Flying restart circuit
  - Activation (C00990) [841](#)
  - Current (C00991) [841](#)
  - Delay time (C00995) [842](#)
  - Integration time (C00993) [842](#)
  - Min. deviation (C00994) [842](#)
  - Start frequency (C00992) [841](#)
- Flying restart function [212](#)
- Following error (C02576) [872](#)
- Freq. - current setpoint filter (C00270) [772](#)
- Frequency (C02771) [905](#)
- G**
- GDO channel 1/trigger 1 (C731) [823](#)
- GDO channel 2/trigger 2 (C732) [823](#)
- GDO channel 3 (C733) [823](#)
- GDO channel 4 (C734) [823](#)
- GDO channel 5 (C735) [823](#)
- GDO channel 6 (C736) [824](#)

# Index

---

GDO channel 7 (C737) [824](#)  
GDO channel 8 (C738) [824](#)  
GDO general parameters (C730) [823](#)  
GDO status information (C739) [824](#)  
Gearbox fac. denom.  
  Pos. enc. (C02523) [861](#)  
Gearbox factor denominator  
  Motor (C02521) [860](#)  
Gearbox factor num.  
  Pos. enc. (C02522) [860](#)  
Gearbox factor numerator  
  Motor (C02520) [860](#)  
Gearbox factors (decimal) (C02531) [863](#)  
General error in the application (error message) [646](#)  
gotolink parameter.fm  
  c2702 [520](#)  
Grinding OFF time (C02599) [876](#)  
Grinding ON time (C02598) [876](#)  
Grinding speed (C02596) [876](#)  
Guard time [333](#)  
Guard time (I-100C) [347](#)  
GUID (C02903) [919](#)

## H

Hardware limit positions [515](#)  
Heartbeat not periodic (error message) [690](#)  
Heartbeat protocol [337](#)  
Heatsink  
  Fan is defect (error message) [656](#)  
  Overtemperature (error message) [653](#)  
  Temperature > C00122 (error message) [652](#)  
  Thermal detector is defect (error message) [654](#)  
Heatsink temp. warn. threshold (C00122) [756](#)  
Heatsink temperature (C00061) [749](#)  
Hiperface  
  detected TypeCode (C00413) [797](#)  
  Initialisation time (C00412) [796](#)  
  number of rev. (C00415) [797](#)  
  TypeCode (C00414) [797](#)  
Hiperface encoder  
  Command error (error message) [670](#)  
  Position initialisation error (error message) [671](#)  
  Transmission error (error message) [670](#)  
  Unknown encoder (error message) [671](#)  
HM\_dnHomePos\_p (C02658) [891](#)  
HM\_dnSpeedOverride\_n (C02655) [890](#)  
HM\_dnState (C02657) [891](#)  
Holding brake [521](#)  
Home position (C02642) [888](#)  
Homing [421](#)  
  Acceleration 1 (C02645) [888](#)  
  Acceleration 2 (C02647) [889](#)  
  Blocking time (C02650) [889](#)  
  Dig. signals (C02659) [891](#)  
  Speed 1 (C02644) [888](#)

  Speed 2 (C02646) [889](#)  
  S-ramp time (C02648) [889](#)  
  Target position (C02643) [888](#)  
  Torque limit (C02649) [889](#)  
  TP configuration (C02651) [890](#)  
Homing mode (C02640) [886](#)  
Homing mode not allowed (error message) [714](#)  
HW countries of origin (C00209) [770](#)  
HW descriptions (C00205) [769](#)  
HW manufacturer (C00208) [769](#)  
HW manufacturing data (C00206) [769](#)  
HW product types (C00203) [768](#)  
HW serial numbers (C00204) [768](#)  
HW versions (C00210) [770](#)  
Hysteresis for POS\_bDriveInTarget (C02672) [892](#)

## I

I-1000 [344](#)  
I-1001 [344](#)  
I-1003 [345](#)  
I-1005 [346](#)  
I-1006 [347](#)  
I-100C [347](#)  
I-100D [347](#)  
I-1010 [348](#)  
I-1011 [349](#)  
I-1014 [350](#)  
I-1015 [350](#)  
I-1016 [351](#)  
I-1017 [351](#)  
I-1018 [352](#)  
I-1029 [352](#)  
I-1200 [353](#)  
I-1201 [354](#)  
I-1202 [356](#)  
I-1203 [356](#)  
I-1204 [356](#)  
I-1205 [356](#)  
I-1206 [357](#)  
I-1207 [357](#)  
I-1208 [357](#)  
I-1209 [357](#)  
I-1400 [358](#)  
I-1401 [359](#)  
I-1402 [359](#)  
I-1403 [360](#)  
I-1600 [360](#)  
I-1601 [361](#)  
I-1602 [361](#)  
I-1603 [361](#)  
I-1800 [362](#)  
I-1801 [363](#)  
I-1802 [364](#)  
I-1803 [364](#)

I-1A00 [365](#)  
I-1A01 [365](#)  
I-1A02 [366](#)  
I-1A03 [366](#)  
ID status (C00854) [832](#)  
Identifier (CAN) [302](#)  
Identity object (I-1018) [352](#)  
IdleTask  
    Overflow (error message) [647](#)  
IEC 61508 [369](#)  
Imax Lss saturation characteristic (C02855) [915](#)  
Inching mode [400](#)  
Incorrect memory module (error message) [639](#)  
Incorrect safety module (error message) [639](#)  
Increased continuous power [112](#)  
Influence winding I<sup>2</sup>t mon. (C01195) [848](#)  
Information regarding the validity [13](#)  
Inhibit time EMCY (I-1015) [350](#)  
Inside the device  
    Fan is defect (error message) [656](#)  
    Thermal detector is defective (error message) [654](#)  
Instant of PDO acceptance [316](#)  
Instant of PDO transmission [316](#)  
Int. overflow C02620 (manual jog  
    Speed 1) (error message) [714](#)  
Int. overflow C02621 (manual jog  
    Speed 2) (error message) [715](#)  
Int. overflow C02622 (manual jog  
    acceleration) (error message) [715](#)  
Int. overflow C02623 (manual jog  
    deceleration) (error message) [715](#)  
Int. overflow C02642 (home position) (error message) [720](#)  
Int. overflow C02643 (homing  
    Target position) (error message) [720](#)  
Int. overflow C02644 (homing  
    Speed 1) (error message) [721](#)  
Int. overflow C02645 (homing  
    Acceleration 1) (error message) [721](#)  
Int. overflow C02646 (homing  
    Speed 2) (error message) [721](#)  
Int. overflow C02647 (homing  
    Acceleration 2) (error message) [722](#)  
Int. overflow C02670 (positioner  
    Tol. for target position) (error message) [722](#)  
Int. overflow C02701/1 (positive software limit position) (error  
message) [716](#)  
Int. overflow C02701/2 (negative software limit position) (error  
message) [716](#)  
Int. overflow C02703 (maximum speed) (error message) [716](#)  
Int. overflow C02705 (maximum acceleration) (error message)  
[717](#)  
Int. overflow C02708/1 (decel. limited speed 1) (error message)  
[718](#)  
Int. overflow C02708/1 (limited speed 1) (error message) [717](#)  
Int. overflow C02708/2 (decel. limited speed 2) (error message)

[719](#)  
Int. overflow C02708/2 (limited speed 2) (error message) [717](#)  
Int. overflow C02708/3 (decel. limited speed 3) (error message)  
[719](#)  
Int. overflow C02708/3 (limited speed 3) (error message) [718](#)  
Int. overflow C02708/4 (decel. limited speed 4) (error message)  
[719](#)  
Int. overflow C02708/4 (limited speed 4) (error message) [718](#)  
Int. overflow C02713 (max. dist. manual control) (error  
message) [720](#)  
Integrated safety system [369](#)  
Internal clock (C01214) [851](#)  
Internal communication error (DMA) (error message) [669](#)  
Internal communication error (host MCTRL) (error message)  
[662](#)  
Internal communication error (MCTRL host) (error message)  
[669](#)  
Internal error  
    See C00180 (error message) [690](#), [691](#)  
Internal error (CRC application) (error message) [686](#)  
Internal error (event mechanism) (error message) [645](#)  
Internal error (file system lifetime) (error message) [646](#)  
Internal error (LDS instance data) (error message) [643](#)  
Internal error (LDS tasks) (error message) [644](#)  
Internal error (memory area - logbook) (error message) [643](#)  
Internal error (message memory) (error message) [644](#)  
Internal error (message queue) (error message) [644](#)  
Internal error (name data base) (error message) [645](#)  
Internal error (semaphores) (error message) [645](#)  
Internal error (storage blocks) (error message) [644](#)  
Internal error (task queue) (error message) [644](#)  
Internal torque limits (C02559) [868](#)

## J

Jerk [385](#), [387](#)  
Jerk has been limited (error message) [712](#)

## K

Keypad  
    Default parameter (C00466) [802](#)  
    Default welcome screen (C00467) [802](#)  
    Fct. STOP key (C00469) [803](#)  
    Mode (C00464) [802](#)  
    Timeout welcome screen (C00465) [802](#)  
Keypad LCD display [611](#)

## L

Layout of the safety instructions [17](#)  
LCD display (keypad) [611](#)  
LED status display [608](#)  
LED status displays for the system bus [301](#)  
Lh adjustment (C02861) [916](#)  
Life guarding event [334](#)  
Life time factor (I-100D) [347](#)  
LIM\_dnState (C02718) [902](#)

- LIM\_dwControl (C02717) [901](#)
- Limit positions [512](#), [515](#)
  - Triggering behaviour [514](#)
- Limit switch [515](#)
- Limitation active (C02715) [901](#)
- Limitations effective (C02702) [898](#)
- Limited speed (C02708) [899](#)
- Limited speed [rpm] (C02709) [899](#)
- Limiter [370](#), [506](#)
  - Dig. signals (C02719) [902](#)
- Load reference speed (C02542) [865](#)
- Load reference torque (C02543) [865](#)
- Loading of Lenze setting failed (error message) [687](#)
- Logbook [613](#)
  - Overflow (error message) [634](#)
  - Reset (read error) (error message) [634](#)
  - Reset (version error) (error message) [634](#)
- Logbook - event filter (C00169) [763](#)
- LS\_AnalogInput [279](#)
- LS\_AnalogOutput [281](#)
- LS\_Brake [523](#)
- LS\_CamInterface [563](#)
- LS\_DigitalInput [283](#)
- LS\_DigitalOutput [285](#)
- LS\_DriveInterface [113](#)
- LS\_EncoderX8 [263](#)
- LS\_Feedback [240](#)
- LS\_Homing [423](#)
- LS\_Limiter [506](#)
- LS\_ManualJog [401](#)
- LS\_ManualJogOpenLoop [419](#)
- LS\_MotorInterface [234](#)
- LS\_PolePositionIdentification [576](#)
- LS\_Positioner [480](#)
- LS\_PositionFollower [491](#)
- LS\_quick stop [393](#)
- LS\_SafetyModuleInterface [371](#)
- LS\_SpeedFollower [496](#)
- LS\_SsiEncoderX8 [256](#)
- LS\_Stop [390](#)
- LS\_SyncInput [367](#)
- LS\_TorqueFollower [502](#)
- LS\_TouchProbe1 [291](#)
- LS\_TouchProbe2 [291](#)
- LS\_TouchProbe3 [291](#)
- LS\_TouchProbe4 [291](#)
- LS\_TouchProbe5 [291](#)
- LS\_TouchProbe6 [291](#)
- LS\_TouchProbe7 [291](#)
- LS\_TouchProbe8 [291](#)
- LS\_TouchProbeLoad [292](#)
- LS\_TouchProbeMotor [292](#)
- Lss sat. characteristic (C02853) [915](#)
- M**
- Machine parameters [32](#)
- Mains connection [107](#)
- Mains recov. detect. threshold (C00185) [767](#)
- Mains voltage (C00173) [764](#)
- Mains voltage is switched off (error message) [690](#)
- Mains voltage is switched on (error message) [689](#)
- MAN\_dnSpeedOverride\_n (C02637) [882](#)
- Manual jog [400](#)
  - Acceleration (C02622) [881](#)
  - Deceleration (C02623) [881](#)
  - Dig. signals (C02639) [883](#)
  - Index Stop position (C02626) [882](#)
  - Selected Stop position (C02627) [882](#)
  - Speed 1 (C02620) [880](#)
  - Speed 2 (C02621) [881](#)
  - S-ramp time (C02624) [881](#)
  - Status (C02638) [883](#)
  - Step size (C02625) [881](#)
- Manual jog to software limit position [410](#)
- Manual jog, encoderless [412](#)
- ManualJogOpenLoop
  - Dig. signals (C02781) [908](#)
- Masked Error number (C00162) [762](#)
- Master functionality (CAN) [308](#)
- Max. acceleration (C02705) [898](#)
- Max. acceleration change (C00274) [773](#)
- Max. dist. manual control (C02713) [900](#)
- Max. dist. manual jog [Incr.] (C02714) [901](#)
- Max. presentable acceleration (C02541) [864](#)
- Max. presentable position (C02539) [864](#)
- Max. presentable speed (C02540) [864](#)
- Max. rot. ang. aft. mns. swtch. (C02653) [890](#)
- Max. speed (C02703) [898](#)
- Max. speed [rpm] (C02704) [898](#)
- Maximum acceleration exceeded (error message) [712](#)
- Maximum current [128](#)
- Maximum current (C00022) [746](#)
- Maximum current monitoring [233](#)
- Maximum speed exceeded (error message) [712](#)
- MCTRL\_dnAccelerationAdd (C00804) [829](#)
- MCTRL\_dnBoost (C00814) [831](#)
- MCTRL\_dnDCBusVoltage (C00779) [826](#)
- MCTRL\_dnDeltaMotorPos\_p (C00791) [828](#)
- MCTRL\_dnFieldWeak (C00816) [832](#)
- MCTRL\_dnFluxAct (C00778) [826](#)
- MCTRL\_dnFlyingSpeedAct (C00787) [827](#)
- MCTRL\_dnI2xtLoad (C00790) [828](#)
- MCTRL\_dnImotAct (C00780) [826](#)
- MCTRL\_dnInputJerkCtrl (C00776) [825](#)
- MCTRL\_dnInputTorqueCtrl (C00777) [826](#)
- MCTRL\_dnIxtLoad (C00786) [827](#)
- MCTRL\_dnLoadPosAct (C00771) [824](#)
- MCTRL\_dnLoadPosRefValue (C00813) [831](#)

- MCTRL\_dnLoadSpeedAct (C00773) [825](#)
- MCTRL\_dnMotorFreqAct (C00784) [827](#)
- MCTRL\_dnMotorPosAct (C00770) [824](#)
- MCTRL\_dnMotorPosRefValue (C00812) [831](#)
- MCTRL\_dnMotorSpeedAct (C00772) [825](#)
- MCTRL\_dnMvorAdapt (C00818) [832](#)
- MCTRL\_dnOutputPosCtrlMotor\_s (C00792) [828](#)
- MCTRL\_dnOutputSpeedCtrl (C00775) [825](#)
- MCTRL\_dnPosCtrlAdapt (C00811) [831](#)
- MCTRL\_dnPosCtrlOutLimit (C00808) [830](#)
- MCTRL\_dnPosSet (C00800) [829](#)
- MCTRL\_dnSpeedAdd (C00802) [829](#)
- MCTRL\_dnSpeedCtrlAdapt (C00810) [830](#)
- MCTRL\_dnSpeedCtrlIntegrator (C00815) [831](#)
- MCTRL\_dnSpeedLowLimit (C00805) [829](#)
- MCTRL\_dnSpeedSet\_s (C00817) [832](#)
- MCTRL\_dnTorqueAct (C00774) [825](#)
- MCTRL\_dnTorqueAdd (C00803) [829](#)
- MCTRL\_dnTorqueCtrlAdapt (C00809) [830](#)
- MCTRL\_dnTorqueHighLimit (C00807) [830](#)
- MCTRL\_dnTorqueLowLimit (C00806) [830](#)
- MCTRL\_dwMaxDeviceCurrent (C00789) [828](#)
- MCTRL\_dwMaxEffMotorTorque (C00788) [828](#)
- MCTRL\_dwMaxMotorSpeed (C00781) [826](#)
- MCTRL\_dwMaxMotorTorque (C00782) [827](#)
- MCTRL\_dwMotorVoltageAct (C00783) [827](#)
- MEC history
  - Error number (C1223) [853](#)
  - Flash value (C1222) [853](#)
  - RAM address (C1220) [852](#)
  - RAM value (C1221) [852](#)
- Memory distribution for cam data [559](#)
- Memory module
  - Faulty file system (error message) [641](#)
  - File system has been formatted (error message) [674](#)
  - File system has been restored (error message) [674](#)
- Memory module Firmw. Rev. (C00220) [771](#)
- Memory module has been changed (error message) [640](#)
- Memory module has been removed (error message) [636](#)
- Memory module is defect or missing (error message) [635](#), [638](#)
- Memory module is missing (error message) [635](#)
- Messages - motor interface (C02560) [868](#)
- Meters
  - Brake chopper overload (C01203) [850](#)
  - DC bus overvoltage (C01205) [850](#)
  - Heatsink overtemp. (C01208) [850](#)
  - Housing overtemp. (C01209) [850](#)
  - Internal (C01210) [851](#)
  - Ixt overload (C01204) [850](#)
  - Mains switching (C01206) [850](#)
  - Power section overload (C01212) [851](#)
- Min. S-ramp time (C02706) [898](#)
- Minimum brake resistance (C00134) [758](#)
- Minimum starting torque (C02606) [878](#)
- MM440 [851](#), [852](#)
- Modulation modes [110](#)
- MOL\_dnState (C02780) [907](#)
- MOL\_SetpointCurrent (C02779) [907](#)
- Moment of inertia (C00273) [773](#)
- Monitoring [617](#)
- Monitoring of limit positions [512](#)
- Mot. overload protection (I<sup>2</sup>t) (C00120) [755](#)
- Mot. overload warning threshold (C00127) [756](#)
- Motor
  - Actual current value > C00620 (error message) [664](#)
  - Actual speed value > C00596 (error message) [665](#)
  - Calculated e.m.f. factor unrealistic (error message) [660](#)
  - Calculated flux factor unrealistic (error message) [661](#)
  - Calculated leakage inductance unrealistic (error message) [663](#)
  - Calculated motor impedance unrealistic (error message) [659](#)
  - Calculated mutual inductance unrealistic (error message) [659](#), [660](#)
  - Calculated rotor resistance unrealistic (error message) [660](#)
  - Calculated rotor time constant unrealistic (error message) [661](#)
  - Device current too low for rated magnetisation (error message) [660](#)
  - Overtemperature (error message) [653](#)
  - Phase resistance too high (error message) [659](#)
  - PTC has triggered (error message) [655](#)
  - Rated current < rated magnetising current (error message) [660](#)
  - Temperature > C00121 (error message) [653](#)
  - Thermal detector is defect (error message) [655](#)
- Motor - magnetising current (C00092) [754](#)
- Motor - mutual inductance (C00079) [752](#)
- Motor - number of pole pairs (C00059) [749](#)
- Motor brake
  - Angular drift with closed brake too high (error message) [709](#)
  - Motor brake
    - Autom. activated after waiting time has elapsed (error message) [709](#)
    - Status monitoring error (error message) [710](#)
- Motor control
  - Task overflow (error message) [662](#)
- Motor cosine phi (C00091) [753](#)
- Motor current (C00054) [747](#)
- Motor data are inconsistent (error message) [659](#), [662](#)
- Motor encoder [248](#)
  - Module selected in C00495 not available (error message) [665](#)
- Motor encoder selection (C00495) [803](#)
- Motor holding brake [521](#)
- Motor holding brake control module E94AZHA0051 [529](#)
- Motor holding brake control module E94AZHX0051 [530](#)
- Motor interface [118](#)
  - % signals (C02568) [870](#)
  - Dig. signals (C02569) [870](#)
- Motor load I<sup>2</sup>t > C00120 (error message) [657](#)
- Motor load I<sup>2</sup>t > C00127 (error message) [656](#)



Motor mounting direction (C02527) [861](#)  
Motor operating temperature (C01194) [847](#)  
Motor parameter identification was cancelled (error message) [669](#)  
Motor phase failure [229](#)  
Motor phase failure monitoring [229](#)  
Motor phase failure threshold (C00599) [812](#)  
Motor phase failure volt. threshold (C02867) [917](#)  
Motor protection [128](#), [233](#)  
Motor reference speed (C00011) [745](#)  
Motor rotor resistance (C00082) [752](#)  
Motor rotor time constant (C00083) [752](#)  
Motor speed [128](#)  
Motor standstill time constant (C00494) [803](#)  
Motor stator leakage inductance (C00085) [753](#)  
Motor stator resistance (C00084) [752](#)  
Motor switched off (error message) [673](#)  
Motor temp. feedback system (C01193) [847](#)  
Motor temperature  
Module selected in C01193 not available (error message) [666](#)  
Motor temperature (C00063) [749](#)  
Motor temperature monitoring (PTC) [227](#)  
Motor thermal sensor (C01190) [846](#)  
Motor voltage (C00052) [747](#)  
Multiturn resolution (C02761) [904](#)  
MXI1  
CAN module is missing or incompatible (error message) [685](#)  
Digital frequency module is missing or incompatible (error message) [684](#)  
Ethernet module is missing or incompatible (error message) [684](#)  
ICM module is missing or incompatible (error message) [685](#)  
Module changed during operation (error message) [636](#)  
Module has been changed (error message) [639](#)  
Module is defect or missing (error message) [637](#)  
Module is missing or incompatible (error message) [683](#)  
PROFIBUS module is missing or incompatible (error message) [684](#)  
Wrong module (error message) [638](#)  
MXI2  
CAN module is missing or incompatible (error message) [685](#)  
Digital frequency module is missing or incompatible (error message) [685](#)  
Ethernet module is missing or incompatible (error message) [684](#)  
ICM module is missing or incompatible (error message) [685](#)  
Module changed during operation (error message) [636](#)  
Module has been changed (error message) [640](#)  
Module is defect or missing (error message) [637](#)  
Module is missing or incompatible (error message) [683](#)  
PROFIBUS module is missing or incompatible (error message) [684](#)  
Wrong module (error message) [639](#)

## N

Negative direction of rotation limited (error message) [711](#)  
Negative limit switch has triggered (error message) [709](#)  
Negative software limit switch overtravelled (error message) [710](#)  
Network management telegram (NMT) [307](#)  
New application loaded (error message) [647](#)  
NMT (network management) [307](#)  
No heartbeat signal detected (error message) [690](#)  
No parameters for module in MXI1 (error message) [689](#)  
No parameters for module in MXI2 (error message) [689](#)  
No. of CRC cycles (C00618) [816](#)  
Node address [303](#)  
Node guarding event [334](#)  
Node guarding protocol [331](#)  
Node ID [303](#)  
Node life time [333](#)  
Noise signal activation (C462) [802](#)  
Noise signal amplitude (C658) [821](#)  
Noise signal period (C659) [822](#)  
Number Of Cam Data Points (C02922) [922](#)  
Number Of Cam Tracks (C02919) [921](#)  
Number Of Cont Data Points (C02942) [924](#)  
Number Of Cont Tracks (C02939) [923](#)  
Number of encoder increments (C00420) [798](#)  
Number of Pos Data Points (C02962) [925](#)  
Number of Pos Tracks (C02959) [925](#)

## O

observation software limit positions (C02720) [902](#)  
Offset actual pos. value/setp. (C02578) [872](#)  
Online change mode [567](#)  
Online Change Mode (C02905) [920](#)  
Online Change State (C02906) [920](#)  
Operating mode (C02770) [905](#)  
Operating mode brake (C02580) [873](#)  
Operation with increased continuous power [112](#)  
Optimising response to setpoint changes [157](#)  
Overcurrent detected (error message) [661](#)  
overload [112](#)

## P

Parameter error information (C217) [771](#)  
Parameter set  
Type of standard device has been changed (error message) [688](#)  
Version conflict (error message) [688](#)  
Parameter set faulty (error message) [686](#)  
Parameter set loaded (error message) [687](#)  
Parameter set restored (error message) [687](#)  
Parameter set saved (error message) [687](#)  
Parameter set switching [86](#)  
Parameter sets [86](#)  
Password entry [566](#)

- Password for cam data [560](#)
  - PDO delay [316](#)
  - PDO mapping (MXI1)
    - configuration faulty (error message) [649](#)
  - PDO mapping (MXI2)
    - configuration faulty (error message) [650](#)
  - PDO synchronisation [313](#)
  - Permissible angle of rotation (C02595) [875](#)
  - Permissible direction of rot. (C02707) [899](#)
  - PF\_dnMotorAcc\_x (C02685) [895](#)
  - PF\_dnPositionSet\_p (C02688) [895](#)
  - PF\_dnSpeedAdd1\_s (C02686) [895](#)
  - Phase controller gain (C00254) [772](#)
  - Phase controller output (C02557) [868](#)
  - Phase currents (C00055) [748](#)
  - Plant parameters [127](#)
  - PLC configuration invalid (error message) [652](#), [669](#), [675](#), [708](#)
  - PLI 360° absolute current amplitude (C00645) [820](#)
  - PLI 360° current amplitude (C00641) [819](#)
  - PLI 360° result in C58 (C02872) [918](#)
  - PLI 360° traversing direction (C00643) [819](#)
  - PLI min. motion absolute cur. amp. (C00651) [821](#)
  - PLI min. mov. reset time (C00649) [821](#)
  - PLI min.mov. curr. amplitude (C00646) [820](#)
  - Pointer access in impermissible memory area (error message) [649](#)
  - Pole position (C00058) [748](#)
  - Pole position identification [68](#), [69](#), [575](#)
  - Pole position recognition cancelled (error message) [673](#)
  - PolePosId 360° fault tol. (C00644) [820](#)
  - PolePosId 360° ramp time (C00642) [819](#)
  - PolePosId min.mov. cur.rise rate (C00647) [820](#)
  - PolePosId min.mov. gain (C00648) [821](#)
  - PolePosId min.mov. max.perm.mov. (C00650) [821](#)
  - PolePosition setpoint (C02788) [909](#)
  - PolePositionIdentification
    - Dig. signals (C02789) [909](#)
  - Pos Data Point Choice (C02963) [926](#)
  - Pos Track Choice (C02960) [925](#)
  - Pos. contr. limitation (C02556) [868](#)
  - Pos. contr. output (C02558) [868](#)
  - POS\_dnProfileSpeed\_s (C02676) [893](#)
  - POS\_dnState (C02675) [893](#)
  - POS\_dwActualProfileNumber (C02674) [892](#)
  - Position control structure (C02570) [871](#)
  - Position controller gain (C02553) [867](#)
  - Position controller reset time (C02554) [867](#)
  - Position encoder [249](#)
    - Module selected in C00490 not available (error message) [665](#)
  - Position encoder mounting dir. (C02529) [862](#)
  - Position encoder selection (C00490) [803](#)
  - Position follower [490](#)
    - % signals (C02687) [895](#)
    - Dig. signals (C02689) [895](#)
  - Position setpoint (enc. eval.) (C02573) [871](#)
  - Position setpoint (mctrl) (C02552) [867](#)
  - Position target outside the software limit positions (error message) [712](#)
  - Position value faulty (error message) [693](#)
  - Positioning [479](#)
    - % signals (C02677) [893](#)
    - Dig. signals (C02679) [894](#)
    - Pos. signals (C02678) [893](#)
  - Positive direction of rotation limited (error message) [710](#)
  - Positive limit switch has triggered (error message) [708](#)
  - Positive software limit switch overtravelled (error message) [710](#)
  - Power section incompatible (error message) [638](#)
  - Power section is defect (error message) [635](#), [637](#), [672](#)
  - Power section was changed (error message) [639](#)
  - Power-on time meter (C00179) [765](#)
  - PPI activation (C02785) [908](#)
  - PPI mode (C02786) [908](#)
  - PPI\_dnState (C02787) [908](#)
  - Pre-defined error field (I-1003) [345](#)
  - Producer heartbeat time (I-1017) [351](#)
  - Product change-over [572](#)
  - Product Choice (C02911) [921](#)
  - Product Count (C02908) [920](#)
  - Product Count (C02912) [921](#)
  - Product Name (C02910) [921](#)
  - Profile data [557](#)
  - Program auto-start (C02104) [858](#)
  - Program name (C02113) [859](#)
  - Program runtime (C02109) [858](#)
  - Program status (C02108) [858](#)
  - Progress of device command (C00008) [745](#)
  - Project is not available (error message) [682](#)
  - Project is not loaded (error message) [682](#)
  - PTC [227](#)
- ## Q
- QSP [393](#)
  - Quick stop [393](#)
    - Dig. signals (C02619) [880](#)
  - Quick stop by (source) (C00159) [762](#)
  - Quick stop S-ramp time (C00106) [754](#)
- ## R
- Rated motor current (C00088) [753](#)
  - Rated motor current. See rated motor current
  - Rated motor frequency (C00089) [753](#)
  - Rated motor power (C00081) [752](#)
  - Rated motor speed (C00087) [753](#)
  - Rated motor voltage (C00090) [753](#)
  - Rated power - brake resistor (C00130) [757](#)
  - Rated quantity of heat for brake res. (C00131) [757](#)

- React. brake transist. lxt > C00570 (C00569) [805](#)
  - React. CPU temperature > C00126 (C00589) [810](#)
  - React. device overload > C00123 (C00604) [813](#)
  - React. heat sink temp. > C00122 (C00582) [808](#)
  - React. motor overload > C00127 (C00606) [813](#)
  - React. motor temp. > C00121 (C00584) [808](#)
  - Read error service register (error message) [651](#)
  - Real-time clock [851](#), [852](#)
    - Battery empty, time lost (error message) [643](#)
    - Change battery (error message) [642](#)
  - Real-time clock is defective (error message) [642](#)
  - Red. brake chopper threshold (C00181) [766](#)
  - Ref. for Accel. time of brake (C02601) [877](#)
  - Ref. for decel. time of stop (C02612) [879](#)
  - Ref. for quick stop dec. time (C00107) [755](#)
  - Ref. pos. after mains switching (C02652) [890](#)
  - Reference
    - Brake chopper utilisation (C00133) [758](#)
  - Reference search [427](#)
  - Reference setting [427](#)
  - Reference speed (C02544) [865](#)
  - Reference speed motor [128](#)
  - Reference S-ramp time (C02545) [865](#)
  - Required licence missing (error message) [683](#)
  - Required safety module (C00214) [771](#)
  - Required safety module (C214) [371](#)
  - Reset error message [117](#), [625](#)
  - Resol. of an encoder revolution (C00100) [754](#)
  - Resolution of a unit (C02532) [863](#)
  - Resolver
    - Calculated acceleration unrealistic (error message) [665](#)
    - Gain (C02862) [916](#)
    - Open circuit (error message) [663](#)
    - Phase correction (C02863) [917](#)
  - Resolver - number of pole pairs (C00080) [752](#)
  - Resolver error compensation [266](#)
  - Resp to new firmw. standard dev. (C00635) [818](#)
  - Resp. temp. sensor motor X7/X8 (C00594) [811](#)
  - Resp. to brake res. i<sup>2</sup>xt > C00572 (C00571) [805](#)
  - Resp. to brake resist. overtemp. (C00574) [806](#)
  - Resp. to CAN bus OFF (C00595) [811](#)
  - Resp. to CAN heartbeat error (C00613) [815](#)
  - Resp. to CAN life guarding error (C00614) [816](#)
  - Resp. to CAN node guarding error (C00612) [815](#)
  - Resp. to CAN-RPDOx error (C00591) [810](#)
  - Resp. to comm. error with MXI1 (C01501) [853](#)
  - Resp. to comm. error with MXI2 (C01502) [854](#)
  - Resp. to comm. task overflow (C01230) [853](#)
  - Resp. to DC bus overvoltage (C00600) [813](#)
  - Resp. to encoder comm. error (C00601) [813](#)
  - Resp. to encoder open circuit (C00580) [807](#)
  - Resp. to encoder pulse deviation (C00621) [817](#)
  - Resp. to external fault (C00581) [808](#)
  - Resp. to failure heatsink fan (C00610) [814](#)
  - Resp. to failure integral fan (C00611) [814](#)
  - Resp. to failure t. sensor drive (C00588) [810](#)
  - Resp. to imp. device config. (C00615) [816](#)
  - Resp. to limitation (C02716) [901](#)
  - Resp. to max. speed reached (C00607) [814](#)
  - Resp. to motor current > C00620 (C00619) [817](#)
  - Resp. to motor KTY overtemp. (C00583) [808](#)
  - Resp. to motor overtemp. PTC (C00585) [809](#)
  - Resp. to motor phase failure (C00597) [812](#)
  - Resp. to new module in MXI1 (C00636) [818](#)
  - Resp. to new module in MXI2 (C00637) [818](#)
  - Resp. to open circuit AIN1 (C00598) [812](#)
  - Resp. to overload brake trans. (C00573) [806](#)
  - Resp. to pole pos. id. monit. (C00640) [819](#)
  - Resp. to resolver open circuit (C00586) [809](#)
  - Resp. to speed monitoring (C00579) [807](#)
  - Resp. to task overflow (C02111) [859](#)
  - Restart [107](#)
  - Restore default parameters (I-1011) [349](#)
  - Retain memory of the application faulty (error message) [650](#)
  - Retracting from limit switches [411](#)
  - Rotor position (C00060) [749](#)
  - RPDO1 communication parameter (I-1400) [358](#)
  - RPDO1 mapping parameter (I-1600) [360](#)
  - RPDO2 communication parameter (I-1401) [359](#)
  - RPDO2 mapping parameter (I-1601) [361](#)
  - RPDO3 communication parameter (I-1402) [359](#)
  - RPDO3 mapping parameter (I-1602) [361](#)
  - RPDO4 communication parameter (I-1403) [360](#)
  - RPDO4 mapping parameter (I-1603) [361](#)
  - Rr adjustment (C02860) [916](#)
  - Runtime ApplicationTask (C02121) [859](#)
  - Runtime error (error message) [648](#)
  - Runtime IdleTask (C02123) [860](#)
  - Runtime measurement [61](#)
  - Runtime UserTask (C02122) [860](#)
- ## S
- S1 torque characteristic I<sup>2</sup>xt mon. (C01196) [848](#)
  - Safety instructions [17](#)
  - Safety module [369](#)
    - Incompatible with setting in C00214 (error message) [693](#)
    - Interface [374](#), [510](#)
  - Safety module has been changed (error message) [640](#)
  - Safety module has been removed (error message) [637](#)
  - Safety module is defect or missing (error message) [636](#), [638](#)
  - Safety system [369](#)
  - Saturation characteristic [204](#)
  - Saving of parameters failed (error message) [688](#)
  - Scaling of physical units [24](#)
  - SDO1 server parameter (I-1200) [353](#)
  - SDO10 server parameter (I-1209) [357](#)
  - SDO2 server parameter (I-1201) [354](#)
  - SDO3 server parameter (I-1202) [356](#)

- SDO4 server parameter (I-1203) [356](#)
- SDO5 server parameter (I-1204) [356](#)
- SDO6 server parameter (I-1205) [356](#)
- SDO7 server parameter (I-1206) [357](#)
- SDO8 server parameter (I-1207) [357](#)
- SDO9 server parameter (I-1208) [357](#)
- Select motor control [124](#)
- Select motor control (C00006) [745](#)
- Sensorless vector control (SLVC) [166](#)
- Service code (C00180) [766](#)
- Service code (C02564) [869](#)
- Service code (C1125) [845](#)
- Service code (C1126) [845](#)
- Service code (C1127) [846](#)
- Service code (C1128) [846](#)
- Service code (C1129) [846](#)
- Service code (C1211) [851](#)
- Service code (C1217) [852](#)
- Service code (C1218) [852](#)
- Service code (C132) [757](#)
- Service code (C167) [763](#)
- Service code (C171) [763](#)
- Service code (C175) [765](#)
- Service code (C176) [765](#)
- Service code (C177) [765](#)
- Service code (C198) [767](#)
- Service code (C2850) [914](#)
- Service code (C2851) [914](#)
- Service code (C2852) [914](#)
- Service code (C2854) [915](#)
- Service code (C2856) [915](#)
- Service code (C2857) [916](#)
- Service code (C2864) [917](#)
- Service code (C2868) [917](#)
- Service code (C2869) [917](#)
- Service code (C2870) [918](#)
- Service code (C2996) [926](#)
- Service code (C2997) [926](#)
- Service code (C2998) [926](#)
- Service code (C2999) [926](#)
- Service code (C308) [775](#)
- Service code (C309) [775](#)
- Service code (C310) [775](#)
- Service code (C325) [779](#)
- Service code (C326) [779](#)
- Service code (C327) [779](#)
- Service code (C328) [780](#)
- Service code (C329) [780](#)
- Service code (C330) [780](#)
- Service code (C335) [780](#)
- Service code (C336) [780](#)
- Service code (C337) [780](#)
- Service code (C338) [780](#)
- Service code (C379) [791](#)
- Service code (C395) [795](#)
- Service code (C396) [795](#)
- Service code (C397) [796](#)
- Service code (C416) [797](#)
- Service code (C468) [803](#)
- Service code (C512) [804](#)
- Service code (C513) [804](#)
- Service code (C514) [804](#)
- Service code (C515) [804](#)
- Service code (C516) [804](#)
- Service code DataFlash (C1213) [851](#)
- Service password (C00004) [744](#)
- Servo control (SC) [145](#)
- Set time and date (C01215) [852](#)
- Setpoint interpolation (C02550) [867](#)
- Setting of actual speed filter [152](#), [179](#)
- Setting the baud rate for CAN [300](#)
- Setting the CAN node address [299](#)
- Setting the error response [618](#)
- Setting the field weakening for asynchronous machines [159](#)
- Setting the node address for CAN [299](#)
- Setting the S-ramp time [387](#)
- Settings for test mode (C00399) [796](#)
- SF\_dnMotorAcc\_x (C02692) [896](#)
- SF\_dnSpeedAdd\_s (C02693) [896](#)
- Short overview of error messages [626](#)
- Signal flow
  - Encoder evaluation [243](#)
  - Monitoring [217](#)
  - Position follower [492](#)
  - Sensorless vector control [183](#)
  - Servo control for asynchronous motor [164](#)
  - Servo control for synchronous motor [162](#)
  - Speed follower [498](#)
  - Torque slave [503](#)
  - V/f characteristic control [199](#)
  - V/f control [201](#)
- Signal source - speed setpoint (C00275) [773](#)
- Signal source - torque setpoint (C00276) [774](#)
- SLVC
  - Gain - torque controller (C00987) [840](#)
  - Gain of cross current controller (C00986) [840](#)
  - Gain of field current controller (C00985) [840](#)
  - Reset time - torque contr. (C00988) [840](#)
  - Time const.- Para. adj. (C00989) [841](#)
- Software limit positions [512](#)
  - Triggering behaviour [514](#)
- Software limit positions (C02701) [897](#)
- Software limits pos. effective (C02700) [897](#)
- Source - actual position (C2571) [871](#)
- Source add. speed (C02681) [894](#)
- Source for feedf. control brake (C02602) [877](#)
- Source of starting torque (C02588) [874](#)
- Source position setpoint (C02680) [894](#)

Spec. characteristic  
  resistance (C01192) [847](#)  
  temperature (C01191) [847](#)  
Speed act. val. time const. (C00497) [804](#)  
Speed contr. reset time (C00071) [750](#)  
Speed contr.D component (C00072) [751](#)  
Speed controller gain (C00070) [750](#)  
Speed controller output (C00694) [822](#)  
Speed feedforw. control gain (C02561) [869](#)  
Speed follower [496](#)  
  % signals (C02694) [896](#)  
  Dig. signals (C02695) [896](#)  
Speed has been limited (error message) [711](#)  
Speed limitation (C00909) [833](#)  
Speed monitoring tolerance (C00576) [806](#)  
Speed setpoint (enc. eval.) (C02572) [871](#)  
Speed setpoint [%] (C00692) [822](#)  
Speed setpoint [rpm] (C00050) [747](#)  
Speed unit (C02537) [864](#)  
S-ramp time for stop (C02611) [879](#)  
S-ramp time lim. speed (C02711) [900](#)  
SSI encoder [255](#)  
  bit rate (C00423) [798](#)  
  data word length (C00424) [799](#)  
  partword data coding (C00437) [800](#)  
  partword length (C00436) [800](#)  
  partword start position (C00435) [799](#)  
Start acceleration [385](#)  
Starting angle (C02772) [906](#)  
Starting performance [107](#)  
Starting torque 1 (C02586) [874](#)  
Starting torque 2 (C02587) [874](#)  
Starting value I<sup>xt</sup> monitoring (C01197) [848](#)  
State bus [286](#)  
Status  
  Digital inputs (C00443) [801](#)  
  Digital outputs (C00444) [801](#)  
Status DCTRL control input (C00878) [832](#)  
Status displays [608](#)  
Status input monitoring (C02583) [873](#)  
Status word  
  Digital inputs (C02803) [912](#)  
  Digital outputs (C02802) [911](#)  
Status word device control 1 (C00150) [759](#)  
Status word device control 2 (C00155) [760](#)  
Status/Control word MCTRL (C00156) [760](#)  
Stop [389](#)  
Storage capacity for user parameters exceeded (error message) [686](#)  
Store parameters (I-1010) [348](#)  
STP\_bStopActive (C02617) [880](#)  
STP\_dnState (C02616) [880](#)  
Switching frequency (C00018) [746](#)  
Switching frequency reduction [111](#)  
Sync cycle time (C01121) [843](#)

Sync phase position [316](#)  
Sync phase position (C01122) [844](#)  
Sync source (C01120) [843](#)  
Sync telegram [313](#)  
Sync tolerance (C01123) [844](#)  
Sync-PLL increment (C01124) [845](#)  
System block "LS\_Limiter" [370](#)  
System error messages [620](#)  
System event [293](#)  
System task  
  Task overflow (error message) [692](#)  
System task 1  
  Task overflow (error message) [691](#)  
System task 2  
  Task overflow (error message) [691](#)  
System task 3  
  Task overflow (error message) [692](#)  
**T**  
Table of attributes [927](#)  
Target group [13](#)  
Task overflow [109](#), [293](#)  
Task runtimes [61](#)  
Temperature inside the controller (C00062) [749](#)  
Temperature monitoring of a second motor [228](#)  
Terminology used [16](#)  
Test mode motor control (C00398) [796](#)  
Test torque (C02594) [875](#)  
Therm. motor time constant (C00128) [757](#)  
Thermal motor load (I<sup>xt</sup>) (C00066) [750](#)  
Threshold - brake activation (C02581) [873](#)  
Threshold - standstill recognition (C00019) [746](#)  
Threshold 1 for opening brake (C02603) [877](#)  
Threshold 2 for opening brake (C02604) [877](#)  
Threshold max. speed reached (C00596) [811](#)  
Time [851](#), [852](#)  
Time (C02776) [907](#)  
Time constant of actual speed filter [152](#), [179](#)  
Time error - controller interface (error message) [658](#)  
Time for device search function (C00182) [766](#)  
Time unit (C02533) [863](#)  
Time-out torque feedforward control - brake (error message) [713](#)  
Timestamp (C02902) [919](#)  
Tolerance for POS\_bActPosInTarget (C02670) [891](#)  
Tolerance for POS\_bDriveInTarget (C02671) [892](#)  
Torque (C00057) [748](#)  
Torque feedforward control [157](#)  
Torque setpoint (C00056) [748](#)  
Torque setpoint [%] (C00696) [822](#)  
Torque slave [501](#)  
  % signals (C02698) [897](#)  
  Dig. signals (C02699) [897](#)  
Total speed setpoint (C00691) [822](#)

Total torque setpoint (C00695) [822](#)  
Touch probe detection [288](#)  
Touch probe x  
  Delay time (C02810) [913](#)  
TPDO1 communication parameter (I-1800) [362](#)  
TPDO1 mapping parameter (I-1A00) [365](#)  
TPDO2 communication parameter (I-1801) [363](#)  
TPDO2 mapping parameter (I-1A01) [365](#)  
TPDO3 communication parameter (I-1802) [364](#)  
TPDO3 mapping parameter (I-1A02) [366](#)  
TPDO4 communication parameter (I-1803) [364](#)  
TPDO4 mapping parameter (I-1A03) [366](#)  
Track switch-over [572](#)  
Travel range monitoring [506](#)  
Traversing range (C02528) [862](#)  
TTL encoder signal evaluation (C00427) [799](#)

## U

Ultimate motor current I<sub>ult</sub> [128](#), [233](#)  
Ultimate motor current I<sub>ult</sub> (C00620) [817](#)  
Undervoltage (LU) threshold (C00174) [765](#)  
Unit [36](#)  
Unit (C02525) [861](#)  
Unknown error (error message) [626](#), [634](#)  
Update cam data [562](#)  
Used time unit (C02534) [863](#)  
Used unit (C02535) [863](#)  
User code  
  Memory load (C02110) [858](#)  
User Password (C02900) [918](#)  
User-defined unit (C02526) [861](#)  
UserTask  
  Overflow (error message) [647](#)

## V

V/f control (VFCplus) [184](#), [200](#)  
VFC  
  Activat. interpol. point n (C00954) [835](#)  
  Frequency interpol. point n (C00952) [834](#)  
  Frequency setpoint (C00998) [842](#)  
  Gain - I<sub>max</sub> controller (C00963) [837](#)  
  Gain - oscillation damping (C00967) [837](#)  
  Gain - slip compensation (C00965) [837](#)  
  Gain - speed controller (C00972) [838](#)  
  Influence - speed controller (C00971) [838](#)  
  Limitation - oscill. damp. (C00969) [838](#)  
  Load - cw/ccw-operation (C00961) [836](#)  
  Load adjustment (C00962) [836](#)  
  min. inh-time aft. overvolt. (C00977) [839](#)  
  Override point of field weakening (C00980) [840](#)  
  ramp-end frequ. - oscill. damp. (C00970) [838](#)  
  Reset time - I<sub>max</sub> contr. (C00964) [837](#)  
  Reset time - speed contr. (C00973) [839](#)  
  Time const. - oscill. damp. (C00968) [838](#)  
  Time const. slip comp. (C00966) [837](#)

V/f base frequency (C00951) [833](#)  
V/f characteristic shape (C00950) [833](#)  
V/f voltage boost (C00960) [836](#)  
V<sub>max</sub> reduction (C00955) [835](#)  
Voltage interpol. point n (C00953) [834](#)  
VVC current setpoint (C00957) [835](#)  
VVC gain (C00958) [836](#)  
VVC reset time (C00959) [836](#)  
VFCplus [200](#)  
Violation of time slice (error message) [659](#)  
Voltage reserve (C02871) [918](#)

## W

Waiting time - brake activation (C02593) [875](#)  
Waiting time - state monitoring (C02591) [875](#)  
Warning thres. brake resistor (C00572) [806](#)  
Warning thres. brake transistor (C00570) [805](#)  
Warning threshold device util. (C00123) [756](#)  
Warning threshold motor temperature (C00121) [756](#)  
Watchdog cycle is greater than task cycle (error message) [651](#)  
Width of current setpoint filter (C00271) [772](#)

## X

X8 (encoder signal) [263](#)

# FEEDBACK



## Your opinion is important to us

These instructions were created to the best of our knowledge and belief to give you the best possible support for handling our product.

If you have suggestions for improvement, please e-mail us to:

[feedback-docu@Lenze.de](mailto:feedback-docu@Lenze.de)

Thank you for your support.

*Your Lenze documentation team*



Lenze Automation GmbH

Hans-Lenze-Str. 1

D-31855 Aerzen

Germany

HR Hannover B 205381

☎ +49 (0)51 54 / 82-0

📠 +49 (0)51 54 / 82-28 00

✉ [sales.de@lenze.de](mailto:sales.de@lenze.de)

🌐 [www.Lenze.com](http://www.Lenze.com)

#### Service

Lenze Service GmbH

Breslauer Straße 3

D-32699 Extertal

Germany

☎ 00 80 00 / 24 4 68 77 (24 h helpline)

📠 +49 (0)51 54 / 82-11 12

✉ [service.de@lenze.de](mailto:service.de@lenze.de)