

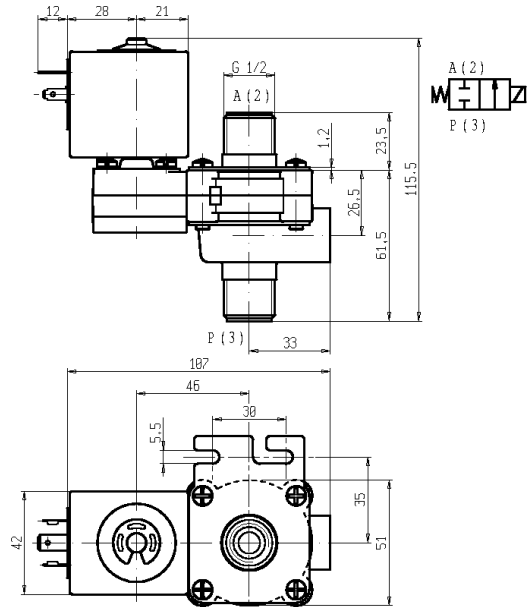

SOLENOID VALVE - DRY
2/2 - NC (Normally closed)
Direct acting - Total isolation
G1/2

D132V23

NON STANDARD



► **GENERAL FEATURES**

Direct acting, total isolation solenoid valve: the actuator is totally isolated from the fluid so that the wetted parts are just the body and the diaphragm.

Possibility of disassembling for inspection.

Core duly coated by PTFE (polytetrafluoroethylene) based self lubricating material.

Suitable to shut off liquid and gaseous fluids (verify the compatibility of fluid with materials in contact).

► **TECHNICAL FEATURES**

<i>Maximum allowable pressure (PS)</i>	2 bar
<i>Opening time</i>	~30ms
<i>Closing time</i>	~30ms
<i>Fluid temperature</i>	-10°C +90°C
<i>Max viscosity</i>	5°E (~37 cStokes or mm ² /s)

► **MATERIALS IN CONTACT WITH FLUID**

<i>Body</i>	PPS (see notes)
<i>Sealing</i>	FPM

► **COIL**

<i>Continuous duty</i>	ED 100%
<i>Encapsulation material</i>	PET (polyethylene) fibreglass reinforced
<i>Coil insulation class</i>	F (140°C)
<i>Ambient temperature</i>	-10°C +60°C
<i>Electric connections</i>	DIN 46340 – 3 poles connectors (EN 175301-803)
<i>Protection degree</i>	IP 65 (EN 60529) with plug connector
<i>Voltagess</i>	DC 12-24V (+10% -5%)
	AC 24V/50Hz - 110V/50Hz (120V/60Hz) - 230V/50Hz (+10% -15%)
	(Other voltages and frequencies on request).

Port size ISO 228	Orifice size (mm)	Differential pressure (bar)						Kv (m ³ /h)	Series and type		Power absorption			Sealings	Notes	Weight (kg)
		Δp min	Δp max				Valve		Coil	AC (VA)		DC (W)				
			Gases		Liquids					Inrush	Holding					
			AC	DC	AC	DC										
G 1/2	9	0	1,6	0,25	1,6	0,25	1,6	D132V23	Z130A	44	24	13	FPM	-	0,530	

► **NOTES**

- Sealings : FPM = Fluoro-carbon elastomer
- Body: PPS (Polyphenylene-sulfide) fibreglass reinforced, WRAS/KTW and NSF approval

► SPARE PARTS

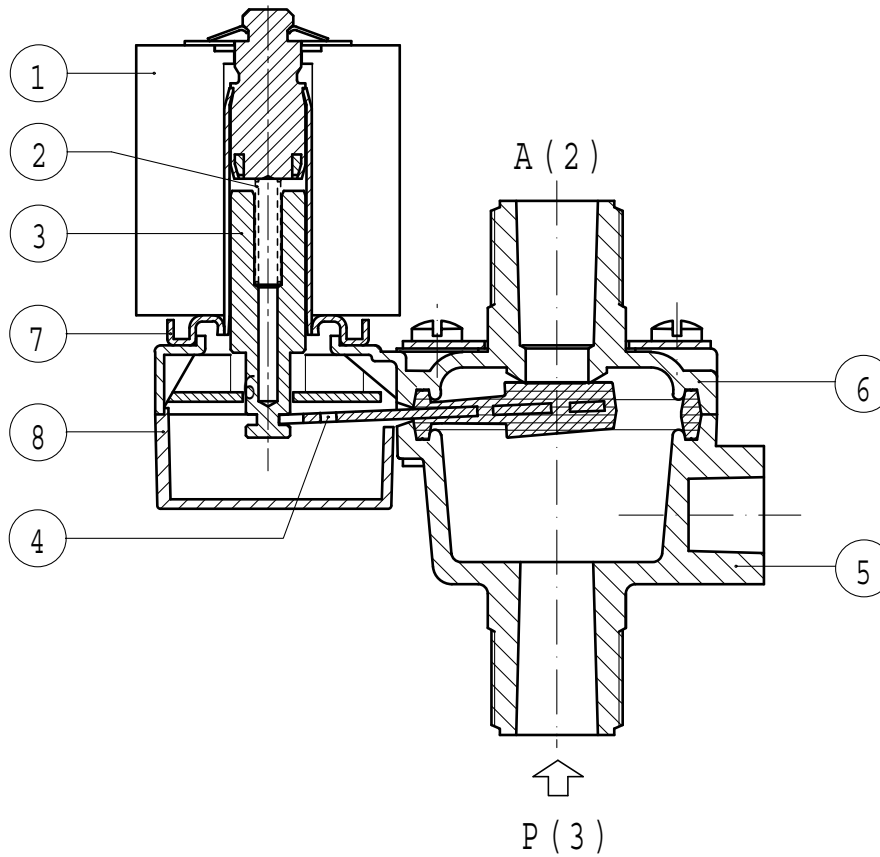

Kit description	Kit P.N.	Consisting of:
Body kit	G2986604	Upper body pos.6 Lower body pos.5
Core kit	G2992801	Core return spring pos.2 Core pos.3
Lever seal	3037301R	Lever seal pos.4
Cover	2985703R	Cover pos.8
Guide assembly	3077401R	Guide assembly pos.7
Coil	Z130A	Coil pos. 1

► INSTALLATION

- Solenoid valve can be mounted in any position.
- In case of disassembling for usual maintenance, the fixing screws have to be tightened at 1,5 Nm max torque.
- Maximum driving torque of the pipe fittings for thread connections = 15Nm.