

Index

1. Proper Use	3
2. Safety Precautions	3
3. LED Warning	3
4. EC Declaration of Conformity	3
5. Technical Data	4
5.1. Connection Diagram	5
5.2. Housing Dimensions	5
5.3. Control Panel	5
5.4. Complementary Products	6
6. Installation Instructions	6
7. Commissioning	7
7.1. General Device Information	7
7.2. Factory Default Settings	7
8. Function description	7
8.1. Switching the Output Stage to and from PNP, NPN and Push-Pull	7
8.2. Setting the Switching Threshold with the Teach-In Function	8
8.3. Checking for Correct Function	11
8.4. Readjusting the Switching Threshold with the Key Potentiometer	11
8.5. Delay Times: On-Delay and Off-Delay	11
8.6. Trigger Function at Pin 5	12
8.7. Returning All Sensor Settings to their Default Values	12
8.8. Continuous Read-Out of Intensity Values via the Interface	13
9. Interface	13
10. Maintenance Instructions	14
11. Proper Disposal	14

1. Proper Use

This wenglor product has to be used according to the following functional principle:

Luminescence Sensors emit UV light with a wavelength of 380 nm. If the emitted light strikes a luminescent object, it reflects light within a visible wavelength range of 420–750 nm in accordance with the utilized luminescent substance. This fluorescent effect is exploited by the Luminescence Sensor in order to detect markings which are invisible to the human eye during daylight hours.

2. Safety Precautions

- This operating instruction is part of the product and must be kept during its entire service life.
- Read this operating instruction carefully before using the product.
- Installation, start-up and maintenance of this product should only be carried out by trained personal.
- Tampering with or modifying the product is not permissible.
- Protect the product against contamination during start-up.
- These products are not suited for safety applications.

3. LED Warning

Observe all applicable standards and safety precautions.

Caution

UV radiation from this product.

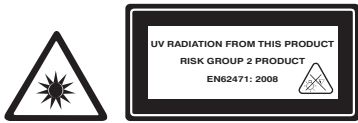

4. EC Declaration of Conformity

The EC declaration of conformity can be found on our website at www.wenglor.com in download area.



RoHS

5. Technical Data

Order-No.	A1P05	A1P16	A2P05	A2P16
Working Range	30...50 mm	16...20 mm	30...50 mm	16...20 mm
Working Distance	40 mm	18 mm	40 mm	18 mm
Receiver Filter	GG 420	GG 420	OG 570	OG 570
Receiving Range	420...750 nm	420...750 nm	570...750 nm	570...750 nm
Switching Hysteresis	< 1 %	< 1 %	< 1 %	< 1 %
Light Source	UV-Light	UV-Light	UV-Light	UV-Light
Wave Length	380 nm	380 nm	380 nm	380 nm
Service Life (Tu = +25 °C)	100000 h	100000 h	100000 h	100000 h
Risk Group (EN 62471)	2	2	2	2
max. Ambient Light	10000 Lux	10000 Lux	10000 Lux	10000 Lux
Light Spot Diameter	5 mm	3 mm	5 mm	3 mm
Power Supply	10...30 V DC	10...30 V DC	10...30 V DC	10...30 V DC
Power Consumption	< 50 mA	< 50 mA	< 50 mA	< 50 mA
Switching Frequency	2500 Hz	2500 Hz	2500 Hz	2500 Hz
Switching Frequency	200 µs	200 µs	200 µs	200 µs
ON-/OFF-Delay	0...10 ms	0...10 ms	0...10 ms	0...10 ms
Time Delay	0...100 ms	0...100 ms	0...100 ms	0...100 ms
Temperature Drift	< 1 %	< 1 %	< 1 %	< 1 %
Temperature Range	-25...60 °C	-25...60 °C	-25...60 °C	-25...60 °C
Switching Outputs	2	2	2	2
Switching Output Voltage Drop	1,5 V	1,5 V	1,5 V	1,5V
Switching Output / Switching Current	200 mA	200 mA	200 mA	200 mA
Short Circuit Protection	yes	yes	yes	yes
Reverse Polarity Protection	yes	yes	yes	yes
Lockable	yes	yes	yes	yes
Teach Mode	ZT, DT, TP	ZT, DT, TP	ZT, DT, TP	ZT, DT, TP
Interface	RS-232	RS-232	RS-232	RS-232
Baud Rate	38400 Bd	38400 Bd	38400 Bd	38400 Bd
Digital Inputs	2	2	2	2
Adjustment	Teach-In	Teach-In	Teach-In	Teach-In
Housing	Plastic	Plastic	Plastic	Plastic
Protection Mode	IP67	IP67	IP67	IP67
Connection	M12×1, 8-pin	M12×1, 8-pin	M12×1, 8-pin	M12×1, 8-pin
Protection Class	III	III	III	III

ZT: Two-Point Teach-In

DT: Dynamic Teach-In

TP: Key Potentiometer

5.1. Connection Diagram

736

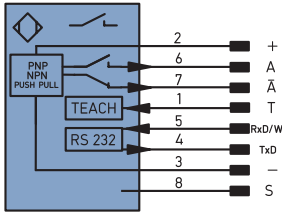

- + 10 to 30 V supply power
- A Switching output (normally open)
- A̅ Switching output (normally closed)
- RxD/W Interface input lead
- W: Trigger input
- TxD Interface output lead
- T External Teach-In input
- Minus
- S Shield

5.2. Housing Dimensions

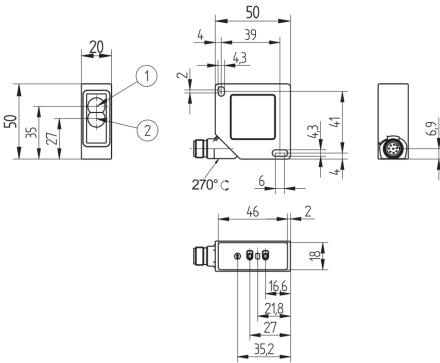

- 1 = Transmitter Diode
- 2 = Receiver Diode

5.3. Control Panel

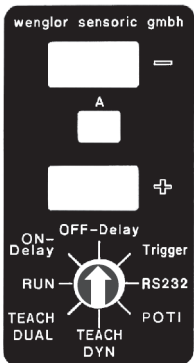

- ⊖ = Minus key (with LED)
- A = Output switching status display
- ⊕ = Plus key (with LED)
- ON-Delay = On-delay
- OFF-Delay = Off-delay
- Trigger = Trigger mode operation
- RS-232 = Interface operation
- TEACH DUAL = Two-Point Teach-In
- TEACH DYN = Dynamic Teach-In
- POTI = Potentiometer function
- RUN = Run function
- ⌚ = Rotary selector switch

5.4. Complementary Products

Suiting Connection Technology No. **380**

Suiting Mounting Technology No. **80**

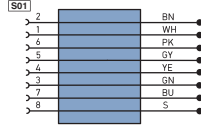

Interface Cable S232W3

6. Installation Instructions

During use of the Sensors, applicable electrical and mechanical regulations, standards and safety precautions must be adhered to. The Sensor must be protected against mechanical influences.

These Sensors are not suitable for safety applications!

The Sensor must be securely mounted during operation.

A1P16
A2P16

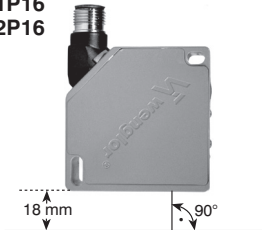

A1P05
A2P05



7. Commissioning

7.1. General Device Information

The wenglor® AxP luminescence Sensor is available in two different versions as regarding the receiver filter. The A1Pxx is equipped with a type GG420 receiver filter which allows blue to pass, and the A2Pxx with a type OG570 receiver filter which allows yellow-green to pass. The AxP16 series has a working distance of 18 mm, and the AxP05 series has a working distance of 40 mm.

Applications:

Sensor	Receiver Filtering	Applications	Working Distance
A1P05	420 nm	Blue luminescing surfaces	40 mm
A2P05	570 nm	Yellow-green luminescing surfaces	40 mm
A1P16	420 nm	Blue luminescing surfaces	18 mm
A2P16	570 nm	Yellow-green luminescing surfaces	18 mm

Table 1

7.2. Factory Default Settings

Function	Factory Default Setting
On-delay	off
Off-delay	off
Output stage	PNP
Teach-In mode for external Teach-In	Two-Point
Automatic intensity read-out via RS-232	off

Table 4

8. Function description

8.1. Switching the Output Stage to and from PNP, NPN and Push-Pull

wenglor® AxP luminescence Sensors are equipped with programmable output stages. Either PNP, NPN or Push-Pull can be selected. All outputs are reconfigured when the output stage is switched.

Activating the Output Stage Setup Mode

- Set the rotary selector switch \dot{Y} to POT1
- Press and hold the plus and minus keys
 - è The LEDs at the plus and minus keys lights up
 - è The LEDs at the plus and minus keys go out after 1 second
 - è The switching status indicator blinks
- Release both keys, namely and
 - è The currently selected output stage operating mode is displayed (see "Table 1")
 - è Depending upon the Sensor's current switching status, the switching status indicator blinks rhythmically after approximately 2 seconds (output switched), or lights up continuously with brief interruptions (output not switched).

Output Stage Selection Indicator

Output stage	LED at minus key \ominus	LED at plus key \oplus
NPN	on	off
PNP	off	on
Push-Pull	on	on

Table 2

Checking the Momentary Setting

- Activate the output stage setup mode (see “Activating the Output Stage Setup Mode” on page 7)
 - è The momentary setting is indicated by the LEDs at the keys in accordance with table 1
- Activating the PNP Mode
 - Press the plus key
 - Release the plus key
 - è The LED at the plus key lights up
 - è The LED at the minus key is off
 - è The PNP mode is activated
- Activating the NPN Mode
 - Press the minus key
 - Release the minus key
 - è The LED at the plus key is off
 - è The LED at the minus key lights up
 - è The NPN mode is activated

Activating the Push-Pull Mode

- Simultaneously press the plus and minus keys
- Simultaneously release the plus and minus keys
 - è The LED at the plus key lights up
 - è The LED at the minus key lights up
 - è The Push-Pull mode is activated

Exiting the Setup Mode

- Set the rotary selector switch \dot{Y} to RUN

8.2. Setting the Switching Threshold with the Teach-In Function

With the help of integrated Teach-In technology, the Sensor automatically calculates appropriate settings based upon currently acquired values and saves them to memory after the corresponding key has been activated, or after an external control signal has been received.

Two-Point Teach-In

The marking to be recognized is first taught into the Sensor in two steps, and the background is taught in subsequently. The Sensor then automatically calculates the ideal switching threshold based upon these two values. The brightness relationship of the two intensities is irrelevant as far as switching characteristics are concerned. Sensor output A is activated when the Sensor recognizes the intensity value which was taught in first. Sensor output A is deactivated when the Sensor recognizes the intensity value which was taught in second.

Teach in the first intensity value:

- Set the rotary selector switch \dot{Y} to TEACH DUAL
- Align the Sensor spot to the marking
- Press and hold the plus key
 - è The LED at the plus key lights up
 - è The LED at the plus key goes out after 1 second and the output switching status indicator A blinks
- The LED at the plus key lights up
 - è The LED at the minus key blinks
 - è The intensity value of the marking is saved to buffer memory

Teach in the second intensity value:

- Align the Sensor spot to the background
- Briefly press the minus key and then release
 - è The switching threshold is calculated and saved to memory
 - è The LED at the minus key stops blinking
- Check for correct function

If the difference between the two acquired intensity values is too small, the output switching status indicator **A** blinks rapidly for approximately 3 seconds, and switching thresholds are not updated.

Dynamic Teach-In

All intensity values from the background and the marking are continuously acquired with this function. The ideal switching threshold is calculated based upon these values.

This function is intended for applications where the objects to be scanned move continuously at a constant speed, and cannot be brought to a standstill within the production process.

Example 1: Recognition of luminescent adhesive strips on unprinted packaging material, which is fed in a continuous fashion: when Teach-In operation is initialized, the spot must be aligned to the background.

Example 2: Recognition of luminescent markings on rapidly rotating parts: dynamic Teach-In operation can be initialized regardless of spot alignment.

Initialise recording mode operation:

- Set the rotary selector switch \dot{Y} to TEACH DYN
- Press and hold the plus key
 - è The LED at the plus key lights up
 - è The LED at the plus key goes out after 1 second and the output switching status indicator A blinks
- Release the plus key
 - è The LED at the minus key blinks: recording mode operation is active
 - è Intensity values are continuously recorded

Exit recording mode operation:

- Briefly press the minus key and then release
 - è Recording is stopped
 - è The switching threshold is calculated and saved to memory
- Check for correct function

If the difference between the two acquired intensity values is too small, the output switching status indicator **A** blinks rapidly for approximately 3 seconds, and switching thresholds are not updated.

External Teach-In

If the control panel is inaccessible, the Sensor can be configured via the external Teach-In input (pin 1). The last Teach-In mode selected at the control panel is always active (i.e. Two-Point or dynamic Teach-In).

External Two-Point Teach-In

Teach in the first intensity value:

- Set the rotary selector switch \dot{Y} to RUN
- Apply a voltage of 10 to 30 V to external Teach-In input T (pin 1) for at least 0.3 s
- Disconnect voltage from Teach-In input T (pin 1)
 - è The LED at the minus key blinks
 - è The intensity value of the marking is saved to buffer memory
-

Teach in the second intensity value:

- Align the Sensor spot to the background
- Apply a voltage of 10 to 30 V to external Teach-In input T (pin 1) for at least 0.3 s
- Disconnect voltage from Teach-In input T (pin 1)
 - è The switching threshold is calculated and saved to memory
 - è The LED at the minus key stops blinking
- Check for correct function

If the difference between the two acquired intensity values is too small, the output switching status indicator **A** blinks rapidly for approximately 3 seconds, and switching thresholds are not updated.

External Dynamic Teach-In

Objects to be scanned move at a constant speed.

If no continuous alternating back and forth between the marking and the background occurs during recording, the spot must be aligned to the background when the Teach-In mode is first initialised.

Initialise recording mode operation:

- Set the rotary selector switch \dot{Y} to RUN
- Apply a voltage of 10 to 30 V to external Teach-In input T (pin 1) for at least 0.3 s
- Disconnect voltage from Teach-In input T (pin 1)
 - è The LED at the minus key blinks: recording mode operation is active
 - è Intensity values are continuously recorded

Exit recording mode operation:

- Apply a voltage of 10 to 30 V to external Teach-In input T (pin 1) for at least 0.3 s
- Disconnect voltage from Teach-In input T (pin 1)
 - è Recording is stopped
 - è The switching threshold is calculated and saved to memory
- Check for correct function

If the difference between the two acquired intensity values is too small, the output switching status indicator **A** blinks rapidly for approximately 3 seconds, and switching thresholds are not updated.

8.3. Checking for Correct Function

- Move the object to be scanned
 - è Sensor output A is activated when the Sensor's spot is aligned to the marking
 - è Sensor output A is deactivated when the spot is aligned to the background
- If necessary, the switching threshold can be readjusted with the potentiometer function

8.4. Readjusting the Switching Threshold with the Key Potentiometer

The switching threshold can be manually readjusted with the help of a key potentiometer. The LEDs at the plus and minus keys function as a light scale, and indicate the intensity range within which the configured switching threshold lies.

Aligning the Switching Threshold More Closely to the Marking

- Set the rotary selector switch \dot{Y} to POT1
- Briefly press the plus key and then release
 - è The switching threshold is shifted one step closer to the marking, or
 - è Press and hold the plus key
 - è The switching threshold is continuously shifted closer to the marking
 - è If the LED at the plus key blinks, the limit stop has been reached in the positive direction
- Check for correct function

Aligning the Switching Threshold More Closely to the Background

- Set the rotary selector switch \dot{Y} to POT1
- Briefly press the minus key and then release
 - è The switching threshold is shifted one step closer to the background, or
 - è Press and hold the minus key
 - è The switching threshold is continuously shifted closer to the background
 - è If the LED at the minus key blinks, the limit stop has been reached in the negative direction
- Check for correct function

8.5. Delay Times: On-Delay and Off-Delay

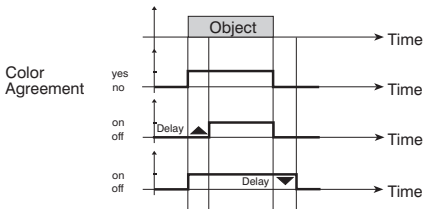

Adjusting On-Delay

- Set the rotary selector switch \dot{Y} to On-Delay
 - è Current On-Delay is displayed (see "Table 1" on page 7)
- Briefly press the plus key
 - è On-delay is increased
- Briefly press the minus key
 - è On-delay is decreased
- Set the rotary selector switch \dot{Y} to RUN

Adjusting Off-Delay

- Set the rotary selector switch \dot{Y} to Off-Delay
 - è Current Off-Delay is displayed (see “Table 1” on page 7)
- Briefly press the plus key
 - è Off-delay is increased
- Briefly press the minus key
 - è Off-delay is decreased
- Set the rotary selector switch \dot{Y} to RUN

Indication of Delay Time Settings

Delay	LED at minus key \ominus	LED at plus key \oplus
0 ms*	1 × blink, pause, 1 × blink	Off
1 ms	2 × blinks, pause, 2 × blinks	Off
2 ms	3 × blinks, pause, 3 × blinks	Off
5 ms	4 × blinks, pause, 4 × blinks	Off
10 ms	Off	1 × blink, pause, 1 × blink
20 ms	Off	2 × blinks, pause, 2 × blinks
50 ms	Off	3 × blinks, pause, 3 × blinks
100 ms	Off	4 × blinks, pause, 4 × blinks

*Default setting

Table 3

8.6. Trigger Function at Pin 5

- Set the rotary selector switch \dot{Y} to trigger
- Apply the trigger signal (PNP) to input W (pin 5)
 - è Triggering is executed by a positive signal edge
 - è The Sensor performs a one-time measurement
 - è The outputs are updated once only
- Disconnect the signal from the trigger input

8.7. Returning All Sensor Settings to their Default Values

Sensor settings can be returned to their original factory default values (see “Table 4” on page 7)

- Set the rotary selector switch \dot{Y} to RS-232
- Simultaneously press the plus and minus keys
 - è The LEDs at both keys start blinking
 - è The LEDs stop blinking after approximately 5 seconds
- Release both keys
- The Sensor has been returned to its factory default settings

8.8. Continuous Read-Out of Intensity Values via the Interface

The Sensor can be configured such that it continuously reads out current intensity values via the interface every 15 ms.

Determine whether or not continuous read-out of intensity values is activated.

- Set the rotary selector switch Ý to RS-232

Switching status indicator	Continuous intensity value read-out
Does not blink	Deactivated
Blinks	Activated

Table 5

Activating Continuous Read-Out of Intensity Values

- Set the rotary selector switch Ý to RS-232
- Press and hold the plus key
- The LED at the plus key lights up
 - è The LED at the plus key goes out after 1 second and the switching status indicator blinks
- Release the plus key
- The switching status indicator continues to blink
- Continuous read-out of intensity values is now activated

Deactivating Continuous Read-Out of Intensity Values

- Set the rotary selector switch Ý to RS-232
- Press and hold the minus key
- The LED at the minus key lights up
 - è The LED at the minus key goes out after 1 second and the switching status indicator blinks
- Release the minus key
- The switching status indicator goes out
- Continuous read-out of intensity values is now deactivated

9. More Settings via the RS-232 Interface

The Sensor is equipped with an RS-232 interface for communication with a device such as a PC or a controller. The interface utilises a software handshake procedure (see protocol specification below).

All Sensor settings can be selected digitally with a PC, and all values generated by the Sensor can be read out at a PC.

Interface Configuration

Baud rate: 38,400 baud, 8 data bits, no parity, 1 stop bit

Connecting the Sensor to a PC, a Controller etc. with the wenglor®-S232W3 Plug Adapter

Plug connectors included with the wenglor® S232W3 plug adapter:

- 8-pin M12 plug connector for connecting the power supply and the outputs
- 8-pin M12 socket connector for direct Sensor connection
- 9-pin M12 sub-miniature socket connector for direct connection to the RS-232 interface at the PC, or the utilized controller

Installing the wenglor® S232W3 plug adapter:

- Switch off the power supply
- Set the rotary selector switch Y to RS-232
- Disconnect the 8-conductor connector cable (S80-xx) from the Sensor
- Connect the S232W3 plug adapter directly to the Sensor
- Connect the 8-conductor connector cable (S80-xx) to the plug adapter
- Connect the 9-pin sub-miniature socket connector to the serial interface at the PC
- Switch the power supply on

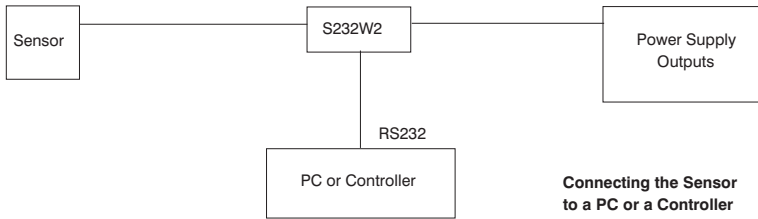

The interface protocol can be downloaded as a PDF document from our website at www.wenglor.com under the “download” heading.

10. Maintenance Instructions

- This wenglor Sensor is maintenance-free.
- It is advisable to clean the lens and the display, and to check the plug connections at regular intervals.
- Do not clean with solvents or cleansers which could damage the device.

11. Proper Disposal

wenglor sensoric gmbh does not accept the return of unusable or irreparable products. Respectively valid national waste disposal regulations apply to product disposal.

