

Installation Instructions

SensaGuard™ 18 mm Plastic Barrel—440N-Z21S16*, 440N-Z21S26*

IMPORTANT: SAVE THESE INSTRUCTIONS FOR FUTURE USE.

ENGLISH:	This instruction sheet is available in multiple languages at www.rockwellautomation.com/literature . Select publication language and type "SensaGuard" in the search field.
GERMAN:	Dieses Instruktionsblatt kann in mehreren Sprachen unter www.rockwellautomation.com/literature gelesen werden. Bitte Ihre Sprache auswählen und "SensaGuard" im Suchfeld eingeben.
FRENCH:	Ces instructions sont disponibles dans différentes langues à l'adresse suivante www.rockwellautomation.com/literature . Sélectionner la langue puis taper "SensaGuard" dans le champ de recherche.
ITALIAN:	La presente scheda d'istruzione è disponibile in varie lingue sul sito www.rockwellautomation.com/literature . Selezionare la lingua desiderata e digitare "SensaGuard" nel campo di ricerca.
SPANISH:	Puede encontrar esta hoja de instrucciones en varios idiomas en www.rockwellautomation.com/literature . Seleccione el idioma de publicación y escriba "SensaGuard" en el campo de búsqueda.
PORTUGUESE:	Esta folha de instruções está disponível em várias línguas em www.rockwellautomation.com/literature . Selecione a língua de publicação e entre com "SensaGuard" no espaço de busca.
POLISH:	Ta kartka z instrukcjami jest dostępna w wielu językach na stronie: www.rockwellautomation.com/literature . Wybierz język publikacji i wpisz w polu poszukiwania "SensaGuard".

Installation Instructions

Installation must be in accordance with the following steps and stated specifications and should be carried out by suitable competent personnel. The unit is not to be used as a mechanical stop. Guard stops and guides must be fitted. Adherence to the recommended maintenance instructions forms part of the warranty.

This device is intended to be part of the safety related control system of a machine. Before installation, a risk assessment should be performed to determine whether the specifications of this device are suitable for all foreseeable operational and environmental characteristics of the machine to which it is to be fitted. Refer to Technical Specifications below for certification information and ratings.

ATTENTION 	The presence of spare actuators compromise the integrity of the safety systems. Personal injury or death, property damage or economic loss can result. Appropriate management controls, working procedures and alternative protective measures should be introduced to control their use and availability.
---	--

WARNING 	Do not defeat, tamper, remove or bypass this unit. Severe injury to personnel could result. The sensor MUST be connected to a Class 2 SELV 24V DC, +10%/-15% power supply.
---	---

Technical Specifications

Safety Classification	Type 4 Interlocking Device per ISO 14119 (Low Coding) PLe, Cat 4 per ISO 13849-1 SIL CL3 per IEC 62061 and IEC 61508
Standards	ISO 14119, IEC 60947-5-3, IEC 61508, IEC 62061, ISO 13849-1, UL508, CSA 22.2 No.14
Certifications	TÜV, CE Marked for all applicable directives, cULus
Functional Safety Data	PFH _D : 1.12 · 10 ⁻⁹

Operating Characteristics

Sensing Distance	18 mm Actuator	30 mm Actuator
Assured Make	15 mm	25 mm
Assured OFF	25 mm	35 mm
Typical Misalignment	(±7 mm in both axes)	
Repeat Accuracy	10% of sensing range	
Max. output current (all outputs)	200 mA	
Input Current	50 mA (no load supply current)	
Operational Current, Min.	≥1 mA DC	
Off-state Current	<0.5 mA DC	
Max. no. of switches, connected in series	Unlimited. See Unit Response Time section on page 4.	
Operating Voltage	24V DC +10%/-15% Class 2 SELV power supply	
Frequency of operating cycle	1 Hz	
Response Time (Off)	54 ms first switch, 18 ms for each additional switch	
Case Material	Polycarbonate	
Actuator Material	Polycarbonate	

Outputs (guard door closed, actuator in place)

Outputs	Description	Status
Safety	2 x PNP, 0.2 A max.	ON (+24V DC)
Auxiliary	1 x PNP, 0.2 A max.	OFF (0V DC)

Environmental

Operating Temperature [C (F)]	-10...+55 ° (14...131 °)
Operating Humidity	5...95% relative
Washdown Rating	NEMA 3, 4X, 12, 13, IP69k
Shock & Vibration	IEC 68-2-27 30 g, 11 ms/IEC 68-2-6 10...55 Hz
Radio Frequency	IEC 61000-4-3 IEC 61000-4-6

Protection

Short-circuit	Incorporated
Current Limitation	Incorporated
Overload	Incorporated
False Pulse	Incorporated
Transient Noise	Incorporated
Reverse Polarity	Incorporated
Overvoltage	Incorporated
Thermal Shutdown/Restart	Incorporated
Electrical Life	10 x 10 ⁶

Dimensions [mm (in.)]

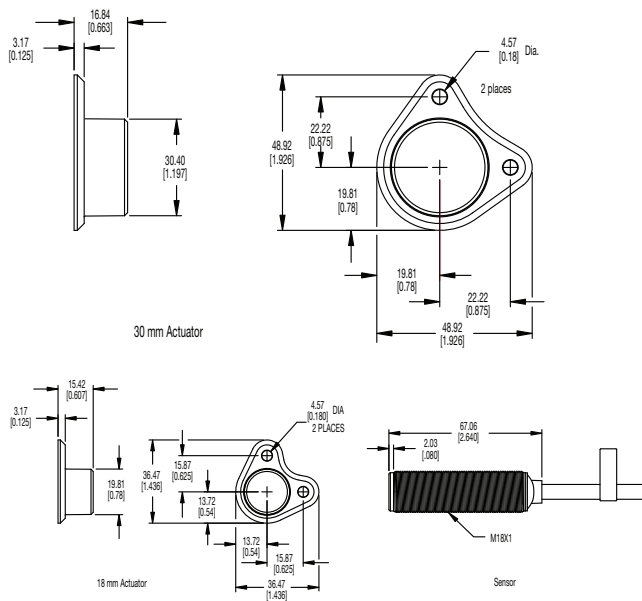

Mode of Operation

Status indicators:

- **“Power/Fault” LED illuminates green:** Door/guard closed, safety outputs active.
- **“Power/Fault” LED illuminates red:** Door/guard open, safety outputs off.
- **“Power/Fault” LED flashes red:** Unit failure. See Diagnostic section on page 3.
- **“Power/Fault” LED flashes green:** Safety inputs off.

Mounting Information

Use non-removable screws, bolts, or nuts to mount the switch and actuator. Do not over torque the mounting hardware.

Position the switch and actuator so they are aligned with each other.

Mount the switch and actuator to removable guard, door, or gate. Keep the switch and actuator within the sensing range below.

This switch is not meant to be fully embedded in metal. Use the stainless steel version (440N-Z21S17* or 440N-Z21U17*) for embedding.

Nut Torque Specification

Plastic Barrel Switch: 2.26 N•m (20 in•lb)

Plastic Actuators: 2.26 N•m (20 in•lb)

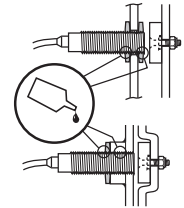

Minimum Distance Between Sensors

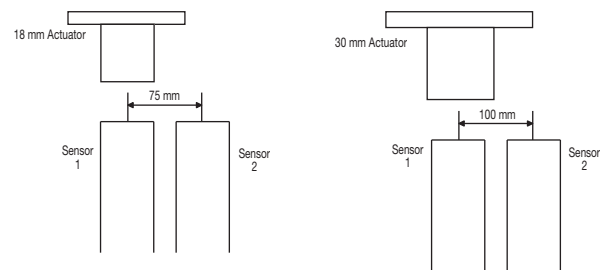

Misalignment Curve

18 mm Unit with 18 mm Target

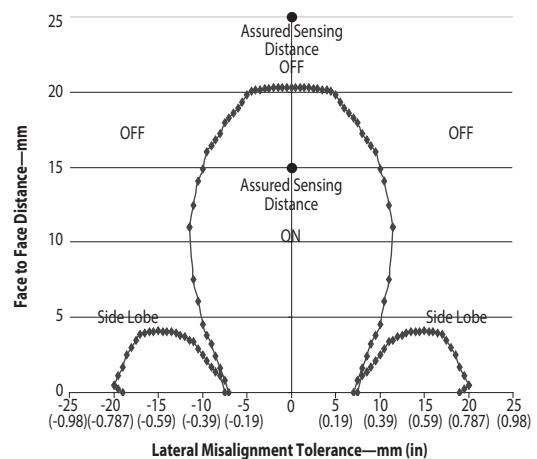

IMPORTANT

There must be a minimum spacing of 4 mm (0.157 in.) if actuator and sensor face approaches laterally. This will prevent false triggering due to the side lobe areas.

18 mm Unit with 30 mm Target

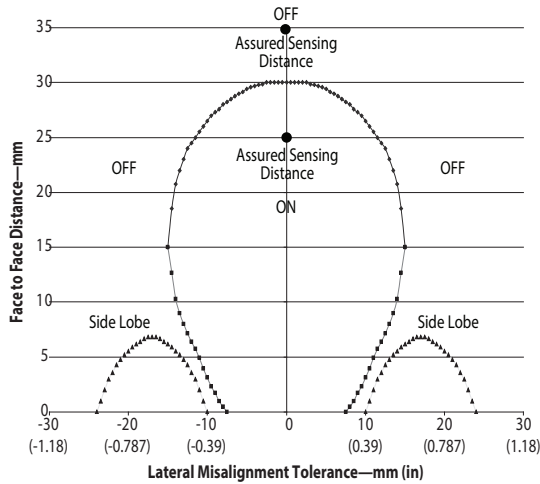

IMPORTANT

There must be a minimum spacing of 7 mm (0.275 in.) if actuator and sensor face approaches laterally. This will prevent false triggering due to the side lobe areas.

Wiring Diagram

8-Pin Unit

Pin Number	Wire Color	Signal
1	White	Aux. Outputs
2	Brown	+24V
3	Green	NA
4	Yellow	OSSD 2, +24V Input
5	Grey	OSSD 1
6	Pink	OSSD 2
7	Blue	0V
8	Red	OSSD 1, +24V Input

Recommended mating cable, 2 m (6.5 ft)—889D-F8AB-2.
Replace the 2 with 5 (5 m) or 10 (10 m) for standard cable lengths.

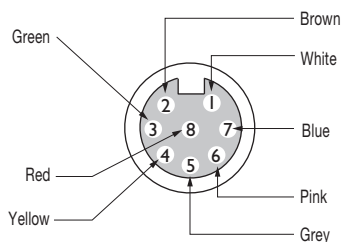

5-Pin Unit

Pin Number	Signal
1	+24V
2	OSSD 1
3	0V
4	OSSD 2
5	Aux.

Recommended cordset, 2m (6.5 ft) - 889D-F5AC-2. Replace the 2 with 5 (5 m) or 10 (10 m) for standard cable lengths.

Note: If the user does not require the auxiliary signal, a 4-pin cordset (889D-F4AC-2) can be used.

Recommended patchcord for use with ArmorBlock® Guard Safety I/O, 2 m (6.5 ft) - 889D-F4ACDM-2. Replace the 2 with 0M3 (0.3 m), 1 (1 m), 5 (5 m), or 10 (10 m) for standard cable lengths.

Note: Do not use a 5-pin patchcord with the ArmorBlock.

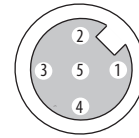

Diagnostic

Unit Indicators (per IEC 60073)

	State	Status	Troubleshooting
Device Output LED	Off	Not Powered	NA
	Red	Not Safe, OSSD not active	NA
	Green	Safe, OSSD active	NA
	Green Flash	Power up test or OSSD inputs not valid	Check 24V DC or OSSD inputs (yellow and red wire)
	Red Flash	1 Hz Flash Recoverable Fault 4 Hz Flash Non-recoverable Fault	Recoverable fault — check OSSD outputs are not shorted to GND, 24V DC or each other. Cycle power.

IMPORTANT

Refer to Technical Specifications (page 1) for certification information and ratings.

Troubleshooting

Series Circuit

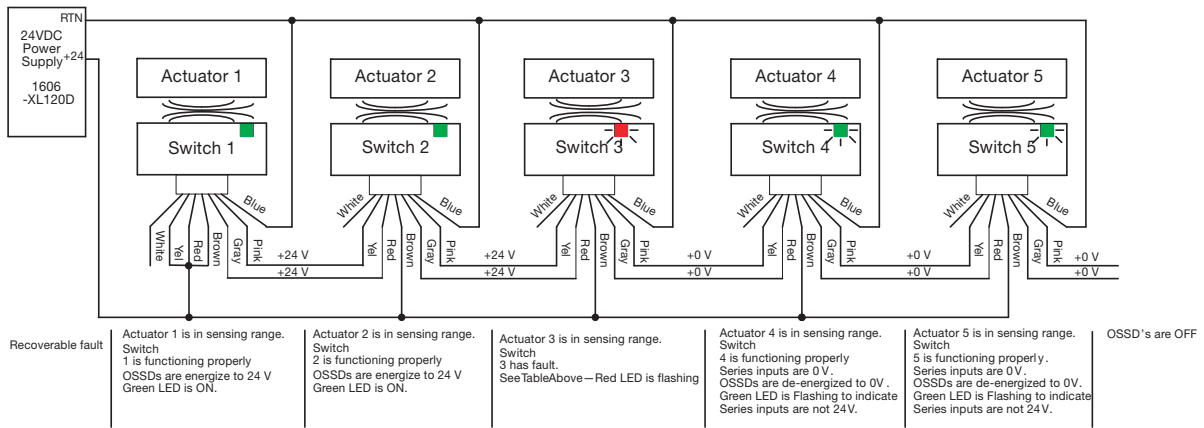

IMPORTANT

Refer to Technical Specifications (page 1) for certification information and ratings.

Unit Response Time (does not include safety control system response time)

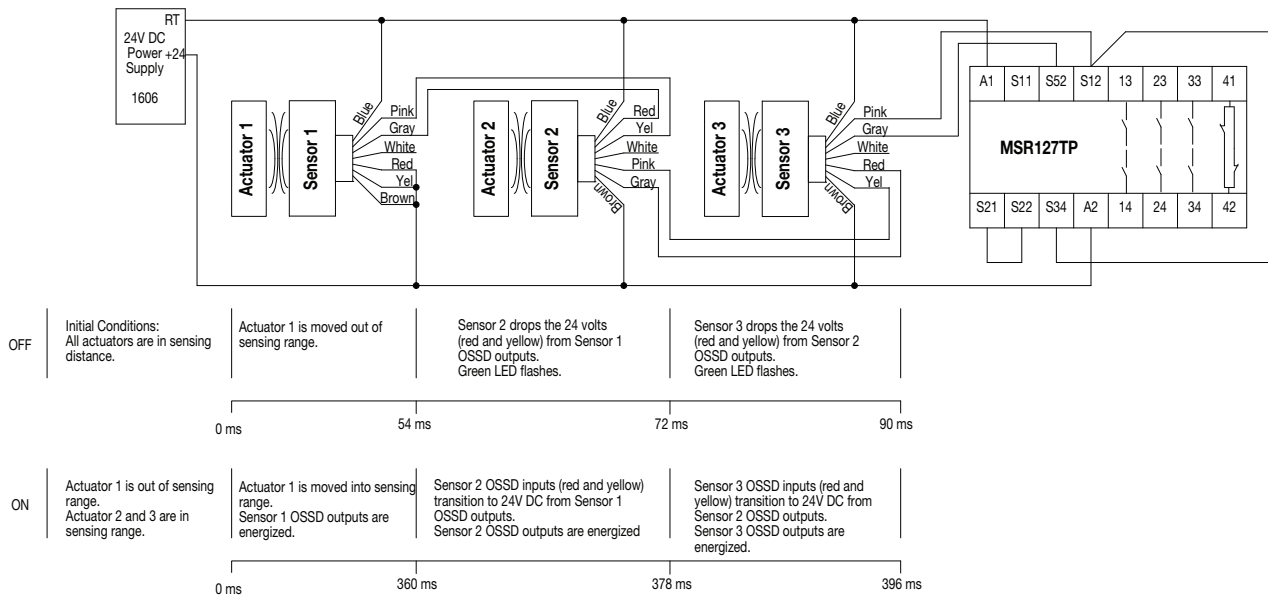

IMPORTANT

Refer to Technical Specifications (page 1) for certification information and ratings.

Application Wiring Examples

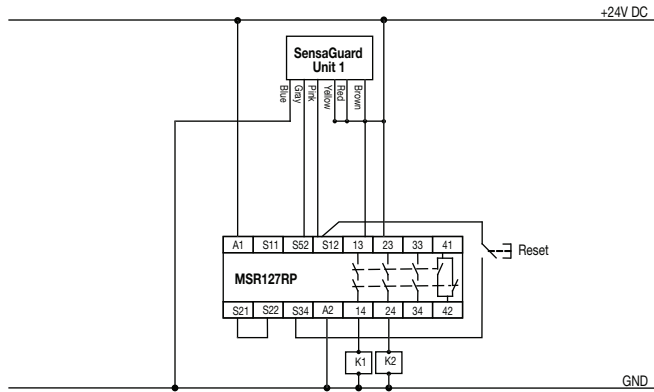

MSR127RP with 1 sensor, monitored manual reset, driving 100S or 700S safety controllers.

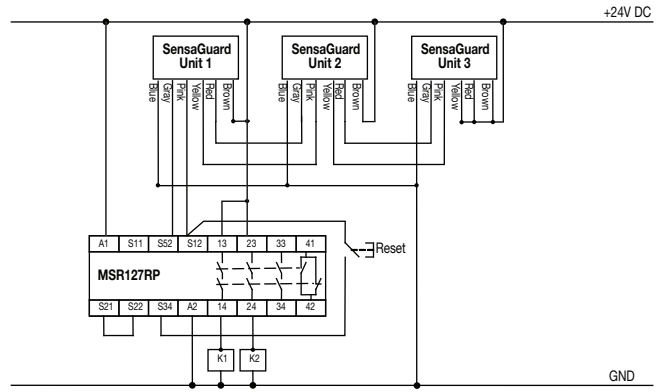

MSR127RP with 3 sensors in series, monitored manual reset, driving 100S or 700S safety controllers

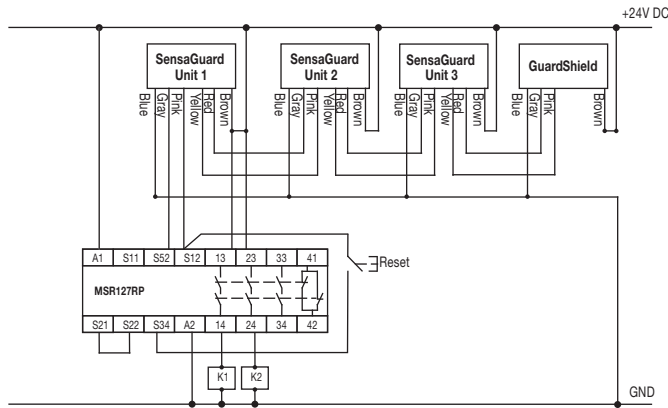

MSR127RP with 3 sensors and 1 440L light curtain in series, monitored manual reset, driving 100S or 700S safety relays.
Note: Light curtain must be last (farthest from MSR127).

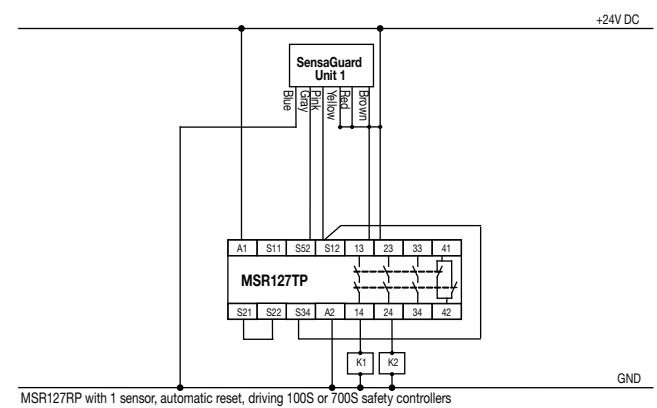

MSR127RP with 1 sensor, automatic reset, driving 100S or 700S safety controllers

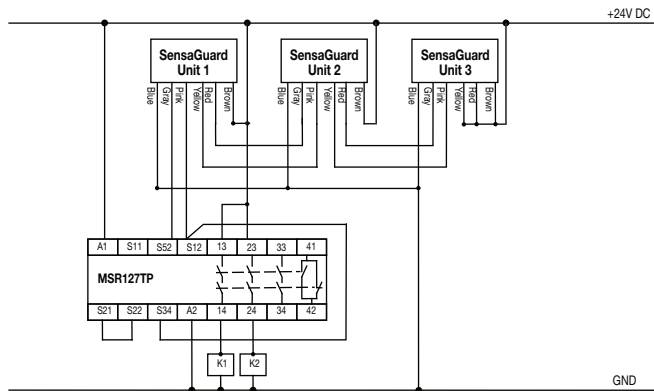

MSR127TP with 3 sensors in series, automatic reset, driving 100S or 700S relays.

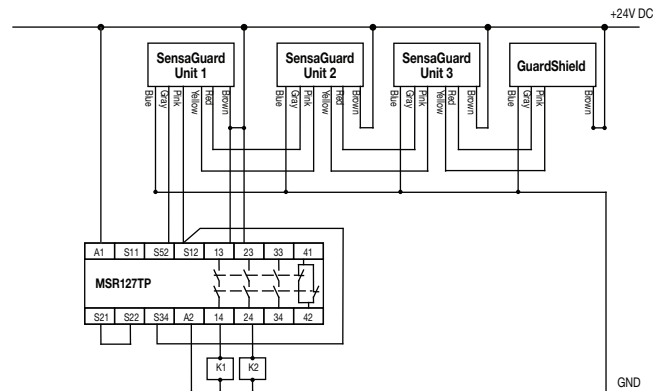

MSR127TP with 3 sensors and 1 440L light curtain in series, automatic reset, driving 100S or 700S safety contactors.
Note: Light curtain must be last (farthest from MSR127)

IMPORTANT

Refer to Technical Specifications (page 1) for certification information and ratings.

List of Recommended Safety Control Interfaces

GSR DI, GSR DIS, GSR SI, CR30, MSR126, MSR127, MSR131, MSR138, MSR211, MSR221, MSR121, MSR320, SmartGuard™, 1791DS/ES CompactBlock™ Guard Safety I/O, 1732DS/ES ArmorBlock Guard Safety I/O. Relay must have OSSD (light curtain) inputs.

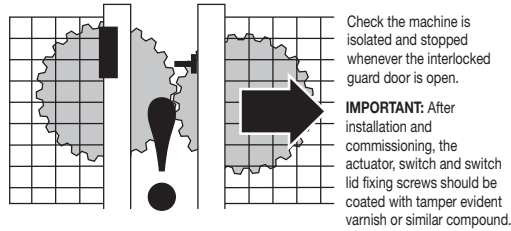

Maintenance

Monthly

Check the correct operation of the switching circuit. Also check for signs of abuse or tampering. Inspect the switch casing for damage.

Repair

If there is any malfunction or damage, no attempts at repair should be made. The unit should be replaced before machine operation is allowed.

Declaration of Conformity

This is to declare that the products shown in this document conform with the Essential Health and Safety Requirements (EHSRs) of the European Machinery Directive. These products also conform to EN 60947-5-3, EN ISO 14119, and have Third Party Approval.

For a comprehensive certificate please visit: www.ab.com/safety.

Allen-Bradley, ArmorBlock, CompactBlock, Rockwell Software, SensaGuard, and SmartGuard are trademarks of Rockwell Automation, Inc.

Trademarks not belonging to Rockwell Automation are property of their respective companies.

Rockwell Automation maintains current product environmental information on its website at

<http://www.rockwellautomation.com/rockwellautomation/about-us/sustainability-ethics/product-environmental-compliance.page>

www.rockwellautomation.com

Power, Control and Information Solutions Headquarters

Americas: Rockwell Automation, 1201 South Second Street, Milwaukee, WI 53204-2496 USA, Tel: (1) 414.382.2000, Fax: (1) 414.382.4444

Europe/Middle East/Africa: Rockwell Automation NV, Pegasus Park, De Kleetlaan 12a, 1831 Diegem, Belgium, Tel: (32) 2 663 0600, Fax: (32) 2 663 0640

Asia Pacific: Rockwell Automation, Level 14, Core F, Cyberport 3, 100 Cyberport Road, Hong Kong, Tel: (852) 2887 4788, Fax: (852) 2508 1846

Publication 440N-IN010C-EN-P — September 2014 — 10000979549 Ver 00

Supersedes Publication 440N-IN010B-EN-P — August 2014

PN-243703

Copyright © 2014 Rockwell Automation, Inc. All rights reserved. Printed in the U.S.A.