

**Vibro level indicator**  
Level limit switches for bulk goods

**VF10**

**Appliance information**

**Rhombus vibration rod**  
robust single rod - compact and versatile

Index	Page
Application   Construction   Characteristics   Function .....	02
Technical data   Electrical data .....	02
Versions / Dimensions .....	03
Dimensions - separate rectangular-housing   Electrical connection .....	04
Electrical data C5i   Electrical connection C5i .....	04
High alarm sensor   Low alarm sensor .....	05
Possibilities for installation   Protection against heavy load .....	06
Maximum load for vibration rod   Protection against bulk solids crashing down upon the rod ..	06
Supply and evaluation device VF-VEC8-B22 .....	07

**MOLLET** accurate point level

ATEX option

B1 **Dust**  II 1/2D Ex ta/tb IIIC T95 °C Da/Db

ATEX option

B3 **Dust**  II 1/3D Ex ta/tc IIIC T95 °C Da/Dc

ATEX option

B11 **Gas+**  II 1/2G Ex ia IIB T4 Ga  
**Dust**  II 1/2D Ex ia IIIC TX Da

## Application (intended use)

The **MOLOSvibro** of the **VF10** series is intended for the use as **level limit switch** in **silos and vessels**.

For all bulk solids with a minimum density of **0.01 t/m<sup>3</sup>**.

For application in **all industry sectors**.

## Bauweise

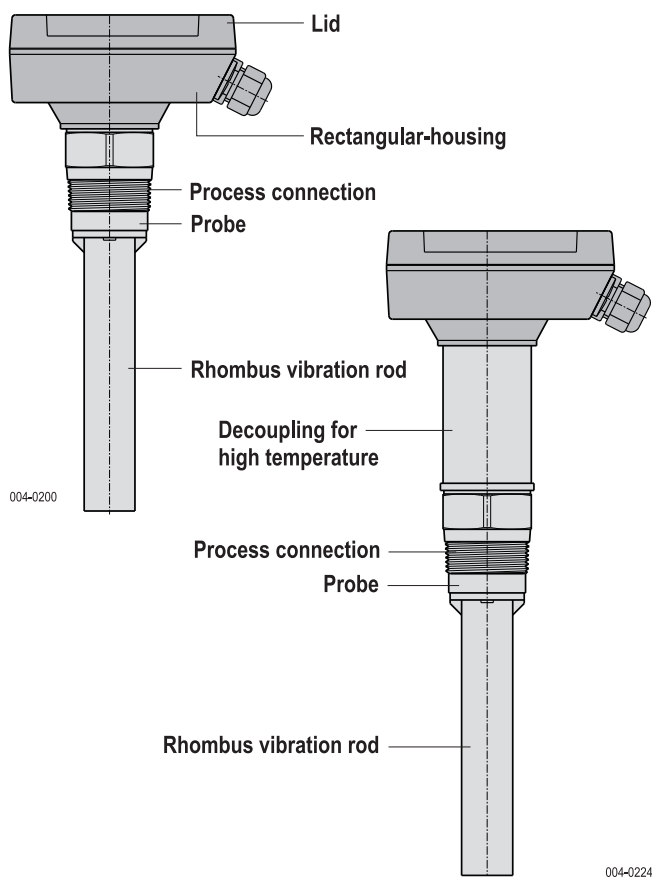

## Characteristics

- Very robust vibration rod in Rhombus shape
- High sensitivity for bulk solids with a minimum density of 10 g/l
- Interface measurement possible
- Patented, braced membrane
- No digging free within the bulk solids due to small vibration amplitude
- Adjustable sensitivity in three setting adjustments:  
A for light, B for normal and C for sticking bulk solids
- High level and low level alarm selectable

## Function

- Oscillation of the Rhombus vibration rod with a resonance frequency of approx. 285 Hz is stimulated by the electronic.
- As soon as the vibration rod has been covered by bulk solids, the oscillation will be damped.
- The electronic detects the damping and switches the relay signal.
- If the filling level sinks below the vibration rod, the rod starts vibrating with its resonance frequency again and the relay switches back.

## Technical data

<b>Material</b>	Rectangular-housing Process connection and probe Rhombus vibration rod Suspension cable sheath	Aluminium, RAL7001 Stainless steel 1.4301 / 304 Stainless steel 1.4301 / 304 Polyurethane
<b>Process connection</b>	<b>R3</b>	R1½ EN 10226 or N3 1½" NPT
<b>Ambient temperature</b>	with separate housing	-40 °C ... +70 °C -40 °C ... +80 °C
<b>Process temperature</b>	<b>VF12, VF13</b> <b>VF15</b>	-40 °C ... +80 °C -40 °C ... +70 °C
<b>VF12, VF13 high temperature</b>	<b>E1</b> <b>E2</b> <b>E3</b>	-40 °C ... +150 °C -40 °C ... +200 °C -40 °C ... +250 °C
<b>Process pressure</b>		-0.95 bar ... 10 bar
<b>Minimum density of bulk solids</b>		0.01 kg/l (t/m <sup>3</sup> )
<b>Response delay</b>	for damping for start oscillation	1 second 2 to 5 seconds
<b>Cable entry</b>		Gland 2xM20x1,5
<b>Type of protection</b>	with separate rectangular-housing	<b>IP66/IP67</b> acc. DIN EN 60529 <b>IP65</b> acc. DIN EN 60529
<b>Maintenance</b>		none
<b>Maximum load for the end of the vibration rod</b>		1000 N vertical (V) 250 N horizontal (H)
<b>Maximum tensile force at suspension cable of type VF15</b>		2000 N
<b>Installation position</b>	<b>VF12, VF13</b> <b>VF15</b>	any vertical

## Electrical data

<b>Supply voltage</b>	<b>C8</b>	20 ... 250 V AC / DC	<b>Supply</b>
<b>Power consumption</b>		≤ 3 VA / 3 W	
<b>Signal relay</b>		two potential free change-over contacts	
<b>Capacity of contact</b>		8 A / 250 V AC 192 / 72 W at 24 / 48 V DC	
<b>Supply voltage</b>	<b>C5</b>	24 V DC ±10%	<b>Supply</b>
<b>Power consumption</b>		≤ 1 W (without load)	
<b>Signal output</b>		potential free NPN / PNP	
<b>Capacity of contact</b>		maximum 20 W switching capacity maximum 350 mA constant current	

**Versions / Dimensions**

**VF12 Compact sensor**

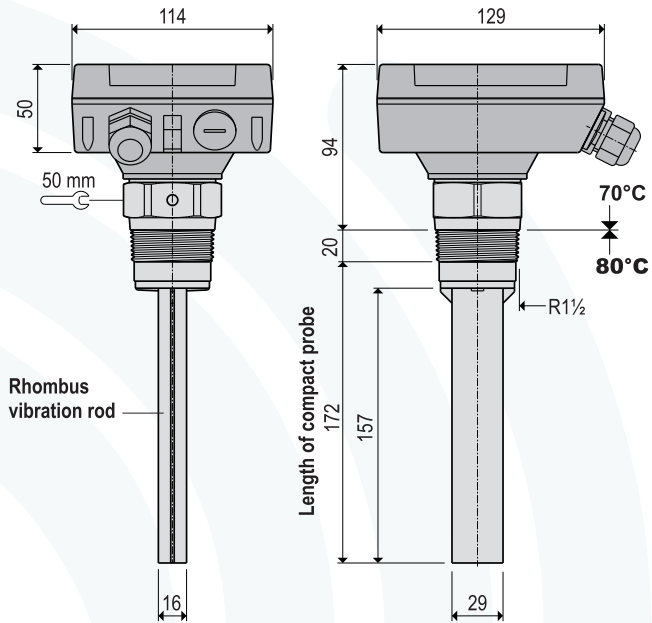

004-0221

**VF15 Suspension cable sensor**

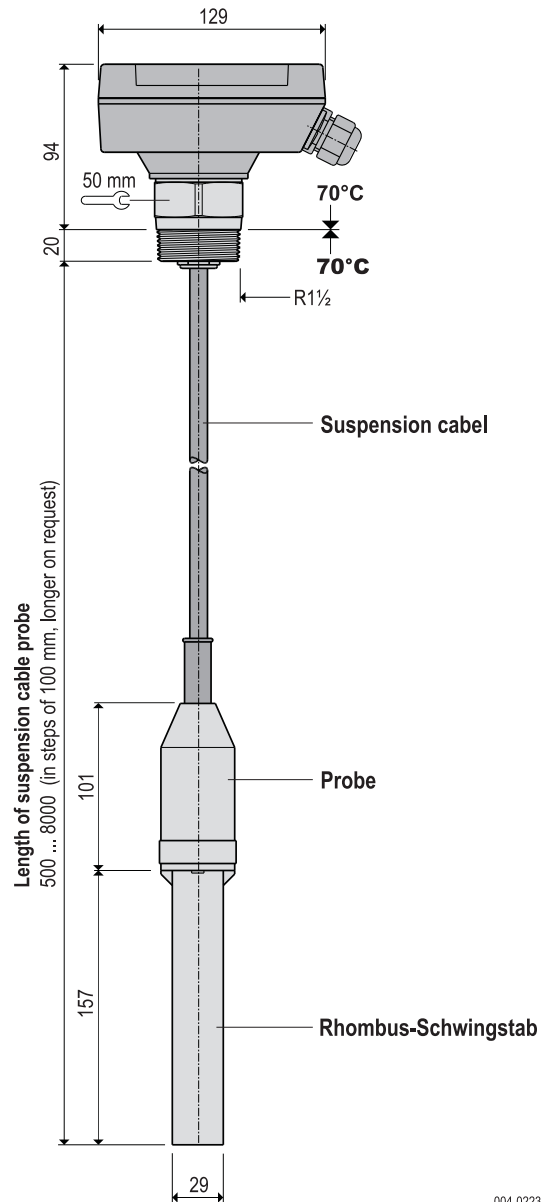

004-0223

**VF13 Rod extension sensor**

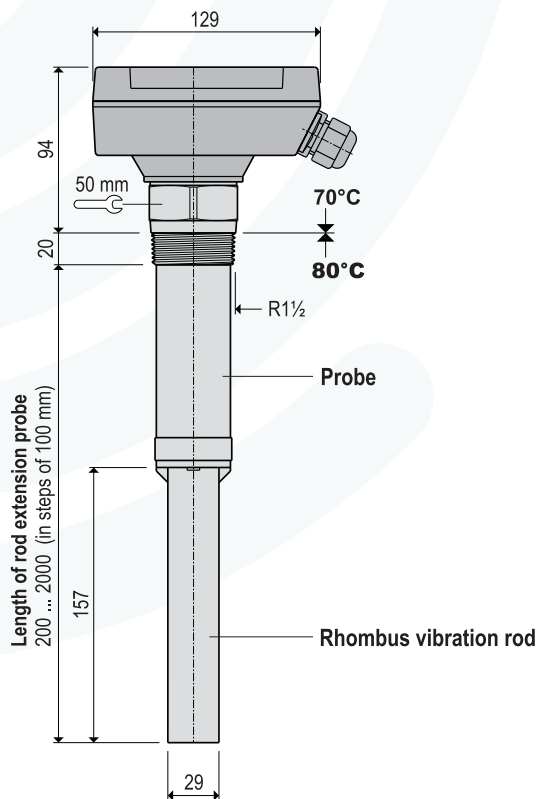

004-0222

**E1 ... E3 High temperature**

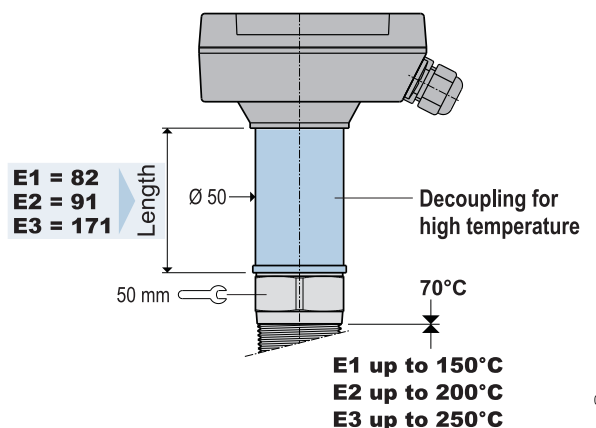

004-0224

**Dimensions**

**A22 Separate rectangular-housing**

Front and side views

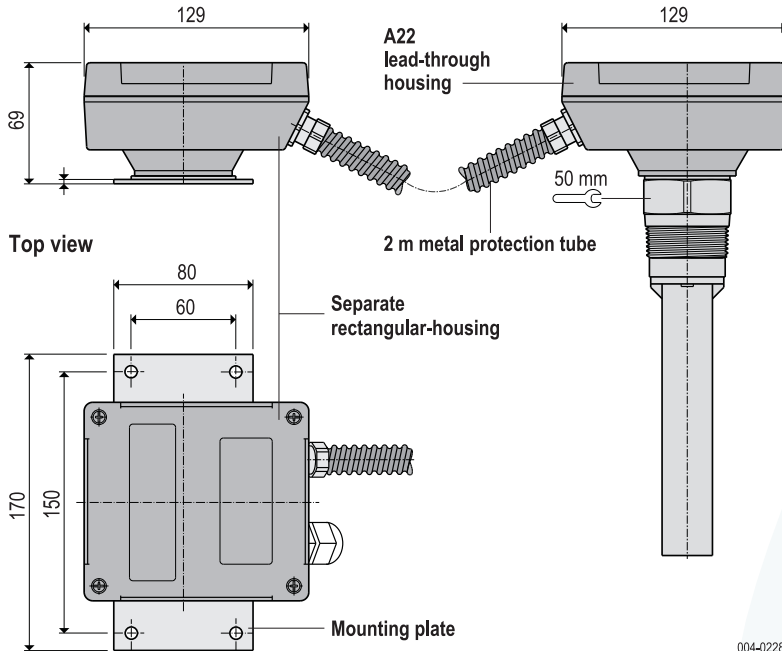

With the separate rectangular-housing the electronic will be mounted remote from the probe.

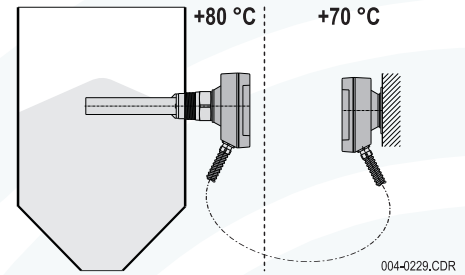

**Application**

- In vessels with heavy vibrations
- Process temperatures of 150 °C to 250 °C only in combination with lead-through housing in high-temperature design
- Ambient temperatures up to +80 °C in close proximity to the container wall.

**Separate rectangular-housing combinable with:**  
**A22** lead-through housing at the probe

Metal protection tube with 2 m length.  
Different length on request.

**Electrical connection**

Wide range electronic C8 (not available with GasEx option B11)

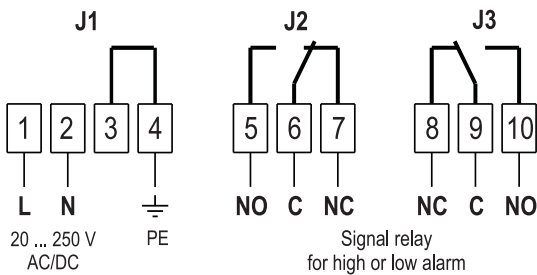

**Electrical connection**

DC voltage electronic C5 (not available with GasEx option B11)

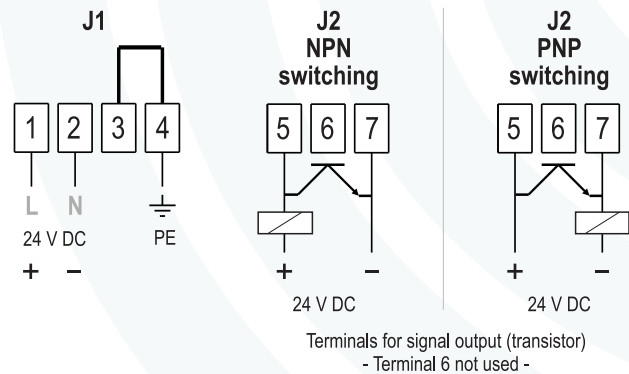

**Electrical data**

<b>Supply voltage</b> $U_i$	23.7 V DC from VF-VEC8-B22
$I_i$	167 mA
$P_i$	958 mW
$L_i$	negligible
$C_i$	negligible

**Electrical connection**

Two wire electronic C5i (only available with GasEx option B11)

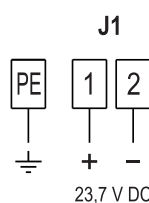

**Supply only with supply and evaluation device VF-VEC8-B22 for GasEx.**

**Current consumption**

<b>High alarm</b> FH	Vibration rod oscillates freely	8 mA
	Vibration rod covered	16 mA
<b>Low alarm</b> FL	Vibration rod covered	8 mA
	Vibration rod oscillates freely	16 mA

### High alarm sensor FH (factory setting)

MOLOSvibro level indicator of the VF10 series are configured for **high level alarm** in the factory setting. The function can be changed with a jumper on the electronic board. The switching status is indicated by a LED on the electronic board, like it is explained below.

**Free status** - vibration rod oscillates freely

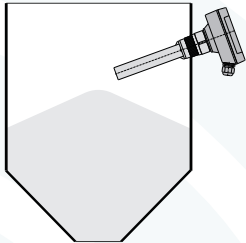

Electronic type

C8

C5

C5i

LED display



LED on

LED on

LED off

Switching status

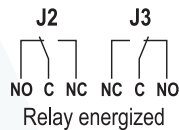

Transistor conductive

8 mA  
Current output

**High alarm** - vibration rod covered with bulk solids

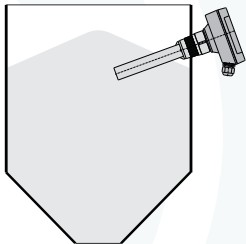

Electronic type

C8

C5

C5i

LED display



LED blinking

LED blinking

LED on

Switching status

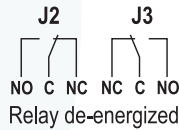

Transistor blocks

16 mA  
Current output

### Low alarm sensor FL (jumper repositioned)

MOLOSvibro level indicator of the VF10 series can be used for **low level alarm** with a changed factory setting. The function can be changed with a jumper on the electronic board. The switching status is indicated by a LED on the electronic board, like it is explained below.

**Covered status** - Vibration rod covered with bulk solids

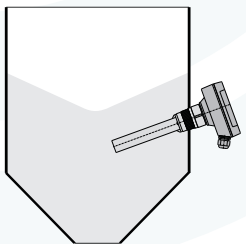

Electronic type

C8

C5

C5i

LED display



LED on

LED on

LED off

Switching status

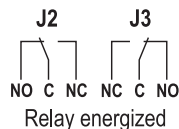

Transistor conductive

8 mA  
Current output

**Leeralarm** - Vibration rod oscillates freely

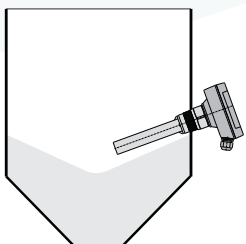

Electronic type

C8

C5

C5i

LED display



LED blinking

LED blinking

LED on

Switching status

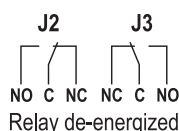

Transistor blocks

16 mA  
Current output

### Possibilities for installation

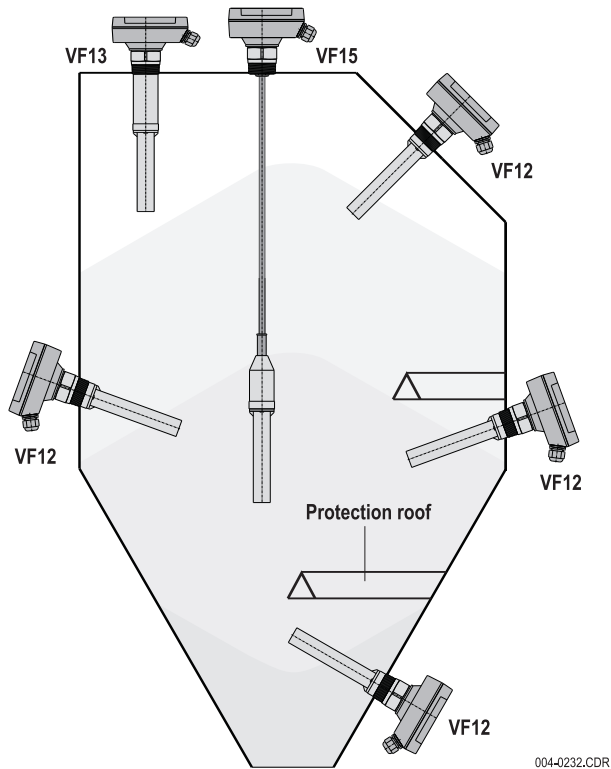

### Protection against heavy load

If needed, a protection roof or a stable deflector has to be installed inside the container, in order to protect the probe and the rod against impinging bulk solids.

Between protection roof and the probe has to be enough space that bulk solids could penetrate but not jam.

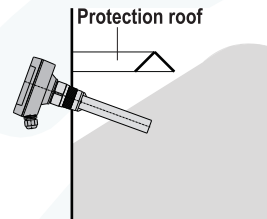

### Maximum load for vibration rod



### Protection against bulk solids crashing down upon the rod

Level indicators must not be affected by flying bulk goods particles e.g. from injection pies, filling pipes or down pipes. Therefore the bulk solids stream should be directed or redirected accordingly, or the level indicator should be placed so that bulk solids cannot impact directly onto the probe and vibration rod.

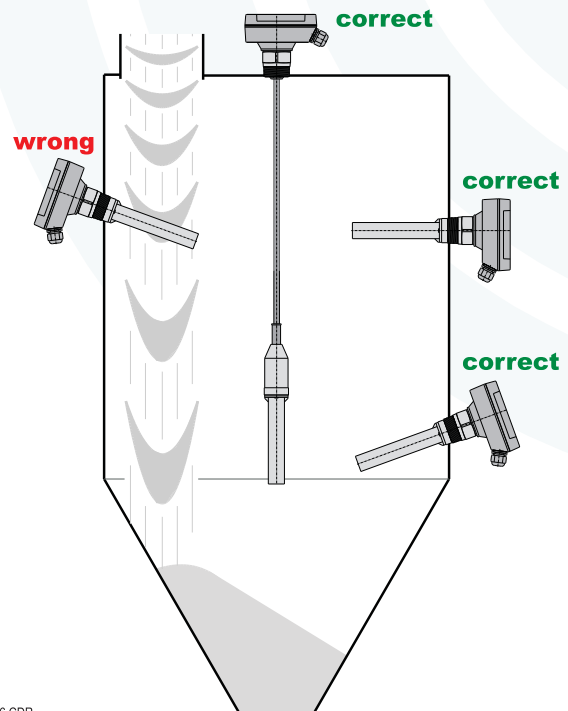
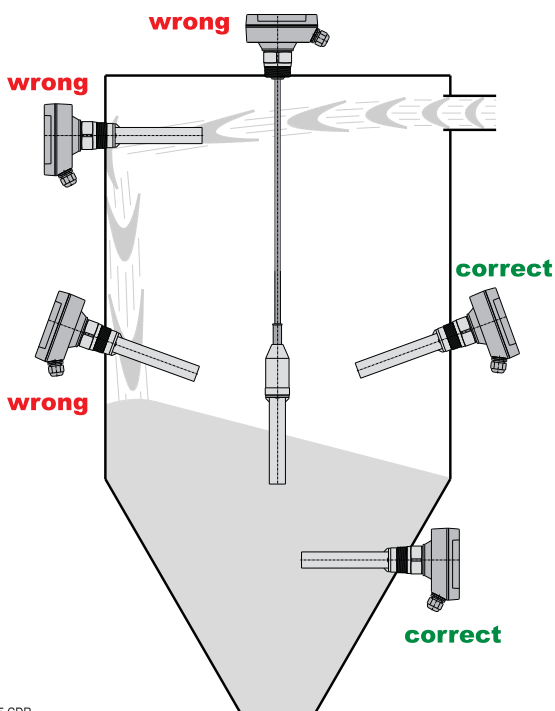

### Application (intended use)

The supply and evaluation device type **VF-VEC8-B22** is intended for the use as power supply for **MOLOSvibro** level indicators that are used in potentially explosive gas atmospheres.

It detects and evaluates the damping of the vibration rod, switches the signal relay and diagnoses a short circuit or broken cable at the connection to the probe and switches the failure relay.

### Dimensions

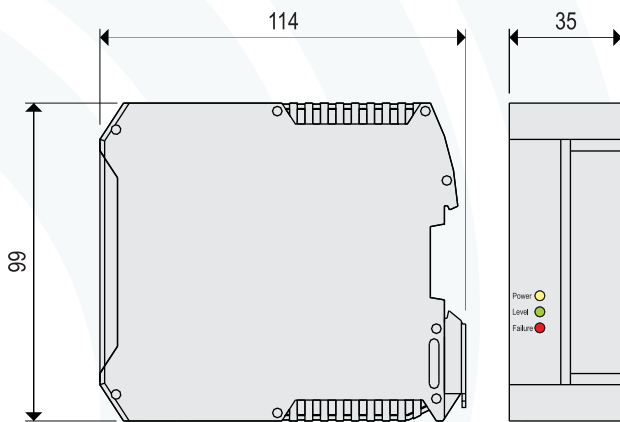

004-0240.CDR

### Technical data

<b>Material</b>	Housing	Polyamid, light gray	
<b>Ambient temperature</b>		-20 °C ... +60 °C	<b>T<sub>a</sub></b>
<b>Supply voltage</b>		20 ... 250 V AC/DC	<b>Supply</b>
<b>Power consumption</b>		≤ 3 VA	
<b>Connection to sensor</b>	<b>Ex i</b>		
	Supply voltage	≤ 23,7 V DC	
	Connection cable light grey	2-wire, maximum 35 Ω per wire	
	Switching threshold	13 mA	
<b>Signal relay (potential free)</b>		change-over contact (SPDT)	
<b>Error relay (potential free)</b>		change-over contact	
<b>Capacity of contact</b>	AC	6 A / 250 V	
	DC	≤ 6 A at 24 V / 0,5 A at 48 V	
	DC	minimum 24 V / 100 mA	
<b>Connection clamps</b>		maximum 2.5 mm <sup>2</sup>	
<b>Type of protection</b>		<b>IP20</b> acc. DIN EN 60529	<b>IP</b>
<b>Ignition protection type</b>		⊕ II (1) G [Ex ia Ga] IIB	
		⊕ II (1) D [Ex ia Da] IIIC	
<b>LED display</b>	Power <b>yellow</b>	Power supply available	
	Level <b>green</b>	Filling level (high / low)	
	Failure <b>red</b>	Error ( short circuit / broken cable )	
<b>Maintenance</b>		none	
<b>Installation</b>		Top hat rail assembly (35 mm)	
<b>Installation position</b>		any	

### High and low alarm sensor

The signal relay of the supply and evaluation device **VF-VEC8-B22** has a separate switching logic, that is demonstrated below. The function can be changed with a jumper on the two wire electronic board **C5i** installed in the **MOLOSvibro** sensor housing.

#### High alarm sensor FH (factory setting)

##### Free status

Vibration rod oscillates freely

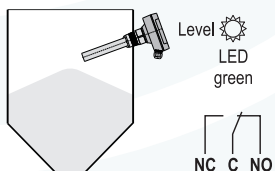

##### High alarm

Vibration rod covered with bulk solids

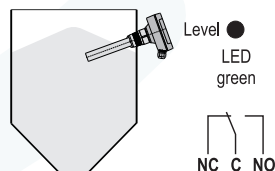

#### Low alarm sensor FL (jumper repositioned)

##### Covered status

Vibration rod covered with bulk solids

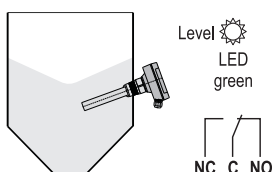

##### Low alarm

Vibration rod oscillates freely

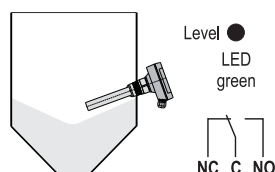

### Electrical connection

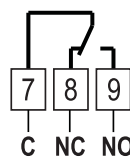

Signal relay for high and low alarm

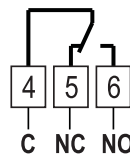

Error relay for short circuit and broken cable  
 OK = Relay energized Connection C-NO  
 Failure = Relay de-energized Connection C-NC

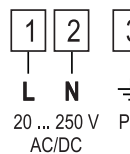

Supply voltage  
 Wide range electronic C8

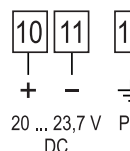

Connection to sensor **MOLOSvibro Typ C5i**  
 Two wire electronic Ex i (intrinsically safe)  
 Blue clamps

Subject to modification

