

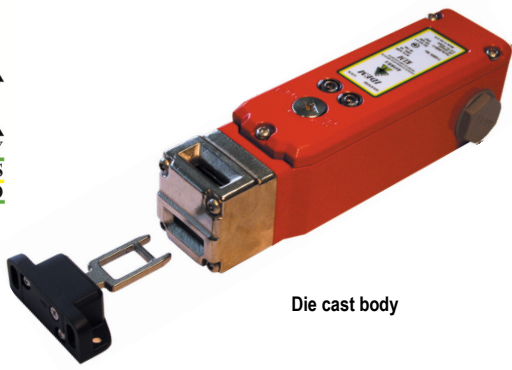

Safety Interlock Switch with Guard Locking

KLM KLM-RR Operating Instructions



Die cast body

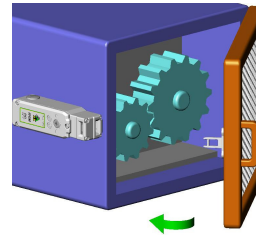

Hinged Guard

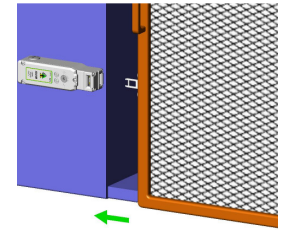

Sliding Guard

IMPORTANT NOTE:

Read and understand these instructions before installing, operating, or maintaining this equipment.

The product is designed to be a component of a customised safety orientated control system. It is the responsibility of the user to ensure the correct overall functionality of its systems and machines. IDEM, its subsidiaries and affiliates, are not in a position to guarantee all of the characteristics of a given system or product not designed by IDEM.

Application and Operation:

Safety Interlock Switches with Guard Locking are designed to fit to the leading edge of sliding or hinged guard doors to provide positively operated switching contacts and provide a tamper resistant key mechanism. They are designed to provide robust position interlock detection and holding closed of moving guards. The switch is rigidly mounted to the frame of the guard or machine. The actuator is fitted to the moving part (frame) of the guard and is aligned to the switch entry aperture. The actuator profile is designed to match a cam mechanism within the switch head and provides a positively operated not easily defeatable interlock switch. When the guard is closed and the actuator is inserted into the switch the safety contacts close, the actuator is locked and the machine start circuit can be enabled. When the solenoid is energised the safety contacts are positively opened, the machine stop circuit is broken and the guard door can be opened.

Installation:

- Installation of all interlock switches must be in accordance with a risk assessment for the individual application. Installation must only be carried out by competent personnel and in accordance with these instructions.
- M5 mounting bolts must be used to fix the switch and actuator, the tightening torque to ensure reliable fixing is 4.0 Nm. **To prevent loosening of the switch after installation, always fix the M5 mounting bolts with a thread-locking compound or secure using self locking nuts.**
Tightening torque for the lid screws, conduit entry plugs and cable glands must be 1.5 Nm to ensure IP seal. Only use the correct size gland for the conduit entry and cable outside diameter.
Tightening torque for the connection terminal screws is 0.7 Nm, max conductor size is 1.0 sq.mm.
The switch head position can be selected by removing the actuator, loosening the 4 head bolts and then rotating the head to the position required. Re-tighten the head bolts and then check actuator insertion and withdrawal. Tightening torque for the head bolts is 1.5Nm.

- Always fit a mechanical stop to the guard to prevent damage to the front of the switch.
Set the actuator gap to 3mm when the guard is closed and against the stop. (See Fig. A.)
Use alignment guides to ensure that the actuator enters the switch without interfering with the sides of the switch aperture.
If fitted, ensure access to at least one of the auxiliary release points.
The switch can be positioned / shielded to prevent unintended actuation of the auxiliary release.
The auxiliary release function is achieved by use of a tool and is to be used in exceptional circumstances.
The auxiliary release can be protected by use of a tamper coating to protect against unintended operation.
If operated this tamper protection must be restored.
Always fit the aperture plug to the unused entry aperture to prevent debris entering the switch mechanism.

- After installation check operation of all control circuits and the locking function. For applications with a run down time after removing power, ensure that the correct timing allowance has elapsed before energising the solenoid.

LED 1 RED will illuminate when power is applied to A1 and A2 (solenoid feed).
LED 2 GREEN (if used) will be illuminated when the actuator is locked.

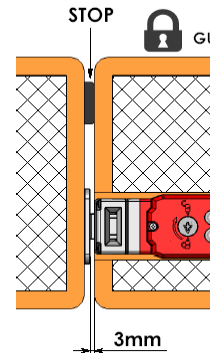
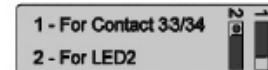

Fig. A

5. IMPORTANT!

At installation choose the status of Terminals 33 and 34 by setting the slide switch inside the switch housing.



If LED2 is used always check for correct .dc polarity.
Terminal 33: 0V.dc Terminal 34: +24V.dc

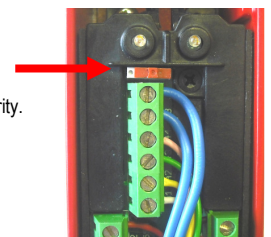
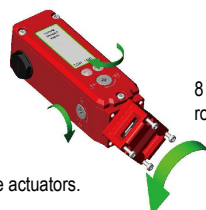

Fig. B

Top or Side
Auxiliary release points (if fitted).



8 actuator entry positions
rotatable head

IMPORTANT

The Risk Assessment for the particular application should include the risk of spare actuators. Spare actuators should not be readily available and must be securely controlled. Application consideration must be given to the fixing of the actuator which has to be in a way that prevents disassembly by easy means. If fitted, it should not be possible to operate the manual escape release from outside of the safeguarded area. Measures should be taken to reduce the risk of improper activation.

Ensure that the switch holding force (Fzh) is sufficient to withstand the static forces applied during normal use and dynamic effects caused by bouncing of the guard shall not create an impact reaction force which exceeds the holding force. If the expected impact reaction forces are higher than the specified holding force for the switch, then design measures must be applied to avoid the force.

The safety functions and mechanics must be tested regularly. For applications where infrequent guard access is foreseeable, the system must have a manual function test to detect a possible accumulation of faults. At least once per month for PLe Cat3/4 or once per year for PLd Cat3 (ISO13849-1). Where possible it is recommended that the control system of the machine demands and monitors these tests, and stops or prevents the machine from starting if the test is not done. (See ISO14119).

Maintenance:

- Every Month: Check the switch actuator and body for signs of mechanical damage and wear. Replace any switch showing damage.
- Every 6 Months: Check for mechanical damage to switch body or actuator. Isolate power and remove cover. Check screw terminal tightness and check for signs of moisture ingress. Never attempt to repair any switch. Replace any switch displaying damage. **These requirements form part of the product warranty.**

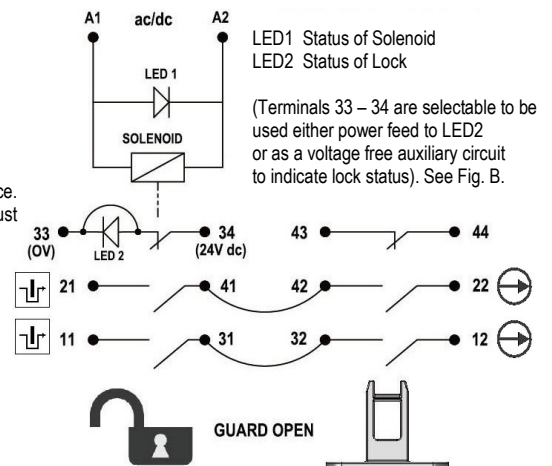

The connections between terminals 31/32 and 41/42 are made using wire links inside the switch (factory fitted). If required by the control circuit, these links are able to be removed at installation to allow individual monitoring of the lock status and actuator status.

Safety Interlock Switch with Guard Locking

24V dc

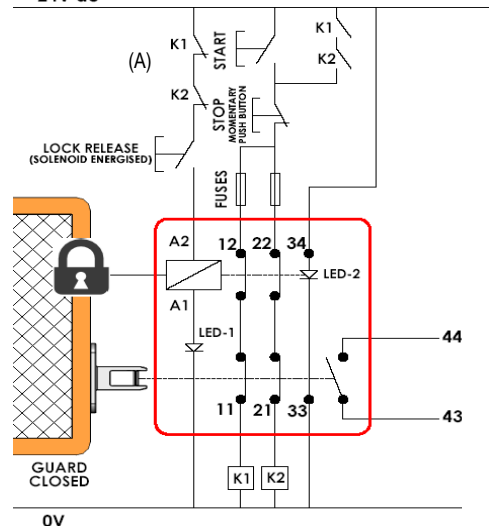

Application Example: Door Interlock with Guard locking - Dual Channel (non-monitored).

The guard is locked closed until the solenoid is energized. The solenoid can only be energized when the auxiliary contacts (A) of contactors K1 and K2 are closed. When the lock release button is pushed the locking mechanism is released and the switch contacts 11-12 and 21-22 are opened. These contacts are in series with contactor coils of K1 and K2 and will prevent re-start whilst the guard is open. If after pressing the Stop button either contactor K1 or K2 stays closed the machine will stop but the solenoid cannot be energized or the guard opened. LED 1 provides visual indication of solenoid power applied. LED 2 provides visual indication of guard locked and machine able to start. System is shown with machine stopped, guard closed and locked, and the solenoid able to be energised (Lock released).

| Quick Connect (QC) M23 12 way Male Plug (Pin view from switch) | Switch Circuit |
|--|----------------|
| 1 3 | A1 A2 |
| 4 6 | 11 / 12 |
| 7 8 | 21 / 22 |
| 2 5 | 43 / 44 |
| 9 | 33 |
| 10 | 34 |
| Earth | 12 |

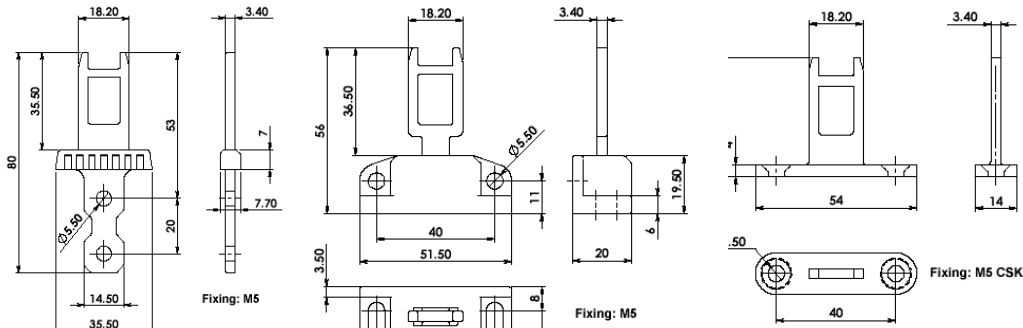

Dimensions (mm)

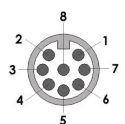
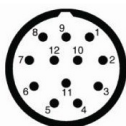

| Quick Connect (QC) M12 8 Way Male (on Flying Lead 250mm) Pin view from switch | Switch Circuit |
|---|----------------|
| 2 7 | A1 A2 |
| 4 6 | 11 / 12 |
| 8 5 | 21 / 22 |
| 3 1 | 43 / 44 |

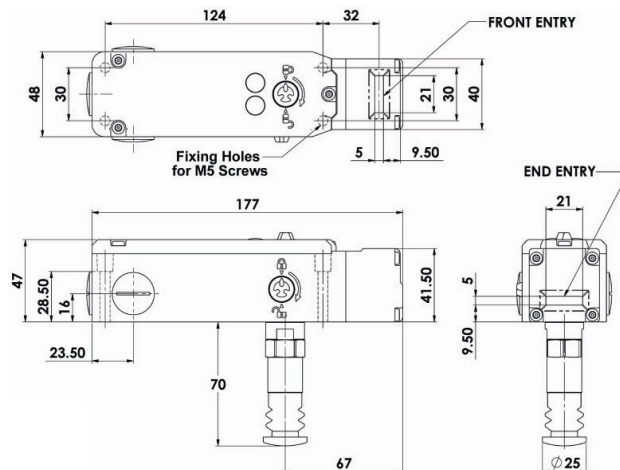

Actuator insertion (mm)

| | 6.0 | 5.0 | 0 mm |
|-------|------|-----|------|
| 11/12 | Open | | |
| 21/22 | Open | | |
| 33/34 | | | Open |
| 43/44 | | | Open |

The NC circuits are closed when the guard is closed and the actuator is present.

All NC contacts are positively operated at withdrawal of actuator

Conforming to Standard:

ISO14119, IEC60947-5-1, UL508, ISO13849-1

Safety Classification and Reliability Data:

Mechanical Reliability B10d
ISO 13849-1
EN 62061
Safety Data - Annual Usage

2.5 x 10⁶ operations at 100mA load up to PLe / Cat.4 depending upon system architecture up to SIL3 depending upon system architecture 8 cycles per hour / 24 hours per day / 365 days MTTFd 356 years

Solenoid Voltage (by part number)
LED 2 Supply Voltage
Safety Contacts 11/12 21/22

24V ac/dc or 110V. ac or 230V. ac +/- 10% (12W.)
24V dc +/- 10%
Utilization Category AC15 A300 3A.
Thermal Current (Ith) 5A

Overload protection fuse (fuse externally)
Auxiliary Contact 33/34 (selectable with LED2)
Auxiliary Contact 43/44

10A. (FF).
24V.ac/dc 0.5A. maximum.
230V.ac/dc 0.5A. maximum.

Rated Insulation Voltage
Rated Impulse Withstand Volt
Travel for Positive Opening

600VAC
2500VAC
10mm

Approach Speed
Man. Actuation Frequency

200mm/m. to 1000mm/s.
2 cycle/sec

Actuator entry minimum radius
Case Material

175mm Standard 100mm Flexible
Die cast metal

Head Material
Actuator Material

Stainless Steel 316
Stainless steel 316

Enclosure Protection
Operating Temperature

IP67
-25°C to 40°C

Holding Force
Vibration

F1Max: 3000N. Fzh: 2307N.
IEC 68-2-6, 10-55Hz+1Hz,
Excursion: 0.35mm, 1 octave/min

Conduit Entry
Fixing

Various (See Sales Part Numbers)
4 x M5

Information with regard to UL 508: Type 1 enclosure. Maximum temperature 40°C.
Use 16-28AWG stranded copper conductors (rated 90°C).
Terminal Torque 6 lb ins. (0.7Nm).
Intended for same polarity use. A300 Pilot Duty. 240V. 3A. PF 0.38 or greater, tested for 6,000 cycles endurance
Use one polymeric conduit connection. Not suitable for connection to rigid metal conduit.
(Earth bonding terminal inside enclosure if required).



WARNING: DO NOT DEFEAT, TAMPER, OR BYPASS THE SAFETY FUNCTION. FAILURE TO DO SO CAN RESULT IN DEATH OR SERIOUS INJURY.

AVERTISSEMENT: NE PAS DESACTIVER, MODIFIER, RETIRER, OU CONTOURNER CETI INTERVERROUILLAGE IL PEUT EN RESULTER DES BLESSURES GRAVES DU PERSONNEL UTILISATEUR.

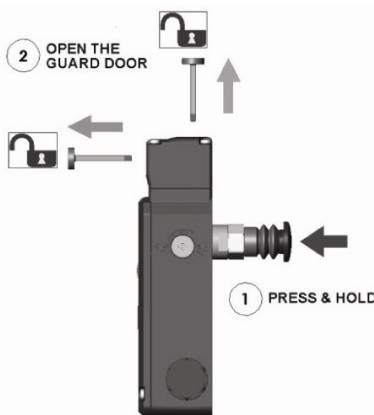

KLM-RR Rear Escape Release version

Where the Risk Assessment for the application permits, a non latching escape release version (KLM-RR) enables quick release of the switch lock in case of emergency. The switch can be mounted such that access to the release button is available from inside the active guard area. Pressing and holding the release button will release the lock mechanism and open the lock monitoring contacts, whilst the guard can be pushed open. Measures should be taken to reduce the risk of improper activation.

Original Instructions.

To request this data sheet in other languages please contact info@idemsafety.com
Um dieses Datenblatt in Deutscher Sprache wenden Sie sich bitte anfordern info@idemsafety.com
Pour obtenir cette fiche en Français, veuillez contacter info@idemsafety.com
Para solicitar esta hoja de datos en Español, por favor contacto con info@idemsafety.com